

# Brief Operating Instructions

## Cerabar PMP43

Pressure measurement  
4-20mA analog



These Instructions are Brief Operating Instructions; they are not a substitute for the Operating Instructions pertaining to the device.

Detailed information about the device can be found in the Operating Instructions and the other documentation:

Available for all device versions via:

- Internet: [www.endress.com/deviceviewer](http://www.endress.com/deviceviewer)
- Smart phone/tablet: *Endress+Hauser Operations App*

# 1 About this document

## 1.1 Document function

The Brief Operating Instructions contain all the essential information from incoming acceptance to initial commissioning.

## 1.2 Symbols

### 1.2.1 Safety symbols

#### DANGER

This symbol alerts you to a dangerous situation. Failure to avoid this situation will result in serious or fatal injury.

#### WARNING

This symbol alerts you to a potentially dangerous situation. Failure to avoid this situation can result in serious or fatal injury.

#### CAUTION

This symbol alerts you to a potentially dangerous situation. Failure to avoid this situation can result in minor or medium injury.

#### NOTICE

This symbol alerts you to a potentially harmful situation. Failure to avoid this situation can result in damage to the product or something in its vicinity.

### 1.2.2 Communication-specific symbols

#### Bluetooth®:

Wireless data transmission between devices over a short distance.

### 1.2.3 Symbols for certain types of Information

#### Permitted:

Procedures, processes or actions that are permitted.

#### Forbidden:

Procedures, processes or actions that are forbidden.

**Additional information:** 

**Reference to documentation:** 

**Reference to page:** 

**Series of steps:** [1.](#), [2.](#), [3.](#)

**Result of an individual step:** L 

1.2.4 Symbols in graphics

**Item numbers:** 1, 2, 3 ...

**Series of steps:** [1.](#), [2.](#), [3.](#)

**Views:** A, B, C, ...

## 1.3 List of abbreviations

**PN**

Nominal pressure

**DTM**

Device Type Manager

**PLC**

Programmable logic controller (PLC)

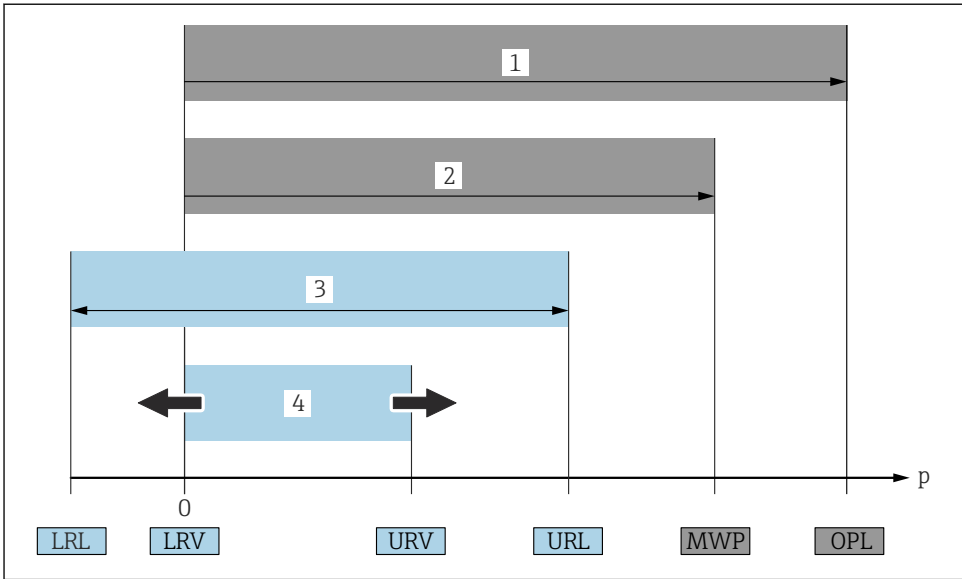

A0029505

- 1 OPL: The OPL (overpressure limit = measuring cell overload limit) for the device depends on the lowest-rated element, with regard to pressure, of the selected components, i.e. the process connection must be taken into consideration in addition to the measuring cell. Pay attention to the pressure-temperature dependency. The OPL may only be applied for a short period of time.
- 2 MWP: The MWP (maximum working pressure) for the measuring cells depends on the lowest-rated element, with regard to pressure, of the selected components, i.e. the process connection also has to be taken into consideration besides the measuring cell. Pay attention to the pressure-temperature dependency. The maximum working pressure may be applied at the device for an unlimited period of time. The maximum working pressure can be found on the nameplate.
- 3 The maximum measuring range corresponds to the span between the LRL and URL. This measuring range is equivalent to the maximum span that can be calibrated/adjusted.
- 4 The calibrated/adjusted span corresponds to the span between the LRV and URV. Factory setting: 0 to URL. Other calibrated spans can be ordered as customized spans.

p Pressure

LRL Lower range limit

URL Upper range limit

LRV Lower range value

URV Upper range value

TD Turn down Example - see the following section.

## 1.4 Turn down calculation

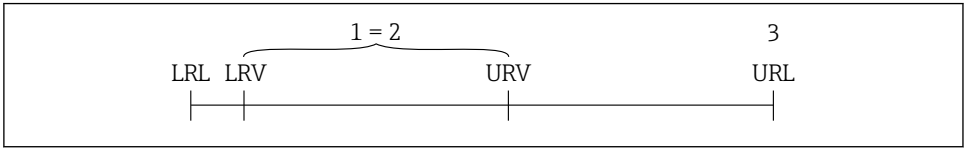

A0029545

- 1 Calibrated/adjusted span
- 2 Zero point-based span
- 3 Upper range limit

Example:

- Measuring cell: 10 bar (150 psi)
- Upper range limit (URL) = 10 bar (150 psi)
- Calibrated/adjusted span: 0 to 5 bar (0 to 75 psi)
- Lower range value (LRV) = 0 bar (0 psi)
- Upper range value (URV) = 5 bar (75 psi)

$$TD = \frac{URL}{|URV - LRV|}$$

In this example, the TD is therefore 2:1. This measuring span is based on the zero point.

## 1.5 Documentation



For an overview of the scope of the associated Technical Documentation, refer to the following:

- *Device Viewer* ([www.endress.com/deviceviewer](http://www.endress.com/deviceviewer)): Enter the serial number from the nameplate
- *Endress+Hauser Operations app*: Enter serial number from nameplate or scan matrix code on nameplate.

## 1.6 Registered trademarks

### Apple®

Apple, the Apple logo, iPhone, and iPod touch are trademarks of Apple Inc., registered in the U.S. and other countries. App Store is a service mark of Apple Inc.

### Android®

Android, Google Play and the Google Play logo are trademarks of Google Inc.

### Bluetooth®

The *Bluetooth*® word mark and logos are registered trademarks owned by the Bluetooth SIG, Inc. and any use of such marks by Endress+Hauser is under license. Other trademarks and trade names are those of their respective owners.

## 2 Basic safety instructions

### 2.1 Requirements for the personnel

The personnel must fulfill the following requirements for its tasks:

- ▶ Trained, qualified specialists must have a relevant qualification for this specific function and task.
- ▶ Are authorized by the plant owner/operator.
- ▶ Are familiar with federal/national regulations.
- ▶ Before starting work, read and understand the instructions in the manual and supplementary documentation as well as the certificates (depending on the application).
- ▶ Follow instructions and comply with basic conditions.

### 2.2 Intended use

The Cerabar is a pressure transmitter for measuring level and pressure.

#### **Incorrect use**

The manufacturer is not liable for harm caused by improper or unintended use.

Avoid mechanical damage:

- ▶ Do not touch or clean device surfaces with pointed or hard objects.

Clarification for borderline cases:

- ▶ For special fluids and fluids for cleaning: Endress+Hauser is glad to provide assistance in verifying the corrosion resistance of fluid-wetted materials, but does not accept any warranty or liability.

#### **Residual risks**

During operation, the housing can heat up to 80 °C (176 °F) due to heat transfer from the process and power loss in the electronics. When in operation, the sensor can reach a temperature close to the medium temperature.

Danger of burns from contact with surfaces!

- ▶ In the event of elevated fluid temperatures, ensure protection against contact to prevent burns.

### 2.3 Occupational safety

When working on and with the device:

- ▶ Wear the required personal protective equipment as per national regulations.
- ▶ Switch off the supply voltage before connecting the device.

### 2.4 Operational safety

Risk of injury!

- ▶ Operate the device only if it is in proper technical condition, free from errors and faults.
- ▶ The operator is responsible for trouble-free operation of the device.

## Modifications to the device

Unauthorized modifications to the device are not permitted and can lead to unforeseeable dangers:

- ▶ If modifications are nevertheless required, consult with the manufacturer.

## Repair

To ensure continued operational safety and reliability:

- ▶ Only use original accessories.

## Hazardous area

To eliminate the risk of danger to persons or the facility when the device is used in the approval-related area (e.g. explosion protection, pressure equipment safety):

- ▶ Check the nameplate to verify if the device ordered can be put to its intended use in the hazardous area.
- ▶ Comply with the instructions in the separate supplementary documentation, which is an integral part of this manual.

## 2.5 Product security

This state-of-the-art device is designed and tested in accordance with good engineering practice to meet operational safety standards. It left the factory in a condition in which it is safe to operate.

The device fulfills general safety requirements and legal requirements. It also complies with the EU directives listed in the device-specific EU declaration of conformity. Endress+Hauser confirms this fact by affixing the CE mark to the device.

## 2.6 IT security

Our warranty is valid only if the product is installed and used as described in the Operating Instructions. The product is equipped with security mechanisms to protect it against any inadvertent changes to the settings.

IT security measures, which provide additional protection for the product and associated data transfer, must be implemented by the operators themselves in line with their security standards.

## 2.7 Device-specific IT security

The device offers specific functions to support protective measures by the operator. These functions can be configured by the user and guarantee greater in-operation safety if used correctly. The user role can be changed with an access code (applies to operation via the onsite display, Bluetooth or FieldCare, DeviceCare, asset management tools e.g. AMS, PDM).

### 2.7.1 Access via Bluetooth® wireless technology

Secure signal transmission via Bluetooth® wireless technology uses an encryption method tested by the Fraunhofer Institute.

- Without the SmartBlue app, the device is not visible via Bluetooth® wireless technology.
- Only one point-to-point connection is established between the device and a smartphone or tablet.
- The Bluetooth® wireless technology interface can be disabled via local operation or via SmartBlue/FieldCare/DeviceCare.

## 3 Product description

### 3.1 Product design

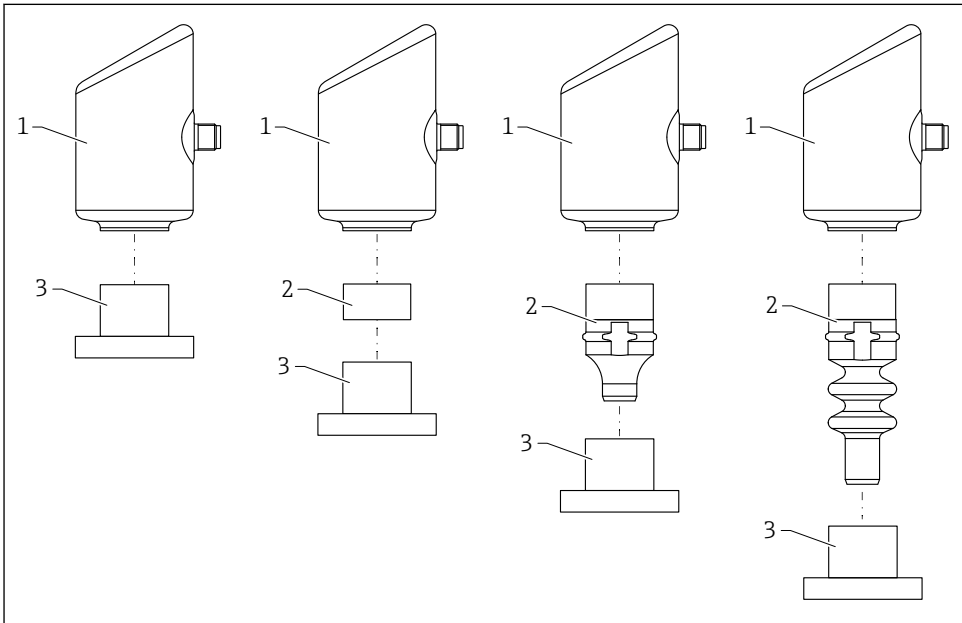

A0055927

- 1 Housing
- 2 Configuration-dependent mounted parts
- 3 Process connection



## 4 Incoming acceptance and product identification

### 4.1 Incoming acceptance

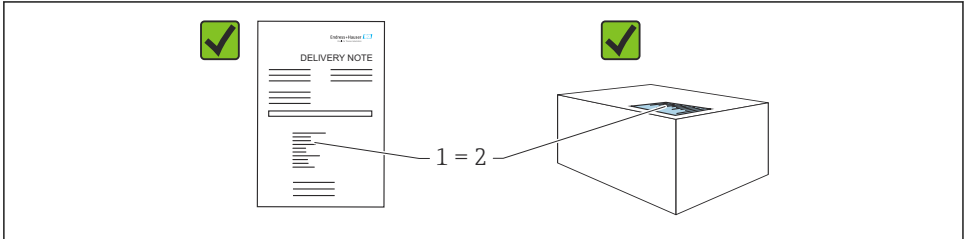

A0016870

Check the following during incoming acceptance:

- Is the order code on the delivery note (1) identical to the order code on the product sticker (2)?
- Are the goods undamaged?
- Do the data on the nameplate correspond to the order specifications and the delivery note?
- Is the documentation provided?
- If required (see nameplate), are the Safety Instructions (XA) provided?



If one of these conditions is not met, please contact the manufacturer's sales office.

### 4.2 Product identification

The following options are available for identification of the device:

- Nameplate specifications
- Order code with breakdown of the device features on the delivery note
- Enter the serial numbers from the nameplates in *Device Viewer* ([www.endress.com/deviceviewer](http://www.endress.com/deviceviewer)): all the information about the device is displayed.

#### 4.2.1 Nameplate

The information that is required by law and is relevant to the device is shown on the nameplate, e.g.:

- Manufacturer identification
- Order number, extended order code, serial number
- Technical data, degree of protection
- Firmware version, hardware version
- Approval-specific information
- DataMatrix code (information about the device)

Compare the data on the nameplate with your order.

## 4.2.2 Manufacturer address

Endress+Hauser SE+Co. KG  
Hauptstraße 1  
79689 Maulburg, Germany

Place of manufacture: See nameplate.

## 4.3 Storage and transport

### 4.3.1 Storage conditions

- Use the original packaging
- Store the device in clean and dry conditions and protect from damage caused by shocks

### Storage temperature

-40 to +85 °C (-40 to +185 °F)

### 4.3.2 Transporting the product to the measuring point

#### WARNING

#### Incorrect transport!

Housing and membrane may become damaged, and there is a risk of injury!

- ▶ Transport the device to the measuring point in the original packaging.

## 5 Mounting procedure

### 5.1 Mounting requirements

#### 5.1.1 Mounting instructions

 During installation, it is important to ensure that the sealing element used has a permanent operating temperature that corresponds to the maximum temperature of the process.

- Devices with CSA approval are intended for indoor use.  
Devices are suitable for use in wet environments in accordance with IEC/EN 61010-1.
- Orient the onsite display using the operating menu to ensure optimum readability.
- The onsite display can be adapted to the light conditions (for color scheme, see  operating menu).
- The devices are mounted according to the same guidelines as manometers.
- Protect housing against impact.

## 5.2 Orientation

### NOTICE

If a heated device is cooled during a cleaning process (e.g. by cold water), a vacuum develops for a short time. Moisture can get into the measuring cell via the pressure compensation filter (1) as a result of the vacuum. Whether or not a filter element is installed depends on the device version.

Device could be destroyed!

► Mount the device as follows.

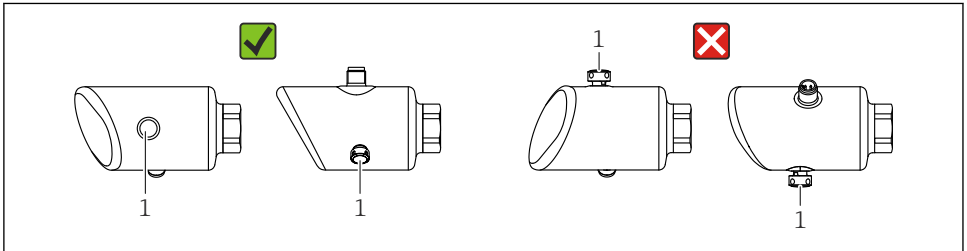

A0054016

- Keep the filter element (1) free from contamination.
- The orientation of the device depends on the measuring application.
- A position-dependent zero point shift (when the vessel is empty the measured value does not display zero) can be corrected

## 5.3 Post-mounting checks

- Is the device undamaged (visual inspection)?
- Are the measuring point identification and labeling correct (visual inspection)?
- Is the device properly secured?
- Is the filter element pointing downwards at an angle or to the side?
- Does the device comply with the measuring point specifications?

For example:

- Process temperature
- Pressure
- Ambient temperature
- Measuring range

## 6 Electrical connection

### 6.1 Connecting the device

#### 6.1.1 Potential equalization

If necessary, establish potential equalization using the process connection or the grounding clamp supplied by the customer.

#### 6.1.2 Supply voltage

12 to 30 V<sub>DC</sub> on a direct current power unit



The power unit must be safety-approved (e.g. PELV, SELV, Class 2) and must comply with the relevant protocol specifications.

For 4 to 20 mA, the same requirements apply as for HART. A galvanically isolated active barrier must be used for devices approved for use in explosion hazardous areas.

Protective circuits against reverse polarity, HF influences and overvoltage peaks are installed.

#### 6.1.3 Power consumption

Non-hazardous area: To meet device safety specifications according to the IEC/EN 61010 standard, the installation must ensure that the maximum current is limited to 500 mA.

#### 6.1.4 Overvoltage protection

The device satisfies the IEC/DIN EN IEC 61326-1 product standard (Table 2 Industrial environment). Depending on the type of port (DC supply, input/output port) different test levels against transient overvoltages (IEC/DIN EN 61000-4-5 Surge) are applied according to IEC/DIN EN 61326-1: Test level on DC power ports and input/output ports is 1 000 V line to earth.

#### Overvoltage protection category

According to IEC/DIN EN 61010-1, the device is intended for use in overvoltage protection category II networks.

#### 6.1.5 Terminal assignment



#### Supply voltage might be connected!

Risk of electric shock and/or explosion

- ▶ Ensure that no supply voltage is applied when connecting.
- ▶ The supply voltage must match the specifications on the nameplate.
- ▶ A suitable circuit breaker should be provided for the device in accordance with IEC/EN 61010.
- ▶ The cables must be adequately insulated, with due consideration given to the supply voltage and the overvoltage category.
- ▶ The connecting cables must offer adequate temperature stability, with due consideration given to the ambient temperature.
- ▶ Protective circuits against reverse polarity, HF influences and overvoltage peaks are installed.

**⚠ WARNING**

**Electrical safety is compromised by an incorrect connection.**

- ▶ Non-hazardous area: To meet device safety specifications according to the IEC/EN 61010 standard, the installation must ensure that the maximum current is limited to 500 mA.

Connect the device in the following order:

1. Check that the supply voltage corresponds to the supply voltage indicated on the nameplate.
2. Connect the device as indicated in the following diagram.
3. Switch on the supply voltage.

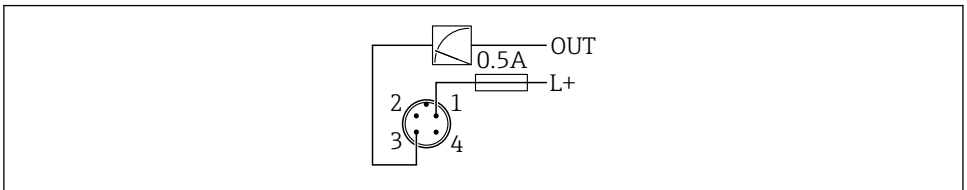
**2-wire**

A0052662

- 1 Supply voltage L+, brown wire (BN)
- 3 OUT (L-), blue wire (BU)

**6.2 Ensuring the degree of protection**

For mounted M12 connecting cable: IP66/68/69, NEMA type 4X/6P

**NOTICE**

**Loss of IP protection class due to incorrect installation!**

- ▶ The degree of protection only applies if the connecting cable used is plugged in and screwed tight.
- ▶ The degree of protection only applies if the connecting cable used is specified according to the intended protection class.

**6.3 Post-connection check**

- Is the device or cable undamaged (visual check)?
- Does the cable used comply with the requirements?
- Is the mounted cable strain-relieved?
- Is the screw connection properly mounted?
- Does the supply voltage match the specifications on the nameplate?
- No reverse polarity, terminal assignment correct?
- If supply voltage is present: is the device ready for operation and does an indication appear on the onsite display or is the green operating status LED lit?

## 7 Operation options

### 7.1 Overview of operation options

- Operation via LED display operating key
- Operation via onsite display
- Operation via Bluetooth®

### 7.2 Access to operating menu via LED display

#### 7.2.1 Overview

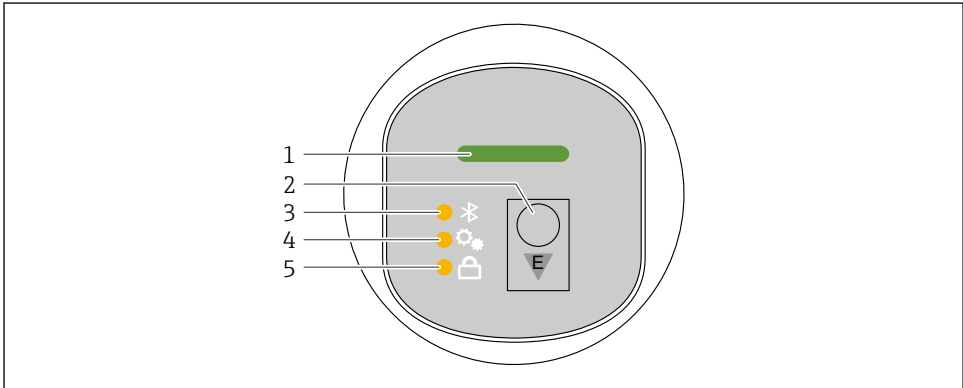

A0052426

- 1 *Operating status LED*
- 2 *Operating key "E"*
- 3 *Bluetooth LED*
- 4 *Position adjustment LED*
- 5 *Keypad lock LED*

 Operation on the LED display is not possible when the Bluetooth connection is active.

#### Operating status LED (1)

See diagnostic events section.

#### Bluetooth LED (3)

- LED lit: Bluetooth enabled
- LED not lit: Bluetooth disabled or Bluetooth option not ordered
- LED flashing: Bluetooth connection established

#### Keypad lock LED (5)

- LED lit: Key locked
- LED not lit: Key released

### 7.2.2 Operation

The device is operated by pressing operating key "E" briefly (< 2 s) or pressing and holding it (> 2 s).

#### Navigation

- The LED for the selected function flashes
- Press the "E" operating key briefly to switch between the functions
- Press and hold down the "E" operating key to select a particular function

*Flashing behavior of LEDs (active/inactive)*

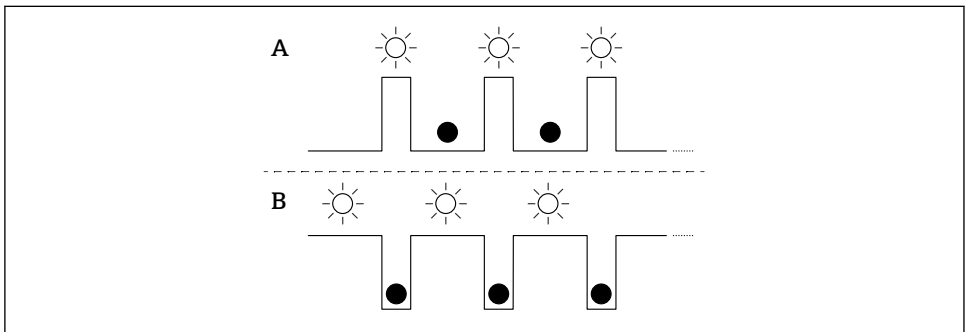

A0053175

A Function selected but not active

B Function selected and active

#### Disabling the keypad lock

1. Press and hold down operating key "E".
  - ↳ Bluetooth LED flashes.
2. Briefly press operating key "E" repeatedly until the keypad lock LED flashes.
3. Press and hold down operating key "E".
  - ↳ Keypad lock is disabled.

#### Enabling or disabling Bluetooth

1. If necessary, disable the keypad lock.
2. Repeatedly press the "E" key briefly until the Bluetooth LED flashes.
3. Press and hold down operating key "E".
  - ↳ Bluetooth is enabled (Bluetooth LED is lit) or Bluetooth is disabled (Bluetooth LED goes out).

## 7.3 Access to operating menu via onsite display

Functions:

- Display measured values, also fault and notice messages
- Display a symbol in the event of an error
- Electronically adjustable onsite display (automatic or manual adjustment of display in 90° increments)
  -  The measured value display rotates automatically depending on the orientation when the device is started. <sup>1)</sup>
- Basic settings via the onsite display with touch control <sup>2)</sup>
  - Locking On/Off
  - Select the operating language
  - Bluetooth On/Off
  - Commissioning wizard for basic settings
  - Read the device information, such as the name, serial number and firmware version
  - Active diagnosis and status
  - Device reset
  - Invert colors for bright lighting conditions

The backlighting is automatically adjusted depending on the terminal voltage.

 The following figure is an example. The display depends on the settings of the onsite display.

Optional display by swiping from left to right (see A, B and C in the following graphic): The swiping motion only works if the display has been ordered with touch control and the display has been unlocked beforehand.

---

1) The measured value display only rotates automatically if automatic alignment is switched on.

2) For devices without touch control, settings can be made using operating tools (FieldCare, DeviceCare, SmartBlue).



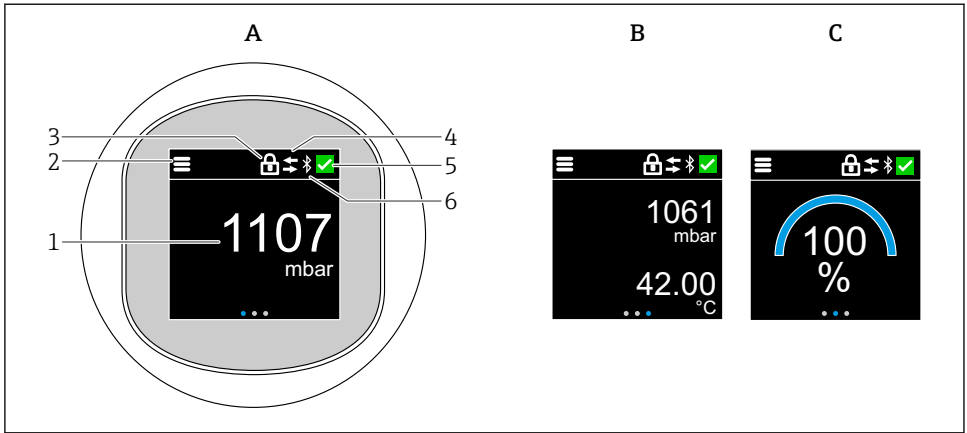

A0052427

- A Standard display: 1 measured value with unit (adjustable)  
 B 2 measured values, each with unit (adjustable)  
 C Graphic measured value display in %  
 1 Measured value  
 2 Menu or home symbol  
 3 Locking (locking only visible if locked via "Safety mode" wizard. "Safety mode" wizard is available if the WHG option has been selected.)  
 4 Communication (symbol appears if communication is enabled)  
 5 Diagnostic symbol  
 6 Bluetooth (symbol flashes when Bluetooth connection is enabled)

The standard display can be permanently set via the operating menu.

### 7.3.1 Operation

#### Navigation

Navigation by swiping with finger.



Operation via the LED indicator is not possible if the Bluetooth connection is enabled.

## Selecting option and confirming

Select the required option and confirm using the checkmark at the top right (see screens below).

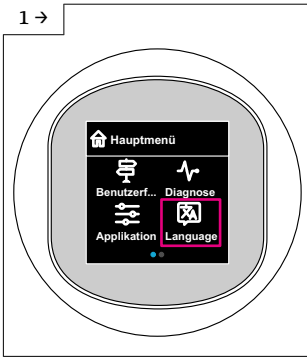

A005284B

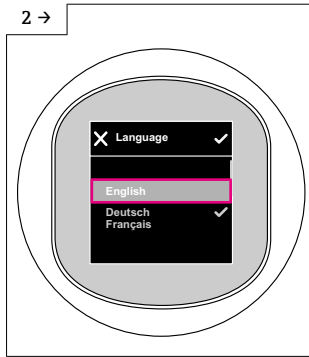

A0052850

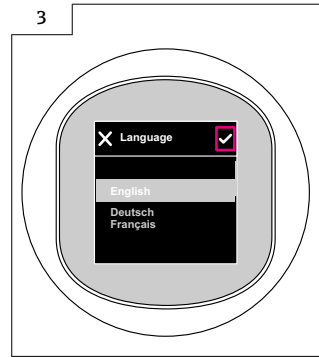

A0052851

## 7.4 Onsite display, locking or unlocking procedure

### 7.4.1 Unlocking procedure

1. Tap the center of the display for the following view:

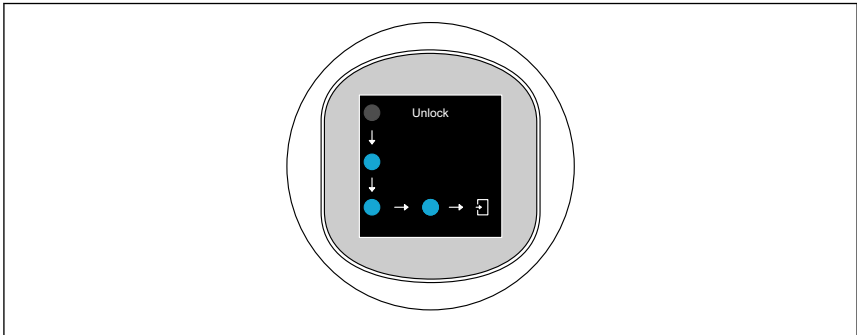

A0052853

2. Use a finger to follow the arrows without interruption.



The display is unlocked.

### 7.4.2 Locking procedure

-  Operation locks automatically (except in **Safety mode** wizard):
  - after 1 min on the main page
  - after 10 min within the operating menu

## 7.5 Operation via SmartBlue App

The device can be operated and configured with the SmartBlue App.

- The SmartBlue App must be downloaded onto a mobile device for this purpose.
- For information on the compatibility of the SmartBlue App with mobile devices, see **Apple App Store (iOS devices)** or **Google Play Store (Android devices)**.
- Incorrect operation by unauthorized persons is prevented by means of encrypted communication and password encryption.
- The Bluetooth® function can be deactivated after initial device setup.

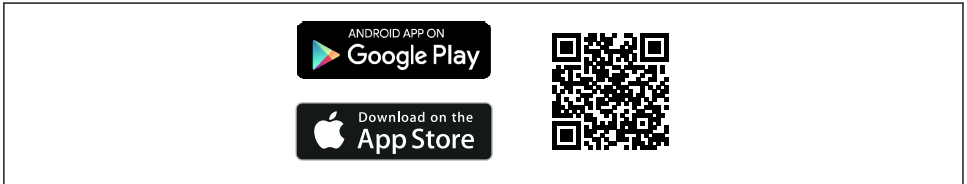



A003202

 1 *QR code for free Endress+Hauser SmartBlue App*

Download and installation:

1. Scan the QR code or enter **SmartBlue** in the search field of the Apple App Store (iOS) or Google Play Store (Android).
2. Install and start the SmartBlue App.
3. For Android devices: enable location tracking (GPS) (not required for iOS devices).
4. Select a device that is ready to receive from the device list displayed.

Login:

1. Enter the user name: admin
  2. Enter the initial password: serial number of the device
-  Change the password after logging in for the first time.
-  Forgotten your password? Contact Endress+Hauser Service.

## 8 Commissioning

### 8.1 Preliminaries



#### WARNING

Settings on the current output can result in a safety-related condition (e.g., product overflow)!

- ▶ Check current output settings.
- ▶ The setting of the current output depends on the setting in the **Assign PV** parameter.

## 8.2 Installation and function check

Before commissioning the measuring point, check that the post-installation and post-connection checks have been performed:

-  "Post-mounting check" section
-  "Post-connection check" section

## 8.3 Overview of commissioning options

- Commissioning via LED display operating key
- Commissioning via onsite display (optional)
- Commissioning with the SmartBlue app
- Commissioning via additional operating tools (AMS, PDM, etc.)

## 8.4 Commissioning via LED display operating key

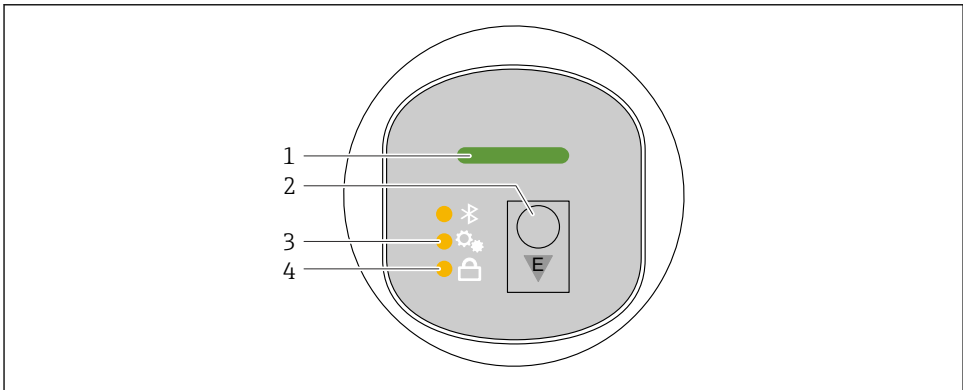

A0053357

- 1 *Operating status LED*
- 2 *Operating key "E"*
- 3 *Position adjustment LED*
- 4 *Keypad lock LED*

1. If necessary, disable the keypad lock (see  section "Access to operating menu via LED display" > "Operation").
2. Repeatedly press the "E" key briefly until the position adjustment LED flashes.
3. Press the "E" key for longer than 4 seconds.
  - ↳ Position adjustment LED is activated.  
The position adjustment LED flashes during activation. The keypad lock LED and Bluetooth LED are off.

Once activated successfully, the position adjustment LED lights up continuously for 12 seconds. The keypad lock LED and Bluetooth LED are off.

If not successfully activated, the position adjustment LED, keypad lock LED and Bluetooth LED flash quickly for 12 seconds.

## 8.5 Commissioning via onsite display

1. If necessary, enable operation (see  section "Onsite display, locking or unlocking procedure" > "Unlocking").
2. Start **Commissioning** wizard (see graphic below).

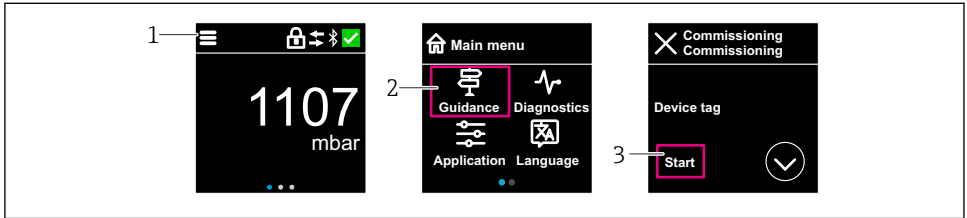

A0053355

- 1 Press the menu icon.
- 2 Press "Guidance" menu.
- 3 Start "Commissioning" wizard.

### 8.5.1 Notes on "Commissioning" wizard

The **Commissioning** wizard enables simple, user-guided commissioning.

1. Once you have started the **Commissioning** wizard, enter the appropriate value in each parameter or select the appropriate option. These values are written directly to the device.
2. Click > to go to the next page.
3. Once all pages have been completed, click OK to close the **Commissioning** wizard.

 If the **Commissioning** wizard is canceled before all necessary parameters have been configured, the device may be in an undefined state. In such situations, it is advisable to reset the device to the factory default settings.

## 8.6 Commissioning via additional operating tools (AMS, PDM, etc.)

Download the device-specific drivers: <https://www.endress.com/en/downloads>

For more details, see the help for the relevant operating tool.

## 8.7 Configuring the operating language

### 8.7.1 Onsite display

#### Configuring the operating language

 Before you can set the operating language, you must first unlock the onsite display:

1. Open the operating menu.
2. Select the Language button.

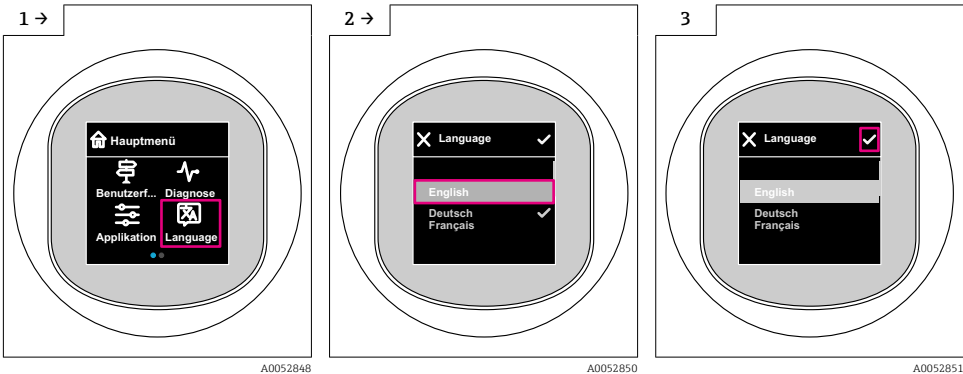

### 8.7.2 Operating tool

Set display language

System → Display → Language

## 8.8 Protecting settings from unauthorized access

### 8.8.1 Software locking or unlocking

#### Locking via password in SmartBlue app

Access to parameter configuration of the device can be locked by assigning a password. When the device is delivered from the factory, the user role is set to **Maintenance** option. The device can be configured completely with the **Maintenance** option user role. Afterwards, access to the configuration can be locked by assigning a password. The **Maintenance** option switches to the **Operator** option as a result of this locking. The configuration can be accessed by entering the password.

The password is defined under:

**System** menu **User management** submenu

The user role is changed from the **Maintenance** option to **Operator** option under:

System → User management

**Canceling the locking procedure via onsite display/SmartBlue app**

After entering the password, you can enable parameter configuration of the device as an **Operator** option with the password. The user role then changes to **Maintenance** option.

If necessary, the password can be deleted in User management: System → User management



71668316

[www.addresses.endress.com](http://www.addresses.endress.com)

---