

# Technical Information

## FieldPort SWA50

Intelligent Bluetooth® and/or WirelessHART adapter for all HART field devices



### Application

The FieldPort SWA50 converts the HART signal of the connected HART field device into a reliable and encrypted Bluetooth® or WirelessHart signal. The SWA50 can be retrofitted to all 2-wire and 4-wire HART field devices in both hazardous and non-hazardous areas. The robust stainless steel housing allows the SWA50 to be installed even in harsh industrial environments.

It is possible to configure the SWA50 and visualize measured values of the connected HART field device via the SmartBlue app or a Field Xpert tablet PC. A FieldEdge device enables quick and easy connection to the Netilion Cloud in order to use the data in various Netilion services.

### Your benefits

- Reliable transmission of the measured process values through the connected FieldPort SWA50 via encrypted Bluetooth® or WirelessHART communication
- Easy to retrofit all 2-wire or 4-wire HART field devices
- Easy connection of all HART field devices to the Netilion Cloud
- Loop-powered adapter, without affecting the process signal
- Easily accessible, wireless, diagnostic information of connected HART field device
- Convenient configuration of the connected HART field device via FieldPort SWA50 and Field Xpert

## Table of contents

<b>About this document</b> . . . . .	<b>3</b>	<b>Accessories</b> . . . . .	<b>16</b>
Symbols . . . . .	3	Device-specific accessories . . . . .	16
<b>Function and system design</b> . . . . .	<b>4</b>	<b>Supplementary documentation</b> . . . . .	<b>18</b>
Function . . . . .	4	Standard documentation SWA50 . . . . .	18
System architecture of the FieldPort SWA50		Supplementary device-dependent documentation for	
Bluetooth version . . . . .	4	SWA50 . . . . .	18
System architecture of FieldPort SWA50 WirelessHART		Standard documentation for SGC200 . . . . .	18
version . . . . .	5	Standard documentation for SGC500 . . . . .	18
		Standard documentation for SMT50 . . . . .	18
		Standard documentation for SMT70 . . . . .	18
		Standard documentation for SMT77 . . . . .	19
		Standard documentation for SWA70 . . . . .	19
		Standard documentation for SWG50 . . . . .	19
<b>Input (wired interface)</b> . . . . .	<b>5</b>	<b>Radio approvals</b> . . . . .	<b>19</b>
Inputs . . . . .	5	Europe . . . . .	19
Communication interface and protocol version . . . . .	5	Canada and United States . . . . .	19
		Brasil . . . . .	20
		México . . . . .	20
		UAE . . . . .	20
		Qatar . . . . .	20
		Japan . . . . .	20
		Thailand . . . . .	20
		Indonesia . . . . .	21
		Singapore . . . . .	21
		South Korea . . . . .	21
		Other radio approvals . . . . .	21
<b>Output (wireless interface)</b> . . . . .	<b>6</b>		
Communication interface . . . . .	6		
Transmission frequency band . . . . .	6		
Range . . . . .	6		
Transmission power . . . . .	6		
Device variables . . . . .	7		
Diagnosis . . . . .	7		
<b>Power supply</b> . . . . .	<b>8</b>		
Electrical connection . . . . .	8		
Terminal assignment . . . . .	10		
FieldPort SWA50 grounding . . . . .	10		
Supply voltage . . . . .	11		
Power consumption . . . . .	11		
Terminals . . . . .	11		
Cable entry . . . . .	11		
Cable specification . . . . .	11		
<b>Mounting</b> . . . . .	<b>12</b>		
Mounting methods . . . . .	12		
Mounting instructions . . . . .	13		
Lightning protection . . . . .	13		
<b>Environment</b> . . . . .	<b>13</b>		
Ambient temperature range . . . . .	13		
Storage temperature range . . . . .	13		
Climate class . . . . .	13		
Degree of protection . . . . .	13		
Vibration resistance . . . . .	13		
Shock resistance . . . . .	13		
Electromagnetic compatibility (EMC) . . . . .	13		
<b>Mechanical construction</b> . . . . .	<b>14</b>		
Design, dimensions . . . . .	14		
Weight . . . . .	15		
Materials . . . . .	15		
<b>Operability</b> . . . . .	<b>15</b>		
Operating concept . . . . .	15		
Local operation . . . . .	15		
<b>Certificates and approvals</b> . . . . .	<b>16</b>		

## About this document

### Symbols

#### Safety symbols

** DANGER**

This symbol alerts you to a dangerous situation. Failure to avoid this situation will result in serious or fatal injury.

** WARNING**

This symbol alerts you to a dangerous situation. Failure to avoid this situation can result in serious or fatal injury.









** CAUTION**

This symbol alerts you to a dangerous situation. Failure to avoid this situation can result in minor or medium injury.

** NOTICE**

This symbol contains information on procedures and other facts which do not result in personal injury.

#### Symbols for certain types of information

Symbol	Meaning
	<b>Permitted</b> Procedures, processes or actions that are permitted.
	<b>Preferred</b> Procedures, processes or actions that are preferred.
	<b>Forbidden</b> Procedures, processes or actions that are forbidden.
	<b>Tip</b> Indicates additional information.
	Reference to documentation
	Reference to page
	Reference to graphic
	Visual inspection

## Function and system design

### Function

The FieldPort SWA50 converts the HART signal of the connected HART field device into a reliable and encrypted Bluetooth® or WirelessHart signal. The FieldPort SWA50 can be retrofitted to all 2-wire or 4-wire HART field devices.

The following operating tools are available for the FieldPort SWA50:

- The Endress+Hauser SmartBlue app for mobile devices
- An Endress+Hauser Field Xpert SMTxx tablet PC
- The Endress+Hauser FieldCare SFE500 field device configuration tool

Depending on the operating tool, the following functions are available:

- Configuration of the FieldPort SWA50
- Visualization of the measured values of the connected HART field device
- Visualization of the current status of the FieldPort SWA50 and the connected HART field device
- Configuration of the connected HART field device

HART field devices can be connected to the Netilion Cloud via the FieldPort SWA50 and a FieldEdge device.

 Detailed information on Netilion Cloud: <https://netilion.endress.com>

The WirelessHART version of the FieldPort SWA50 can be integrated into a WirelessHART network via the Endress+Hauser FieldGate SWG50 or via any compatible WirelessHART gateway. More information is available from your Endress+Hauser sales organization: [www.addresses.endress.com](http://www.addresses.endress.com).

### NOTICE

#### Safety applications with control functions via Bluetooth signal or WirelessHART signal

Undesirable behavior of safety application

- ▶ Do not use a wireless signal such as Bluetooth or WirelessHART in a safety application with a control function.

### System architecture of the FieldPort SWA50 Bluetooth version

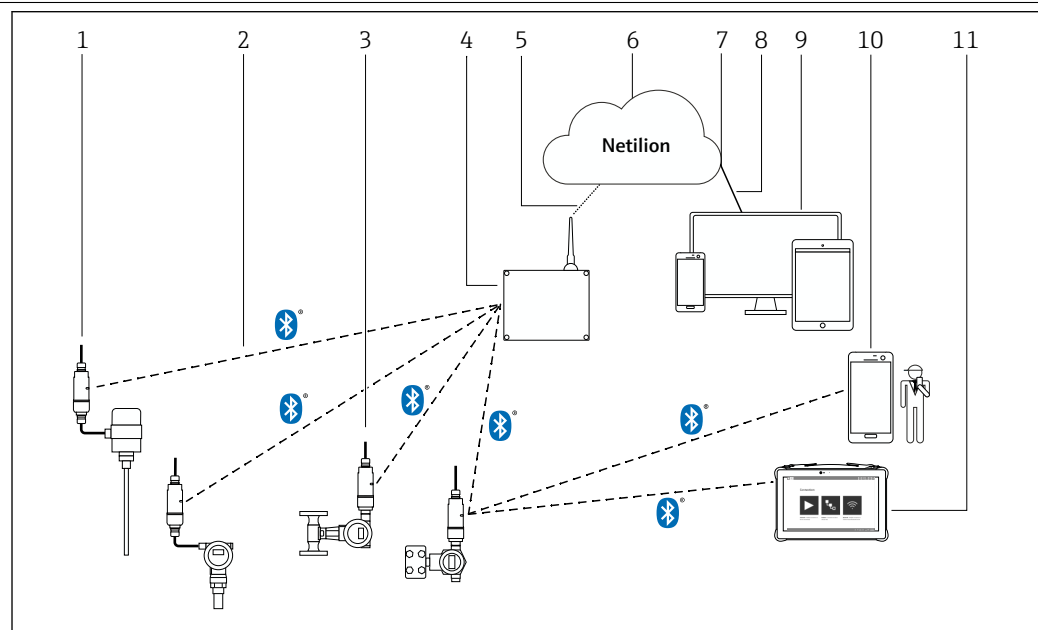

 1 System architecture of SWA50 Bluetooth version

- 1 HART field device with FieldPort SWA50, remote mounting
- 2 Encrypted wireless connection via Bluetooth®
- 3 HART field device with FieldPort SWA50, direct mounting
- 4 FieldEdge SGC200
- 5 LTE connection
- 6 Netilion Cloud
- 7 Application Programming Interface (API)
- 8 https Internet connection
- 9 Internet browser-based Netilion Service app or user application
- 10 Endress+Hauser SmartBlue app
- 11 Endress+Hauser Field Xpert, e.g. SMTxx

**System architecture of FieldPort SWA50 WirelessHART version**

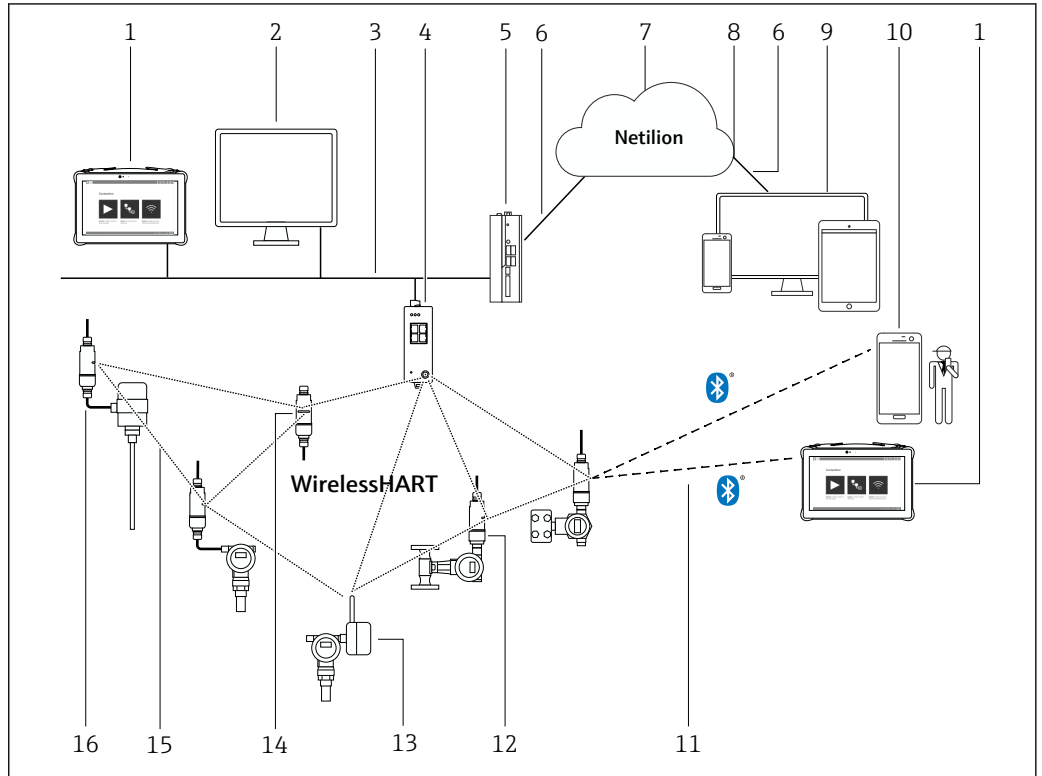

A0043239

2 System architecture of SWA50 WirelessHART version

- 1 Endress+Hauser Field Xpert such as SMTxx
- 2 Host application / FieldCare SFE500
- 3 Ethernet communication
- 4 WirelessHART gateway, e.g. FieldGate SWG50
- 5 FieldEdge SGC500
- 6 https Internet connection
- 7 Netilion cloud
- 8 Application Programming Interface (API)
- 9 Internet browser-based Netilion Service app or user application
- 10 Endress+HauserSmartBlue app
- 11 Encrypted wireless connection via Bluetooth®
- 12 HART field device with FieldPort SWA50, direct mounting
- 13 HART field device with WirelessHART adapter, e.g., SWA70
- 14 FieldPort SWA50 as repeater
- 15 Encrypted wireless connection via WirelessHART
- 16 HART field device with FieldPort SWA50, remote mounting

## Input (wired interface)

**Inputs**

A point-to-point connection to a 2-wire or 4-wire HART field device

**Communication interface and protocol version**

Field devices with HART 5, HART 6 or HART 7

## Output (wireless interface)

### Communication interface

#### Bluetooth

Bluetooth IEEE 802.15.1

**i** In addition to the FieldPort SWA50, there can be only one other HART master in the HART loop of the SWA50.

#### WirelessHART

- WirelessHART communication interface (IEC 62591)
- HART version 7.5, backward-compatible with previous HART versions

### Transmission frequency band

2.4 GHz (ISM band)

### Range

**i** The range depends on the alignment of the FieldPort SWA50, the mounting location and the environmental conditions.

Since the antenna of the WirelessHART gateway is aligned vertically as a general rule, the ideal orientation for the FieldPort SWA50 is also vertical. If the antennas are aligned differently, this can greatly reduce the antenna range.

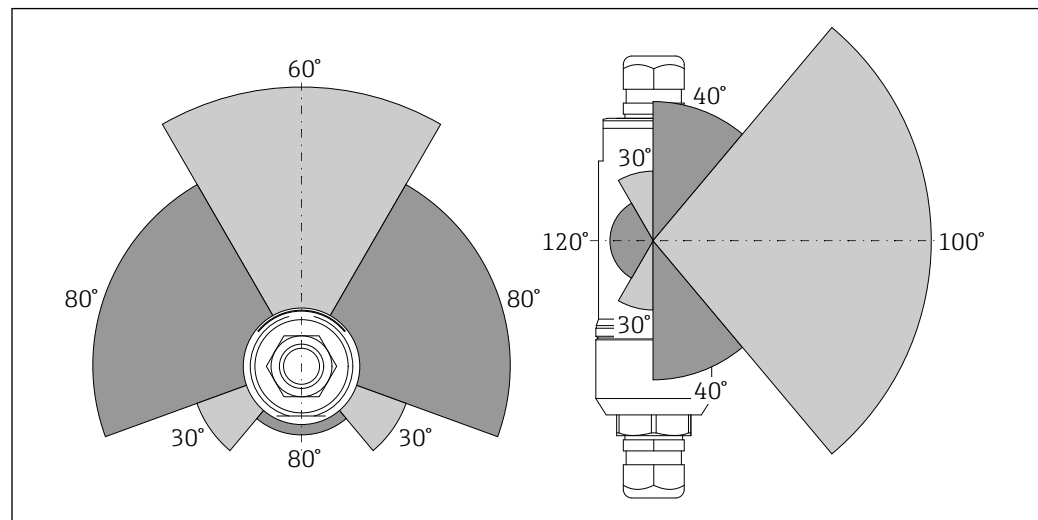

**3** Different ranges depending on the position of the transmission window

#### Bluetooth

Up to 30 m (98 ft) without obstacles when FieldPort SWA50 is optimally aligned

#### WirelessHART

- Up to 175 m (574 ft) without obstacles, between FieldGate SWG50 with 6 dBi antenna and FieldPort SWA50, optimally aligned
- Up to 75 m (246 ft) without obstacles, between FieldGate SWG50 with 2 dBi antenna and FieldPort SWA50, optimally aligned
- Up to 50 m (146 ft) without obstacles, between WirelessHART adapter SWA70 and FieldPort SWA50, optimally aligned
- Up to 25 m (82 ft) without obstacles, between two FieldPort SWA50 adapters, optimally aligned

### Transmission power

0 dBm or 10 dBm, configurable for adaptation to national regulations

Device variables



	SmartBlue app	Field Xpert
<b>Endress+Hauser field devices</b>	<ul style="list-style-type: none"> <li>■ Measured value output current of HART field device</li> <li>■ Device information, configuration data and HART information of the FieldPort SWA50</li> <li>■ Measured values PV, SV, TV and QV of HART field device</li> <li>■ Additional device information of the HART-7 or HART-6 field device</li> <li>■ HART information of HART field device</li> <li>■ Combined NAMUR NE 107 status, consisting of the status for the FieldPort SWA50 and the status of the connected HART field device</li> </ul>	<ul style="list-style-type: none"> <li>■ Measured value output current of HART field device</li> <li>■ Device information, configuration data and HART information of the FieldPort SWA50</li> <li>■ Measured values PV, SV, TV and QV of HART field device</li> <li>■ Additional device information of the HART-7 or HART-6 field device</li> <li>■ HART information of HART field device</li> <li>■ Combined NAMUR NE 107 status, consisting of the status for the FieldPort SWA50 and the status of the connected HART field device</li> </ul>
<b>Field devices of other manufacturers</b>	<ul style="list-style-type: none"> <li>■ Measured value output current of HART field device</li> <li>■ Device information, configuration data and HART information of the FieldPort SWA50</li> </ul>	<ul style="list-style-type: none"> <li>■ Measured value output current of HART field device</li> <li>■ Device information, configuration data and HART information of the FieldPort SWA50</li> </ul> <p>Additionally in the livelist</p> <ul style="list-style-type: none"> <li>■ Measured values PV and SV</li> <li>■ Combined NAMUR NE 107 status, consisting of the status for the FieldPort SWA50 and the status of the connected HART field device</li> </ul>

 If the HART field device does not support the extended device status according to NAMUR NE 107, limitations may apply to the display of status information.

**You can read out the following data via the Bluetooth version of the FieldPort SWA50 and the Endress+Hauser FieldEdge SGC200 (Netilion services):**

- Process variables PV and SV of HART field device if available
- Combined status according to NAMUR NE 107 of the FieldPort SWA50 and the HART field device, where available

**For the WirelssHART version of the FieldPort SWA50 and the Endress+HauserFieldEdge SGC500(Netilion Cloud)**

 For detailed information, see the Operating Instructions for the FieldPort SWA50 WirelessHART →  18

Diagnosis

2 LEDs

- Green: Flashes four times at start-up to indicate that the device is operational
- Orange: Flashes every 2 seconds to indicate that a squawk function has been enabled

The LEDs are located on the electronic insert and are not visible from the outside.

## Power supply

### Electrical connection

#### 2-wire HART field device with passive current output

**i** Some grounding concepts require shielded cables. If connecting the cable shield to the FieldPort SWA50, you must use a cable gland for shielded cable. See ordering information.

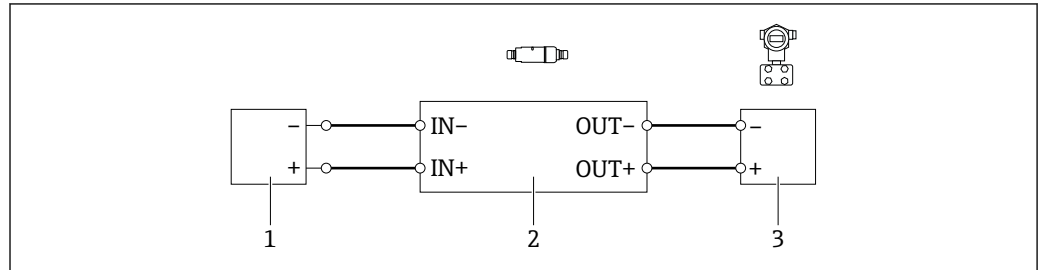

A0040494

**4** Electrical connection for 2-wire HART field devices with passive current output (optional grounding not shown)

- 1 Supply voltage (SELV, PELV or Class 2) or PLC with active current input or transmitter with active current input
- 2 Electronic insert SWA50
- 3 2-wire field device 4 to 20 mA-HART

#### 4-wire HART field device with passive current output

**i** Some grounding concepts require shielded cables. If connecting the cable shield to the FieldPort SWA50, you must use a cable gland for shielded cable. See ordering information.

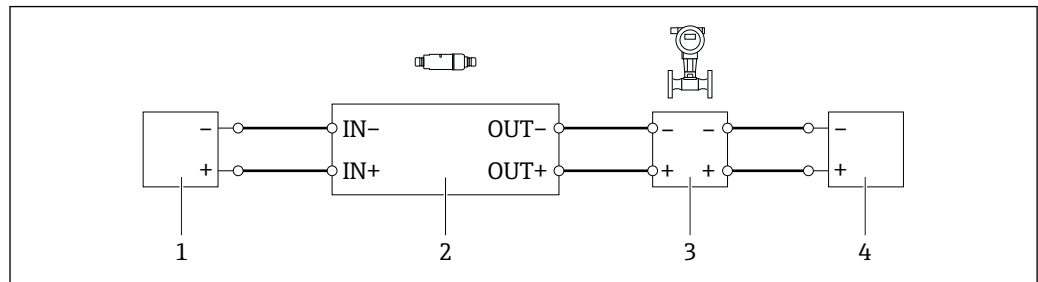

A0040491

**5** Electrical connection for 4-wire HART field devices with passive current output (optional grounding not shown)

- 1 Supply voltage (SELV, PELV or Class 2) or PLC with active current input or transmitter with active current input
- 2 Electronic insert SWA50
- 3 4-wire field device with passive 4 to 20 mA-HART output
- 4 Supply voltage for 4-wire field device

#### 4-wire HART field device with active current output

**i** Some grounding concepts require shielded cables. If connecting the cable shield to the FieldPort SWA50, you must use a cable gland for shielded cable. See ordering information.



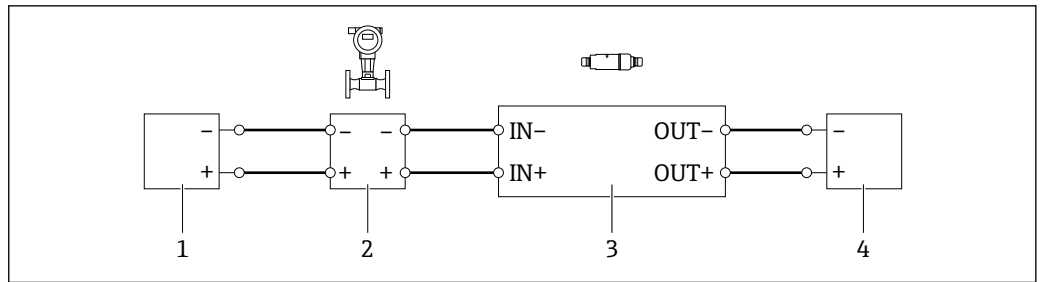

A0040492

6 Electrical connection for 4-wire HART field devices with active current output (optional grounding not shown) - PLC or transmitter at OUT terminals

- 1 Supply voltage (SELV, PELV or Class 2) for 4-wire HART field device
- 2 4-wire field device with active 4 to 20 mA HART output
- 3 Electronic insert SWA50
- 4 PLC or transmitter with passive current input

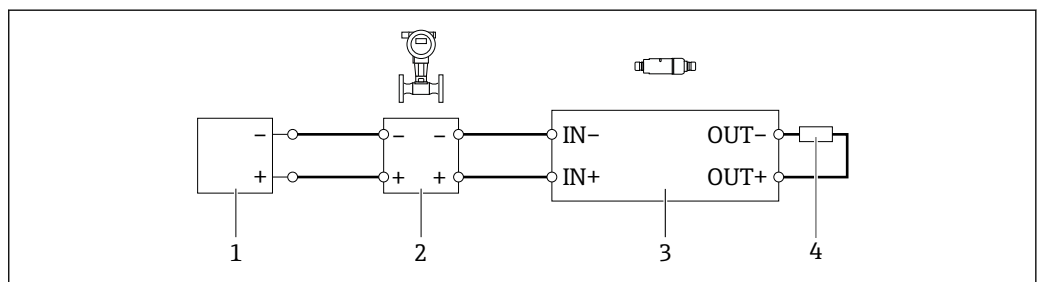

A0045101

7 Electrical connection for 4-wire HART field devices with active current output (optional grounding not shown) - resistor at OUT terminals

- 1 Supply voltage (SELV, PELV or Class 2) for 4-wire HART field device
- 2 4-wire field device with active 4 to 20 mA HART output
- 3 Electronic insert SWA50
- 4 Resistance 250 to 500 Ohm min. 250 mW between terminals OUT+ and OUT-

**i** If you select the "direct mounting" version and the "4-wire HART field device with active current output and PLC or transmitter" electrical connection version, you can use core cross-sections of 0.75 mm<sup>2</sup> maximum. The wires that you insert into the shorter top housing section must be connected to the IN terminals opposite, and the wires that you insert into the longer bottom housing section must be connected to the OUT terminals opposite. If larger core cross-sections are required, we recommend remote mounting.

#### FieldPort SWA50 without HART field device (repeater)

**i** Using this connection version, you can preconfigure the FieldPort SWA50 or use it as a repeater.

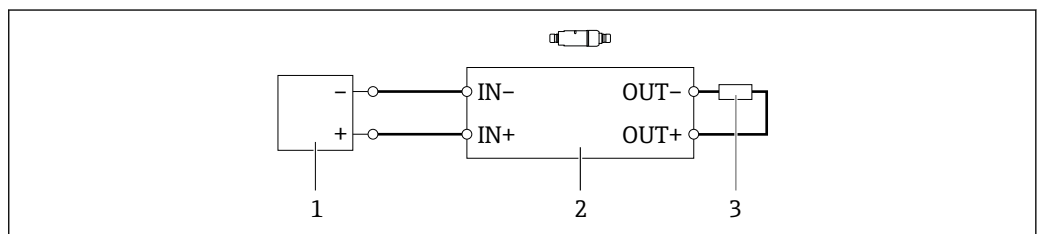

A0040493

8 FieldPort SWA50 without HART field device (optional grounding not shown)

- 1 Supply voltage FieldPort SWA50, 20 to 30 VDC (SELV, PELV or Class 2)
- 2 Electronic insert SWA50
- 3 Resistance 1.5 kOhm and min. 0.5 W between terminals OUT+ and OUT-

## Terminal assignment

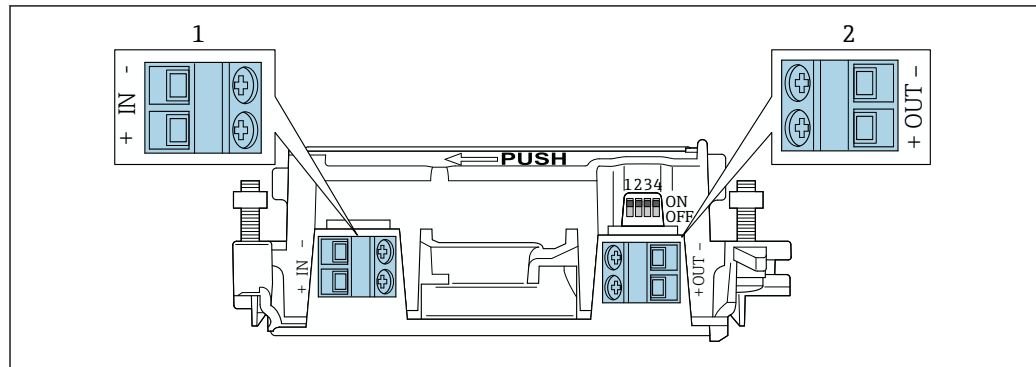

9 FieldPort SWA50 terminal assignment

- 1 Input terminal IN  
2 Output terminal OUT

Application	Input terminal IN	Output terminal OUT
2-wire HART field device → 4, 8	Cable from supply voltage, PLC with active current output or transmitter with active current output	Cable to 2-wire HART field device
4-wire HART field device with passive current output → 5, 8	Cable from supply voltage, PLC with active current output or transmitter with active current output	Cable to 4-wire HART field device
4-wire HART field device with active current output → 8	Cable from 4-wire field device with active 4 to 20 mA HART output	PLC or transmitter with passive current output (optional), alternatively wire bridge between terminals OUT+ and OUT-
FieldPort SWA50 without field device → 8, 9	Cable from supply voltage for FieldPort SWA50	Resistor between terminals OUT+ and OUT-

## FieldPort SWA50 grounding

**"Direct mounting" version**

With the "direct mounting" version, the FieldPort SWA50 is grounded via the field device or the metal conduit.

**"Remote mounting" version**

With the "remote mounting" version, ground the FieldPort SWA50 via the optional mounting bracket or a grounding clamp provided by the customer.

*Optional mounting bracket*

If using the mounting bracket, ground the FieldPort SWA50 via the grounding screw.

**i** Mounting bracket: → 16

*Grounding clamp provided by customer*

The grounding clamp provided by the customer must meet the following requirements:

- Diameter: approx. 40 mm
- Stainless steel
- If the FieldPort SWA50 is used in a hazardous area: suitable for hazardous areas as per DIN EN 62305, Sheet 3 and DIN EN 62561-1

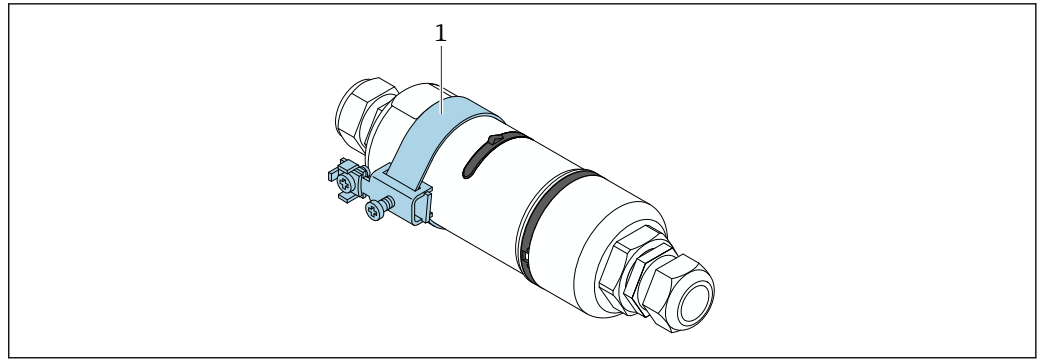

A0041808

10 Grounding via grounding clamp

1 Example of grounding clamp provided by customer

### Supply voltage

- Loop-powered 4 to 20 mA
- 24 V DC (min. 4 V DC, max. 30 V DC): min. 3.6 mA loop current required for start-up
- The supply voltage or the power unit must be tested to ensure it meets safety requirements and the requirements for SELV, PELV or Class 2

#### Voltage drop

- If internal HART communication resistor is deactivated
  - 3.2 V in operation
  - < 3.8 V at start-up
- If internal HART communication resistor is activated (270 Ohm)
  - < 4.2 V at 3.6 mA loop current
  - < 9.3 V at 22.5 mA loop current

**i** To select the supply voltage, pay attention to the voltage drop via the FieldPort SWA50. The remaining voltage must be high enough to enable the start-up and operation of the HART field device.

### Power consumption

Max. 0.2 W at 22 mA and with internal HART communication resistor (270 Ohm)

### Terminals

2 x 2-pin screw terminals

### Cable entry

- "Remote mounting" version: 2 cable glands
- "Direct mounting" version: 1 cable gland and 1 direct cable entry from field device

#### The following cable glands are available.

- Plastic M20 for unshielded cable (only suitable for use in non-hazardous areas)
- Brass M20 for unshielded cable
- Brass M20 for shielded cable

### Cable specification

Use cables that are suitable for the anticipated minimum and maximum temperatures.

Observe grounding concept of the plant.

2 x 0.25 mm<sup>2</sup> to 2 x 1.5 mm<sup>2</sup>

You can use unshielded cable with or without ferrules and shielded cable with or without ferrules.

**i** If you select the "direct mounting" version and the "4-wire HART field device with active current output and PLC or transmitter" electrical connection version, you can use core cross-sections of 0.75 mm<sup>2</sup> at maximum. If larger core cross-sections are required, we recommend remote mounting.

## Mounting

### Mounting methods

- Remote mounting
- Direct mounting on HART field device via either M20 or NPT 1/2" connection adapter

For remote mounting, we recommend the optional mounting bracket. Alternatively, you can secure the remote version using pipe clips.

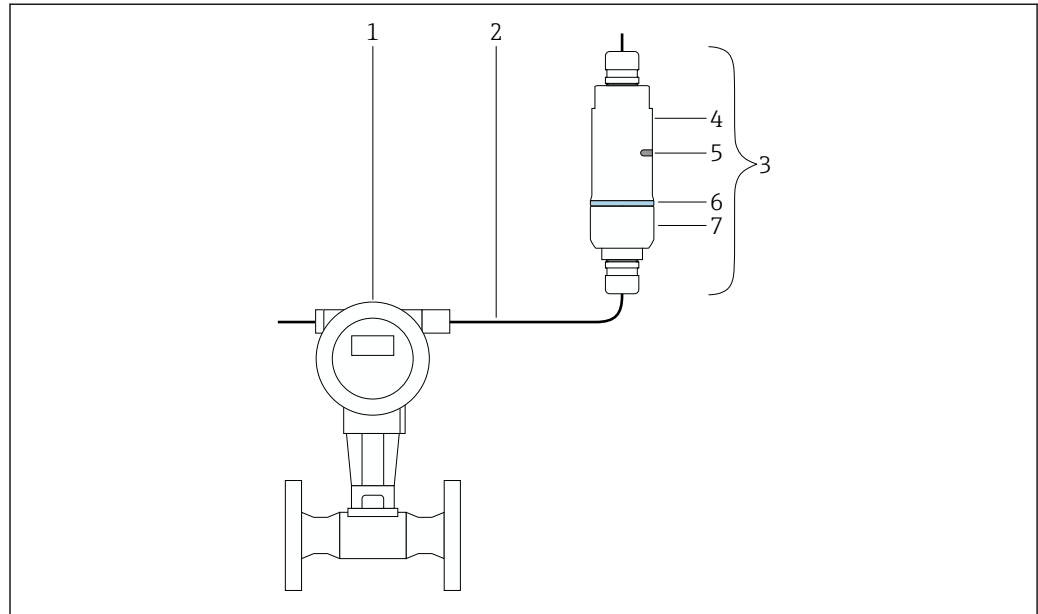

A0043240

11 Example of remote mounting

- 1 HART field device
- 2 Cable
- 3 FieldPort SWA50 "remote mounting" version
- 4 Bottom housing section
- 5 Transmission window
- 6 Design ring
- 7 Top housing section

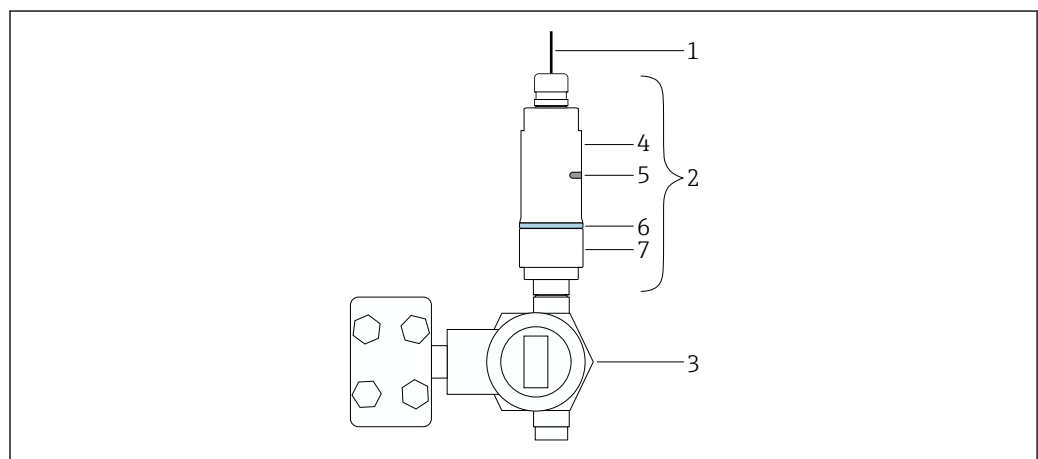



A0043241

12 Example of direct mounting

- 1 Cable
- 2 FieldPort SWA50 "direct mounting" version
- 3 HART field device
- 4 Bottom housing section
- 5 Transmission window
- 6 Design ring
- 7 Top housing section

**Mounting instructions**

- Pay attention to the alignment and range. →  6
- Observe a distance of at least 6 cm (0.24 ft) from walls and pipes. Pay attention to the expansion of the Fresnel zone.
- Avoid mounting in close proximity to high-voltage devices.
- Pay attention to the effect of vibrations at the mounting location. →  13

Additional mounting information for Bluetooth version:

Mount within the visual range of a FieldEdge SGC200.

Additional mounting information for WirelessHART version:

Mount within the visual range of a WirelessHart network subscriber.

---

**Lightning protection**

- Do not mount the FieldPort SWA50 at the highest point of the system.
- Ground the housing of the FieldPort SWA50.

## Environment

---

**Ambient temperature range**    -40 to +70 °C (-40 to +158 °F)

---

**Storage temperature range**    -40 to +85 °C (-40 to +185 °F)

---

**Climate class**    As per IEC 60068-2-38 test Z/AD

---

**Degree of protection**

When housing is closed, tested according to:

- IP68 / NEMA 6P (24 h at 1 m under water)
- IP66 / NEMA 4X

---

**Vibration resistance**

As per IEC 60068-2-64:2008

- a(RMS) = 50 m/s<sup>2</sup>
- f = 5 to 2000 Hz
- t = 3 planes x 2 h



Vibration resistance tested only for "remote mounting" version.

---

**Shock resistance**

As per IEC 60068-2-27:2008

300 m/s<sup>2</sup> [= 30 gn] + 18 ms

---

**Electromagnetic compatibility (EMC)**

Electromagnetic compatibility as per EN 61326 series and NAMUR recommendation EMC (NE 21)

## Mechanical construction

### Design, dimensions

#### "Remote mounting" version

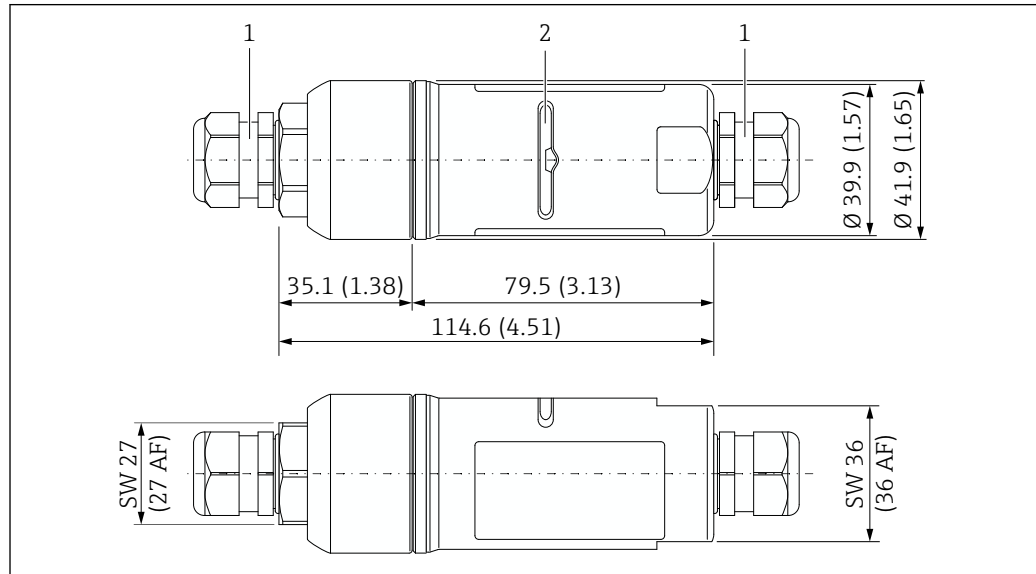

A0040484

13 Dimensions of "remote mounting" version in mm (in)

- 1 M20 cable gland
- 2 Transmission window

#### "Direct mounting" version

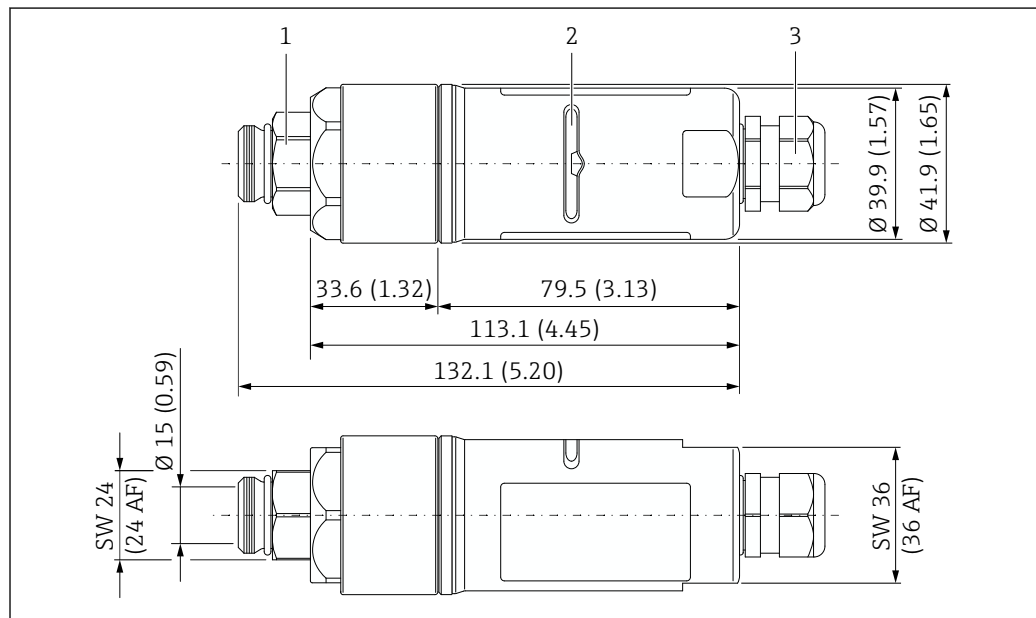

A0040483

14 Dimensions of "direct mounting with M20" version in mm (in)

- 1 Connection adapter with M20 thread
- 2 Transmission window
- 3 M20 cable gland

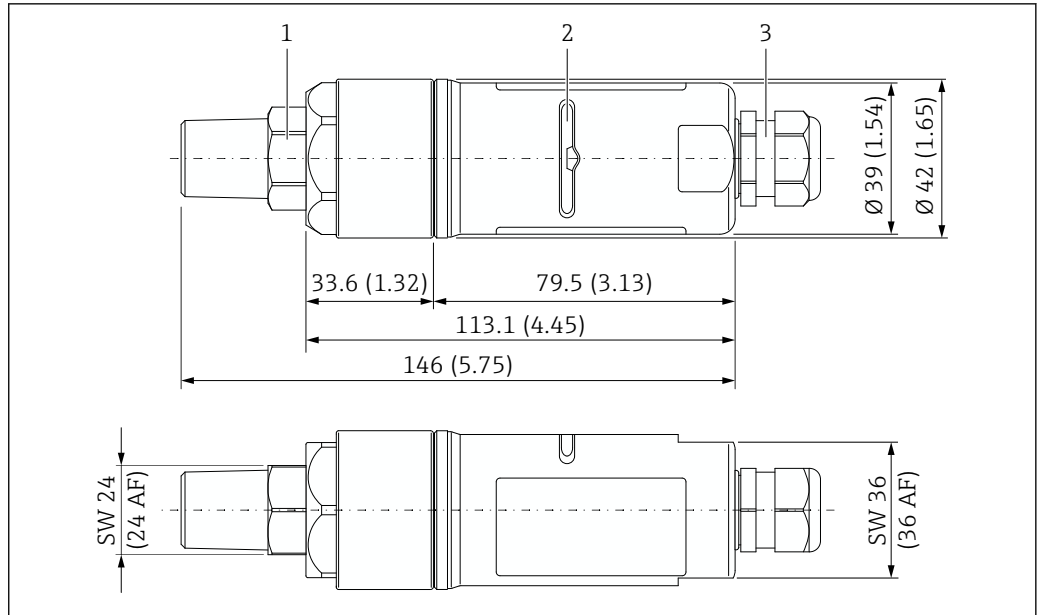

15 Dimensions of "direct mounting with NPT" version in mm (in)

- 1 Connection adapter with 1/2 NPT thread
- 2 Transmission window
- 3 M20 cable gland

**Weight** Max. 500 g

**Materials**  
**Housing**  
 Stainless steel 1.4404 (316L)

**Cable glands**  
 Plastic or brass, depending on the version. See ordering information.

**Connection adapter**

- M20 thread: stainless steel. 1.4404 (316L)
- NPT 1/2" thread: stainless steel. 1.4404 (316L)

**Seals**

- Design ring (housing – cover seal): PC
- O-ring: EPDM
- Transmission window seal: silicone

## Operability

**Operating concept** You have the following options to operate the FieldPort SWA50:

- Via the Endress+Hauser SmartBlue app for mobile devices
- Via an Endress+Hauser Field Xpert SMTxx tablet PC
- Via the Endress+Hauser FieldCare SFE500 field device configuration tool

**Local operation** You can enable and disable the following functions via DIP switches.

- Bluetooth communication
- Firmware update
- Configuration via Bluetooth

The DIP switches are located on the electronic insert.

## Certificates and approvals

Current certificates and approvals for the product are available at [www.endress.com](http://www.endress.com) on the relevant product page:

1. Select the product using the filters and search field.
2. Open the product page.
3. Select **Downloads**.

## Accessories

Various accessories are available for the device, and can be ordered with the device or at a later stage from Endress+Hauser. Detailed information on the specific order code is available from your local Endress+Hauser sales organization or on the product page of the Endress+Hauser website: [www.endress.com](http://www.endress.com).

### Device-specific accessories

#### Mounting bracket

Order number  
71520242

Material  
Stainless steel 1.4404 (316L)

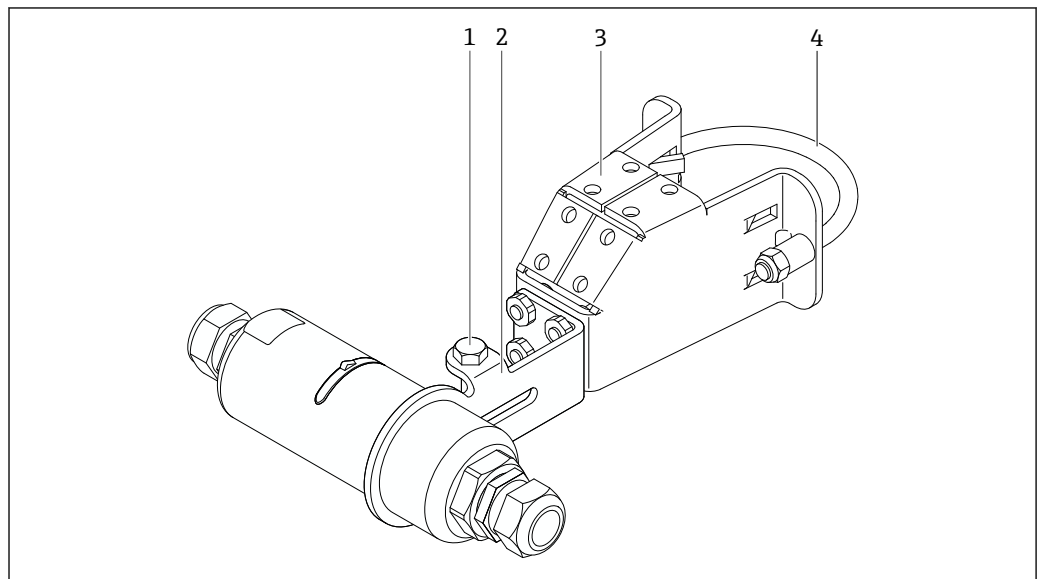

A0043312

16 FieldPort SWA50 mounted via optional mounting bracket

- 1 Hexagonal-headed bolt for securing and grounding
- 2 Support bracket
- 3 Mounting bracket
- 4 Round bracket

#### Mounting and alignment options

The mounting bracket can be mounted as follows:

- On pipes with a maximum diameter of 65 mm
- On walls

The FieldPort can be aligned as follows using the support bracket:

- Via the various mounting positions on the mounting bracket
- By rotating the support bracket



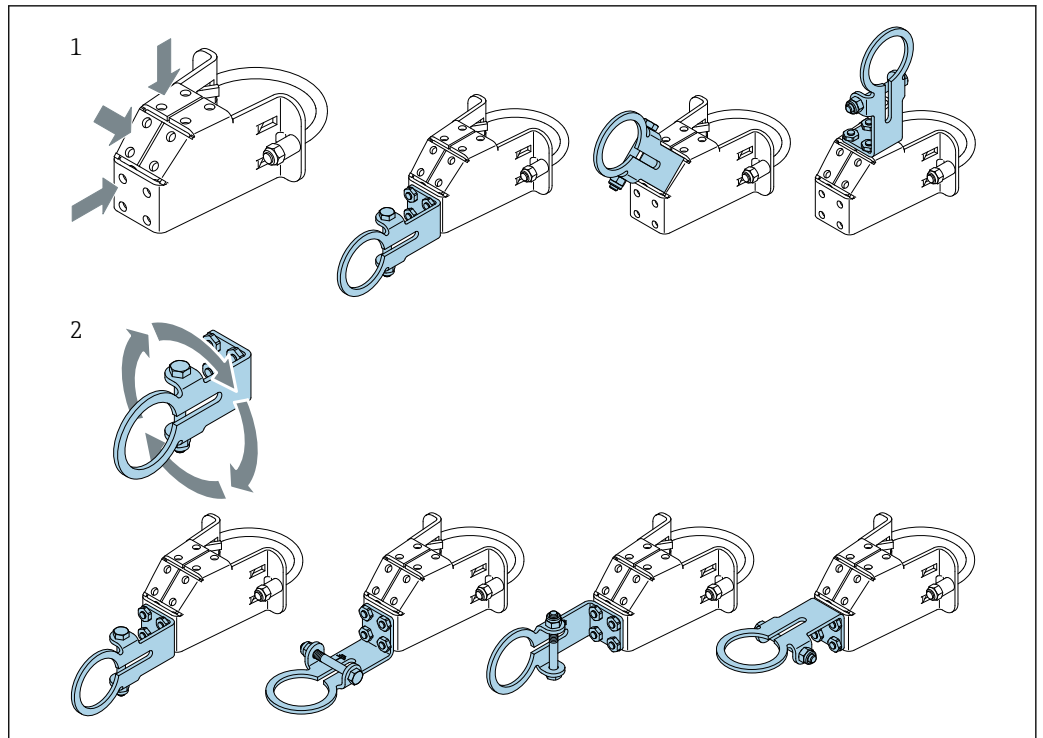

A0043411

17 Alignment options via support bracket

- 1 Various mounting positions on support bracket
- 2 By rotating the support bracket

Dimensions

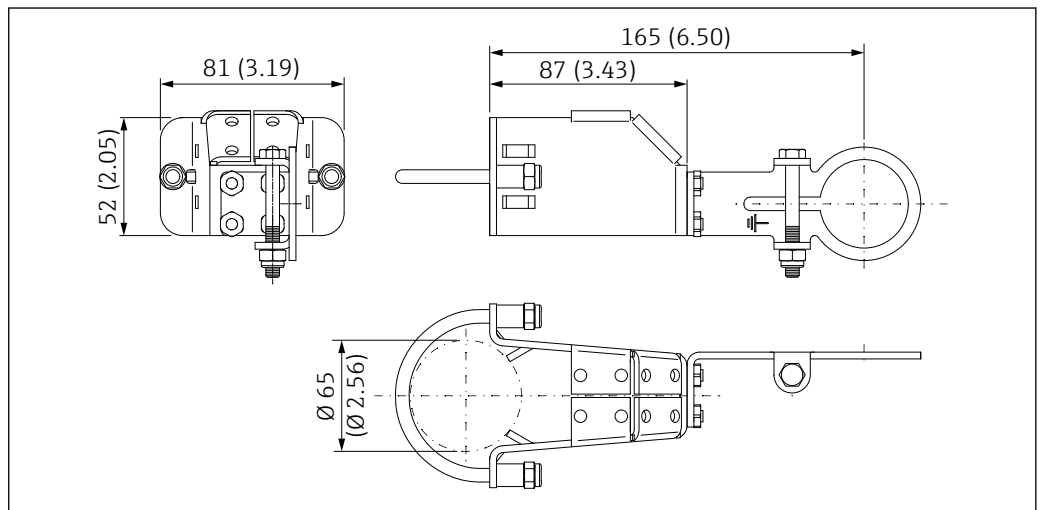

A0043313

18 Dimensions of mounting bracket - pipe mounting

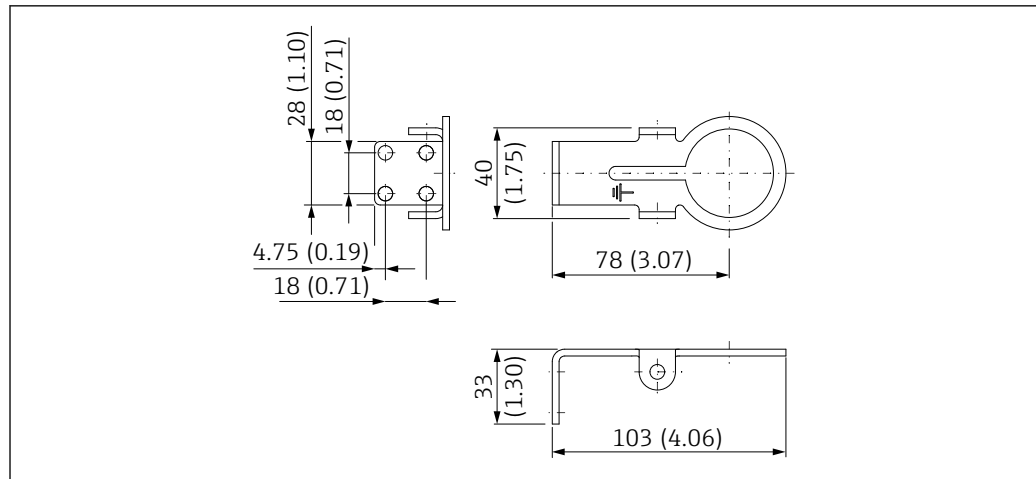

A0043410

19 Dimensions of retaining bracket – wall mounting

## Supplementary documentation

### Standard documentation SWA50

#### Operating Instructions

- Bluetooth: BA01987S
- WirelessHART: BA02046S

#### Brief Operating Instructions

- Bluetooth: KA01707S
- WirelessHART: KA01436S

#### Security Manual

SD02984S

 [www.endress.com/SWA50](http://www.endress.com/SWA50)

### Supplementary device- dependent documentation for SWA50

All explosion-protection data are provided in separate Ex documentation. The relevant Ex documentation is delivered with the Ex devices as standard. You can also find the Ex documentation via the Product Configurator →  16.

### Standard documentation for SGC200

#### Technical Information

TI01468S

#### Operating Instructions

BA02058S

### Standard documentation for SGC500

#### Technical Information

TI01525S

#### Operating Instructions

BA02035S

### Standard documentation for SMT50

#### Technical Information

TI01555S

#### Operating Instructions

BA02053S

### Standard documentation for SMT70

#### Technical Information

TI01342S

#### Operating Instructions

BA01709S

---

<b>Standard documentation for SMT77</b>	<b>Technical Information</b> TI01418S <b>Operating Instructions</b> BA01923S
---	---

---

<b>Standard documentation for SWA70</b>	<b>Technical Information</b> TI00026S <b>Operating Instructions</b> BA00061S
---	---

---

<b>Standard documentation for SWG50</b>	<b>Technical Information</b> TI01677S <b>Operating Instructions</b> BA02235S
---	---

## Radio approvals

---

<b>Europe</b>	This device meets the requirements of the Radio Equipment Directive RED 2014/53/EU. The applicable standards are listed in the EU declaration of conformity.
---------------	--

---

<b>Canada and United States</b>	<p>FCC ID: LCGSWA50</p> <p>IC: 2519A-SWA50</p> <p>This device complies with Part 15 of the FCC Rules and with Industry Canada license-exempt RSS standard(s).</p> <p>Operation is subject to the following two conditions:</p> <ul style="list-style-type: none"><li>▪ this device may not cause harmful interference, and</li><li>▪ this device must accept any interference received, including interference that may cause undesired operation.</li></ul> <p> Changes or modifications made to this equipment not expressly approved by Endress+Hauser SE+Co. KG may void the FCC authorization to operate this equipment.</p> <p>This device has been tested and found to comply with the limits for a Class B digital device, pursuant to Part 15 of the FCC Rules. These limits are designed to provide reasonable protection against harmful interference in a residential installation. This equipment generates, uses and can radiate radio frequency energy and, if not installed and used in accordance with the instructions, may cause harmful interference to radio communications. However, there is no guarantee that interference will not occur in a particular installation.</p> <p>If this equipment does cause harmful interference to radio or television reception, which can be determined by turning the equipment off and on, the user is encouraged to try to correct the interference by one or more of the following measures:</p> <ul style="list-style-type: none"><li>▪ reorient or relocate the receiving antenna</li><li>▪ increase the separation between the equipment and receiver</li><li>▪ connect the equipment into an outlet on a circuit different from that to which the receiver is connected</li><li>▪ consult the dealer or an experienced radio/TV technician for help with radiofrequency radiation exposure information.</li></ul> <p>This equipment complies with FCC and IC radiation exposure limits set forth for an uncontrolled environment. This equipment should be installed and operated with a minimum distance of 20 cm (7.87 in) between the radiator and your body.</p> <p>This transmitter must not be co-located or operating in conjunction with any other antenna or transmitter.</p> <p>Changes or modifications made to this device that are not expressly approved by Endress+Hauser may void the FCC authorization to operate this device. This device must be installed to ensure a minimum antenna separation distance of 20 cm from all persons.</p>
---------------------------------	--

### Français

Le présent appareil est conforme aux CNR d'industrie Canada applicables aux appareils radio exempts de licence.

L'exploitation est autorisée aux deux conditions suivantes :

- L'appareil ne doit pas produire de brouillage, et
- L'utilisateur de l'appareil doit accepter tout brouillage radioélectrique subi, même si le brouillage est susceptible d'en compromettre le fonctionnement.

 Les changements ou modifications apportées à cet appareil non expressément approuvée par Endress+Hauser SE+Co. KG peut annuler l'autorisation FCC d'utiliser cet appareil.

Déclaration d'exposition aux radiations

Cet équipement est conforme aux limites d'exposition aux rayonnements IC établies pour un environnement non contrôlé. Cet équipement doit être installé et utilisé avec un minimum de 20 cm (7.87 in) de distance entre la source de rayonnement et votre corps.

Ce transmetteur ne doit pas être placé au même endroit ou utilisé simultanément avec un autre transmetteur ou antenne.

## Brasil

Standard ANATEL mit Nr 00291-22-07318

### Resolução 680 – ATO 14448

Este equipamento não tem direito à proteção contra interferência prejudicial e não pode causar interferência em sistemas devidamente autorizados. Para maiores informações, consulte o site da ANATEL – [www.gov.br/anatel](http://www.gov.br/anatel).

### CISPR22

Este produto não é apropriado para uso em ambientes domésticos, pois poderá causar interferências eletro-magnéticas que obrigam o usuário a tomar medidas necessárias para minimizar estas interferências.



A0039064

## México

IFETEL

La operación de este equipo está sujeta a las siguientes dos condiciones:

- (1) Es posible que este equipo o dispositivo no cause interferencia perjudicial y
- (2) Este equipo o dispositivo debe aceptar cualquier interferencia, incluyendo la que pueda causar su operación no deseada.

## UAE

TRA REGISTERED No.: ER97368/21

## Qatar

Type Approval Reference: CRA/SM/2024/S-0016031

## Japan

電気通信事業法

Japanese Radio Law and Japanese Telecommunications Business Law Compliance.

This device is granted pursuant to the Japanese Radio Law (電波法) and the Japanese Telecommunications Business Law (電気通信事業法).

This device should not be modified (otherwise the granted designation number will become invalid).

## Thailand

เครื่องโทรคมนาคมและอุปกรณ์นี้ มีความสอดคล้องตามข้อกำหนดของ กสทช.

(This telecommunication equipment is in compliance with NBTC requirements.)



A0046301

(This radio communication equipment is exempted from requiring a license, user license, or radio communication station license as per NBTC notification regarding radio communication equipment and radio communication station has been exempted from requiring a license according to radio communication act B.E.2498.)

**Indonesia**

Cert. ID: 78107/SDPPI/2021  
 PLG ID: 4962



A0047307

**Singapore**



A0042672

**South Korea**

방송통신기자재등의 적합등록 필증  
 (Registration of Broadcasting and Communication Equipments)  
 기자재명칭 (제품명칭) : 특성소출력 무선기기 (무선데이터통신시스템용 무선기기)  
 (Equipment code: LARN8 Registration No.: R-R-EH7-SWA50)  
 해당 기자재는 「전파법」 제58조의2 제3항에 따라 등록되었습니다.  
 (It is verified that foregoing equipment has been registered under the Clause 3, Article 58-2 of Radio Waves Act.)

**Other radio approvals**

All available radio approvals can be found on the product page of the FieldPort SWA50 or in the Endress+Hauser downloads area.

Certificates and approvals: → 16



---



71656903

[www.addresses.endress.com](http://www.addresses.endress.com)

---