

Source container

The source holder for radiometric measurements in extreme applications.

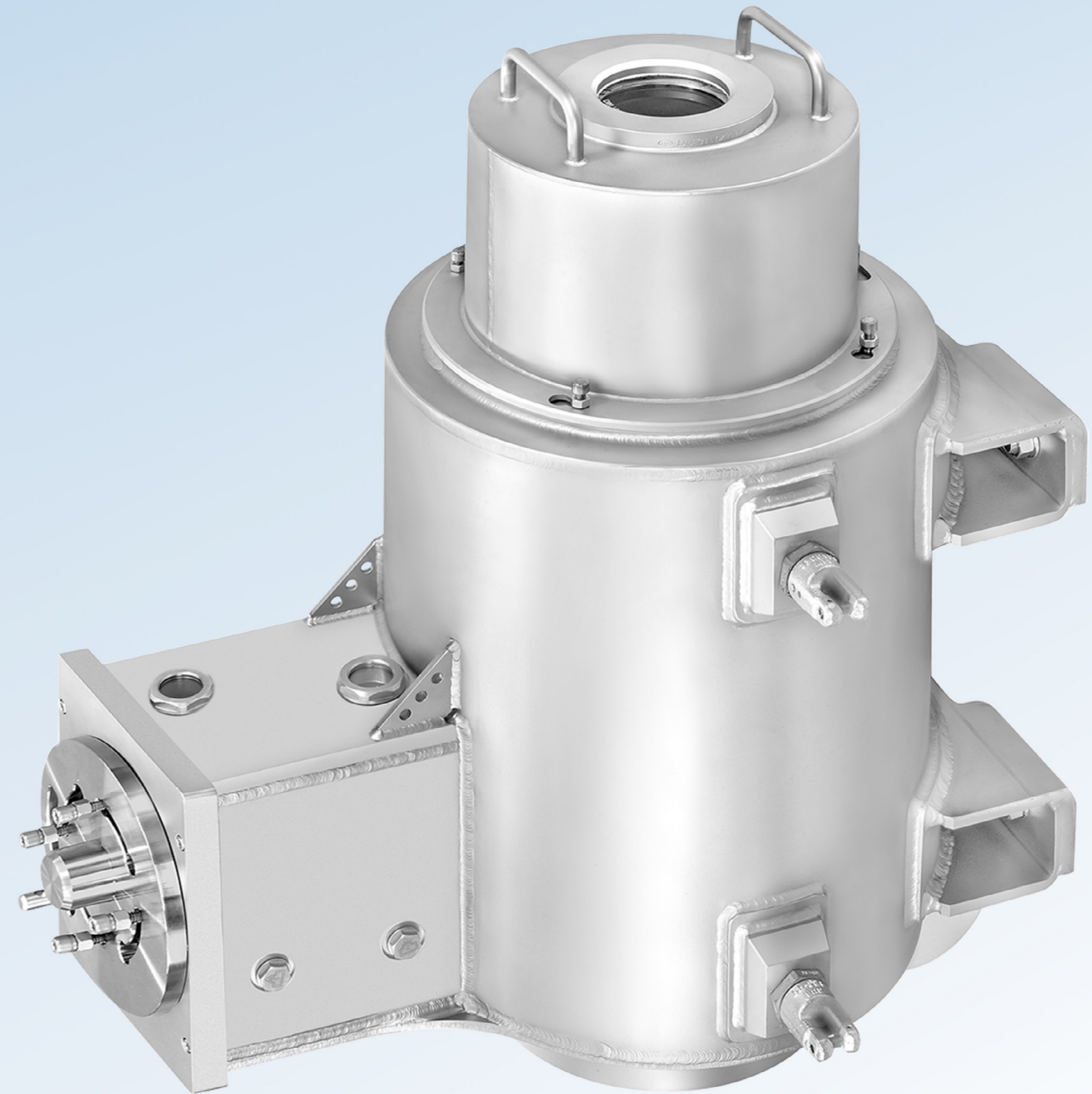

Source container FGQ74

The source container FQG74 is designed to reliably hold up to 20 internal radioactive sources with highest activities during radiometric measurements. It is easy to use in straight and bent dip tube designs and provides the highest radiation safety thanks to robust and high shielding. The source container FQG74 meets the design requirements of IEC 62598 and is used in combination with a radiometric transmitter for point level detection, continuous level and multipoint density measurements. It is especially suitable for applications with long measuring ranges.

Perfect fit:

In combination with the Gammapilot FMG50 multiple measuring tasks such as point level detection, continuous level and density measurement can be solved.

Simplified safety measures:

High shielding ensures no control areas are generally required and that installation in accessible areas is possible.

High safety level:

Best-in-class safety (Type A approval) and radiation protection.

High versatility:

Different variants tailored to individual application needs.

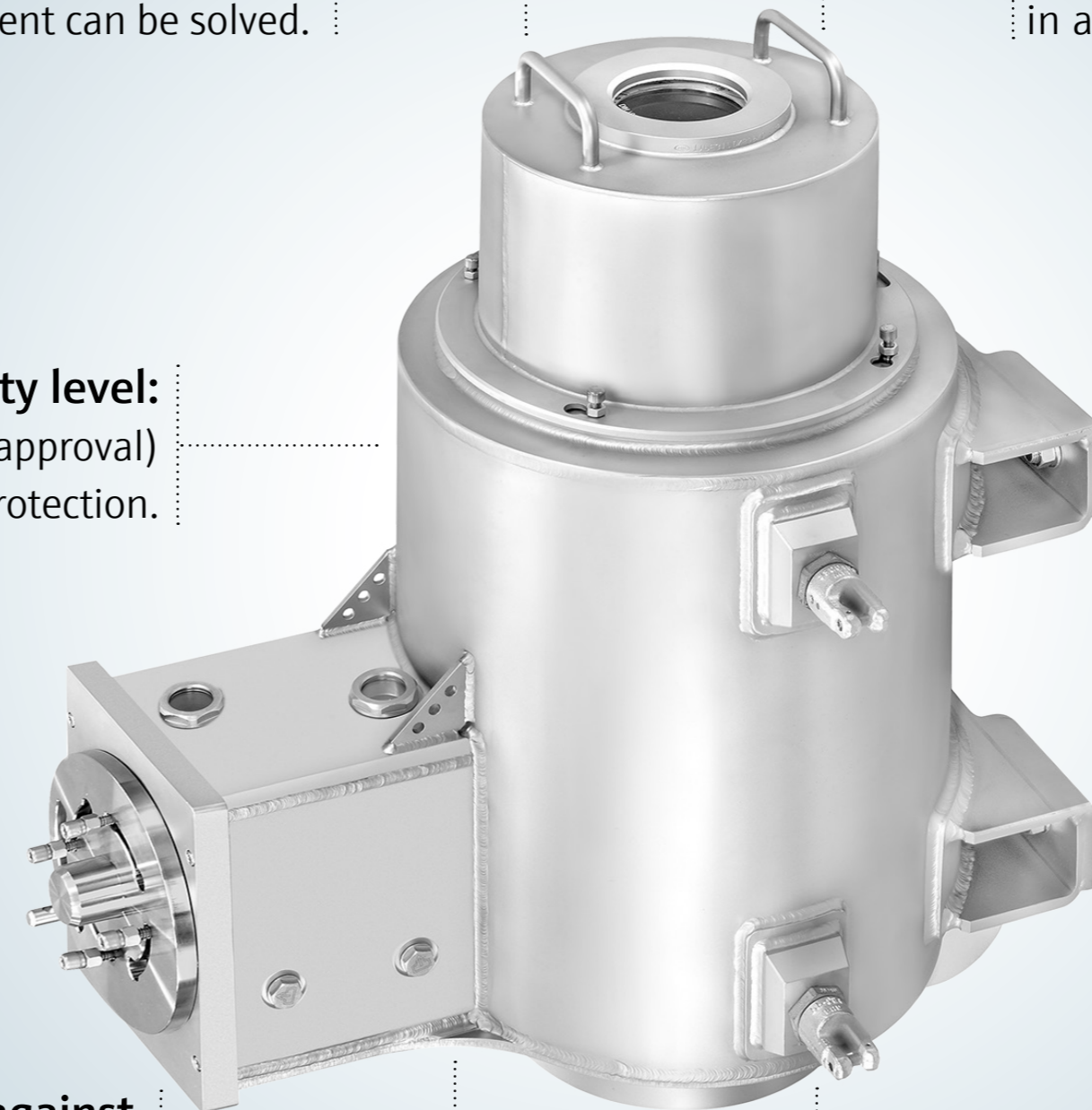

Protection against unauthorized use:

Padlock for fixation the on/off switch position and to protect against theft.

Easy commissioning:

The source position can be adjusted individually by independent ropes which can be extended up to 30 meters.

Optimal control, improved safety

Polymerisation and oxidation reactors are necessary in the chemical industry. These processes often pose challenges for measurement specialists as they come with extreme process and ambient conditions.

Reliable and accurate measurement is always possible with radiometric devices, regardless of conditions.

Level measurement to produce Purified Terephthalic Acid

Purified Terephthalic Acid (PTA) is an important raw material to produce PET bottles, polyester fibers and films. Production of PTA involves oxidation of raw materials which is carried out in a high-pressure oxidation reactor.

Your challenges

- Obstacles like agitators in the vessel
- Very high pressure in the vessel leading to thick walls
- Strong build-up at the vessel wall

Our solution

Multiple internal sources installed inside the dip tube reduce the influence of pressure change and build-up. With our radiometric detector Gammapilot FMG50 installed outside the vessel, a continuous and reliable level measurement is possible so plant operators are always in control of their processes.

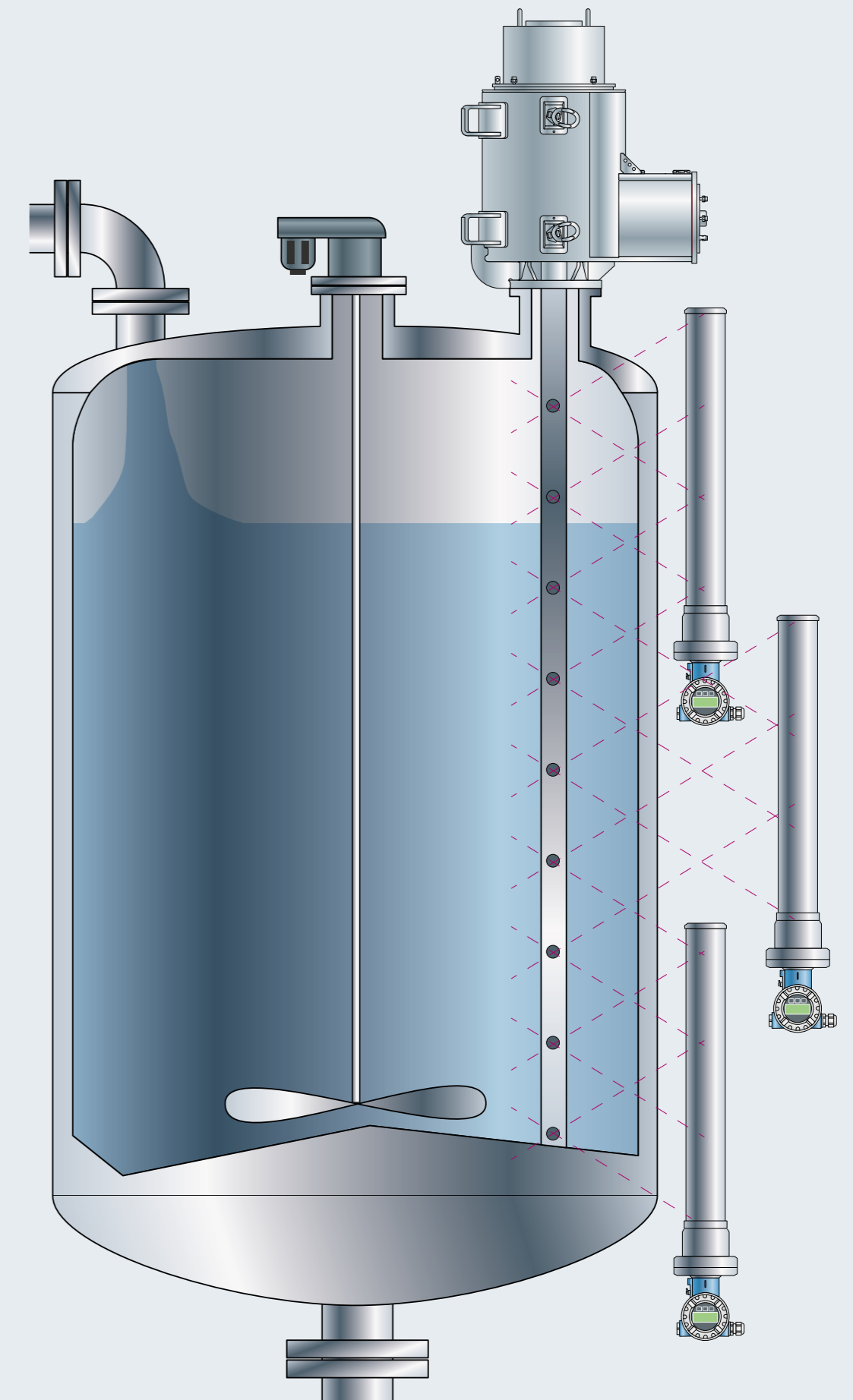

Enhanced efficiency, reduced operation costs

Accurate level and interface measurement is crucial in the oil and gas industry. It allows for the separation of oil from emulsions, water, sands, salts and other impurities.

Proper measurement ensures optimal separation processes. Precise detection minimizes the risk of equipment damage and improves product quality by preventing contamination and ensuring consistent oil output.

Density profile measurement in upstream processes

In oil and gas upstream processes, oil that is pumped from the earth must be separated from water, sand and other impurities. The first step of the separation process involves passing the oil through a test separator to detach it from the rest of the components as much as possible.

Your challenges

- Multi-phase process without distinct interfaces
- Oil-water emulsion layer
- Sand build-up

Our solution

The source container FGQ74 with several internal sources and the radiometric transmitter Gammapilot FMG50 provide a complete density profile of your process regardless of the number of layers. The accurate phase controlling ensures water-oil-emulsion is kept to a minimum and the quality of the oil that overflows the weir is monitored. This reduces effort for further separation processes. The complete profile also ensures the accurate monitoring of sand build-up in the vessel.

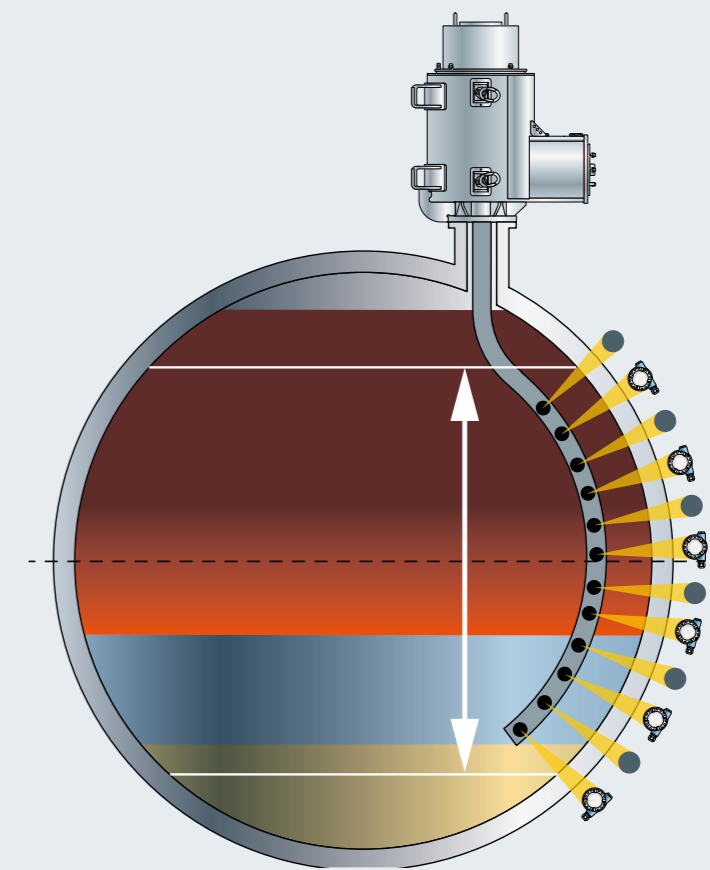
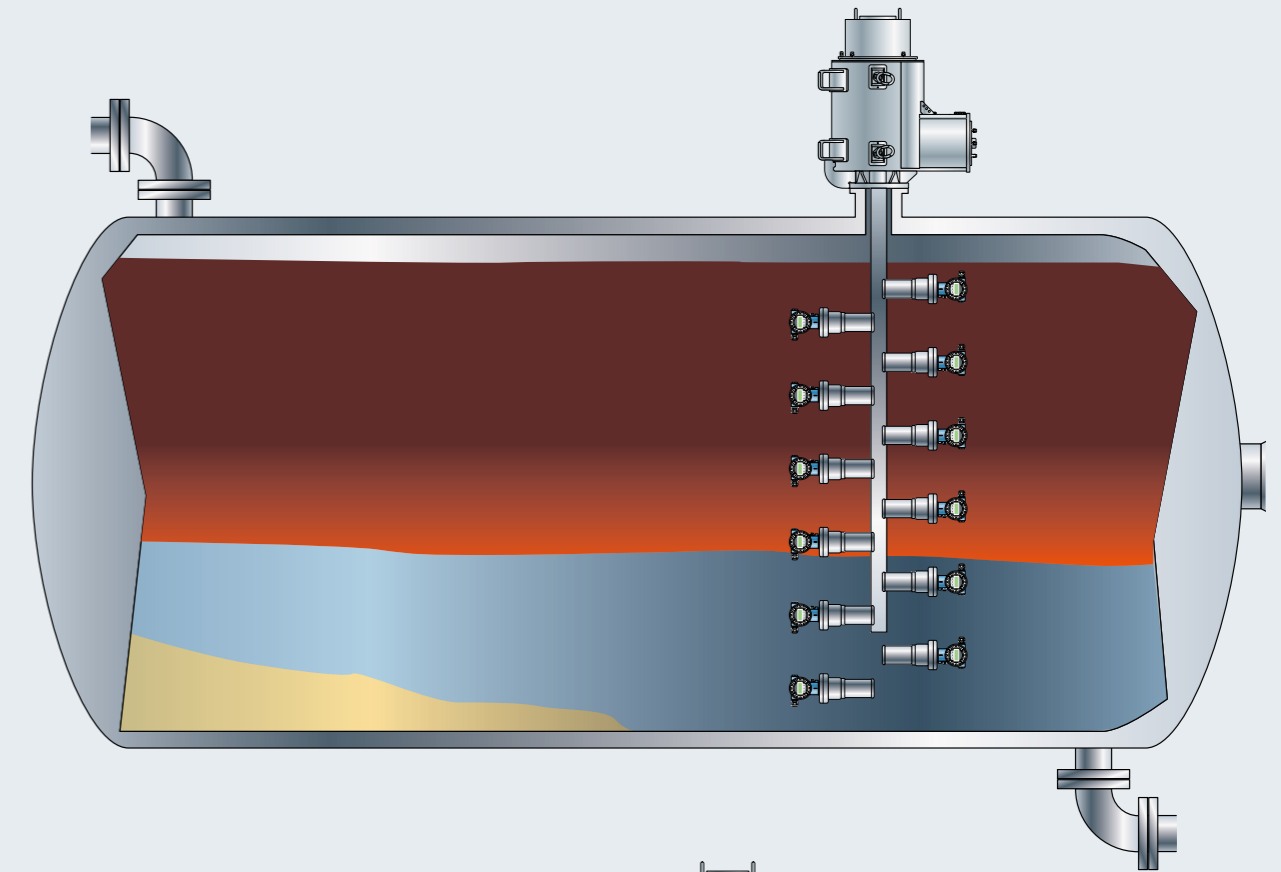

> One more thing

One more thing

The Gammapilot FMG50 is designed for non-contact point level detection, continuous level, interface and multipoint density measurement in liquids, solids, suspensions or sludges.

The detector can be used in extreme process conditions where other measuring principles reach their limits. As the first true 2-wire loop powered compact transmitter, it minimizes engineering and installation efforts. The device is developed in accordance with IEC 61508 for SIL2/3 and offers maximum plant safety, efficiency and availability. Heartbeat Technology allows for testing efforts and plant downtime to be reduced.

Thanks to a particularly high-quality sensor material, the Gammapilot FMG50 can operate up to 80°C (176°F) without additional cooling.



Visit us on social media

