



Brief Operating Instructions Micropilot FMR10B

Free-space radar



These Brief Operating Instructions are not a substitute for the Operating Instructions pertaining to the device. Detailed information can be found in the Operating Instructions and the additional documentation.

Available for all device versions via:

- Internet: www.endress.com/deviceviewer
- Smartphone/tablet: Endress+Hauser Operations app

Basic safety instructions

Manufacturer's address

Manufacturer: Endress+Hauser SE+Co. KG, Hauptstraße 1, D-79689 Maulburg or www.endress.com.

Place of manufacture: See nameplate.

Requirements for the personnel

The personnel must fulfill the following requirements to carry out their tasks, e. g. commissioning and maintenance:

- ▶ Trained specialists must have a qualification that is relevant to the specific function and task.
- ▶ Must be authorized by the plant owner/operator.
- ▶ Must be familiar with national regulations.
- ▶ Must have read and understood the instructions in the manual and supplementary documentation.
- ▶ Personnel must follow instructions and comply with general policies.

Intended use

Application and media

Device for continuous, non-contact level measurement of liquids, pastes, sludges and solids. Due to its operating frequency of approx. 80 GHz, a maximum radiated peak power of <math><1.5\text{ mW}</math> and an average output power of <math><70\text{ }\mu\text{W}</math>, unrestricted use outside of closed, metallic vessels is also permitted (for example over basins or open channels). Operation is completely harmless to humans and animals.

If the limit values specified in the "Technical data" and the conditions listed in the instructions and additional documentation are observed, the measuring instrument may be used only for the following measurements:

- ▶ Measured process variables: level, distance, signal strength

- ▶ Calculated process variables: volume or mass in vessels of any shape; flow rate through measuring weirs or channels (calculated based on the level using the linearization functionality)

To ensure that the device remains in proper condition for the operation time:

- ▶ Use the device only for media to which the process-wetted materials are sufficiently resistant.
- ▶ Observe the limit values in the "Technical data".

Workplace safety

When working on and with the device:

- ▶ Wear the required personal protective equipment as per national regulations.

Operational safety

- ▶ Operate the device only if it is in proper technical condition, free from errors and faults.
- ▶ The operator is responsible for ensuring that the device is in good working order.

Product safety

This product is designed in accordance with good engineering practice to meet state-of-the-art safety requirements and has been tested and left the factory in a condition in which it is safe to operate.

Mounting

Mounting instructions



When installing:

The sealing element used must have a continuous operating temperature corresponding to the maximum process temperature.

- Devices are suitable for use in wet environments in accordance with IEC/EN 61010-1
- Protect the housing against impact

Mounting requirements



Please note the following:

- The sensor cables are not designed as supporting cables. Do not use them for suspension purposes.

- For rope mounting, the rope must be provided by the customer.
- Always operate the device in a vertical position in free-space applications.

Ambient temperature range

-40 to +60 °C (-40 to +140 °F)

If operating outdoors in strong sunlight:

- Mount the device in a shaded location
- Avoid direct sunlight, particularly in warmer climatic regions
- Use a protective cover

Process temperature range

-40 to +60 °C (-40 to +140 °F)

Process pressure range, 40 mm (1.5 in) antenna

- $p_{\text{gauge}} = -1$ to 3 bar (-14.5 to 43.5 psi)
- $p_{\text{abs}} < 4$ bar (58 psi)

i The pressure range may be further restricted in the case of a CRN approval.

Mounting location

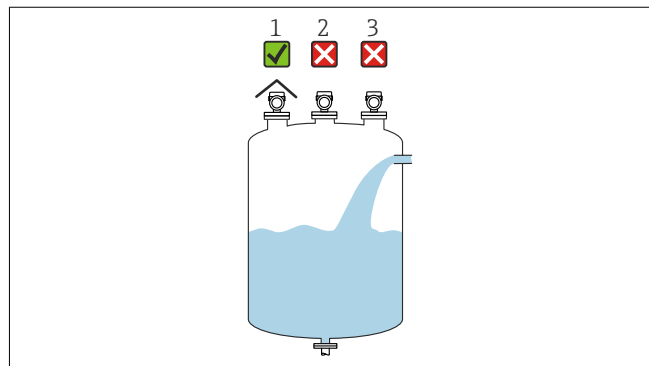

- 1 Use of a weather protection cover; protection from direct sunlight or rain
- 2 Installation not centered: Interferences can lead to incorrect signal analysis
- 3 Do not install above the filling curtain

Installation types

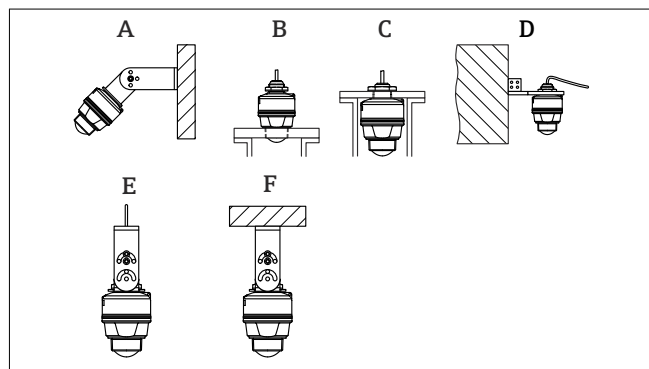

1 Wall or ceiling mount

- A Wall mounting adjustable
- B Tightened at antenna end process connection
- C Tightened at cable entry process connection
- D Wall mounting with cable entry process connection
- E Rope mounting
- F Ceiling installation

Installation instructions

To ensure optimum measurement, the antenna must protrude from the nozzle. The interior of the nozzle must be smooth and must not contain any edges or welded joints. If possible, round the nozzle edge.

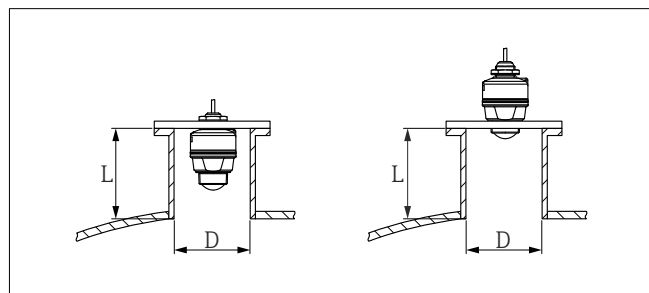

2 Nozzle installation, 40 mm (1,5 in) antenna

The maximum nozzle length L depends on the nozzle diameter D .

Please note the limits for the diameter and length of the nozzle.

40 mm (1.5 in) antenna, installation outside nozzle

- D : min. 40 mm (1.5 in)
- L : max. $(D - 30 \text{ mm (1.2 in)}) \times 7.5$

40 mm (1.5 in) antenna, installation inside nozzle

- D : min. 80 mm (3 in)
- L : max. $100 \text{ mm (3.94 in)} + (D - 30 \text{ mm (1.2 in)}) \times 7.5$

Electrical connection

Cable assignment

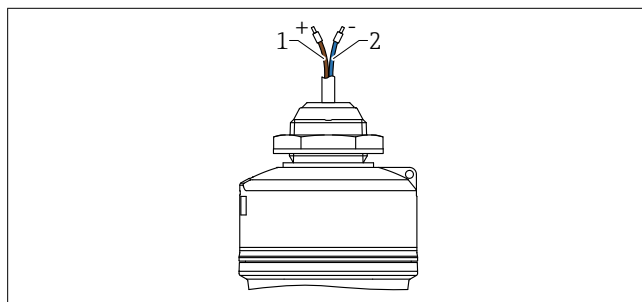

3 Cable assignment, cable entry from above

- 1 Plus, brown wire
- 2 Minus, blue wire

Supply voltage

12 to 30 V_{DC} on a direct current power unit

i The power unit must be safety-approved (e.g. PELV, SELV, Class 2) and must comply with the relevant protocol specifications.

Protective circuits against reverse polarity, HF influences and overvoltage peaks are installed.

Power consumption

To meet device safety specifications according to the IEC/EN 61010 standard, the installation must ensure that the maximum current is limited to 500 mA.

Overvoltage protection

The device satisfies the IEC/DIN EN 61326-1 product standard (Table 2 Industrial environment). Depending on the type of connection (DC power supply, input line, output line), different test levels are used to prevent transient overvoltages (IEC/DIN EN 61000-4-5 Surge) in accordance with IEC/DIN EN 61326-1: Test level for DC power supply lines and IO lines: 1 000 V wire to ground.

Overvoltage category

In accordance with IEC/DIN EN 61010-1, the device is intended for use in networks with overvoltage protection category II.

Ensuring the degree of protection

Test as per IEC 60529 Edition 2.2 2013-08/DIN EN 60529 2014-09 and NEMA 250-2014:

- IP66, NEMA Type 4X
- IP68, NEMA Type 6P (24 h at 1.83 m (6.00 ft) under water)