

Technical Information

Liquiphant FTL43

HART

Vibronic



Point level switch for liquids

Application

- Point level switch for all pumpable liquids, for minimum or maximum detection in vessels, e.g. process tanks, storage tanks, and piping, even in hazardous areas
- Process temperature range: -40 to +150 °C (-40 to +302 °F)
- Pressures up to 64 bar (928 psi)
- Viscosities up to 10 000 mPa·s
- Ideal substitute for float switches as reliable function is not affected by flow, turbulence, air bubbles, foam, vibration, solids content or buildup.

Advantages

- Easy commissioning with plug and play functionality
- Certified, hygienic design (3-A, EHEDG, ASME BPE)
- Proven conformity with materials standards, e.g. EC1935/2004, FDA, GB 4806, cGMP
- Heartbeat Technology for predictive and preventive maintenance
- Bluetooth® wireless technology for commissioning, operation and maintenance
- CIP and SIP capabilities - up to protection class IP69











Table of contents

About this document	4	Operating height	16
Symbols	4	Climate class	16
List of abbreviations	4	Degree of protection	16
Graphic conventions	5	Pollution degree	16
		Vibration resistance	16
Function and system design	5	Shock resistance	16
Measuring principle	5	Electromagnetic compatibility (EMC)	16
Measuring system	5		
Communication and data processing	5	Process	16
Reliability	5	Process temperature range	16
Device-specific IT security	6	Thermal shock	17
		Process pressure range	17
Input	6	Test pressure	17
Measured variable	6	Density	17
Measuring range	6	Viscosity	17
		Pressure tightness	17
Output	6	Solids contents	17
Output signal	6		
Signal on alarm for devices with current output	6	Mechanical construction	17
Load	6	Design, dimensions	17
Damping	7	Dimensions	18
Switch output	7	Weight	20
Ex connection data	7	Materials	20
Protocol-specific data	7	Process connections	20
		Surface roughness	26
Power supply	8		
Terminal assignment	8	Display and user interface	26
Available device plugs	8	Operation concept	26
Supply voltage	9	LED indicator	27
Power consumption	9	Remote operation	28
Potential equalization	9	System integration	28
Overvoltage protection	9	Supported operating tools	28
Performance characteristics	9	Certificates and approvals	28
Reference operating conditions	9	Hygienic design requirements	29
Response time	9	Compliance with requirements derived from cGMP	29
Take switch point into consideration	9	TSE (BSE) compliance (ADI free - Animal Derived Ingredients)	29
Resolution	10	Industry Canada	29
Maximum measured error	10	ASME BPE	29
Hysteresis	10		
Non-repeatability	10	Ordering information	29
Influence of the process temperature	10	Identification	29
Influence of the process pressure	10		
Influence of the process medium density (at room temperature and normal pressure)	10	Application packages	30
Response time	11	Heartbeat Technology	30
Warm-up time (according to IEC 62828-4)	11	"Medium detection" operating mode	30
Mounting	11	Accessories	31
Orientation	11	Device-specific accessories	31
Installation instructions	11	DeviceCare SFE100	32
Installing the device in piping	14	FieldCare SFE500	32
Special mounting instructions	14	Device Viewer	32
		Field Xpert SMT70	32
Environment	15	Field Xpert SMT77	32
Ambient temperature range	15	SmartBlue app	32
Storage temperature	16		

Documentation 32
Standard documentation 32
Supplementary device-dependent documentation 33

Registered trademarks 33

About this document

Symbols	<p>Safety symbols</p> <p> DANGER This symbol alerts you to a dangerous situation. Failure to avoid this situation will result in serious or fatal injury.</p> <p> WARNING This symbol alerts you to a dangerous situation. Failure to avoid this situation can result in serious or fatal injury.</p> <p> CAUTION This symbol alerts you to a dangerous situation. Failure to avoid this situation can result in minor or medium injury.</p> <p>NOTICE This symbol contains information on procedures and other facts which do not result in personal injury.</p> <p>Tool symbols</p> <p> Open-ended wrench</p> <p>Communication-specific symbols</p> <p>Bluetooth®:  Wireless data transmission between devices over a short distance</p> <p>Symbols for certain types of information</p> <p><i>Permitted:</i>  Procedures, processes or actions that are permitted.</p> <p><i>Forbidden:</i>  Procedures, processes or actions that are forbidden.</p> <p><i>Additional information:</i> </p> <p><i>Reference to documentation:</i> </p> <p><i>Reference to page:</i> </p> <p><i>Series of steps:</i> 1., 2., 3.</p> <p><i>Result of an individual step:</i> </p> <p>Symbols in graphics</p> <p><i>Item numbers:</i> 1, 2, 3 ...</p> <p><i>Series of steps:</i> 1., 2., 3.</p> <p><i>Views:</i> A, B, C, ...</p>
List of abbreviations	<p>PN Nominal pressure</p> <p>MWP Maximum working pressure The maximum working pressure is indicated on the nameplate.</p> <p>DTM Device Type Manager</p> <p>Operating tool</p>

The term "operating tool" is used in place of the following operating software:

- FieldCare / DeviceCare, for operation via HART communication and PC
- SmartBlue app, for operation using an Android or iOS smartphone or tablet

PLC

Programmable logic controller (PLC)

Graphic conventions



- Installation, explosion and electrical connection drawings are presented in simplified format
- Devices, assemblies, components and dimensional drawings are presented in reduced-line format
- Dimensional drawings are not to-scale representations; the dimensions indicated are rounded off to 2 decimal places
- Unless otherwise described, flanges are presented with sealing surface form EN 1092-1; ASME B16.5, RF.

Function and system design

Measuring principle

The sensor's tuning fork vibrates at its intrinsic frequency. As soon as the liquid covers the tuning fork, the vibration frequency decreases. The change in frequency causes the point level switch to switch.

Point level detection

Maximum or minimum detection for liquids in tanks or pipes in all industries. Suitable for leakage monitoring, pump dry-running protection or overflow prevention, for example.

Specific versions are suitable for use in hazardous areas.

The point level switch differentiates between the "covered" and "not covered" conditions.

Depending on the MIN (minimum detection) or MAX (maximum detection) modes, there are two possibilities in each case: OK status and demand mode.

OK status

- In MIN mode, the fork is covered, e.g. pump dry-running protection
- In MAX mode, the fork is not covered, e.g. overflow prevention

Demand mode

- In MIN mode, the fork is not covered, e.g. pump dry-running protection
- In MAX mode, the fork is covered, e.g. overflow prevention

Measuring system

A complete measuring system comprises:

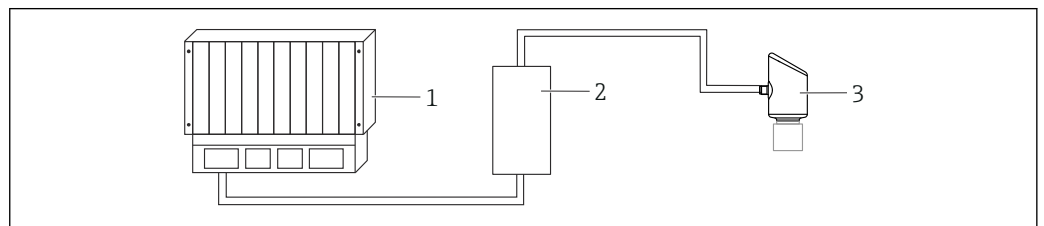

A0053220

- 1 PLC (programmable logic controller)
- 2 RMA42/RIA45 (if necessary)
- 3 Device

Communication and data processing

- 4 to 20 mA with superimposed digital communication protocol HART, 2-wire
- Bluetooth (optional)

Reliability

IT security

Our warranty is valid only if the product is installed and used as described in the Operating Instructions. The product is equipped with security mechanisms to protect it against any inadvertent changes to the settings.

IT security measures, which provide additional protection for the product and associated data transfer, must be implemented by the operators themselves in line with their security standards.

Device-specific IT security The device offers specific functions to support protective measures by the operator. These functions can be configured by the user and guarantee greater in-operation safety if used correctly. The user role can be changed with an access code (applies to operation via Bluetooth or FieldCare, DeviceCare or asset management tools (e.g. AMS, PDM).

Access via Bluetooth® wireless technology

Secure signal transmission via Bluetooth® wireless technology uses an encryption method tested by the Fraunhofer Institute.

- Without the SmartBlue app, the device is not visible via Bluetooth® wireless technology.
- Only one point-to-point connection is established between the device and a smartphone or tablet.
- The Bluetooth® wireless technology interface can be disabled via local operation or via SmartBlue.

Input

Measured variable Level (point level), MAX or MIN safety

Measuring range Depends on the installation location and the pipe extension ordered
Maximum sensor length 1.5 m (5 ft)

Output

Output signal **SIO**
8/16 mA (SIO) with superimposed digital communication protocol HART, 2-wire

Continuous operation

4 to 20 mA proportional to the oscillation frequency with superimposed digital communication protocol HART, 2-wire

The current output offers a choice of three different operating modes:

- 4.0 to 20.5 mA
- NAMUR NE 43: 3.8 to 20.5 mA (factory setting)
- US mode: 3.9 to 20.5 mA

Signal on alarm for devices with current output **Current output**
Signal on alarm in accordance with NAMUR recommendation NE 43.

- Max. alarm: can be set from 21.5 to 23 mA
- Min. alarm: < 3.6 mA (factory setting)

Load In order to guarantee sufficient terminal voltage, a maximum load resistance R_L (including line resistance) must not be exceeded, depending on the supply voltage U of the supply unit.

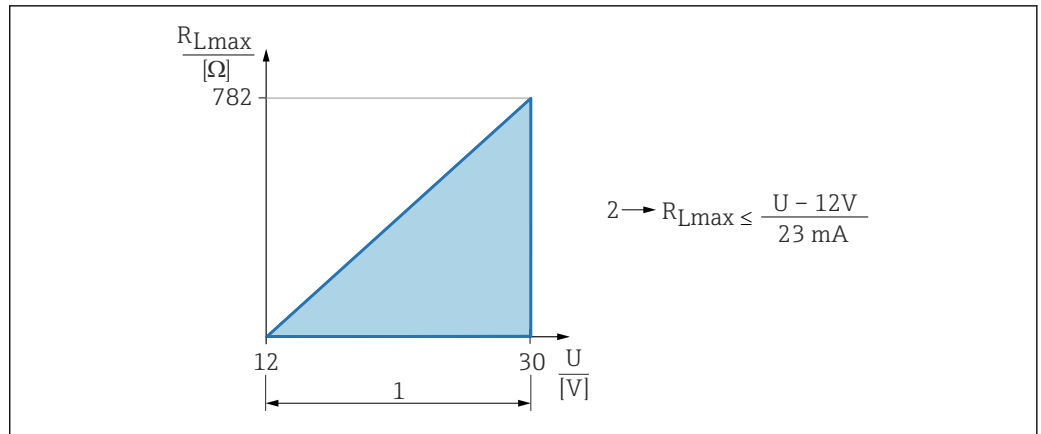

- 1 Power supply 12 to 30 V
 2 R_{Lmax} maximum load resistance
 U Supply voltage

i Operation via handheld terminal or PC with operating program: take minimum communication resistance of 250 Ω into consideration.

Damping

A damping affects all continuous outputs.
 Factory setting: 1 s (can be configured from 0 to 999 s)

Switch output

Preset switching delay times can be ordered:

- 0.5 s when the tuning fork is covered and 1.0 s when the tuning fork is uncovered (factory setting)
- 0.25 s when the tuning fork is covered and 0.25 s when the tuning fork is uncovered
- 1.5 s when the tuning fork is covered and 1.5 s when the tuning fork is uncovered
- 5.0 s when the tuning fork is covered and 5.0 s when the tuning fork is uncovered

i The user can also set the switching delays for when the fork is covered and uncovered in the range from 1 to 60 seconds independently of one another.

(Operation via Bluetooth or FieldCare, DeviceCare)

Ex connection data

i See the separate technical documentation (Safety Instructions (XA)) on www.endress.com/download.

Protocol-specific data

Manufacturer ID:

17(0x0011)

Device type ID:

0x11DF

Device revision:

1

HART specification:

7.6

DD version:

1

Device description files (DTM, DD)

Information and files available at:

- www.endress.com
 On the product page for the device: Documents/Software → Device drivers
- www.fieldcommgroup.org

HART load:

Min. 250 Ω

The following measured values are assigned to the device variables at the factory:

Device variable	Measured value
Primary variable (PV) ¹⁾	Level limit detection ²⁾
Secondary variable (SV)	Sensor frequency ³⁾
Tertiary variable (TV)	Fork state ⁴⁾
Quaternary variable (QV)	Sensor temperature

- 1) The PV is always applied to the current output.
- 2) Level limit detection is the initial state depending on the fork state (uncovered/covered) and the safety function (MIN/MAX)
- 3) Sensor frequency is the oscillation frequency of the fork
- 4) Fork state describes the fork state (Fork covered/Fork uncovered)

Choice of HART device variables

- Level limit detection
- Sensor frequency
- Fork state
- Sensor temperature
- Electronics temperature
- Measured current ¹⁾
- Terminal voltage ¹⁾
- Not used

Power supply

Terminal assignment

2-wire

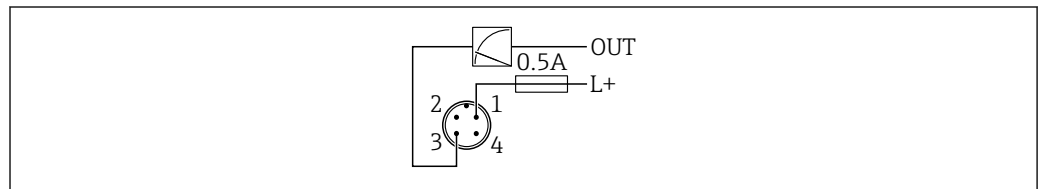

A0052662

- 1 Supply voltage L+, brown wire (BN)
- 3 OUT (L-), blue wire (BU)

Available device plugs

M12 plug

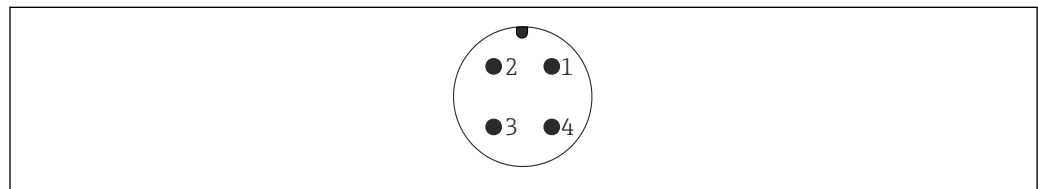

A0052661

 1 View of the connection on the device

 For further information, see the "Device-specific accessories" section

1) Visible depending on the order options or device settings

Supply voltage	<p>12 to 30 V_{DC} on a direct current power unit</p> <p> The power unit must be tested to ensure it meets safety requirements (e.g. PELV, SELV, Class 2) and must comply with the relevant protocol specifications.</p> <p>For 4 to 20 mA the same requirements apply as for HART. A galvanically isolated active barrier must be used for devices approved for use in explosion hazardous areas.</p> <p>A suitable circuit breaker should be provided for the device in accordance with IEC/EN 61010-1.</p> <p>Protective circuits against reverse polarity, HF influences and overvoltage peaks are installed.</p>
Power consumption	<ul style="list-style-type: none"> ▪ Non-hazardous area: To meet device safety specifications according to the IEC/EN 61010 standard, the installation must ensure that the maximum current is limited to 500 mA. ▪ Hazardous area: The maximum current is restricted to $I_i = 100$ mA by the transmitter power supply unit when the measuring instrument is used in an intrinsically safe circuit (Ex ia).
Potential equalization	<p>If necessary, establish potential equalization using the process connection or the grounding clamp supplied by the customer.</p>
Overvoltage protection	<p>The device satisfies the IEC/DIN EN 61326-1 product standard (Table 2 Industrial environment). Depending on the type of connection (DC supply, input/output line) different test levels according to IEC/DIN EN 61326-1 against transient overvoltages are applied (IEC/DIN EN 61000-4-5 Surge): test level for DC power supply lines and input/output lines: 1 000 V line to earth.</p> <p>Overvoltage protection category</p> <p>In accordance with IEC/DIN EN 61010-1, the device is intended for use in networks with overvoltage protection category II.</p>

Performance characteristics

Reference operating conditions	<ul style="list-style-type: none"> ▪ As per IEC 62828-2 ▪ Ambient temperature: +23 °C (+73 °F) ▪ Process temperature: +23 °C (+73 °F) ▪ Humidity ϕ = constant, in range: 5 to 80 % rF \pm 5 % ▪ Medium density (water): 1 g/cm³ (62.4 lb/ft³) ▪ Medium viscosity: 1 mPa·s ▪ Atmospheric pressure p_U = constant, in range: 860 to 1 060 mbar (12.47 to 15.37 psi) ▪ Process pressure: atmospheric pressure/unpressurized ▪ Sensor installation: vertically from above ▪ Switch direction of sensor: uncovered to covered ▪ Load with HART: 250 Ω ▪ Supply voltage: 24 V DC \pm3 V DC
Response time	<ul style="list-style-type: none"> ▪ HART: acyclic: min. 330 ms, typically 590 ms (depending on commands and number of preambles) ▪ HART: Cyclic (burst): min. 160 ms, typically 350 ms (depending on commands and number of preambles)
Take switch point into consideration	<p>The following are typical switch points, depending on the orientation of the point level switch.</p> <p>Water +23 °C (+73 °F)</p> <p> Minimum distance between the tuning fork and the tank wall or pipe wall: 10 mm (0.39 in)</p>

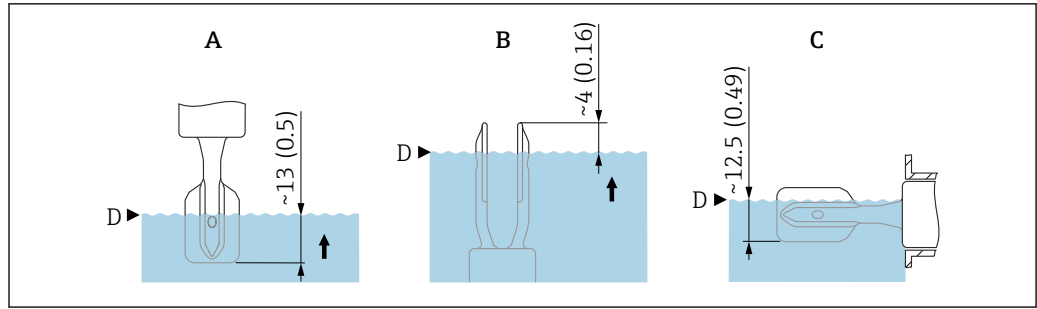

2 Typical switch points. Unit of measurement mm (in)

- A Installation from above
- B Installation from below
- C Installation from the side
- D Switch point

Resolution	Current output: < 1 μA
Maximum measured error	At reference operating conditions: max. ± 1 mm (0.04 in) at switch point
Hysteresis	Typically 2.5 mm (0.1 in)
Non-repeatability	0.5 mm (0.02 in)
Influence of the process temperature	The switch point moves from +1.4 to -2.6 mm (+0.06 to -0.1 in) in the temperature range of -50 to +150 $^{\circ}\text{C}$ (-58 to +302 $^{\circ}\text{F}$)
Influence of the process pressure	The switch point moves from 0 to 2.6 mm (0 to 0.1 in) in the pressure range of -1 to +64 bar (-14.5 to +928 psi)

Influence of the process medium density (at room temperature and normal pressure)

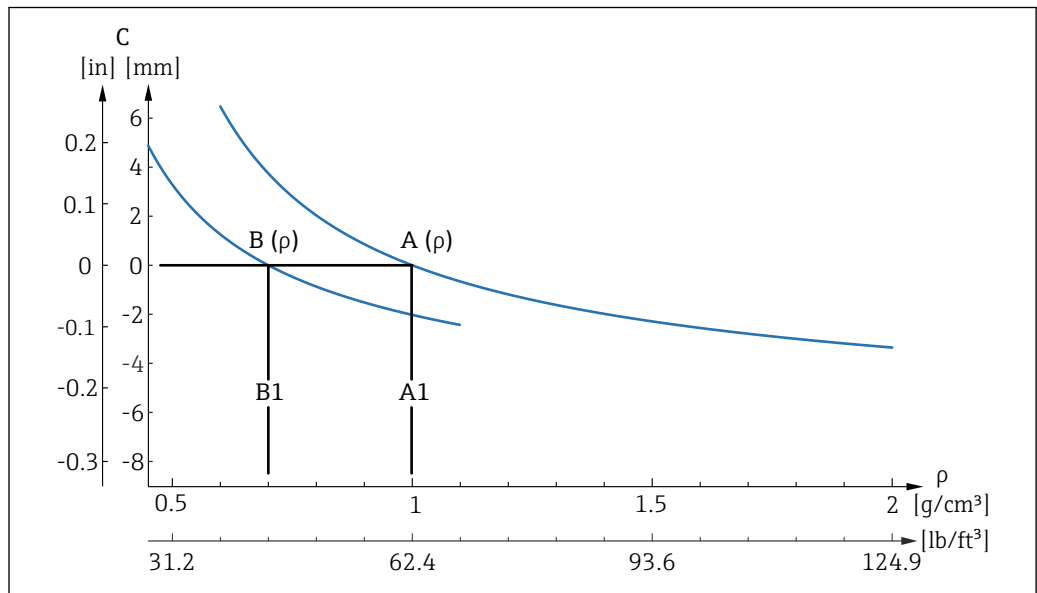

3 Switch point deviation over density

- A Setting (ρ) > 0.7 g/cm^3 (43.7 lb/ft^3)
- A1 Reference operating condition $\rho = 1$ g/cm^3 (62.4 lb/ft^3)
- B Setting (ρ) > 0.5 g/cm^3 (31.21 lb/ft^3)
- B1 Reference operating condition $\rho = 0.7$ g/cm^3 (43.7 lb/ft^3)
- C Switch point deviation

Density setting

- $TC_{typ.}$ [mm/10 k]
 - $\rho > 0.7 \text{ g/cm}^3$ (43.7 lb/ft³): -0.2
 - $\rho > 0.5 \text{ g/cm}^3$ (31.21 lb/ft³): -0.2
- $Pressure_{typ.}$ [mm/10 bar]
 - $\rho > 0.7 \text{ g/cm}^3$ (43.7 lb/ft³): -0.3
 - $\rho > 0.5 \text{ g/cm}^3$ (31.21 lb/ft³): -0.4

Response time

Dynamic behavior, current output

- Dead time (t_1): 3.5 ms maximum
- Time constant T63 (t_2): 30 ms maximum
- Time constant T90 (t_3): 65 ms maximum

Warm-up time (according to IEC 62828-4)

The warm-up time indicates the time the sensor requires to reach its maximum accuracy or performance after the supply voltage is applied

Warm-up time: $\leq 10 \text{ s}$

Mounting

Orientation

- Any orientation for compact version or version with a tube length up to approx. 500 mm (19.7 in)
- Vertical orientation from above for device with long pipe
- Minimum distance between the tuning fork and the tank wall or pipe wall: 10 mm (0.39 in)

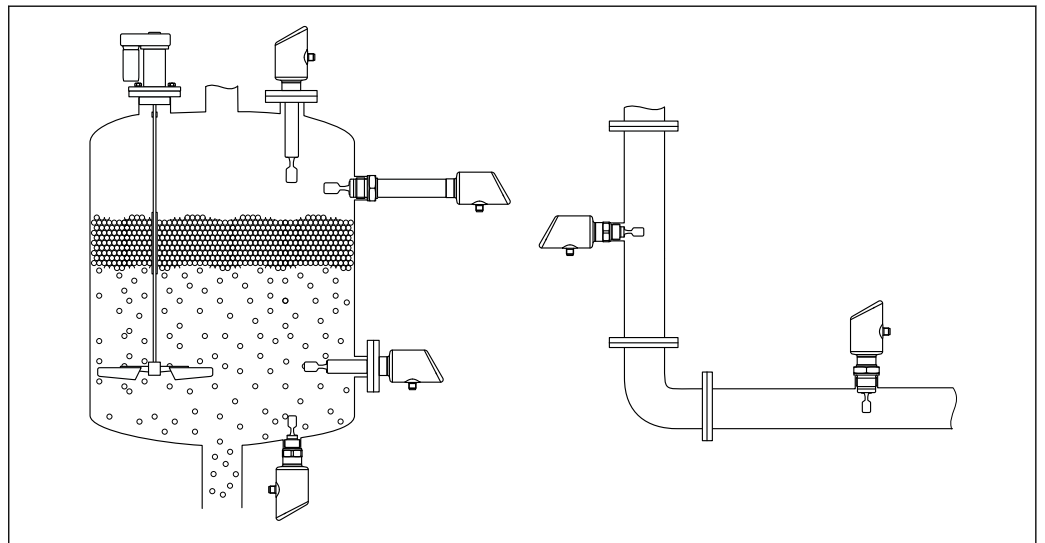

4 Installation examples for a vessel, tank or pipe

A0053113

Installation instructions

Mounting instructions

i During installation, it is important to ensure that the sealing element used has an operating temperature that corresponds to the maximum temperature of the process.

- Devices with CSA approval are intended for indoor use
- Devices are suitable for use in wet environments in accordance with IEC/EN 61010-1

Take viscosity into consideration

- i** Viscosity values
- Low viscosity: $< 2\,000 \text{ mPa}\cdot\text{s}$
 - High viscosity: $> 2\,000 \text{ to } 10\,000 \text{ mPa}\cdot\text{s}$

Low viscosity

i Low viscosity, e.g. water: $< 2\,000\text{ mPa}\cdot\text{s}$

It is permitted to position the tuning fork within the installation socket.

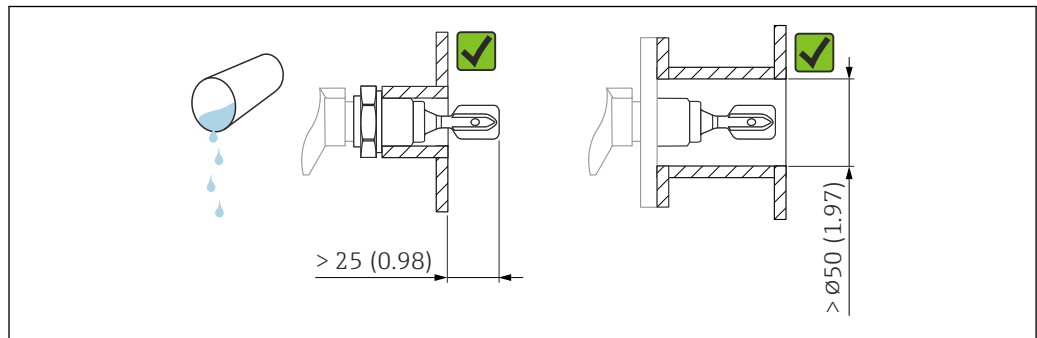

A0033297

5 Installation example for low-viscosity liquids. Unit of measurement mm (in)

*High viscosity***NOTICE**

Highly viscous liquids may cause switching delays.

- ▶ Make sure that the liquid can run off the tuning fork easily.
- ▶ Deburr the socket surface.

i High viscosity, e.g. viscous oils: $\leq 10\,000\text{ mPa}\cdot\text{s}$

The tuning fork must be located outside the installation socket!

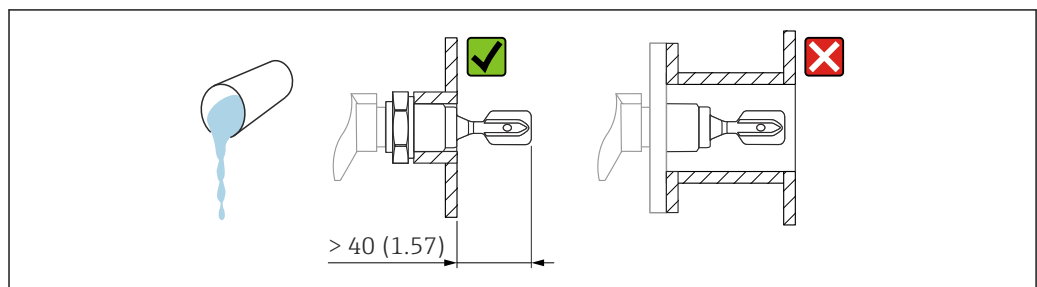

A0037348

6 Installation example for a highly viscous liquid. Unit of measurement mm (in)

Avoid buildup

- Use short installation sockets to ensure that the tuning fork projects freely into the vessel
- Leave sufficient distance between the buildup expected on the tank wall and the tuning fork

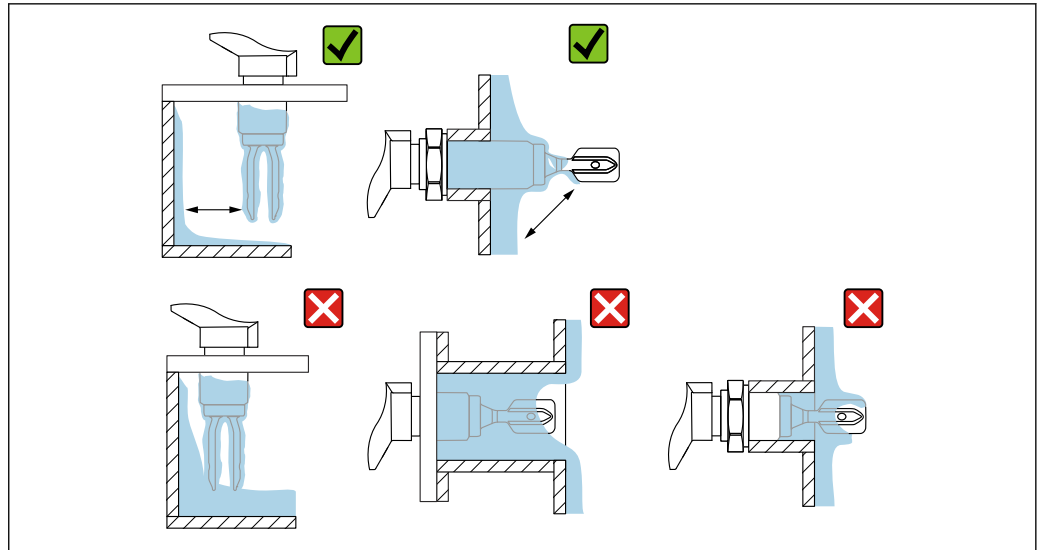

A0033239

7 Installation examples for a highly viscous process medium

Take clearance into consideration.

Allow sufficient clearance outside the tank for mounting and electrical connection.

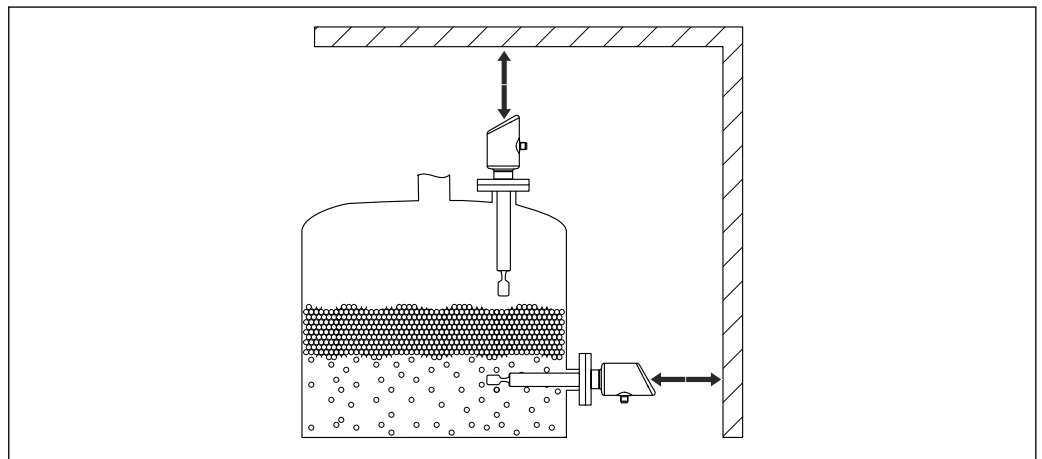

A0053359

8 Take clearance into consideration.

Aligning the tuning fork using the marking

The tuning fork can be aligned using the marking in such a way that the medium drains off easily and buildup is avoided.

Markings on process connection:

Material specification, thread designation, circle, line or double line

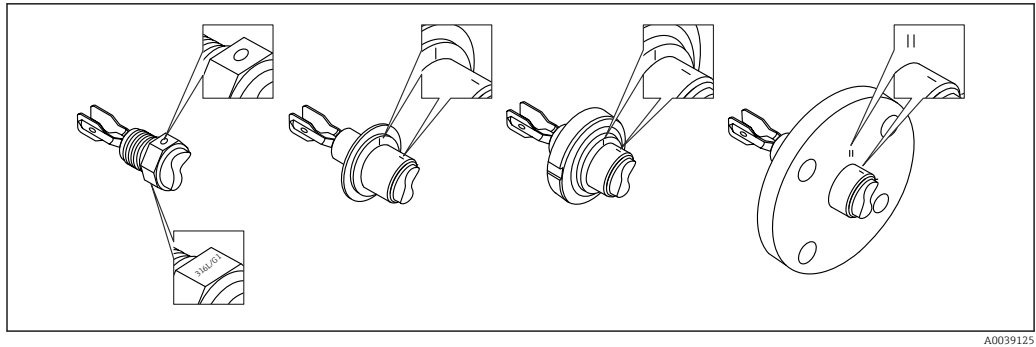

9 Position of the tuning fork when installed horizontally in the vessel using the marking

Installing the device in piping

- Flow velocity up to 5 m/s with a viscosity of 1 mPa·s and density of 1 g/cm³ (62.4 lb/ft³) (SGU). Check for correct functioning in the event of other process medium conditions.
- The flow will not be significantly impeded if the tuning fork is correctly aligned and the marking is pointing in the direction of flow.
- The marking is visible when installed.

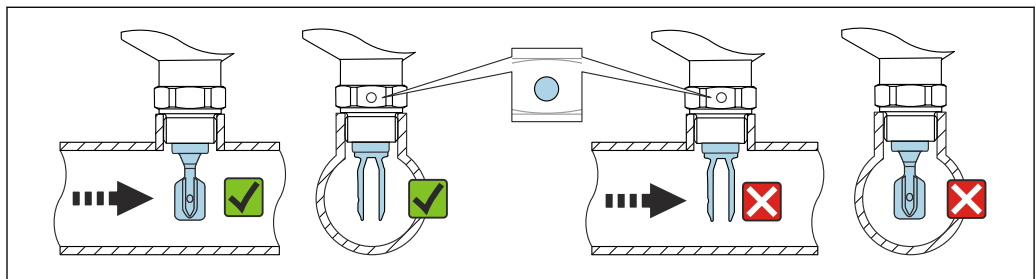

10 Installation in pipes (take fork position and marking into consideration)

Special mounting instructions

Vessel with heat insulation

If process temperatures are high, the device should be incorporated in the usual vessel insulation system to prevent the electronics from heating as a result of thermal radiation or convection. The insulation in this case should not be higher than the neck of the device.

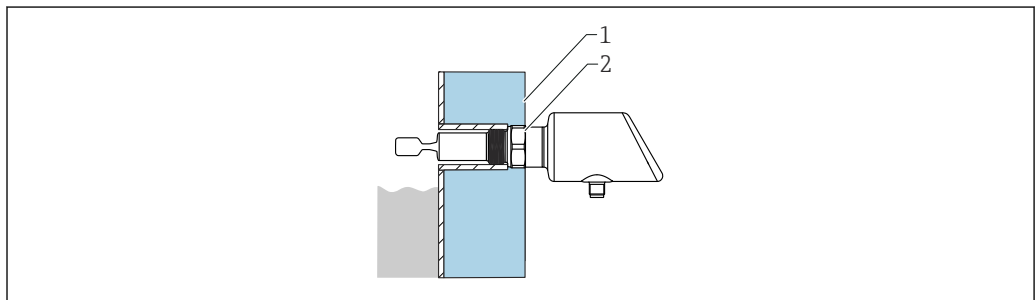

11 Vessel with heat insulation (example)

- Vessel insulation
- Insulation max. up to the housing neck

Support the device

Support the device in the event of severe dynamic load. Maximum lateral loading capacity of the pipe extensions and sensors: 75 Nm (55 lbf ft).

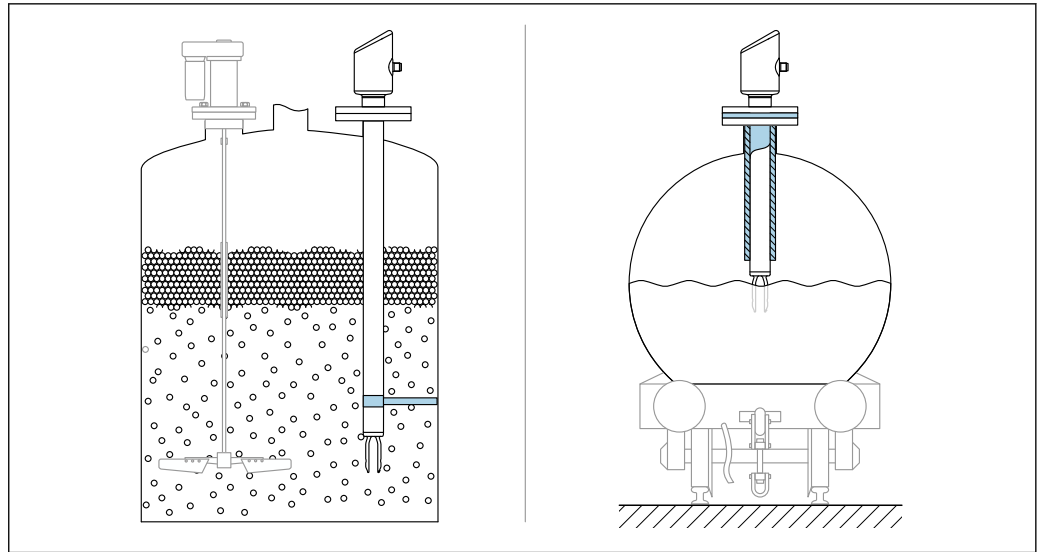

A0053109

12 Examples of support in the event of dynamic load

Weld-in adapter with leakage hole

Weld in the weld-in adapter in such a way that the leakage hole is pointing downwards. This enables any leaks to be detected quickly.

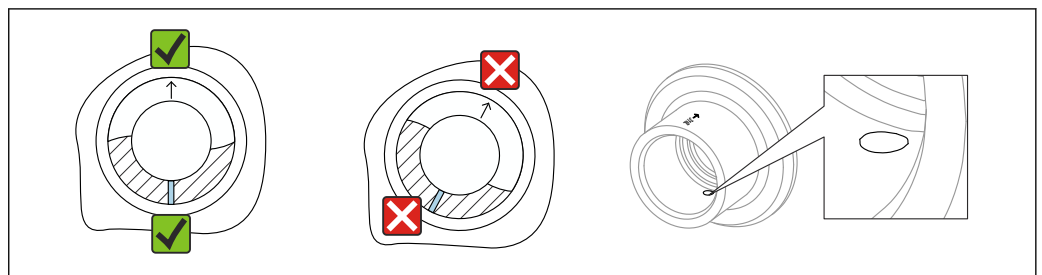

A0039230

13 Weld-in adapter with leakage hole

Environment

Ambient temperature range -40 to +85 °C (-40 to +185 °F)

The permitted ambient temperature is reduced at higher process temperatures.

i The following information only takes functional aspects into consideration. Additional restrictions may apply for certified device versions.

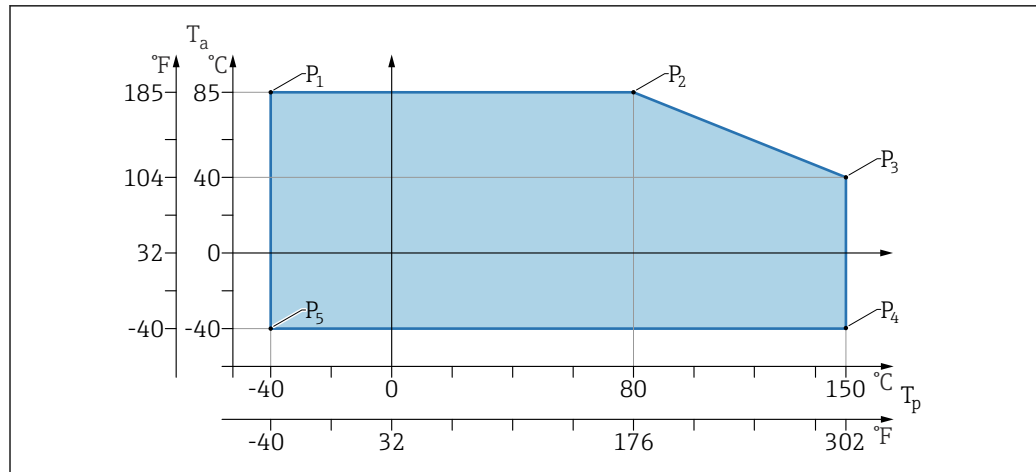

A0053280

14 Ambient temperature T_a depending on the process temperature T_p

P	T_p	T_a
P1	-40 °C (-40 °F)	+85 °C (+185 °F)
P2	+80 °C (+176 °F)	+85 °C (+185 °F)
P3	+150 °C (+302 °F)	+40 °C (+77 °F)
P4	+150 °C (+302 °F)	-40 °C (-40 °F)
P5	-40 °C (-40 °F)	-40 °C (-40 °F)

Storage temperature -40 to +85 °C (-40 to +185 °F)

Operating height Up to 5 000 m (16 404 ft) above sea level

Climate class According to IEC 60068-2-38 test Z/AD (relative humidity 4 to 100 %).

Degree of protection Test as per IEC 60529 Edition 2.2 2013-08/ DIN EN 60529:2014-09 DIN EN 60529:2014-09 and NEMA 250-2014
For mounted M12 connecting cable: IP66/68/69, NEMA type 4X/6P
/IP68; (1.83 mH₂O for 24 h))

Pollution degree Pollution degree 2 according to IEC/EN 61010-1

Vibration resistance

- Stochastic noise (random sweep) as per DIN EN 60068-2-64 Case 2/ IEC 60068-2-64 Case 2
- Guaranteed for 5 to 2 000 Hz: 1.25 (m/s²)²/Hz, ~ 5 g

Shock resistance

- Test standard: DIN EN 60068-2-27 Case 2
- Shock resistance: 30 g (18 ms) in all 3 axes

Electromagnetic compatibility (EMC)

- Electromagnetic compatibility as per EN 61326 series and NAMUR recommendation EMC (NE2.1)
- Maximum deviation under the effect of disturbance: < 0.5%

For more details refer to the EU Declaration of Conformity.

Process

Process temperature range -40 to +150 °C (-40 to +302 °F)

Pay attention to the pressure and temperature dependency.

Thermal shock ≤ 120 K/s

Process pressure range

Pressure specifications

⚠ WARNING

The maximum pressure for the device depends on the lowest-rated component with regard to pressure (components are: process connection, optional mounted parts or accessories).

- ▶ Only operate the device within the specified limits for the components!
- ▶ MWP (maximum working pressure): The MWP is specified on the nameplate. This value refers to a reference temperature of +20 °C (+68 °F) and may be applied to the device for an unlimited time. Note temperature dependence of MWP. For flanges, refer to the following standards for the permitted pressure values at higher temperatures: EN 1092-1 (with regard to their stability/temperature property, the materials 1.4435 and 1.4404 are grouped together under 13EO in EN 1092-1, Tab. 18; the chemical composition of the two materials can be identical) ASME B 16.5a, (the latest version of the standard applies in each case).
- ▶ The Pressure Equipment Directive (2014/68/EU) uses the abbreviation "PS". The abbreviation "PS" corresponds to the MWP (maximum working pressure) of the device.
- ▶ MWP data that deviate from this are provided in the relevant sections of the Technical Information.

Test pressure

- PN = 64 bar (928 psi): test pressure = $1.5 \cdot$ PN maximum 100 bar (1 450 psi) depending on the selected process connection
- Membrane burst pressure at 200 bar (2 900 psi)

The device function is limited during the pressure test.

Mechanical integrity is guaranteed up to 1.5 times the process nominal pressure PN.

Density

Liquids with density > 0.7 g/cm³ (43.7 lb/ft³)

Setting > 0.7 g/cm³ (43.7 lb/ft³), as supplied to the customer

Liquids with density 0.5 g/cm³ (31.2 lb/ft³)

Setting > 0.5 g/cm³ (31.2 lb/ft³), can be ordered as preset value or configurable

Liquids with density > 0.4 g/cm³ (25.0 lb/ft³)

Setting > 0.4 g/cm³ (25.0 lb/ft³), can be ordered as preset value or configurable

 For information on medium differentiation/density detection: Documentation Liquiphant density (FEL60D) with density computer FML621 (Endress+Hauser website www.endress.com → Downloads)

Viscosity

$\leq 10\,000$ mPa·s

Pressure tightness

Up to vacuum

 In vacuum evaporation plants, select the 0.4 g/cm³ (25.0 lb/ft³)/ density setting.

Solids contents

$\varnothing \leq 5$ mm (0.2 in)

Mechanical construction

Design, dimensions

Device height

The device height consists of the following components:

- Housing with electronics module
- Temperature spacer with/without pressure-tight feedthrough (second line of defense), optional
- Compact version, pipe extension or short pipe version
- Process connection

The individual heights of the components can be found in the following sections:

- Determine the height of the device and add the individual heights
- Take the installation clearance into consideration (space that is needed to install the device)

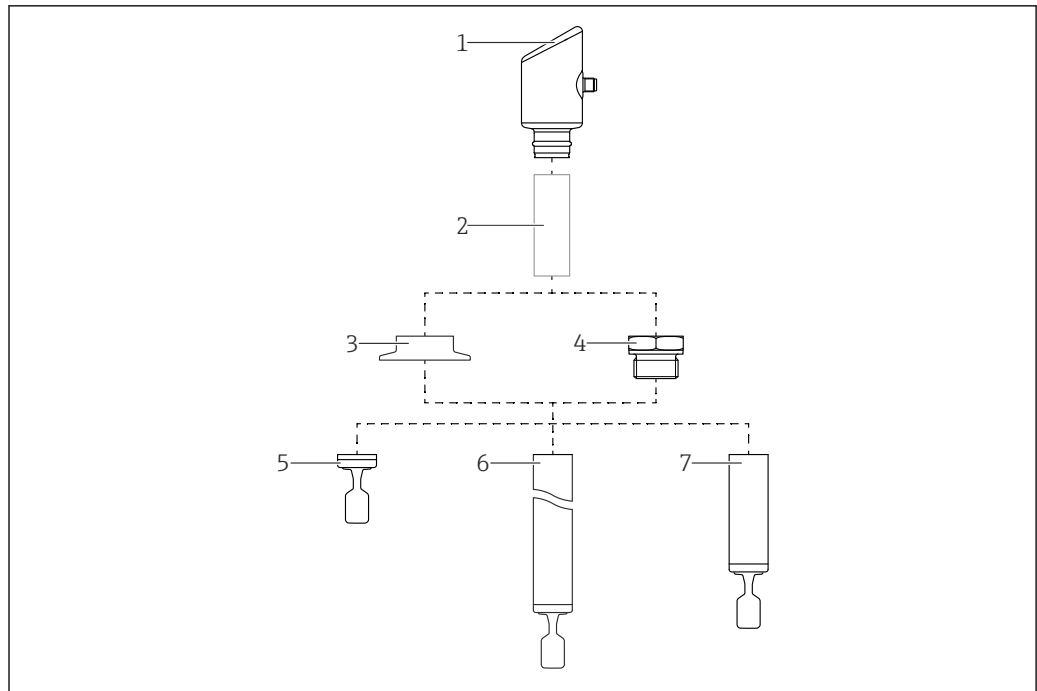

A0053358

15 Product design

- 1 Housing with electronics module
- 2 Temperature spacer, pressure-tight feedthrough (second line of defense), optional
- 3 Process connection, e.g. clamp/Tri-Clamp
- 4 Process connection, e.g. thread
- 5 Compact probe version with tuning fork
- 6 Pipe extension probe with tuning fork
- 7 Short pipe version of probe with tuning fork

Dimensions

Housing

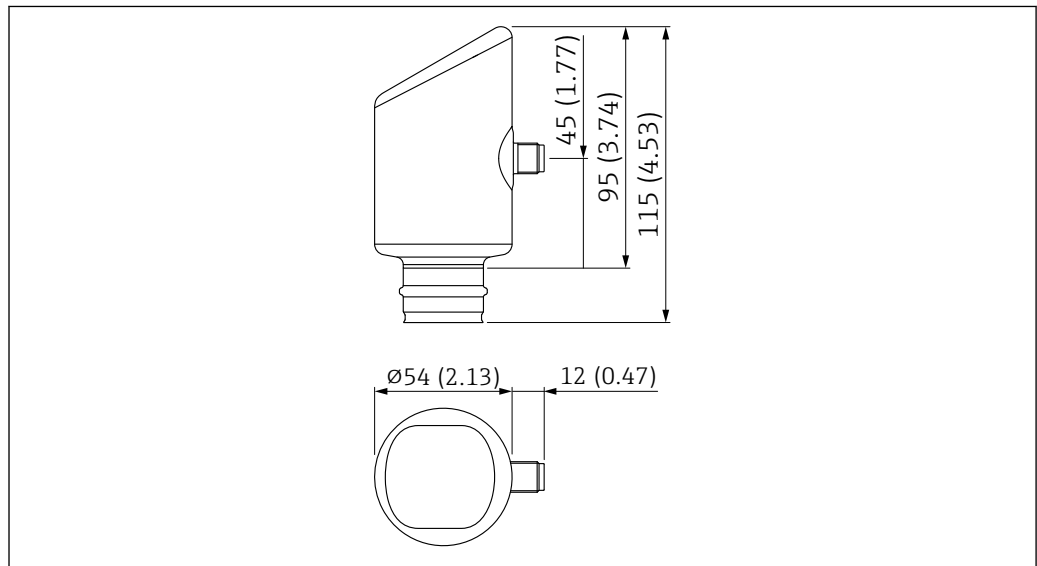

A0053970

Temperature spacer, pressure-tight feedthrough (optional)

Provides sealed insulation for the vessel and a normal ambient temperature for the housing.

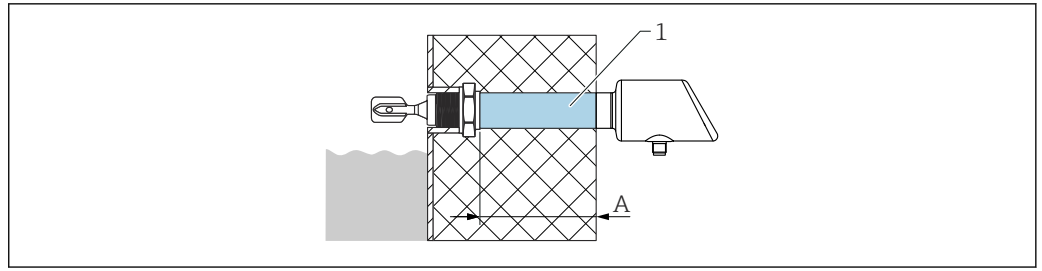

A0053111

- 1 Temperature spacer with/without pressure-tight feedthrough with maximum insulation length
- A 140 mm (5.51 in)

Product Configurator, feature "Sensor design":

- Temperature spacer
- Pressure-tight feedthrough (second line of defense)
If the sensor is damaged, this protects the housing from vessel pressures up to 100 bar (1 450 psi).

i The "Pressure-tight feedthrough" version can only be selected in conjunction with the "Temperature spacer" option.

Probe design

Compact version

Sensor length L: depends on process connection

i For more details, see the "Process connections" section.

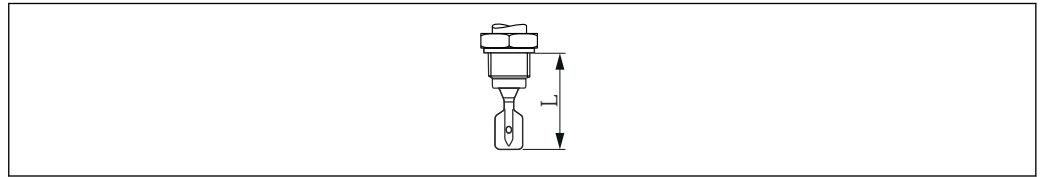

A0042435

i 16 Probe design: Compact version, sensor length L

Short tube version

Sensor length L: depends on process connection

- Thread G 1 approx. 118 mm (4.65 in)
- Ingold, flush-mounted tank connection, DIN11851 pipe union, Varivent, Clamp/Tri-Clamp approx. 115 mm (4.53 in)
- Flush-mounted 1" (G 1 welding boss from Endress+Hauser) approx. 104 mm (4.09 in)

Pipe extension

- Sensor lengths L: 148 to 1 500 mm (5.83 to 59.06 in)
- Length tolerances L: < 1 m (3.3 ft) = -5 mm (-0.2 in), 1 to 3 m (3.3 to 9.8 ft) = -10 mm (-0.39 in)

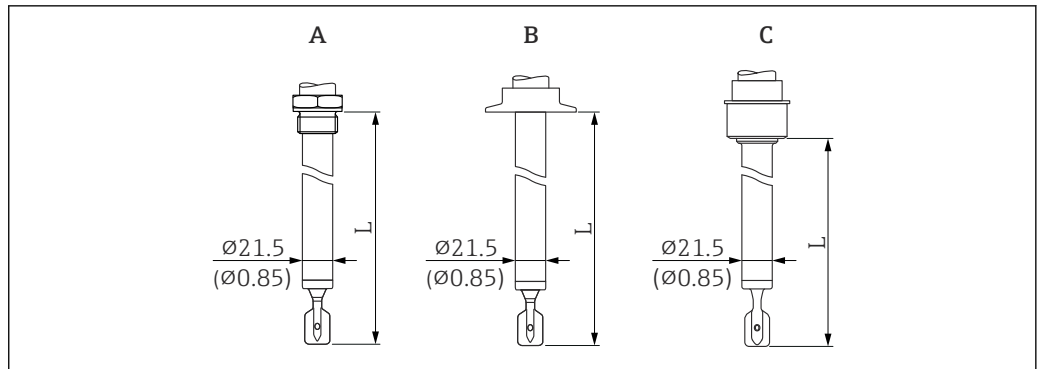

A0051989

i 17 Probe designs: pipe extension, short pipe (sensor length L). Unit of measurement mm (in)

- A Thread G 1
- B e.g. Clamp/Tri-Clamp, Varivent
- C Flush-mounted tank connection for installation in welding neck

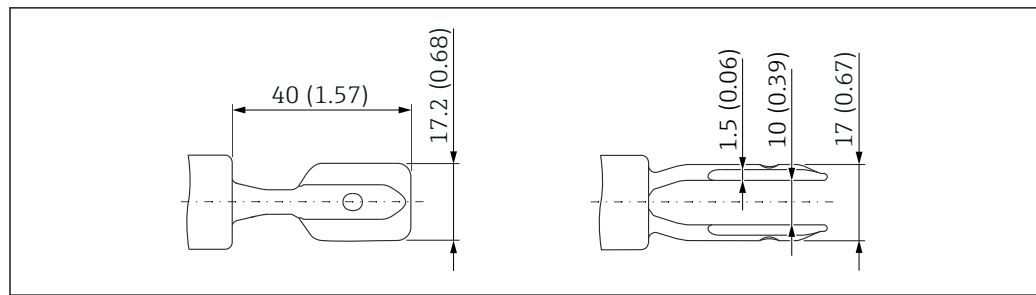
Tuning fork

A0038269

18 Tuning fork. Unit of measurement mm (in)

Weight

The weights of the individual components must be added together for the total weight.

Housing including electronics module

0.2 kg (0.44 lb)

Temperature spacer

0.6 kg (1.32 lb)

Pressure-tight feedthrough

0.7 kg (1.54 lb)

Pipe extension

- 1 000 mm: 0.9 kg (1.98 lb)
- 50 in: 1.15 kg (2.54 lb)

Process connection

See "Process connections" section

Materials**Materials in contact with process***Delta-ferrite content*

For the delta-ferrite content of the wetted parts, $\leq 1\%$ can be guaranteed and certified (for welds $\leq 3\%$).

Process connection and pipe extension

316L (1.4404 or 1.4435)

Tuning fork

316L (1.4435)

Seals

Scope of delivery including seal

- Ingold fitting, seal material: EPDM (in compliance with FDA, USP Class VI)
- Flush-mounted tank connection for installation in welding neck, seal material: silicone

Materials not in contact with process

- Housing: 316L (1.4404)
- Display: Polycarbonate
- Device plug: For more information, see section on "Power supply".

Process connections**Process connection, sealing surface**

- Flange ASME B16.5, RF
- Flange EN1092-1, A
- Flange EN1092-1, B1
- Thread ISO228, G
- Ingold
- Flush-mounted tank connection
- DIN11851 pipe union
- DIN11864-1 pipe union

- DRD
- SMS1145 pipe union
- Varivent (Varinline)
- Clamp/Tri-Clamp

Height of process connection

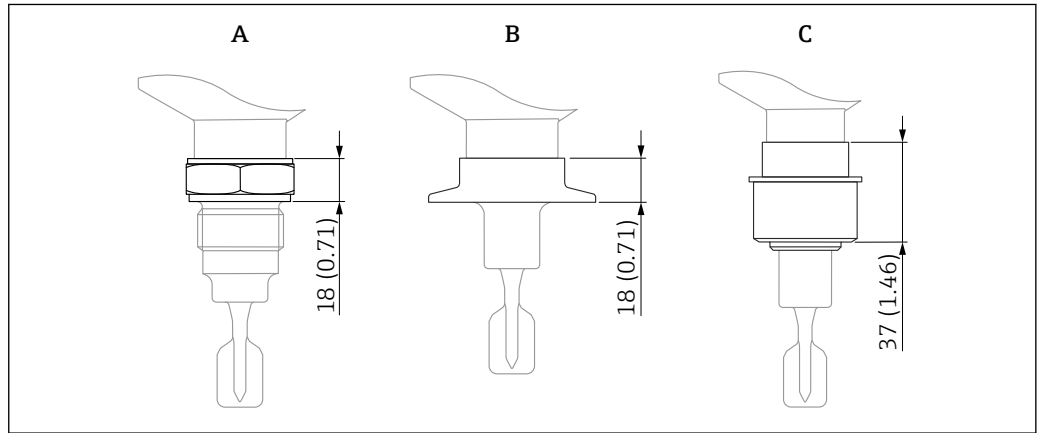

19 Maximum height specification for the process connections. Unit of measurement mm (in)

- A Process connection with threaded connection
- B For example: Clamp/Tri-Clamp, Varivent
- C Flush-mounted tank connection for installation in welding neck

Thread ISO228 G 3/4 for installation in weld-in adapter

G 3/4 with defined thread start for flush mounting in weld-in adapter

- Only for sensor design: compact version
- Material: 316L
- Pressure rating, temperature: ≤ 40 bar (580 psi), ≤ +100 °C (+212 °F)
- Pressure rating, temperature: ≤ 25 bar (363 psi), ≤ +150 °C (+302 °F)
- Weight: 0.2 kg (0.44 lb)
- Accessories: weld-in adapter, optionally available as "Accessory enclosed"

i A seal is not included in the delivery. The maximum temperature and maximum pressure depend on the clamping ring and sealing element used (according to the process connection design). The lowest value applies in each case.

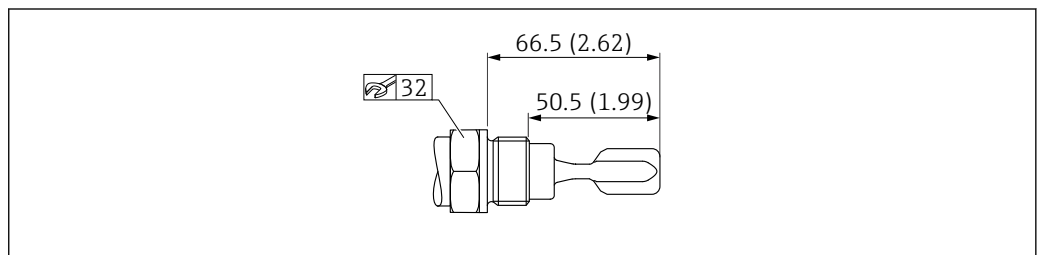

20 Thread ISO228 G 3/4. Unit of measurement mm (in)

Thread ISO228 G 1 for installation in weld-in adapter

G 1 with defined thread start, comprising sealing surface for flush mounting in weld-in adapter

- Material: 316L
- Pressure rating, temperature: ≤ 40 bar (580 psi), ≤ +100 °C (+212 °F)
- Pressure rating, temperature: ≤ 25 bar (363 psi), ≤ +150 °C (+302 °F)
- Weight: 0.33 kg (0.73 lb)
- Accessories: weld-in adapter, optionally available as "Accessory enclosed"

i A seal is not included in the delivery. The maximum temperature and maximum pressure depend on the clamping ring and sealing element used (according to the process connection design). The lowest value applies in each case.

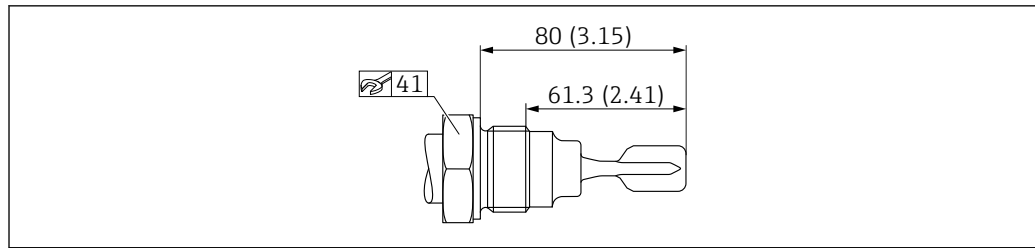

A0035551

21 Thread ISO228 G 1. Unit of measurement mm (in)

Ingold fitting

Ingold fitting 25 x 46 mm (2.52 in)

- Material: 316L
- Pressure rating: ≤ 16 bar (232 psi)
- Temperature: ≤ 150 °C (302 °F)
- Weight: 0.2 kg (0.44 lb)
- Scope of delivery: cap-nut G 1¼, seal

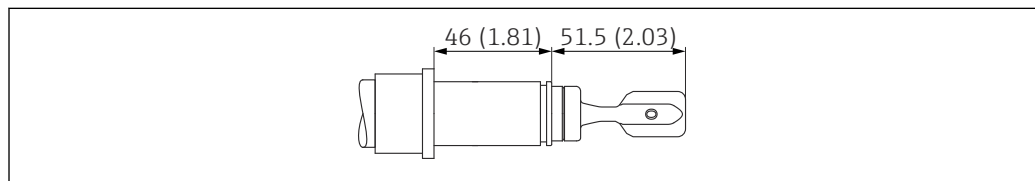

A0051991

22 Ingold fitting 25 x 46 mm (2.52 in). Unit of measurement mm (in)

Flush-mounted tank connection for installation in weld-in adapter

- Material: 316L
- Pressure rating, temperature: ≤ 40 bar (580 psi), $\leq +100$ °C (+212 °F)
- Pressure rating, temperature: ≤ 25 bar (363 psi), ≤ 140 °C (284 °F)
- Weight: 0.44 kg (0.97 lb)
- Accessories: weld-in adapter, optionally available as "Accessory enclosed"
- Scope of delivery: cap-nut, seal

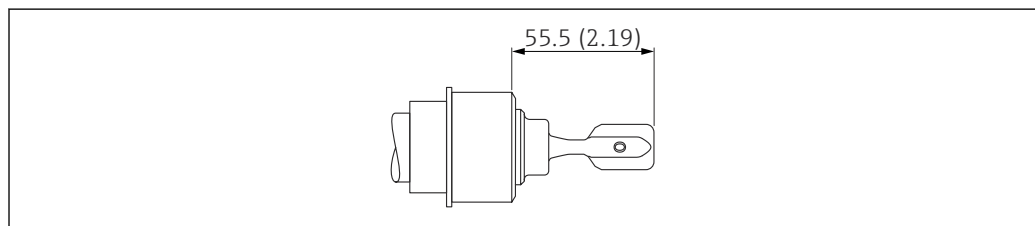

A0051993

23 Flush-mounted tank connection. Unit of measurement mm (in)

DIN11851 pipe union

DN32 PN25

- Material: 316L
- Slotted nut
- Pressure rating, temperature: ≤ 40 bar (580 psi), $\leq +100$ °C (+212 °F)
- Pressure rating, temperature: ≤ 25 bar (363 psi), ≤ 140 °C (284 °F)
- Weight: 0.3 kg (0.66 lb)

DN40 PN25

- Material: 316L
- Slotted nut
- Pressure rating, temperature: ≤ 40 bar (580 psi), $\leq +100$ °C (+212 °F)
- Pressure rating, temperature: ≤ 25 bar (363 psi), ≤ 140 °C (284 °F)
- Weight: 0.35 kg (0.77 lb)

DN50 PN25

- Material: 316L
- Slotted nut
- Pressure rating: ≤ 25 bar (363 psi)
- Temperature: ≤ 140 °C (284 °F)
- Weight: 0.47 kg (1.04 lb)

i A seal is not included in the delivery. The maximum temperature and maximum pressure depend on the clamping ring and sealing element used (according to the process connection design). The lowest value applies in each case.

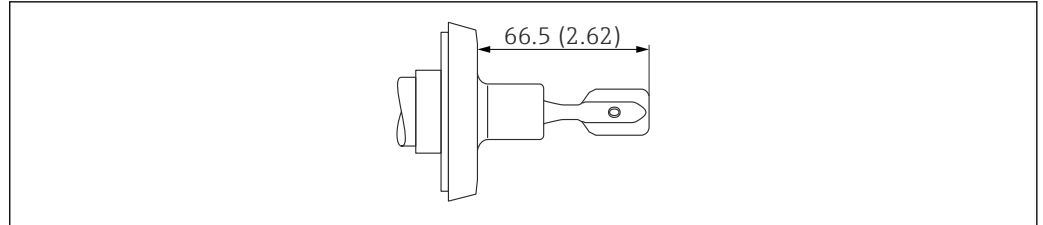

24 DIN11851 pipe union. Unit of measurement mm (in)

A0051995

DIN11864-1 pipe union

DIN11864-1 A DN50 pipe DIN11850

- Material: 316L
- Slotted nut
- Pressure rating: ≤ 25 bar (363 psi)
- Temperature: ≤ 140 °C (284 °F)
- Weight: 0.47 kg (1.04 lb)

i A seal is not included in the delivery. The maximum temperature and maximum pressure depend on the clamping ring and sealing element used (according to the process connection design). The lowest value applies in each case.

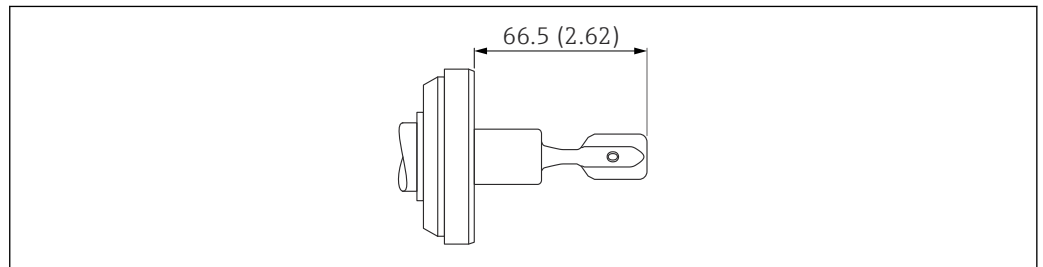

25 DIN11864-1 pipe union. Unit of measurement mm (in)

A0052381

DRD

DRD 65 mm (2.56 in)

- Material: 316L
- Pressure rating, temperature: ≤ 40 bar (580 psi), ≤ +100 °C (+212 °F)
- Pressure rating, temperature: ≤ 25 bar (363 psi), ≤ 140 °C (284 °F)
- Weight: 0.43 kg (0.95 lb)
- Accessories: welding flange with PTFE flat seal, optionally available as "Accessory enclosed"

i A seal is not included in the delivery. The maximum temperature and maximum pressure depend on the clamping ring and sealing element used (according to the process connection design). The lowest value applies in each case.

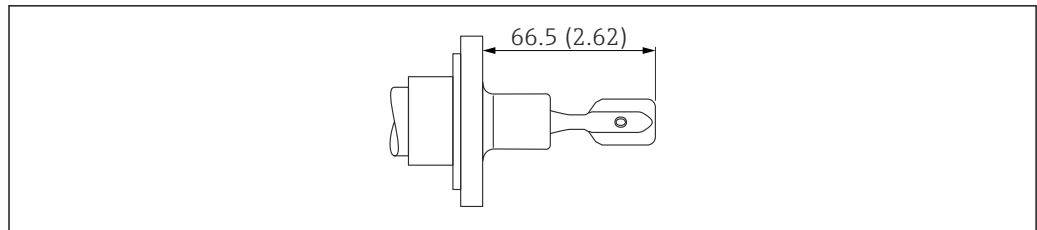

A0051992

26 DRD. Unit of measurement mm (in)

SMS1145 pipe union

SMS 2" PN25

- Material: 316L
- Pressure rating: ≤ 25 bar (363 psi)
- Temperature: ≤ 140 °C (284 °F)
- With cap-nut
- Weight: 0.33 kg (0.72 lb)

i A seal is not included in the delivery. The maximum temperature and maximum pressure depend on the clamping ring and sealing element used (according to the process connection design). The lowest value applies in each case.

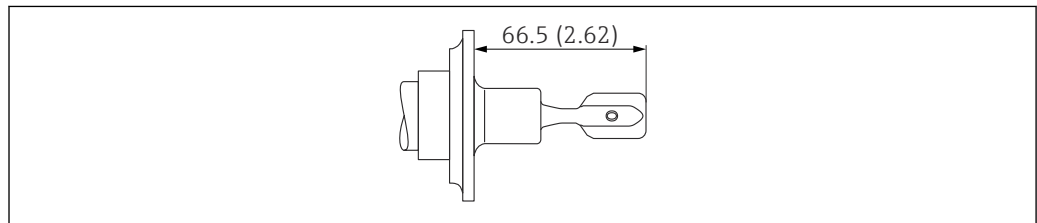

A0051994

27 SMS1145 pipe union. Unit of measurement mm (in)

Varivent (Varinline)

Varivent F pipe DN25-32 PN40

- Material: 316L
- Pressure rating: ≤ 25 bar (363 psi)
- Temperature: ≤ 150 °C (302 °F)
- Weight: 0.36 kg (0.79 lb)

i A seal is not included in the delivery. The maximum temperature and maximum pressure depend on the clamping ring and sealing element used (according to the process connection design). The lowest value applies in each case.

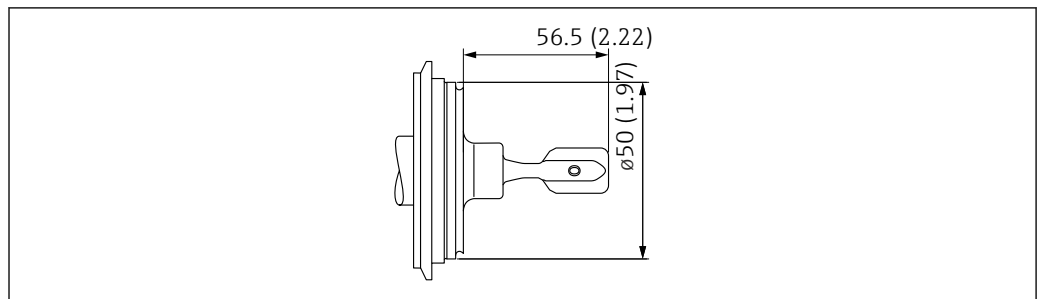

A0052749

28 Varivent F pipe DN25-32 PN40. Unit of measurement mm (in)

Varivent N pipe DN65-162 PN25

- Material: 316L
- Pressure rating: ≤ 25 bar (363 psi)
- Temperature: ≤ 150 °C (302 °F)
Suitable for GEA Tuchenhagen
- Weight: 0.72 kg (1.59 lb)

i A seal is not included in the delivery. The maximum temperature and maximum pressure depend on the clamping ring and sealing element used (according to the process connection design). The lowest value applies in each case.

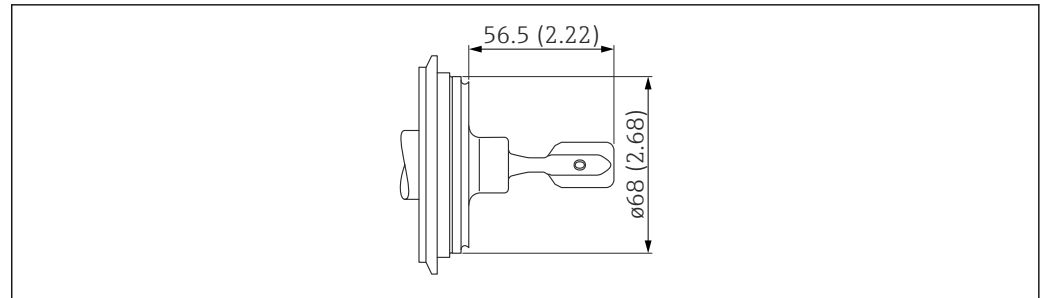

A0051996

30 Varivent N pipe DN65-162 PN25. Unit of measurement mm (in)

Tri-Clamp

ISO 2852 DN25-38 (1 to 1 ½"), DIN 32676 DN25-40

- Material: 316L
- Pressure rating: ≤ 25 bar (363 psi)
- Temperature: ≤ 150 °C (302 °F)
- Weight: 0.3 kg (0.66 lb)

ISO 2852 DN40-51 (2"), DIN 32676 DN50

- Material: 316L
- Pressure rating: ≤ 25 bar (363 psi)
- Temperature: ≤ 150 °C (302 °F)
- Weight: 0.3 kg (0.66 lb)

i The Tri-Clamp connection is compatible with NA Connect.

i A seal is not included in the delivery. The maximum temperature and maximum pressure depend on the clamping ring and sealing element used (according to the process connection design). The lowest value applies in each case.

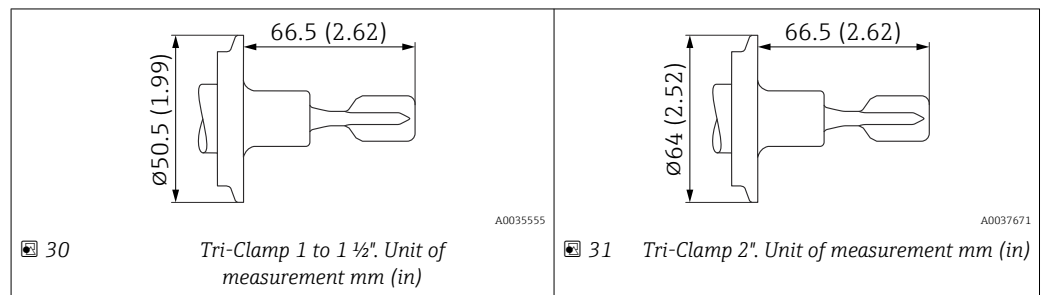

A0035555

A0037671

30 Tri-Clamp 1 to 1 ½". Unit of measurement mm (in)

31 Tri-Clamp 2". Unit of measurement mm (in)

Flanges

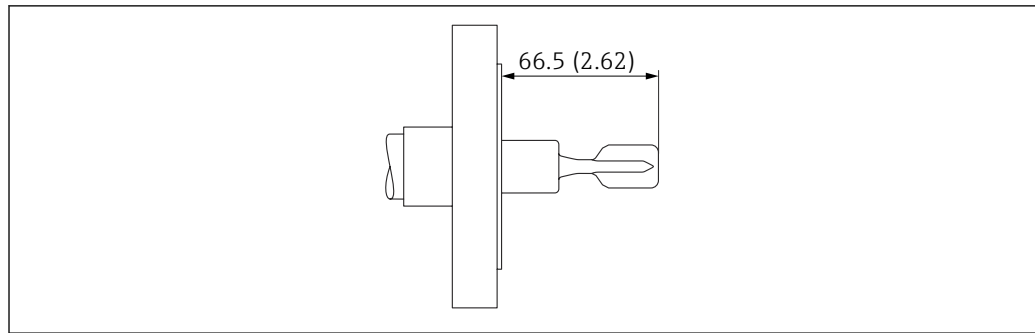

A0035554

32 Example with flange. Unit of measurement mm (in)

ASME B16.5 flanges, RF

Pressure rating	Type	Material	Weight
Cl.150	NPS 2"	316/316L	2.4 kg (5.29 lb)

EN flanges EN 1092-1, A

Pressure rating	Type	Material	Weight
PN25/40	DN25	316L (1.4404)	1.3 kg (2.87 lb)
PN25/40	DN50	316L (1.4404)	3.2 kg (7.06 lb)

EN flanges EN 1092-1, B1

Pressure rating	Type	Material	Weight
PN25/40	DN25	316L (1.4404)	1.4 kg (3.09 lb)
PN25/40	DN50	316L (1.4404)	3.2 kg (7.06 lb)

Surface roughness

- Housing: Ra <1.6 µm (63 µin), electropolished
- Parts in contact with process: Ra <1.5 µm (59.1 µin) CoC ASME BPE

Optional:

- Ra <0.3 µm (12 µin) mechanically polished (3-A, EHEDG)
- Ra <0.38 µm (15 µin) electropolished, (3-A, EHEDG, CoC ASME BPE)

In this version, the wetted parts are made of 316L (1.4435) in accordance with BN2 (delta-ferrite content < 1 %)

Display and user interface

Operation concept

Operator-oriented menu structure for user-specific tasks

- User navigation
- Diagnosis
- Application
- System

Quick and safe commissioning

- Interactive wizard with graphical interface for guided commissioning in FieldCare/DeviceCare or SmartBlue app
- Menu guidance with brief descriptions of the individual parameter functions
- Standardized operation at the device and in the operating tools

Integrated data memory

Up to 100 event messages recorded in the device

Efficient diagnostics increase measurement reliability

- Remedial measures are integrated in plain text
- Diverse simulation options

Bluetooth (optional)

- Quick and easy setup with the SmartBlue app or FieldXpert SMT70/SMT77
- No additional tools or adapters needed
- Encrypted single point-to-point data transmission (tested by Fraunhofer Institute) and password-protected communication via *Bluetooth*® wireless technology
- The LED display can be retrofitted with Bluetooth.

LED indicator

 The device is optionally available with Bluetooth® wireless technology.

Functions:

- Display of the operating status (operation or fault)
- Display of Bluetooth connection, locking status and function
- Easy setup of the following functions with one button:
 - Bluetooth On/Off
 - Locking On/Off
 - Trigger proof test or functional test

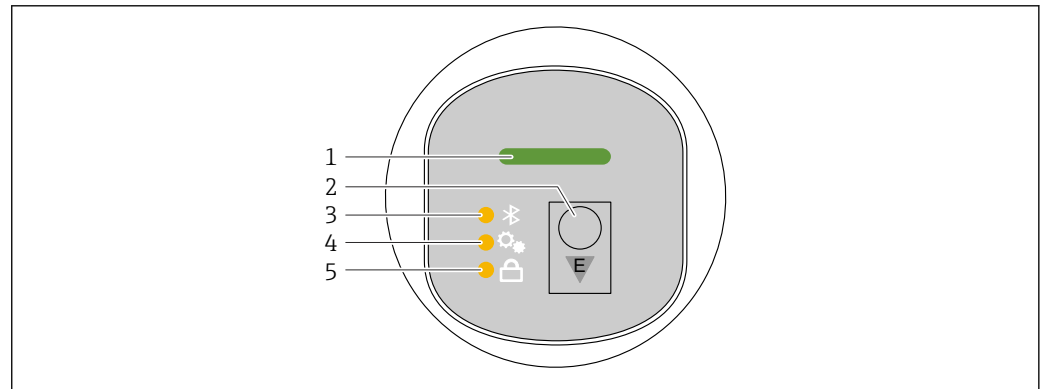

A0052426

- 1 *Operating status LED*
- 2 *Operating key "E"*
- 3 *Bluetooth LED*
- 4 *Trigger proof test or functional test LED*
- 5 *Keypad lock LED*

Proof-test function

For proof testing in safety instrumented systems according to WHG

 The operating status LED shows the simulation status generated by the proof test.

Remote operation

Via HART protocol or Bluetooth

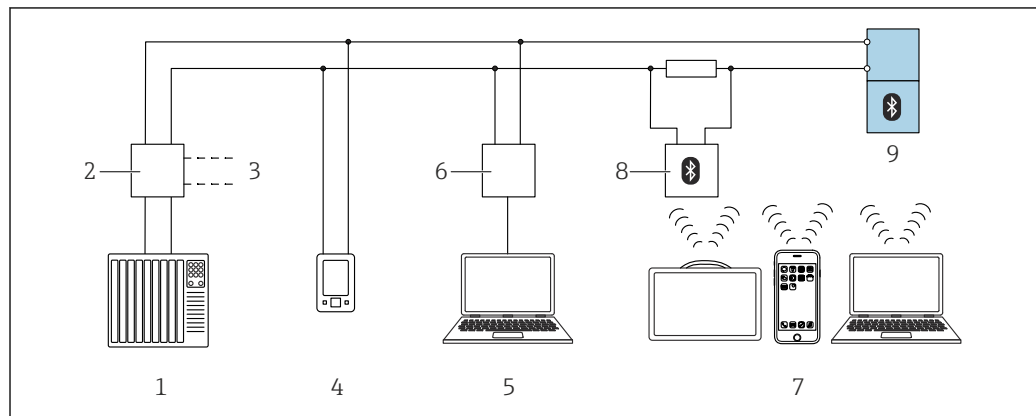

A0044334

33 Options for remote operation via HART protocol

- 1 PLC (programmable logic controller)
- 2 Transmitter power supply unit, e.g. RN42 (with communication resistor)
- 3 Connection for Commubox FXA195 and AMS Trex™ device communicator
- 4 AMS Trex™ device communicator
- 5 Computer with operating tool (e.g. DeviceCare/FieldCare, AMS Device View, SIMATIC PDM)
- 6 Commubox FXA195 (USB)
- 7 Field Xpert SMT70/SMT77, smartphone or computer with operating tool (e.g. DeviceCare/FieldCare, AMS Device View, SIMATIC PDM)
- 8 Bluetooth modem with connecting cable (e.g. VIATOR)
- 9 Transmitter

Operation via Bluetooth® wireless technology (optional)

Prerequisite

- Device with Bluetooth order option
- Smartphone or tablet with Endress+Hauser SmartBlue app or PC with DeviceCare from version 1.07.07 or FieldXpert SMT70/SMT77

The connection has a range of up to 25 m (82 ft). The range can vary depending on environmental conditions such as attachments, walls or ceilings.



The operating keys on the display are locked as soon as the device is connected via Bluetooth.

System integration

Version 7.6

Supported operating tools



Smartphone or tablet with Endress+Hauser SmartBlue app, DeviceCare from version 1.07.07, FieldCare, AMS and PDM

Certificates and approvals

Current certificates and approvals for the product are available at www.endress.com on the relevant product page:

1. Select the product using the filters and search field.
2. Open the product page.
3. Select **Downloads**.

Other certificates and approvals for the product are available under <https://www.endress.com> -> Downloads.

Hygienic design requirements	<ul style="list-style-type: none"> ■ Notes on installation and certification in accordance with 3-A and EHEDG: <ul style="list-style-type: none">  SD02503F document "Hygienic approvals" ■ Information on 3-A and EHEDG-certified adapters: <ul style="list-style-type: none">  TI00426F document "Weld-in adapters, process adapters and flanges" ■ 3-A and EHEDG-certified versions of the sensor are suitable for Cleaning-in-Place (CIP) and Sterilization-in-Place (SIP) without removing them from the plant. This means that the sensor does not need to be removed during cleaning. The maximum permitted pressure and temperature values for sensor and adapter must not be exceeded (see notes in this TI). ■ ASME BPE
Compliance with requirements derived from cGMP	<p>cGMP is suitable for wetted parts:</p> <ul style="list-style-type: none"> ■ The certificate is only available in English ■ Materials of construction ■ ADI-free based upon EMA/410/01 Rev.3 (TSE/BSE compliant) ■ Polishing and surface finish ■ Material/compound compliance table: USP, FDA
TSE (BSE) compliance (ADI free - Animal Derived Ingredients)	<p>As the manufacturer, Endress+Hauser states:</p> <ul style="list-style-type: none"> ■ That the parts of this product in contact with the process are not made from materials derived from animals or ■ at least comply with the requirements of guidelines outlined in EMA/410/01 rev. 3 (TSE (BSE) compliance).
Industry Canada	CNR-Gen Section 7.1.3
ASME BPE	The measuring system meets the requirements of the ASME BPE standard (Bioprocessing Equipment).

Ordering information

Detailed ordering information is available from your nearest sales organization www.addresses.endress.com or in the Product Configurator at www.endress.com:

1. Select the product using the filters and search field.
2. Open the product page.
3. Select **Configuration**.



Product Configurator - the tool for individual product configuration

- Up-to-the-minute configuration data
- Depending on the device: Direct input of measuring point-specific information such as measuring range or operating language
- Automatic verification of exclusion criteria
- Automatic creation of the order code and its breakdown in PDF or Excel output format
- Ability to order directly in the Endress+Hauser Online Shop

Identification

Measuring point (TAG)

The device can be ordered with a tag name.

Location of tag name

Select in the additional specification:

- Stainless steel wired-on tag plate
- Paper adhesive label
- Tag provided by the customer
- Nameplate
- IEC 61406 stainless steel tag
- IEC 61406 stainless steel + NFC tag
- IEC 61406 stainless steel, stainless steel tag
- IEC 61406 stainless steel + NFC, stainless steel
- IEC 61406 stainless steel tag, plate provided
- IEC 61406 stainless steel + NFC, plate provided

Definition of tag name

Specify in the additional specification:

3 lines of maximum 18 characters each

The specified tag name appears on the selected plate.

Visualization in SmartBlue app

The first 32 characters of the tag name

The tag name can always be changed specifically for the measuring point via Bluetooth.

Display on the nameplate

The first 16 characters of the tag name

Display in electronic nameplate (ENP)

The first 32 characters of the tag name



For details, see document SD03128P

Application packages

The application package can be ordered together with the device or can be activated subsequently with an activation code. Detailed information on the relevant order code is available from the website www.endress.com or from the Endress +Hauser Sales Center.

Heartbeat Technology

Heartbeat Technology offers diagnostic functionality through continuous self-monitoring, the transmission of additional measured variables to an external Condition Monitoring system and the in situ verification of devices in the application.

Heartbeat Diagnostics

Continuous self-monitoring of the device.

Diagnostic messages output to:

- the onsite display
- an asset management system (e.g. FieldCare or DeviceCare)
- an automation system (e.g. PLC)

Heartbeat Verification

- Monitoring of the installed device without interrupting the process, including a verification report
- Clear measuring point assessment (pass/fail) with high total test coverage as part of the manufacturer's specification
- Can be used to document normative requirements
- Meets the requirements for measurement traceability in accordance with ISO 9001 (ISO 9001:2015 Section 7.1.5.2)



The verification report can be generated via Bluetooth and HART.

Heartbeat Monitoring

- Continuously provides device and/or process data for an external system. Analysis of these data provides a basis for process optimization and predictive maintenance.
- **Loop diagnostics** wizard: Detection of elevated measuring circuit resistance values or declining power supply
- **Process window** wizard: Two frequency limits for monitoring the upper and lower range of the oscillation frequency (can be defined independently of one another). Changes in the process can be identified, e.g. corrosion or buildup.
- **Safety mode** wizard: The device can be write-protected via the software using this wizard. The safety-related parameters must be confirmed in the wizard.

Detailed description

See Special Documentation for SD Heartbeat Technology.

"Medium detection" operating mode



Default setting of operating mode (as-delivered state): point level detection of liquids. This setting covers most applications.

In addition, the following operating modes can be selected in combination with the Heartbeat package:

- Foam detection
- Foam suppression

Foam detection

Area of application: point level detection in liquids with foam generation.

The device detects the foam and switches as soon as the tuning fork is immersed in the foam or when the fork is uncovered.

 Application in accordance with the WHG (German Water Resources Act) is not possible in this operating mode.

Detection of light foams such as:

- Beer foam
- Milk foam

Influence on switching behavior:

- Particularly large air bubbles in the foam
- Significantly reduced liquid content in the foam
- Change in the properties of the foam during operation

Foam suppression

Area of application: point level detection in liquids with foam generation.

The device only switches when immersed in a homogeneous liquid.

The device does not react to the foam in this setting (is suppressed).

 Application in accordance with the WHG (German Water Resources Act) is not possible in this operating mode.

Accessories

Accessories currently available for the product can be selected via the Product Configurator at www.endress.com:

1. Select the product using the filters and search field.
2. Open the product page.
3. Select **Spare parts & Accessories**.

Device-specific accessories

M12 socket

M12 socket, straight

- Material:
Body: PA; union nut: stainless steel; seal: EPDM
- Degree of protection (fully locked): IP69
- Order number: 71638191

M12 socket, elbowed

- Material:
Body: PA; union nut: stainless steel; seal: EPDM
- Degree of protection (fully locked): IP69
- Order number: 71638253

Cables

Cable 4 x 0.34 mm² (20 AWG) with M12 socket, elbowed, screw plug, length 5 m (16 ft)

- Material: body: TPU; union nut: nickel-plated die-cast zinc; cable: PVC
- Degree of protection (fully locked): IP68/69
- Order number: 52010285
- Wire colors
 - 1 = BN = brown
 - 2 = WT = white
 - 3 = BU = blue
 - 4 = BK = black

Welding neck, process adapter and flange



For details, refer to TI00426F/00/EN "Weld-in adapters, process adapters and flanges".

DeviceCare SFE100

Configuration tool for IO-Link, HART, PROFIBUS and FOUNDATION Fieldbusfield devices
DeviceCare is available for download free of charge at www.software-products.endress.com. You need to register in the Endress+Hauser software portal to download the application.



Technical Information TI01134S

FieldCare SFE500

FDT-based plant asset management tool
It can configure all intelligent field units in your system and helps you manage them. By using the status information, it is also a simple but effective way of checking their status and condition.



Technical Information TI00028S

Device Viewer

All the spare parts for the device, along with the order code, are listed in the *Device Viewer* (www.endress.com/deviceviewer).

Field Xpert SMT70

Universal, high-performance tablet PC for device configuration in Ex Zone 2 and non-Ex areas



For details, see "Technical Information" TI01342S

Field Xpert SMT77

Universal, high-performance tablet PC for device configuration in Ex Zone 1 areas



For details, see "Technical Information" TI01418S

SmartBlue app

Mobile app for easy configuration of devices on site via Bluetooth wireless technology

Documentation



For an overview of the scope of the associated Technical Documentation, refer to the following:

- *Device Viewer* (www.endress.com/deviceviewer): Enter the serial number from the nameplate
- *Endress+Hauser Operations app*: Enter serial number from nameplate or scan matrix code on nameplate.

Standard documentation

Document type: Operating Instructions (BA)

Installation and initial commissioning – contains all the functions in the operating menu that are needed for a routine measuring task. Functions beyond this scope are not included.

Document type: Description of Device Parameters (GP)

The document is part of the Operating Instructions and serves as a reference for parameters, providing a detailed explanation of each individual parameter of the operating menu.

Document type: Brief Operating Instructions (KA)

Quick guide to the first measured value – includes all essential information from incoming acceptance to electrical connection.

Document type: Safety Instructions, certificates

Depending on the approval, safety instructions are supplied with the device, e.g. XA. This documentation is an integral part of the Operating Instructions. Information on the Safety Instructions (XA) that are relevant for the device is provided on the nameplate.

Supplementary device-dependent documentation

Additional documents are supplied depending on the device version ordered: Always comply strictly with the instructions in the supplementary documentation. The supplementary documentation is an integral part of the device documentation.

Registered trademarks

Apple®

Apple, the Apple logo, iPhone, and iPod touch are trademarks of Apple Inc., registered in the U.S. and other countries. App Store is a service mark of Apple Inc.

Android®

Android, Google Play and the Google Play logo are trademarks of Google Inc.

Bluetooth®

The *Bluetooth*® word mark and logos are registered trademarks owned by the Bluetooth SIG, Inc. and any use of such marks by Endress+Hauser is under license. Other trademarks and trade names are those of their respective owners.

HART®

Registered trademark of the FieldComm Group, Austin, Texas USA



www.addresses.endress.com
