

Safety Instructions

Proservo

NMS80, NMS81

ATEX: II 1/2G Ex d[ia] IIC T6...T1 Ga/Gb
IECEX: Ex db[ia Ga] IIC T6...T1 Ga/Gb





Proservo

NMS80, NMS81

Table of contents

Associated documentation	4
Supplementary documentation	4
Manufacturer's certificates	4
Manufacturer address	4
Other standards	4
Extended order code	5
Safety instructions: General	7
Safety instructions: Special conditions	8
Safety instructions: Installation	8
Safety instructions: Zone 0	12
Connection data	12

Associated documentation	<p>This document is an integral part of the following Operating Instructions:</p> <ul style="list-style-type: none">■ BA01456G (NMS80)■ BA01459G (NMS81)
Supplementary documentation	<p>Explosion protection brochure: CP00021Z/11</p> <p>The Explosion-protection brochure is available:</p> <ul style="list-style-type: none">■ In the download area of the Endress+Hauser website: www.endress.com -> Downloads -> Media Type: Documentation -> Documentation Type: Brochures and catalogs -> Text Search: CP00021Z■ On the CD for devices with CD-based documentation
Manufacturer's certificates	<p>EU Declaration of Conformity</p> <p>Declaration Number: EC 00737</p> <p>The EU Declaration of Conformity is available: In the download area of the Endress+Hauser website: www.endress.com -> Downloads -> Declaration -> Type: EU Declaration -> Product Code: ...</p> <p>EU type-examination certificate</p> <p>Certificate number: FM 16 ATEX 0001X</p> <p>List of applied standards: See EU Declaration of Conformity.</p> <p>IEC Declaration of Conformity</p> <p>Certificate number: IECEX FMG 16.0001X</p> <p>Affixing the certificate number certifies conformity with the following standards (depending on the device version):</p> <ul style="list-style-type: none">■ IEC 60079-0 : 2017■ IEC 60079-1: 2014■ IEC 60079-11 : 2011■ IEC 60079-26 : 2014■ IEC 60529 : 2013 <p>KCs Certificate of Conformity</p> <ul style="list-style-type: none">■ Certificate number: NMS80 24-KA4BO-0520X, 24-KA4BO-00521X NMS81 24-KA4BO-0522X, 24-KA4BO-0523X■ Safety Certification Notice for Protective Devices No. 2021-22
Manufacturer address	<p>Endress+Hauser Yamanashi Co., Ltd. 406-0846 862-1 Mitsukunugi, Sakaigawa-cho, Fuefuki-shi, Yamanashi</p>
Other standards	<p>Among other things, the following standards shall be observed in their current version for proper installation:</p> <ul style="list-style-type: none">■ IEC/EN 60079-14: "Explosive atmospheres - Part 14: Electrical installations design, selection and erection"■ EN 1127-1: "Explosive atmospheres - Explosion prevention and protection - Part 1: Basic concepts and methodology"

Extended order code

The extended order code is indicated on the nameplate, which is affixed to the device in such a way that it is clearly visible. Additional information about the nameplate is provided in the associated Operating Instructions.

Structure of the extended order code

NMS8x - ***** + A*B*C*D*E*F*G*..
 (Device type) (Basic specifications) (Optional specifications)

* = Placeholder
 At this position, an option (number or letter) selected from the specification is displayed instead of the placeholders.

Basic specifications

The features that are absolutely essential for the device (mandatory features) are specified in the basic specifications. The number of positions depends on the number of features available. The selected option of a feature can consist of several positions.

Optional specifications

The optional specifications describe additional features for the device (optional features). The number of positions depends on the number of features available. The features have a 2-digit structure to aid identification (e.g. JA). The first digit (ID) stands for the feature group and consists of a number or a letter (e.g. J = Test, Certificate). The second digit constitutes the value that stands for the feature within the group (e.g. A = 3.1 material (wetted parts), inspection certificate).

More detailed information about the device is provided in the following tables. These tables describe the individual positions and IDs in the extended order code which are relevant to hazardous locations.

Extended order code: Proservo

-  The following specifications reproduce an extract from the product structure and are used to assign:
- This documentation to the device (using the extended order code on the nameplate).
 - The device options cited in the document.

Device type

NMS80, NMS81

Basic specifications

Position 1, 2 (Approval)		
Selected option		Description
NMS8x	BC	ATEX II 1/2G Ex d ia Ga IIC T6...T1 Ga/Gb
	IC	IECEX IEC Ex db ia Ga IIC T6...T1 Ga/Gb
	KC	KCs Ex db ia Ga IIC T6...T1 Ga/Gb

Position 5, 6 (Primary Output)		
Selected option		Description
NMS8x	A1	Modbus RS485
	B1	V1
	C1	WM550
	E1	4 to 20 mA HART Ex d/XP
	H1	4 to 20 mA HART Ex i/IS

Position 7, 8 (Secondary I/O Analogue)		
Selected option		Description
NMS8x	A1	Ex d, 1x 4 to 20 mA HART, 1x RTD input
	A2	Ex d, 2x 4 to 20 mA HART, 2x RTD input
	B1	Ex i, 1x 4 to 20 mA HART, 1x RTD input
	B2	Ex i, 2x 4 to 20 mA HART, 2x RTD input
	C2	1x Ex i 4 to 20 mA HART, 2x RTD input + 1x Ex d 4-20 mA HART
	X0	Prepared for I/O analogue, RTD input

Position 9, 10 (Secondary I/O Digital Ex d/XP)		
Selected option		Description
NMS8x	A1	2x relay + 2x module discrete
	A2	4x relay + 4x module discrete
	A3	6x relay + 6x module discrete
	B1	Modbus RS485
	B2	Modbus RS485 + 2x relay + 2x module discrete
	B3	Modbus RS485 + 4x relay + 4x module discrete
	C1	V1
	C2	V1 + 2x relay + 2x module discrete
	C3	V1 + 4x relay + 4x module discrete
	E1	WM550
	E2	WM550 + 2x relay + 2x module discrete
	E3	WM550 + 4x relay + 4x module discrete
	X0	Prepared for I/O digital, Ex d

Position 11, 12 (Housing)		
Selected option		Description
NMS80	AB	Transmitter+Process Alu coated
NMS81	AC	Transmitter Alu coated + Process 316/316L
	AD	Transmitter Alu coated + Process 316/316L internal FEP
	BC	Transmitter+Process 316/316L
	BD	Transmitter 316/316L + Process 316/316L internal FEP

Position 13 (Process Pressure)		
Selected option		Description
NMS80	1	0 to 0.2 bar/20 kPa/2.9 psi
	2	0 to 6 bar/600 kPa/87 psi
NMS81	1	0 to 0.2 bar/20 kPa/2.9 psi
	2	0 to 6 bar/600 kPa/87 psi
	3	0 to 25 bar/2.5 MPa/362 psii

Position 17, 18, 19 (Displacer material: Type)		
Selected option		Description
NMS80	1AA	316L; 30 mm (1.18 in) Cylindrical
NMS81	1AC	316L; 50 mm (1.97 in) Cylindrical
	1BE	316L; 70 mm (2.76 in) Conical
	1BJ	316L; 110 mm (4.33 in) Conical
	2AA	PTFE; 30 mm (1.18 in) Cylindrical
	2AC	PTFE; 50 mm (1.97 in) Cylindrical
	3AC	Alloy-C; 50 mm (1.97 in) Cylindrical

Position 20, 21 (Process sealing)		
Selected option		Description
NMS8x	A1	HNBR -30 to 150 °C
	B1	FKM GLT, -40 to 200 °C
	C1	CR Chloroprene -25 to 100 °C
	D1	PTFE (wire drum FKM) -100 to 200 °C
	E1	VMQ Silicone -45 to 200 °C

Optional specifications

ID (Accessory Enclosed)		
Selected option		Description
NMS8x	PA	Weather protection cover
	RA	Relief valve, Rc3/8
	RB	Purge nozzle connection, Rc3/8
	RC	Pressure gauge, Rc3/8
	RD	Rc3/8 cleaning nozzle
	RG	Guide wire assembly

Safety instructions: General

- Staff must meet the following conditions for mounting, electrical installation, commissioning and maintenance of the device:
 - Be suitably qualified for their role and the tasks they perform
 - Be trained in explosion protection
 - Be familiar with national regulations
- Install the device according to the manufacturer's instructions and national regulations.
- Do not operate the device outside the specified electrical, thermal and mechanical parameters.
- Only use the device in media to which the wetted materials have sufficient durability.
- Avoid electrostatic charging:
 - Of plastic surfaces (e.g. housing, sensor element, special varnishing, attached additional plates, ..)
 - Of isolated capacities (e.g. isolated metallic plates)
- Refer to the temperature tables for the relationship between the permitted ambient temperature for the sensor and/or transmitter, depending on the range of application and the temperature class.
- Modifications to the device can affect the explosion protection and must be carried out by staff authorized to perform such work by Endress+Hauser.

Safety instructions:
Special conditions

Permitted ambient temperature range at the electronics housing:
 $-40\text{ °C} \leq T_a \leq +50, +55, \text{ or } +60\text{ °C}$
 Observe the information in the temperature table on page → 9

- Use supply wires suitable for 20 K above the ambient temperature.
- In the event of additional or alternative special varnishing on the housing or other metal parts:
 - Observe the danger of electrostatic charging and discharge.
 - Do not rub surfaces with a dry cloth.

Special conditions of use ATEX/IECEX

- Flamepath joints are not for repair. Contact the manufacturer.
- Use heat resisting cables rated $\geq 85\text{ °C}$ for $T_a > 50\text{ °C}$.
- Precautions shall be taken to minimize the risk from electrostatic discharge of non-metallic labels and isolated metal tags applied to the enclosure.
- To maintain the ingress protection ratings (IP66/68), teflon tape or pipe dope is required for blanking plugs.
- Ex d certified seals are required within 50 mm (1.97 in) on all used housing entries.

Safety instructions:
Installation

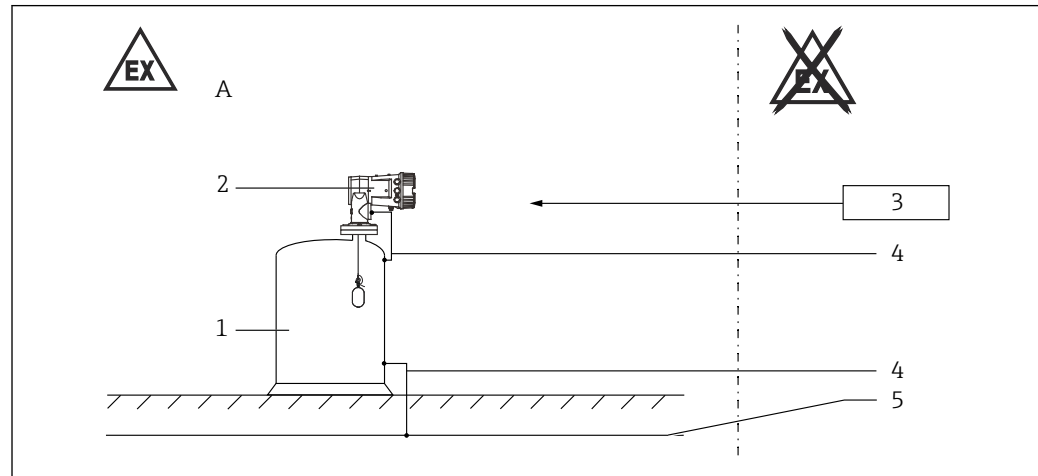

- A Zone 1
 1 Tank; Zone 0, Zone 1
 2 Connection and electronics compartment Ex d
 3 Power supply
 4 Potential equalization line
 5 Potential equalization

- Install the device to exclude any mechanical damage or friction during the application. Pay particular attention to flow conditions and tank fittings.
- Continuous service temperature of the connecting cable: -40 to $\geq +xx\text{ °C}$; in accordance with the range of service temperature taking into account additional influences of the process conditions ($T_{a,min}$), ($T_{a,max} + 30\text{ K}$). (→ 9, "Ambient temperature").
- In potentially explosive atmospheres:
 - Do not disconnect the electrical connection of the power supply circuit when energized.
 - Do not open the connection compartment cover.
- Only use certified cable entries suitable for the application. Observe national regulations and standards. Accordingly, the connection terminal does not include any ignition sources.
- When operating the transmitter housing at an ambient temperature under -20 °C , use appropriate cables and cable entries permitted for this application.
- When connecting through a conduit entry approved for this purpose, mount the associated sealing unit directly at the housing.

- Seal unused entry glands with approved sealing plugs that correspond to the type of protection. The plastic transport sealing plug does not meet this requirement and must therefore be replaced during installation.
- Before operation:
 - Screw in the cover all the way.
 - Tighten the securing clamp on the cover.
- The installation of the tank gauge NMS80/81/83 is to be made in such a way that no waving or rolling motion of the displacer can occur in operation causing a contact of the displacer with the tank wall. In case of the drum housing made of aluminum (NMS80), any impact or friction to the equipment has to be avoided in order to prevent an ignition hazard between the drum housing and internal parts.

Separation of Zone 0 and Zone1

The partition wall between the drum compartment (Zone 0) and electronic compartment (Zone 1) meets requirement 4.2.5.3 i) of IEC 60079-26. Maximum working pressure of the drum compartment is below.

Device type	Maximum Working Pressure (MWP) for Single Process Seal
NMS80-*****1...	0.02 MPa (0.2 bar) or
NMS80-*****2...	0.6 MPa (6 bar)
NMS81-*****1...	0.02 MPa (0.2 bar) or
NMS81-*****2...	0.6 MPa (6 bar)
NMS81-*****3...	2.5 MPa (25 bar)

Potential equalization

Integrate the device into the local potential equalization.

Overvoltage protection

Overvoltage protection against atmospheric overvoltages.

The following Terminal outputs / configurations need no separate external overvoltage protection measures:

Position	Terminal
Power supply	G
HART interface	E
external Display	F

- Device configuration:
 - *Basic specification, Position 5, 6 (Primary output)* = A1, B1, C1, E1, H1
 - *Basic specification, Position 7, 8 (Secondary I/O Analogue)* = A1, A2, B1, B2, C2, X0
 - *Basic specification, Position 9, 10 (Secondary I/O Digital Ex d/XP)* = B1, C1, E1
- All other configurations must be protected by separate additional measures to comply national regulations and standards.
- Observe the safety instructions of the overvoltage protection.

Ambient temperature

Temperature class	Ambient temperature	Process temperature (Temperature of displacer)
T1	-40 °C ≤ Ta ≤ 60 °C -40 °C ≤ Ta ≤ 55 °C -40 °C ≤ Ta ≤ 50 °C (See the tables below.)	-253 °C ≤ Tpro ≤ 450 °C
T2		-253 °C ≤ Tpro ≤ 300 °C
T3		-253 °C ≤ Tpro ≤ 200 °C
T4		-253 °C ≤ Tpro ≤ 135 °C

Temperature class	Ambient temperature	Process temperature (Temperature of displacer)
T5		$-253\text{ °C} \leq T_{\text{pro}} \leq 100\text{ °C}$
T6		$-253\text{ °C} \leq T_{\text{pro}} \leq 85\text{ °C}$

Table1: Basic specification, Position 11, 12 (Housing) = AB

Permitted ambient temperature range Ta (ambient)
$-40\text{ °C} \leq T_a \leq 60\text{ °C}$

Table2: Basic specification, Position 11, 12 (Housing) = AC, AD Configuration of electronics:

Configuration	Slot A / B / C / D				Permitted ambient temperature range Ta (ambient)
	IOM_V1/WM	IOM_Mod/FF	IOM_A [Ex i] / [Ex d]	IOM_D	
1			1	3	$-40\text{ °C} \leq T_a \leq 55\text{ °C}$
Combinations other than the list above					$-40\text{ °C} \leq T_a \leq 60\text{ °C}$

Table3: Basic specification, Position 11, 12 (Housing) = BC, BD Configuration of electronics:

Configuration	Slot A / B / C / D				Permitted ambient temperature range Ta (ambient)
	IOM_V1/WM	IOM_Mod/FF	IOM_A [Ex i] / [Ex d]	IOM_D	
1	1			3	$-40\text{ °C} \leq T_a \leq 50\text{ °C}$
2	1		1	2	
3	1		2	1	
4		1		3	
5			2	2	
6			1	3	
7	1		1	1	$-40\text{ °C} \leq T_a \leq 55\text{ °C}$
8	1			2	
9		1	2	1	
10		1	1	2	
11		1		2	
12			2	1	
13			1	2	
14		2		2	
15		1	1	1	
16		2	1	1	
17		2	2		
18	1	1		2	
19	2			2	
20	2		1	1	
21	1	1	2		
22	2		2		
23	1	1	1	1	
Combinations other than the list above					$-40\text{ °C} \leq T_a \leq 60\text{ °C}$

Measure low or high temperature liquid

- The process temperature shall not bring the enclosure of the electronics compartment beyond the specified ambient temperature range limits.
- When installing high or low temperature storage tank, heat or cold from the liquid, the vapor or tank wall should not be conducted to the NMS8x directly.
- Cover the tank with a thermal isolation material and/or install an ambient temperature adjustment pipe between NMS8x and nozzle of the tank.

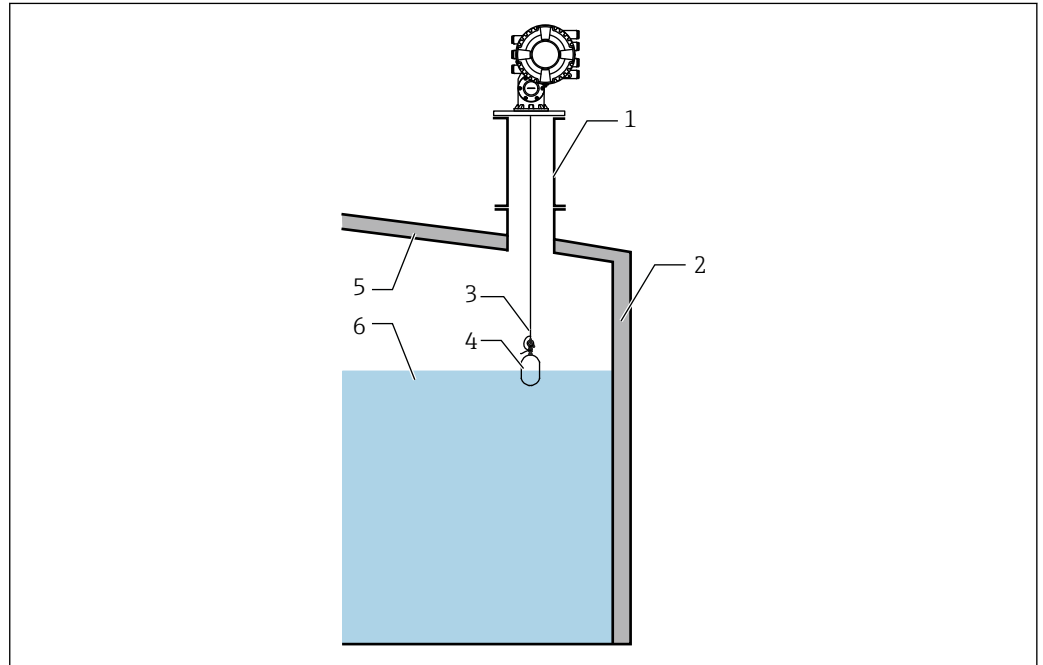

A0039927

- 1 Ambient temperature adjust pipe (optional)
- 2 Terminal isolation material
- 3 Measuring wire
- 4 Displacer
- 5 Tank wall
- 6 High or low temperature liquid

i The temperature of the flange and the internal temperature of the drum compartment:
 $-40\text{ °C} \leq T_a \leq +50, +55, \text{ or } +60\text{ °C}$ (see the table above.)

Applicable maximum installation height

Although IEC60079 series does not require contents of this section, the following is recommended to increase the safety when using this equipment. In the unlikely case that the displacer wire breaks and the displacer hits the tank bottom there is the possibility of an ignition if the potential energy stored in the displacer is greater than the minimum ignition energy. In order to avoid any ignition hazard the applicable maximum tank height (Hmax) which is depending on displacer weight (Wd) shall be as follows:

Ex group	Displacer weight		
	252 g (Standard)	270 g (Standard: Maximum)	300 g (Weight and Measure)
IIA	50.5 m (165.68 ft)	47.1 m (154.52 ft)47.1 m	42.4 m (139.1 ft)
IIB	50.5 m (165.68 ft)	47.1 m (154.52 ft)47.1 m	42.4 m (139.1 ft)
IIC	24.2 m (79.40 ft)	22.6 m (74.15 ft)	20.3 m (66.6 ft)

EN 13463-1:2009 clause 6.4.2.2.2 requirement of single impact energy limits for category 1G:

Gas group	Impact energy limit (E)
IIA	125 Nm
IIB	125 Nm
IIC	60 Nm

Calculation formula: $H_{max} = E / (Wd * 9.81)$

i In case of a tank gauge installation above the maximum height (Hmax), when the tank is empty and explosive gas/vapor is present, the displacer must be lowered to the tank bottom to avoid any ignition hazard between the displacer and the tank bottom.

Safety instructions: Zone 0

- In the event of potentially explosive vapor/air mixtures, only operate the device under atmospheric conditions.
 - Temperature: -20 to +60 °C
 - Pressure: 80 to 110 kPa (0.8 to 1.1 bar)
 - Air with normal oxygen content, usually 21 % (V/V)
- If no potentially explosive mixtures are present, or if additional protective measures have been taken, the device may also be operated under non-atmospheric conditions in accordance with the manufacturer's specifications.

Connection data

Connection compartment Ex d

Basic specification, Position 1, 2 (Approval) = BC, IC

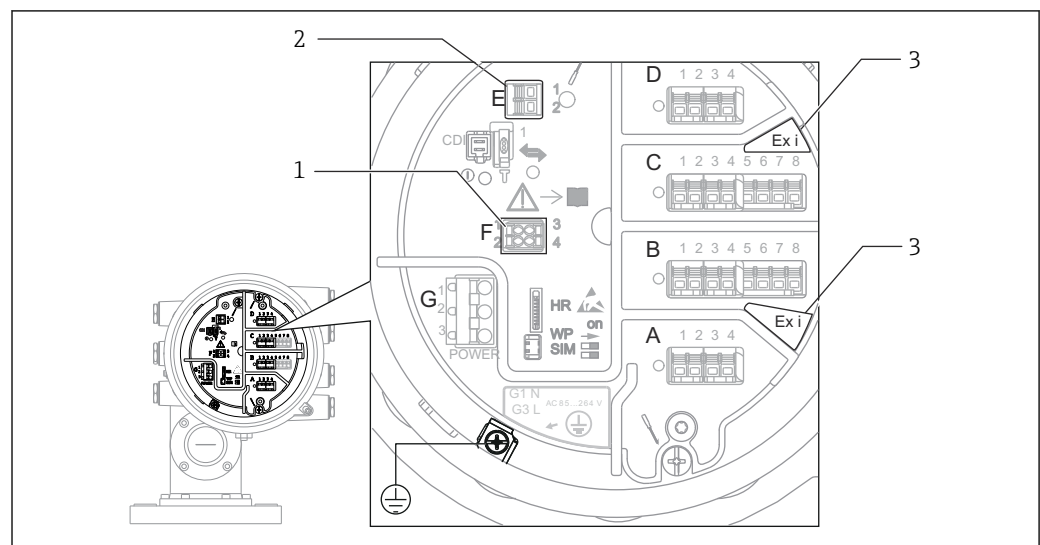

A0039928

- i** 1 Connection compartment Ex d
- 1 Connection for external display Ex i
- 2 Connection for HART interface Ex i
- 3 Only when "Analog Ex i" installed

TRC[01], type Power supply

Detailed configuration information located at the display holder.

Example for lettering:

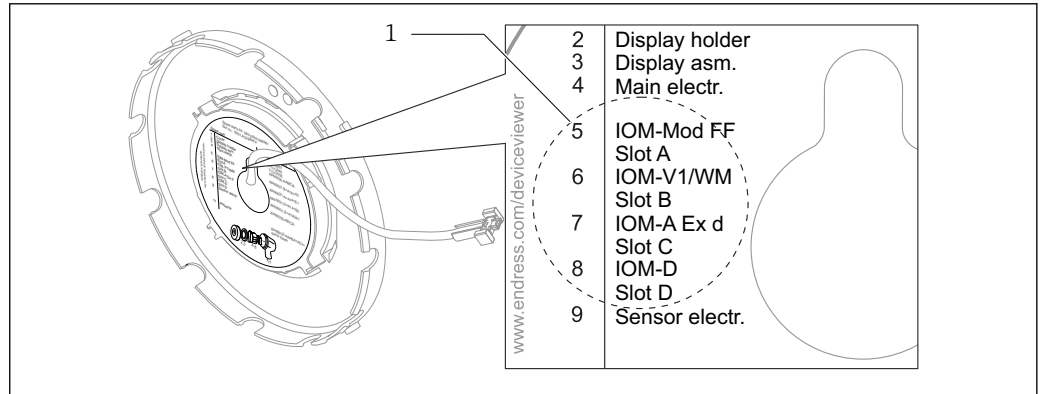

2

1 Area device configuration

i For detailed information see Operating Instructions.

i Assignment of the terminals see the designation of front plane.

Terminal	G	CDI
	Power supply: 85 to 264 V _{AC} 52 to 75 V _{AC} G1: N G2: not connected G3: L Power supply: 19 to 64 V _{DC} G1: L- G2: not connected G3: L+	plug connected
Designation	Power / Mains	Local LCD, CDI (internal)
non-Ex (functional)	Power supply: 85 to 264 V _{AC} U _N = 85 to 264 V _{AC} , 50/60 Hz P _N = 28.8 VA Power supply: 52 to 75 V _{AC} U _N = 52 to 75 V _{AC} , 50/60 Hz P _N = 21.6 VA Power supply: 19 to 64 V _{DC} U _N = 19 to 64 V _{DC} P _N = 13.4 W	U _N = 3.3 V _{DC} P _N = 41 mW

TRC[10], type Main board

Terminal	E	F
	E1: H+ E2: H-	F1: Vcc F2: A F3: B F4: gnd
Designation	4 to 20 mA HART	Remote display
Ex [ia]	$U_o = 29\text{ V}$ $I_o = 110\text{ mA}$ $P_o = 700\text{ mW}$ $C_o = 65\text{ nF}$ $L_o = 2.9\text{ mH}$	$U_o = 3.9\text{ V}$ $I_o = 500\text{ mA}$ $P_o = 230\text{ mW}$ $C_o = 99\text{ }\mu\text{F}$ $L_o = 140\text{ }\mu\text{H}$
non-Ex (functional)	$U_N = 24\text{ V}_{DC}$ $P_N \leq 426\text{ mW}$	$U_N = 3.3\text{ V}_{DC}$ $P_N = 41\text{ mW}$

TRC[32], type "Modbus" module; optional

Terminal	Slot A through slot D	
	1: S Cable shielding; capacitive connected to earth 2: 0V Common reference 3: B- Non-inverting signal line 4: A+ Inverting signal line	
Designation	Modbus-Slave	FOUNDATION Fieldbus
non-Ex (functional)	$U_N = 12\text{ V}_{DC}$ $P_N \leq 12\text{ mW}$ $U_M = 250\text{ V}$	Currently not supported

TRC[33], type "V1" module; optional

Terminal	Slot A through slot D	
	1: S Cable shielding; capacitive connected to earth 2: not connected 3: B- Signal - 4: A+ Signal +	
Designation	V1-Slave	WM550
non-Ex (functional)	$U_N = 24\text{ V}_{DC}$ $P_N \leq 414\text{ mW}$ $U_M = 250\text{ V}$	$U_N = 3.8\text{ V}_{DC}$ $P_N \leq 114\text{ mW}$ $U_M = 250\text{ V}$

TRC[20], type "Analog module" (Ex i); 4 to 20 mA HART; optional

Terminal	Slot B or slot C	
Operation mode: ■ 4 to 20 mA output or HART slave + 4 to 20 mA output or ■ 4 to 20 mA input or HART master + 4 to 20 mA input or ■ HART master	4-wire RTD connection: Terminal 5 through 8 3-wire RTD connection: Terminal 5, 6 and 8 2-wire RTD connection: Terminal 5 and 8	Terminal active use: 2: H- 3: H+
		Terminal passive use: 1: H- 2: H+
Designation	24 V + RTD	4 to 20 mA HART
Ex [ia]	Terminals 4-5 (24 V): $U_o = 29\text{ V}$ $I_o = 108\text{ mA}$ $P_o = 776\text{ mW}$ $C_o = 63\text{ nF}$ $L_o = 3.0\text{ mH}$	Terminals 2-3 (Active): $U_o = 29\text{ V}$ $I_o = 106\text{ mA}$ $P_o = 760\text{ mW}$ $C_o = 63\text{ nF}$ $L_o = 3.1\text{ mH}$
	Terminals 5-8 (RTD): $U_o = 29\text{ V}$ $I_o = 36\text{ mA}$ $P_o = 263\text{ mW}$ $C_o = 64\text{ nF}$ $L_o = 26\text{ mH}$	Terminals 1-2 (Passive): $U_i = 29\text{ V}$ $I_i = 106\text{ mA}$ $P_i = 760\text{ mW}$ $C_i = 11\text{ nF}$ $L_i = 0$
non-Ex (functional)	Terminals 4-5 (24 V): $U_N = 24\text{ V}_{DC}$ $P_N \leq 600\text{ mW}$	Terminals 2-3 (Active): $U_N = 24\text{ V}_{DC}$ $P_N \leq 540\text{ mW}$
	Terminals 5-8 (RTD): $I_N = 400\text{ }\mu\text{A}_{DC}$ $P_N \leq 160\text{ }\mu\text{W}$	Terminals 1-2 (Passive): $U_N = 29\text{ V}_{DC}$ $P_N \leq 653\text{ mW}$

TRC[21], type "Analog module" (Ex d); 4 to 20 mA HART; optional

Terminal	Slot B or slot C	
Operation mode: ■ 4 to 20 mA output or HART slave + 4 to 20 mA output or ■ 4 to 20 mA input or HART master + 4 to 20 mA input or ■ HART master	4-wire RTD connection: Terminal 5 through 8 3-wire RTD connection: Terminal 5, 6 and 8 2-wire RTD connection: Terminal 5 and 8	Terminal active use: 2: H- 3: H+
		Terminal passive use: 1: H- 2: H+
Designation	24 V + RTD	4 to 20 mA HART
non-Ex (functional)	Terminals 4-5 (24 V): not used	Terminals 2-3 (Active): $U_N = 24\text{ V}_{DC}$ $P_N \leq 540\text{ mW}$ $U_M = 250\text{ V}$
	Terminals 5-8 (RTD): $I_N = 400\text{ }\mu\text{A}_{DC}$ $P_N \leq 160\text{ }\mu\text{W}$ $U_M = 250\text{ V}$	Terminals 1-2 (Passive): $U_N = 29\text{ V}_{DC}$ $P_N \leq 653\text{ mW}$ $U_M = 250\text{ V}$

TRC[31], type "Digital"; optional

Terminal	Slot A through slot D	
Operation mode: <ul style="list-style-type: none"> ■ disabled ■ passive output ■ passive input ■ active input 	Installed in slot A:	
	1: A1-1 2: A1-2	3: A2-1 4: A2-2
	Installed in slot B:	
	1: B1-1 2: B1-2	3: B2-1 4: B2-2
Installed in slot C:		
	1: C1-1 2: C1-2	3: C2-1 4: C2-2
Installed in slot D:		
	1: D1-1 2: D1-2	3: D2-1 4: D2-2
Designation	Relay / Digital Input/Output 1	Relay / Digital Input/Output 2
non-Ex (functional)	Relay: $U_N = 250 V_{AC/DC}$ $I_N \leq 2 A$	Relay: $U_N = 250 V_{AC/DC}$ $I_N \leq 2 A$
	Digital Input: $U_N = 5 \text{ to } 230 V_{AC/DC}$ $U_M = 250 V$	Digital Input: $U_N = 5 \text{ to } 230 V_{AC/DC}$ $U_M = 250 V$



www.addresses.endress.com
