

Operating Instructions

Levelflex FMP53

HART

Guided-wave radar

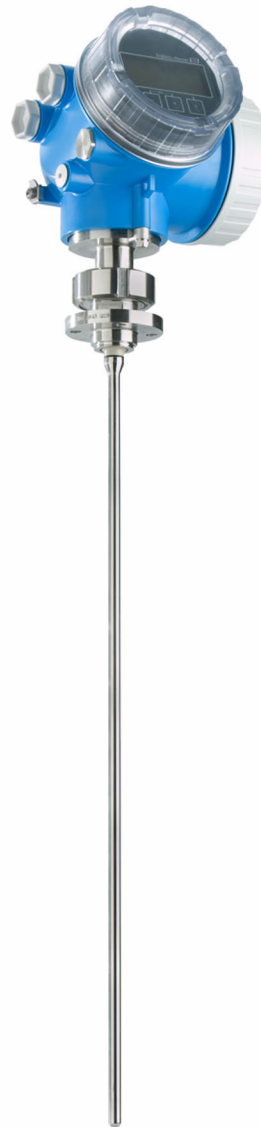

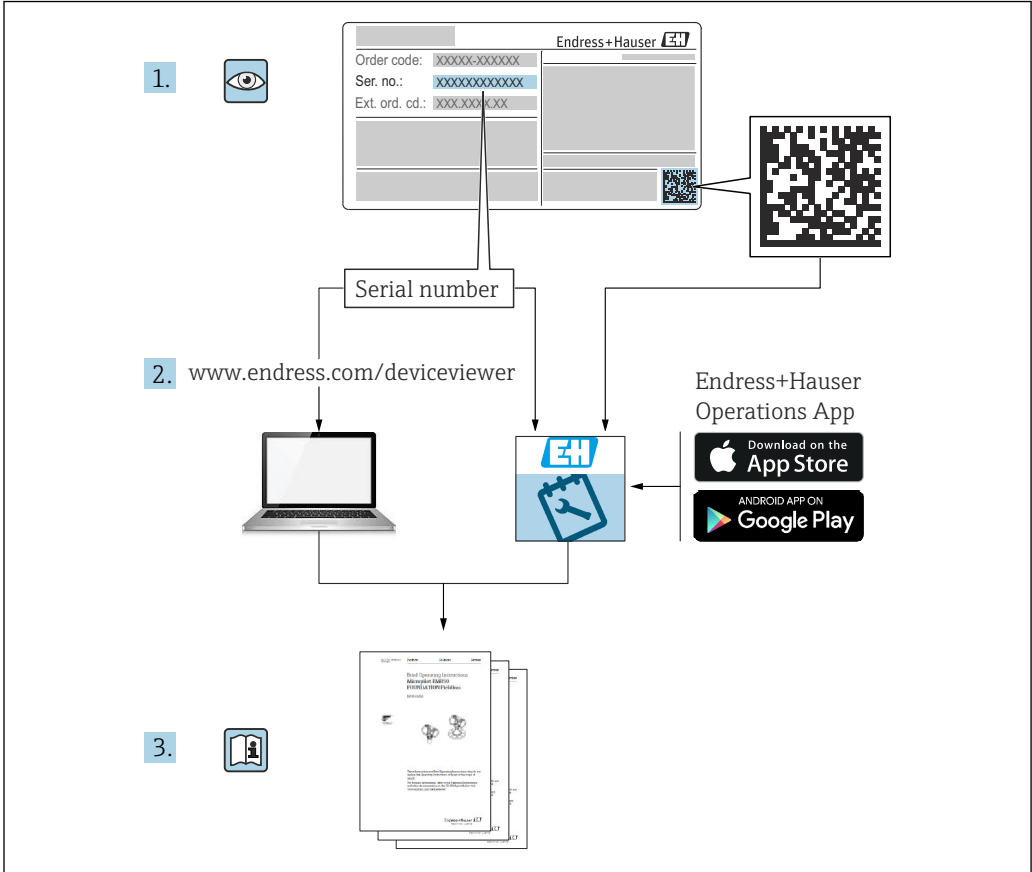

A0023555

Table of contents

1	About this document	5	7	Electrical connection	28
1.1	Document function	5	7.1	Connecting requirements	28
1.2	Symbols	5	7.1.1	Terminal assignment	28
1.2.1	Safety symbols	5	7.1.2	Cable specification	32
1.2.2	Electrical symbols	5	7.1.3	Device plug	32
1.2.3	Tool symbols	5	7.1.4	Supply voltage	34
1.2.4	Symbols for certain types of information and graphics	6	7.1.5	Overvoltage protection	35
1.3	List of abbreviations	6	7.2	Connecting the device	36
1.4	Documentation	7	7.2.1	Opening cover	36
1.5	Registered trademarks	8	7.2.2	Connecting	37
2	Basic safety instructions	9	7.2.3	Plug-in spring-force terminals	37
2.1	Requirements for the personnel	9	7.2.4	Closing the cover of the connection compartment	38
2.2	Intended use	9	7.3	Post-connection check	38
2.3	Workplace safety	10	8	Operation options	39
2.4	Operational safety	10	8.1	Overview of operation options	39
2.5	Product security	10	8.1.1	Access to operating menu via local display	39
2.5.1	CE mark	10	8.1.2	Access to the operating menu via the operating tool	40
2.5.2	EAC conformity	11	8.2	Structure and function of the operating menu	41
3	Product description	12	8.2.1	Structure of the operating menu	41
3.1	Product design	12	8.2.2	User roles and related access authorization	42
3.1.1	Levelflex FMP53	12	8.2.3	Data access - Security	43
3.1.2	Electronics housing	13	8.3	Display and operating module	47
4	Incoming acceptance and product identification	14	8.3.1	Display format	47
4.1	Incoming acceptance	14	8.3.2	Operating elements	49
4.2	Product identification	14	8.3.3	Entering numbers and text	50
4.2.1	Nameplate	14	8.3.4	Opening the context menu	52
4.2.2	Manufacturer address	15	8.3.5	Envelope curve display on the display and operating module	53
5	Storage, transport	16	9	System integration	54
5.1	Storage temperature	16	9.1	Overview of the device description files	54
5.2	Transporting to the measuring point	16	9.2	Measured variables via HART protocol	54
6	Installation	17	10	Commissioning via SmartBlue (App)	55
6.1	Mounting requirements	17	10.1	Operation via Bluetooth® wireless technology (optional)	55
6.1.1	Suitable mounting position	17	10.1.1	Operation via SmartBlue App	55
6.1.2	Mounting under confined conditions	18	10.2	Envelope curve display in SmartBlue	56
6.1.3	Notes on the mechanical load of the probe	19	11	Commissioning using the wizard ...	57
6.1.4	Special installation situations	20	12	Commissioning via operating menu	58
6.2	Mounting the device	24	12.1	Installation and function check	58
6.2.1	Tool list	24			
6.2.2	Mounting the "Sensor, remote" version	24			
6.2.3	Turning the transmitter housing	25			
6.2.4	Turning the display	26			
6.3	Post-mounting check	27			

12.2	Configuring the operating language	58	16.1.5	Calibration kit	82
12.3	Configuring level measurement	59	16.1.6	Remote display FHX50	82
12.4	Recording the reference echo curve	60	16.1.7	Overvoltage protection	83
12.5	Configuring the local display	60	16.1.8	Bluetooth module BT10 for HART devices	84
	12.5.1 Factory setting of local display for level measurements	60	16.2	Communication-specific accessories	85
	12.5.2 Adjusting the local display	60	16.3	Service-specific accessories	86
12.6	Configuring the current outputs	61	16.4	System components	86
	12.6.1 Factor setting of current outputs for level measurements	61	16.4.1	Memograph M RSG45	86
	12.6.2 Adjusting the current outputs	61	16.4.2	RN42	86
12.7	Configuration management	61	17	Operating menu	87
12.8	Protecting settings from unauthorized access .	62	17.1	Overview of the operating menu (SmartBlue) .	87
13	Diagnostics and troubleshooting	63	17.2	Overview of the operating menu (display module)	92
13.1	General troubleshooting	63	17.3	Overview of the operating menu (operating tool)	99
	13.1.1 General errors	63	17.4	"Setup" menu	106
	13.1.2 Error - SmartBlue operation	64	17.4.1	"Mapping" wizard	113
	13.1.3 Parameter configuration errors	64	17.4.2	"Advanced setup" submenu	114
13.2	Diagnostic information on local display	65	17.5	"Diagnostics" menu	162
	13.2.1 Diagnostic message	65	17.5.1	"Diagnostic list" submenu	164
	13.2.2 Calling up remedial measures	67	17.5.2	"Event logbook" submenu	165
13.3	Diagnostic event in the operating tool	67	17.5.3	"Device information" submenu	166
13.4	Diagnostic list	69	17.5.4	"Measured values" submenu	169
13.5	List of diagnostic events	70	17.5.5	"Data logging" submenu	171
13.6	Event logbook	72	17.5.6	"Simulation" submenu	174
	13.6.1 Event history	72	17.5.7	"Device check" submenu	179
	13.6.2 Filtering the event logbook	72	17.5.8	"Heartbeat" submenu	181
	13.6.3 Overview of information events	72	Index	182	
13.7	Firmware history	73			
14	Maintenance	75			
14.1	Exterior cleaning	75			
14.2	General cleaning instructions	75			
14.3	Cleaning the probe	75			
	14.3.1 Cleaning the probe in the vessel	75			
	14.3.2 Cleaning the probe outside the vessel	75			
15	Repair	77			
15.1	General information	77			
	15.1.1 Repair concept	77			
	15.1.2 Repairs to Ex-approved devices	77			
	15.1.3 Replacing electronics modules	77			
	15.1.4 Replacing a device	77			
15.2	Spare parts	78			
15.3	Return	78			
15.4	Disposal	78			
16	Accessories	79			
16.1	Device-specific accessories	79			
	16.1.1 Weather protection cover	79			
	16.1.2 Mounting bracket for electronics housing	80			
	16.1.3 Weld-in adapter	81			
	16.1.4 Protective cover	81			

1 About this document

1.1 Document function

These Operating Instructions contain all the information required in the various life cycle phases of the device: from product identification, incoming acceptance and storage, to installation, connection, operation and commissioning, through to troubleshooting, maintenance and disposal.

1.2 Symbols

1.2.1 Safety symbols

 DANGER

This symbol alerts you to a dangerous situation. Failure to avoid this situation will result in serious or fatal injury.

 WARNING

This symbol alerts you to a potentially dangerous situation. Failure to avoid this situation can result in serious or fatal injury.





 CAUTION

This symbol alerts you to a potentially dangerous situation. Failure to avoid this situation can result in minor or medium injury.

NOTICE

This symbol alerts you to a potentially harmful situation. Failure to avoid this situation can result in damage to the product or something in its vicinity.

1.2.2 Electrical symbols

Symbol	Meaning
	Direct current
	Alternating current
	Direct and alternating current
	Ground connection A grounded terminal which, as far as the operator is concerned, is grounded via a grounding system.
	Protective earth (PE) Ground terminals that must be connected to ground prior to establishing any other connections. The ground terminals are located on the interior and exterior of the device: <ul style="list-style-type: none"> ▪ Interior ground terminal: protective earth is connected to the mains supply. ▪ Exterior ground terminal: device is connected to the plant grounding system.

1.2.3 Tool symbols

 Phillips head screwdriver

 Flat blade screwdriver

 Torx screwdriver



Allen key



Open-ended wrench

1.2.4 Symbols for certain types of information and graphics

 **Permitted**

Procedures, processes or actions that are permitted

  **Preferred**

Procedures, processes or actions that are preferred

 **Forbidden**

Procedures, processes or actions that are forbidden

 **Tip**

Indicates additional information



Reference to documentation



Reference to graphic



Notice or individual step to be observed

1, 2, 3

Series of steps



Result of a step



Visual inspection



Operation via operating tool



Write-protected parameter

1, 2, 3, ...

Item numbers

A, B, C, ...

Views

  **Safety instructions**

Observe the safety instructions contained in the associated Operating Instructions



Temperature resistance of the connection cables

Specifies the minimum value of the temperature resistance of the connection cables

1.3 List of abbreviations

BA

Document type "Operating Instructions"

KA

Document type "Brief Operating Instructions"

TI

Document type "Technical Information"

SD

Document type "Special Documentation"

XA

Document type "Safety Instructions"

PN

Nominal pressure

MWP

Maximum working pressure

The MWP is indicated on the nameplate.

ToF

Time of Flight

FieldCare

Scalable software tool for device configuration and integrated plant asset management solutions

DeviceCare

Universal configuration software for Endress+Hauser HART, PROFIBUS, FOUNDATION Fieldbus and Ethernet field devices

DTM

Device Type Manager

DD

Device Description for HART communication protocol

 ϵ_r (Dk value)

Relative dielectric constant

PLC

Programmable logic controller (PLC)

CDI

Common Data Interface

Operating tool

The term "operating tool" is used in place of the following operating software:

- FieldCare / DeviceCare, for operation via HART communication and PC
- SmartBlue app, for operation using an Android or iOS smartphone or tablet

BD

Blocking Distance; no signals are analyzed within the BD.

PLC

Programmable logic controller (PLC)

CDI

Common Data Interface

PFS

Pulse Frequency Status (Switch output)

1.4 Documentation



For an overview of the scope of the associated Technical Documentation, refer to the following:

- *Device Viewer* (www.endress.com/deviceviewer): Enter the serial number from the nameplate
- *Endress+Hauser Operations app*: Enter serial number from nameplate or scan matrix code on nameplate.

The following documentation may be available depending on the device version ordered:

Document type	Purpose and content of the document
Technical Information (TI)	Planning aid for your device The document contains all the technical data on the device and provides an overview of the accessories and other products that can be ordered for the device.
Brief Operating Instructions (KA)	Guide that takes you quickly to the 1st measured value The Brief Operating Instructions contain all the essential information from incoming acceptance to initial commissioning.
Operating Instructions (BA)	Your reference document These Operating Instructions contain all the information that is required in the various life cycle phases of the device: from product identification, incoming acceptance and storage, to mounting, connection, operation and commissioning, through to troubleshooting, maintenance and disposal.
Description of Device Parameters (GP)	Reference for your parameters The document provides a detailed explanation of each individual parameter. The description is aimed at those who work with the device over the entire life cycle and perform specific configurations.
Safety Instructions (XA)	Depending on the approval, safety instructions for electrical equipment in hazardous areas are also supplied with the device. The Safety Instructions are a constituent part of the Operating Instructions.  Information on the Safety Instructions (XA) that are relevant for the device is provided on the nameplate.
Supplementary device-dependent documentation (SD/FY)	Always comply strictly with the instructions in the relevant supplementary documentation. The supplementary documentation is a constituent part of the device documentation.

1.5 Registered trademarks

HART®

Registered trademark of the FieldComm Group, Austin, Texas, USA

Bluetooth®

The *Bluetooth*® word mark and logos are registered trademarks owned by the Bluetooth SIG, Inc. and any use of such marks by Endress+Hauser is under license. Other trademarks and trade names are those of their respective owners.

Apple®

Apple, the Apple logo, iPhone, and iPod touch are trademarks of Apple Inc., registered in the U.S. and other countries. App Store is a service mark of Apple Inc.

Android®

Android, Google Play and the Google Play logo are trademarks of Google Inc.

KALREZ®, VITON®

Registered trademarks of DuPont Performance Elastomers L.L.C., Wilmington, DE USA

TEFLON®

Registered trademark of E.I. DuPont de Nemours & Co., Wilmington, USA

TRI-CLAMP®

Registered trademark of Ladish & Co., Inc., Kenosha, USA

2 Basic safety instructions

2.1 Requirements for the personnel

The personnel for installation, commissioning, diagnostics and maintenance must fulfill the following requirements:

- ▶ Trained, qualified specialists must have a relevant qualification for this specific function and task.
- ▶ Are authorized by the plant owner/operator.
- ▶ Are familiar with federal/national regulations.
- ▶ Before starting work, read and understand the instructions in the manual and supplementary documentation as well as the certificates (depending on the application).
- ▶ Follow instructions and comply with basic conditions.

The operating personnel must fulfill the following requirements:

- ▶ Are instructed and authorized according to the requirements of the task by the facility's owner-operator.
- ▶ Follow the instructions in this manual.

2.2 Intended use

Application and media

The measuring instrument described in this manual is intended only for the level measurement of liquids. Depending on the version ordered, the measuring instrument can also measure potentially explosive, flammable, poisonous and oxidizing media.

If the limit values specified in the "Technical data" and the conditions listed in the instructions and additional documentation are observed, the measuring instrument may be used only for the following measurements:

- ▶ Measured process variables: level
- ▶ Calculable process variables: volume or mass in any shape of vessel (calculated from the level by the linearization functionality)

To ensure that the measuring instrument remains in proper condition for the operation time:

- ▶ Use the measuring instrument only for media to which the process-wetted materials are sufficiently resistant.
- ▶ Observe the limit values in the "Technical data".

Incorrect use

The manufacturer is not liable for harm caused by improper or unintended use.

Clarification for borderline cases:

- ▶ For special fluids and fluids for cleaning, Endress+Hauser is glad to provide assistance in verifying the corrosion resistance of fluid-wetted materials, but does not accept any warranty or liability.

Residual risks

Due to heat transfer from the process as well as power loss in the electronics, the temperature of the electronics housing and the assemblies contained therein (e.g. display module, main electronics module and I/O electronics module) may rise up to 80 °C (176 °F). When in operation, the sensor may reach a temperature close to the medium temperature.

Danger of burns from contact with surfaces!

- ▶ In the event of elevated fluid temperatures, ensure protection against contact to prevent burns.

2.3 Workplace safety

When working on and with the device:

- ▶ Wear the required personal protective equipment as per national regulations.

With separable probe rods, medium may penetrate the joints between the individual parts of the rod. This medium may escape when the joints are loosened. This can cause injuries in the case of dangerous (e.g., aggressive or toxic) media.

- ▶ When loosening the joints between the individual parts of the probe rod, wear appropriate protective equipment according to the medium.

2.4 Operational safety

Risk of injury!

- ▶ Operate the device only if it is in proper technical condition, free from errors and faults.
- ▶ The operator is responsible for ensuring that the device is in good working order.

Modifications to the device

Unauthorized modifications to the device are not permitted and can lead to unforeseeable dangers:

- ▶ If modifications are nevertheless required, consult with the manufacturer.

Repair

To ensure continued operational safety and reliability:

- ▶ Carry out repairs on the device only if they are expressly permitted.
- ▶ Observe national regulations pertaining to the repair of an electrical device.
- ▶ Use only original spare parts and accessories from the manufacturer.

Hazardous area

To eliminate danger to persons or the installation when the device is used in the hazardous area (e.g. explosion protection, pressure vessel safety):

- ▶ Check the nameplate to verify if the device ordered can be put to its intended use in the hazardous area.
- ▶ Observe the specifications in the separate supplementary documentation included as an integral part of these instructions.

2.5 Product security

This measuring instrument is designed in accordance with good engineering practice to meet state-of-the-art safety requirements, has been tested, and left the factory in a condition in which it is safe to operate. It meets general safety standards and legal requirements.

NOTICE

Loss of degree of protection by opening of the device in humid environments

- ▶ If the device is opened in a humid environment, the degree of protection indicated on the nameplate is no longer valid. This may also impair the safe operation of the device.

2.5.1 CE mark

The measuring system meets the legal requirements of the applicable EU directives. These are listed in the corresponding EU Declaration of Conformity together with the standards applied.

The manufacturer confirms successful testing of the device by affixing to it the CE mark.

2.5.2 EAC conformity

The measuring system meets the legal requirements of the applicable EAC guidelines. These are listed in the corresponding EAC Declaration of Conformity along with the standards applied.

The manufacturer confirms successful testing of the device by affixing to it the EAC mark.

3 Product description

3.1 Product design

3.1.1 Levelflex FMP53

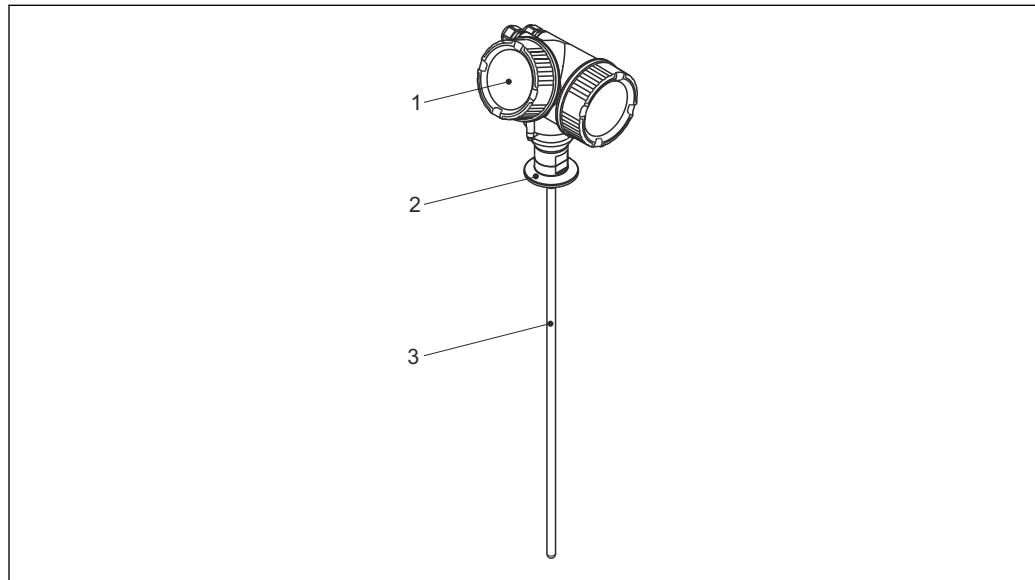

A0013421

1 Design of the Levelflex

- 1 Electronics housing
- 2 Process connection
- 3 Rod probe

3.1.2 Electronics housing

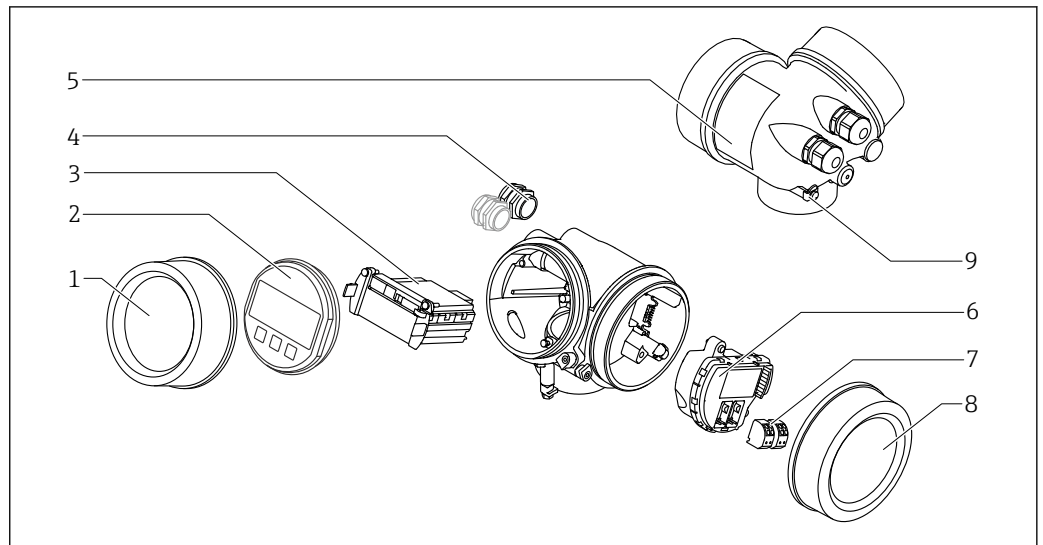

A0012422

2 Design of the electronics housing

- 1 Electronics compartment cover
- 2 Display module
- 3 Main electronics module
- 4 Cable glands (1 or 2, depending on instrument version)
- 5 Nameplate
- 6 I/O electronics module
- 7 Terminals (pluggable spring terminals)
- 8 Connection compartment cover
- 9 Grounding terminal

4 Incoming acceptance and product identification

4.1 Incoming acceptance

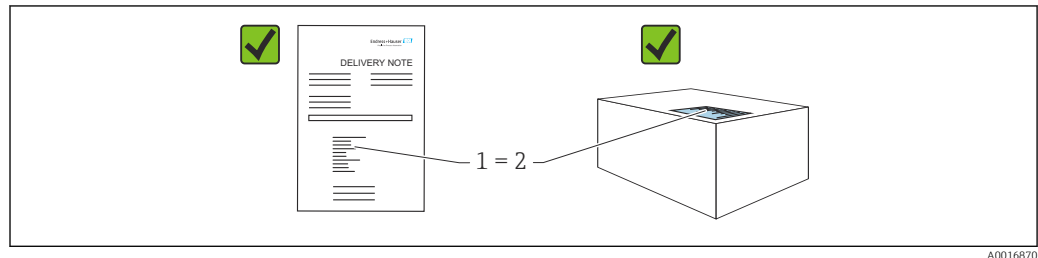

Check the following during incoming acceptance:

- Is the order code on the delivery note (1) identical to the order code on the product sticker (2)?
- Are the goods undamaged?
- Do the data on the nameplate correspond to the order specifications and the delivery note?
- Is the documentation provided?
- If required (see nameplate): are the Safety Instructions (XA) provided?



If one of these conditions is not met, please contact the manufacturer's sales office.

4.2 Product identification

The following options are available for identification of the device:

- Nameplate specifications
- Extended order code with breakdown of the device features on the delivery note
- ▶ *Device Viewer* (www.endress.com/deviceviewer); manually enter the serial number from the nameplate.
 - ↳ All the information about the measuring device is displayed.
- ▶ *Endress+Hauser Operations app*; manually enter the serial number indicated on the nameplate or scan the 2D matrix code on the nameplate.
 - ↳ All the information about the measuring device is displayed.

4.2.1 Nameplate

The information that is required by law and is relevant to the device is shown on the nameplate, e.g.:

- Manufacturer identification
- Order number, extended order code, serial number
- Technical data, degree of protection
- Firmware version, hardware version
- Approval-related information, reference to Safety Instructions (XA)
- DataMatrix code (information about the device)

4.2.2 Manufacturer address

Endress+Hauser SE+Co. KG
Hauptstraße 1
79689 Maulburg, Germany
Place of manufacture: See nameplate.

5 Storage, transport

5.1 Storage temperature

- Permitted storage temperature: -40 to +80 °C (-40 to +176 °F)
- Use original packaging.

5.2 Transporting to the measuring point

⚠ WARNING

Housing or probe may become damaged or break off.

Risk of injury!

- ▶ Transport the measuring instrument to the measuring point in its original packaging or by the process connection.
- ▶ Always secure lifting equipment (slings, eyes, etc.) at the process connection and never lift the device by the electronic housing or probe. Pay attention to the center of gravity of the device so that it does not tilt or slip unintentionally.
- ▶ Follow the safety instructions and transport conditions for devices weighing more than 18 kg (39.6 lbs) (IEC 61010).

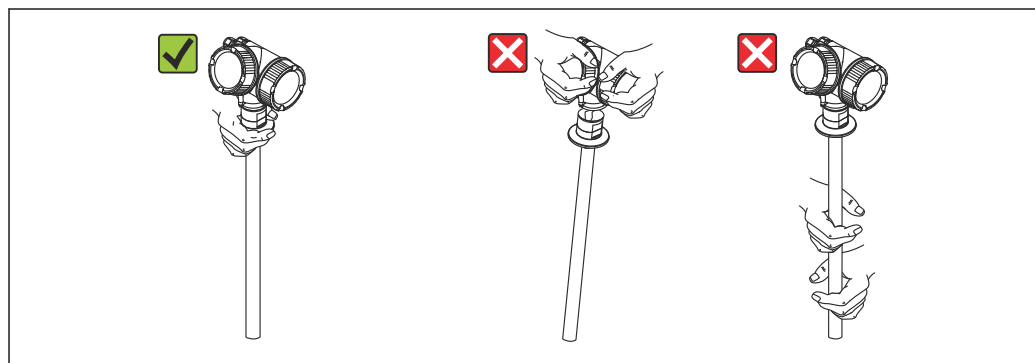

A0014267

6 Installation

6.1 Mounting requirements

6.1.1 Suitable mounting position

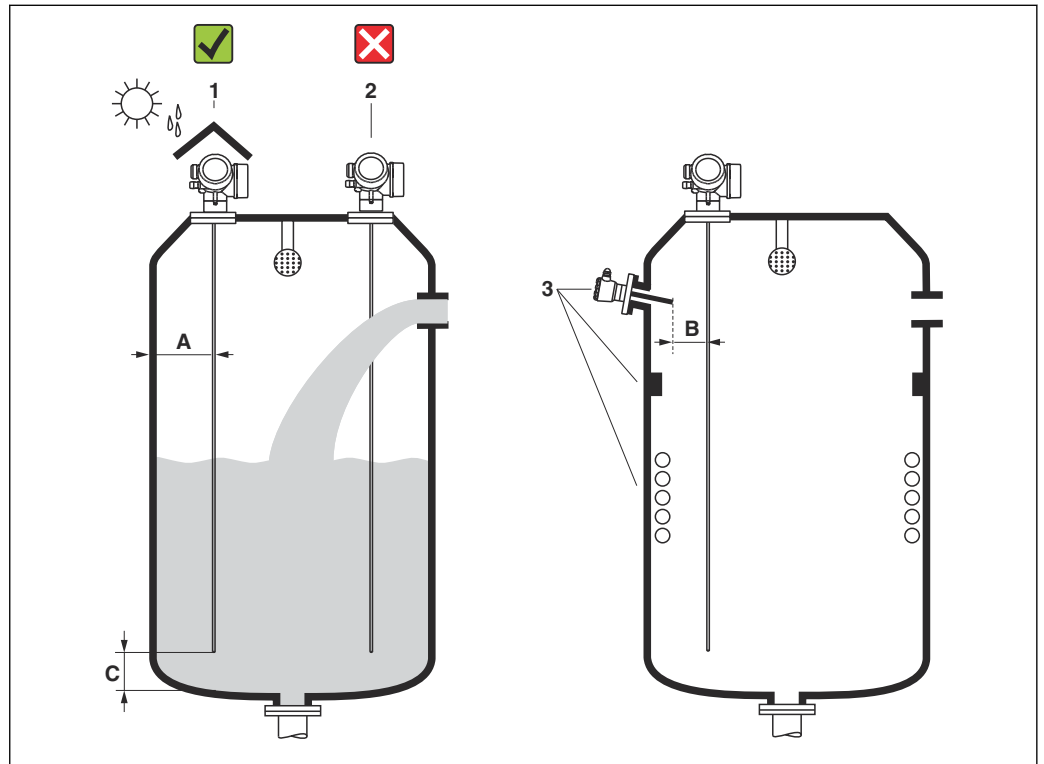

3 Installation positions

A0014130

Spacing requirements when mounting

- Distance (A) between the vessel wall and rod probes:
 - For smooth metallic walls: > 50 mm (2 in)
 - For plastic walls: > 300 mm (12 in) to metallic parts outside the vessel
- Distance (B) between rod probes and internal fittings (4): > 300 mm (12 in)
- When using more than one Levelflex:
 - Minimum distance between the sensor axes: 100 mm (3.94 in)
- Distance (C) from the end of the probe to the bottom of the vessel: > 10 mm (0.4 in)

Additional mounting requirements

- When mounting outdoors, a weather protection cover (1) can be used to protect the device against extreme weather conditions.
- Do not mount the probe in the filling curtain (2).

i When mounting the housing in a recess (e.g. in a concrete ceiling), observe a minimum distance of 100 mm (4 in) between the cover of the connection compartment/electronics compartment and the wall. Otherwise the connection compartment/electronics compartment will not be accessible after installation.

6.1.2 Mounting under confined conditions

Mounting with remote probe

The device version with a remote probe is suitable for applications with restricted mounting space (product structure: probe design). In this case, the electronics housing is mounted at a separate position from the probe.

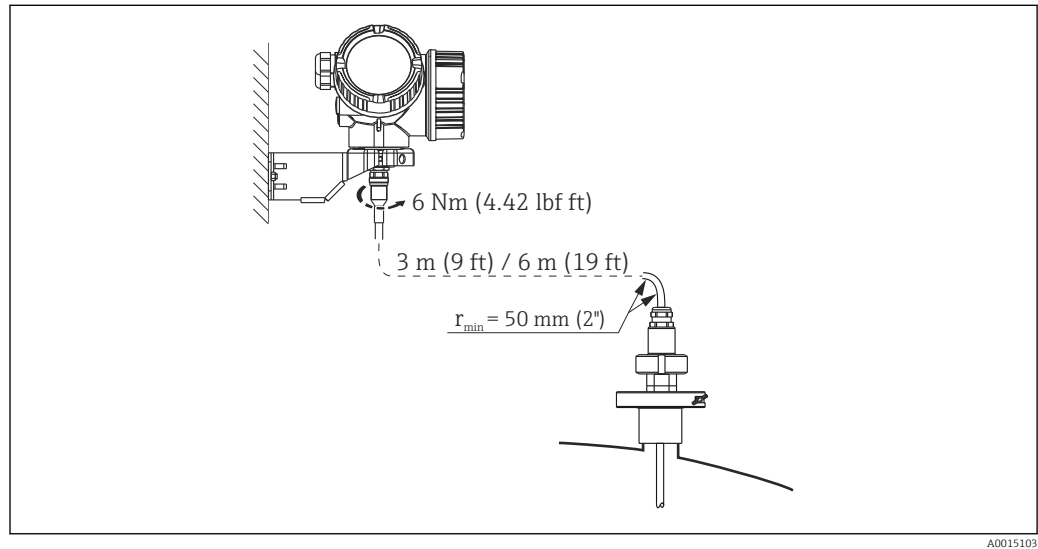

A0015103

- The connecting cable is connected to the probe upon delivery.
 - Length: 3 m (9 ft) or 6 m (18 ft)
 - Minimum bending radius: 50 mm (2 inch)
- The mounting bracket for the electronics housing is included in the delivery with this version. Mounting options:
 - Wall mounting
 - Mounting on DN32 to DN50 (1¼ to 2 inch) post or pipe

i The probe with the connection cable and the electronics are mutually compatible and bear a common serial number. Only components with the same serial number may be connected to one another.

Separable probes

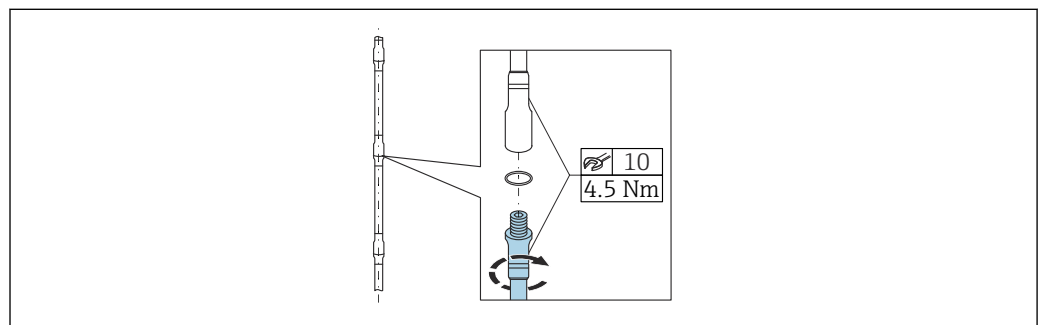

A0014166

In confined mounting conditions (ceiling clearance), the use of separable rod probe ($\varnothing 8 \text{ mm}$) is advisable.

- Max. probe length 4 m (13.12 ft)
- Max. lateral loading capacity 10 Nm
- Probes can be separated several times, with the individual parts having the following lengths:
 - 500 mm (20 in)
 - 1 000 mm (40 in)
- The connection points are sealed gap-free by an O-ring.

i Mounting instructions

- Use fitting pliers with a plastic surface to avoid damage.
- Install the separable rods in a vertical position.
- Align the rods with each other so that the threads do not tilt.

6.1.3 Notes on the mechanical load of the probe

Lateral loading capacity (flexural strength) of rod probes

FMP53

Rod 8 mm (0.31 in) 316L

Flexural strength 10 Nm

Rod 8 mm (0.31 in) 316 L separable

Flexural strength 10 Nm

Lateral load (bending moment) from flow conditions

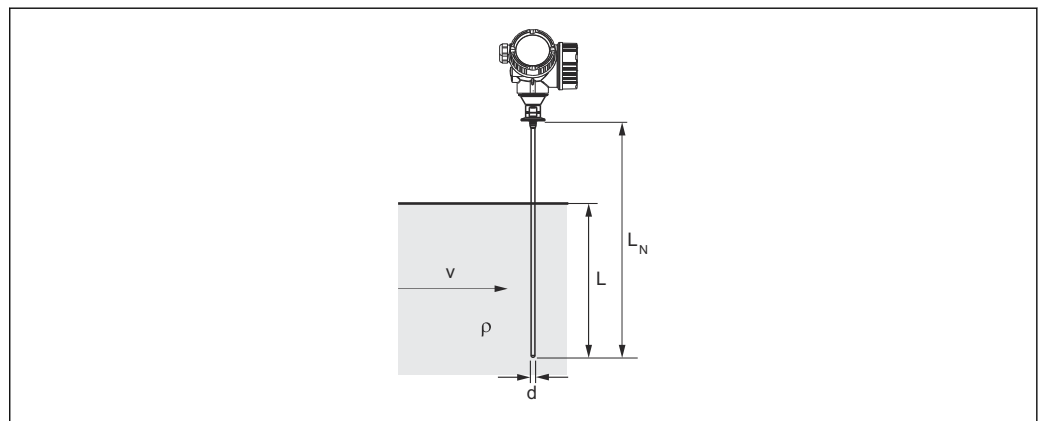

A0014175

- ρ Density of the medium [kg/m³]
- v Flow velocity [m/s] of the medium, perpendicular to the probe rod
- d Diameter [m] of probe rod
- L Level [m]
- L_N Probe length [m]

The formula for calculating the bending moment M acting on the probe:

$$M = c_w \times \rho / 2 \times v^2 \times d \times L \times (L_N - 0.5 \times L)$$

With:

c_w : coefficient of friction

Sample calculation

Coefficient of friction c_w	0.9 (assuming turbulent flow - high Reynolds number)
Density ρ [kg/m ³]	1000 (e.g. water)
Probe diameter d [m]	0.008
$L = L_N$	(unfavorable conditions)

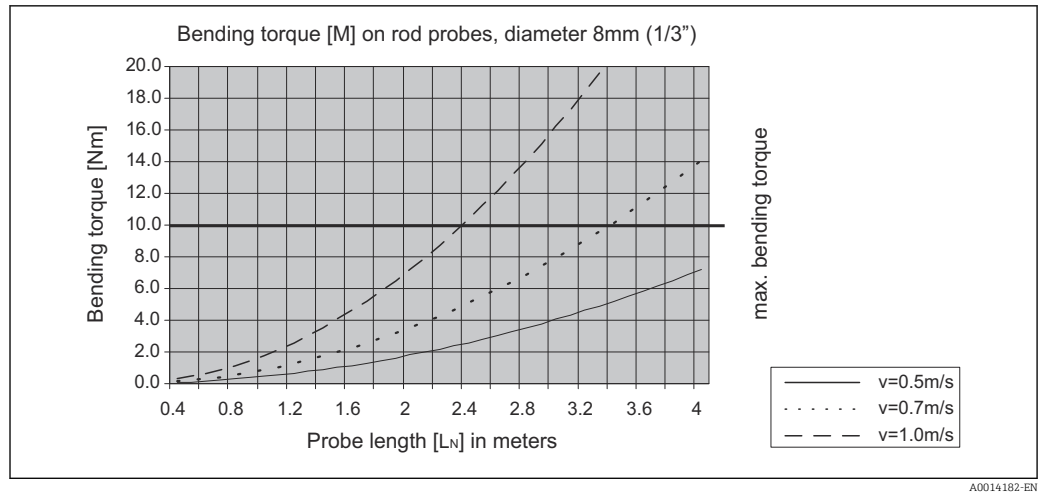

6.1.4 Special installation situations

Tanks with spray ball for probe cleaning

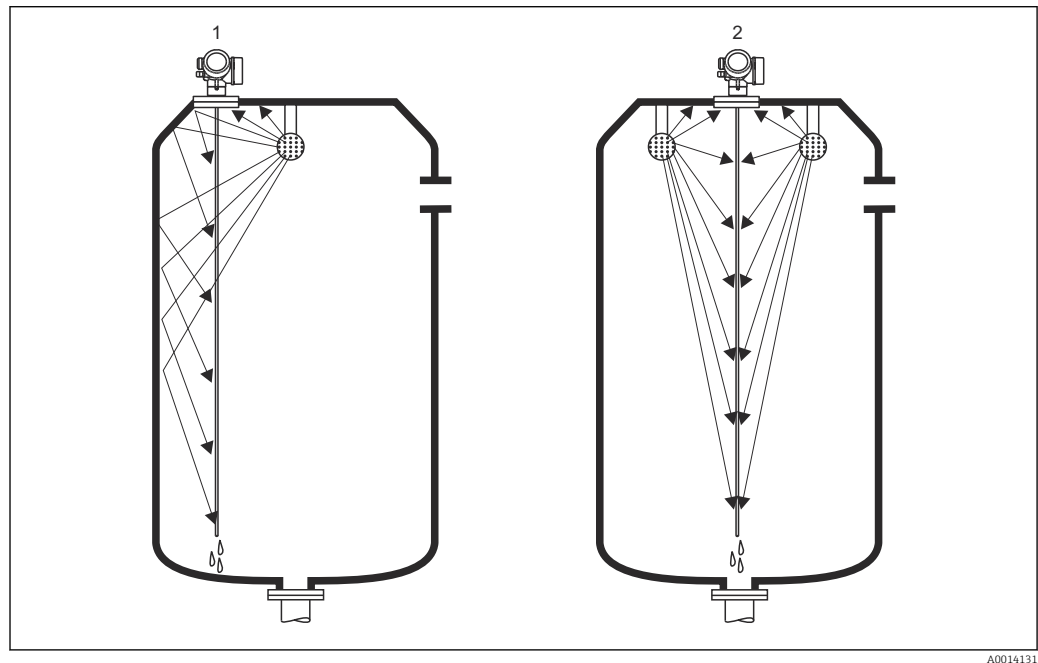

Mounting close to vessel wall

Mounting the probe close to the vessel wall improves the cleaning effect when a spray ball is used. The cleaning jet is directed onto the probe via the vessel wall. As a result, the probe is also cleaned in places the spray ball jet would normally not reach. You only require one spray ball for this probe arrangement.

Mounting in the center of the vessel

If the probe is mounted in the center of the vessel, the use of a second spray ball may be necessary. These balls should then be mounted to the left and right of the probe.

Mounting at an angle

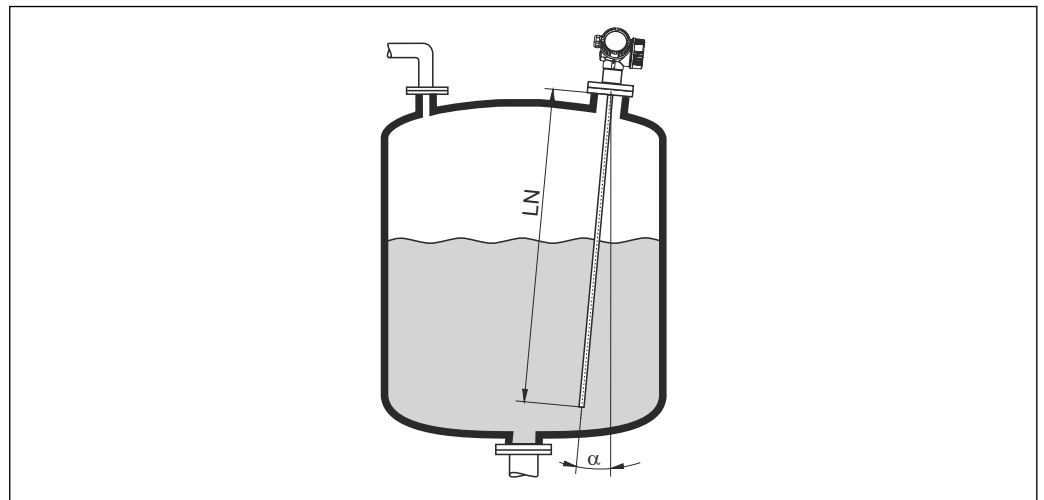

A0014145

- For mechanical reasons, the probe should be installed as vertically as possible.
- If the probe is installed at an angle, the length of the probe must be reduced depending on the angle of installation.
 - α 5°: LN_{max} . 4 m (13.1 ft)
 - α 10°: LN_{max} . 2 m (6.6 ft)
 - α 30°: LN_{max} . 1 m (3.3 ft)

Non-metal vessels

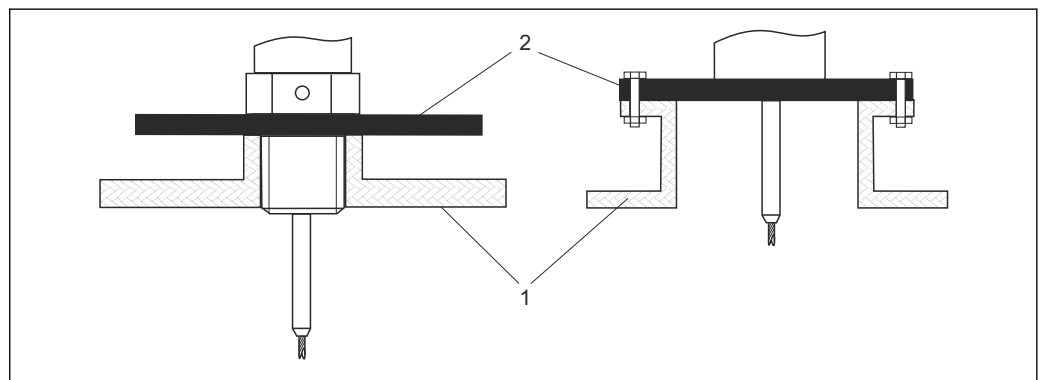

A0012527

- 1 Non-metal vessel
- 2 Metal sheet or metal flange

To ensure good measurement results when mounting on non-metal vessels, at the process connection mount a metal sheet with a diameter of at least 200 mm (8 in) at a right angle to the probe.

Plastic and glass vessels: Mounting the probe on the outside wall

In the case of plastic and glass vessels, the probe can also be mounted on the outside wall under certain conditions.

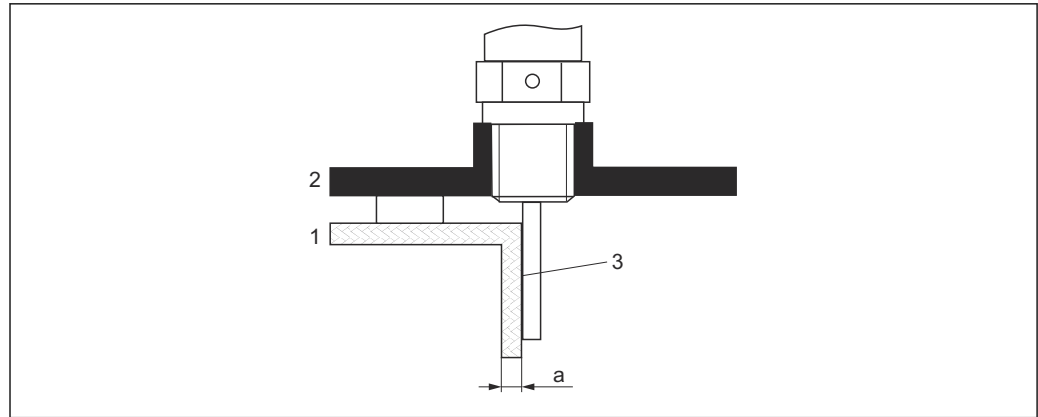

A0014150

- 1 Plastic or glass vessel
- 2 Metal plate with screw-in sleeve
- 3 No space between vessel wall and probe!

Requirements

- Relative permittivity of medium: $\epsilon_r > 7$
- Non-conductive vessel wall.
- Maximum wall thickness (a):
 - Plastic: < 15 mm (0.6 in)
 - Glass: < 10 mm (0.4 in)
- No metal reinforcements on the vessel

Note the following when mounting the device:

- Mount the probe directly on the tank wall without any clearance.
- To protect against interference with the measurement, fit a plastic half pipe with a minimum diameter of 200 mm (8 in) or a similar protective unit on the probe.
- If the vessel diameter is less than 300 mm (12 in):
 - On the opposite side of the vessel, fit a grounding plate that is conductively connected to the process connection and covers around half of the vessel's circumference.
- If the vessel diameter is 300 mm (12 in) or higher:
 - At the process connection, fit a metal plate with a diameter of at least 200 mm (8 in) at a right angle to the probe (see above).

Adjustment when mounting on the vessel exterior

When the probe is mounted on the outside of the vessel wall, the wave velocity of the signal is reduced. There are two ways to compensate for this.

Compensation via gas phase compensation factor

The effect of the dielectric wall is comparable to the effect of a dielectric gas phase and can therefore be corrected in the same way. The correction factor is calculated as the quotient of the actual probe length LN and the probe length measured when the vessel is empty.

i The device determines the position of the end-of-probe signal in the differential curve. Therefore, the value of the measured probe length depends on the mapping curve. In order to obtain a more accurate value, it is advisable to determine the measured probe length manually using the envelope curve display in FieldCare.

1. Parameter Expert → Sensor → Gas phase compensation → GPC mode
 - ↳ Select **Const. GPC factor** option.
2. Parameter Expert → Sensor → Gas phase compensation → Const. GPC factor
 - ↳ Quotient: Enter "(actual probe length)/(measured probe length)".

Compensation via the calibration parameters

If it is necessary to actually compensate for a gas phase, the gas phase compensation function is not available for the correction of external mounting. In this case, the

calibration parameters (**Empty calibration** and **Full calibration**) must be adjusted. In addition, a value that is greater than the actual probe length must be entered in the **Present probe length** parameter. In all three cases, the correction factor is the quotient of the probe length measured when the vessel is empty and the actual probe LN.

i The device searches for the end-of-probe signal in the differential curve. Therefore, the value of the measured probe length depends on the mapping curve. In order to obtain a more accurate value, it is advisable to determine the measured probe length manually using the envelope curve display in FieldCare.

1. Parameter Setup → Empty calibration
 - ↳ Increase the parameter value by the factor "(measured probe length)/(actual probe length)".
2. Parameter Setup → Full calibration
 - ↳ Increase the parameter value by the factor "(measured probe length)/(actual probe length)".
3. Parameter Setup → Advanced setup → Probe settings → Probe length correction → Confirm probe length
 - ↳ Select **Manual input** option.
4. Parameter Setup → Advanced setup → Probe settings → Probe length correction → Present probe length
 - ↳ Enter the measured probe length.

Vessel with thermal insulation

i If process temperatures are high, the device must be included in normal vessel insulation (1) in order to prevent the electronics heating up as a result of thermal radiation or convection. The insulation may not go beyond the points labeled "MAX" in the drawings.

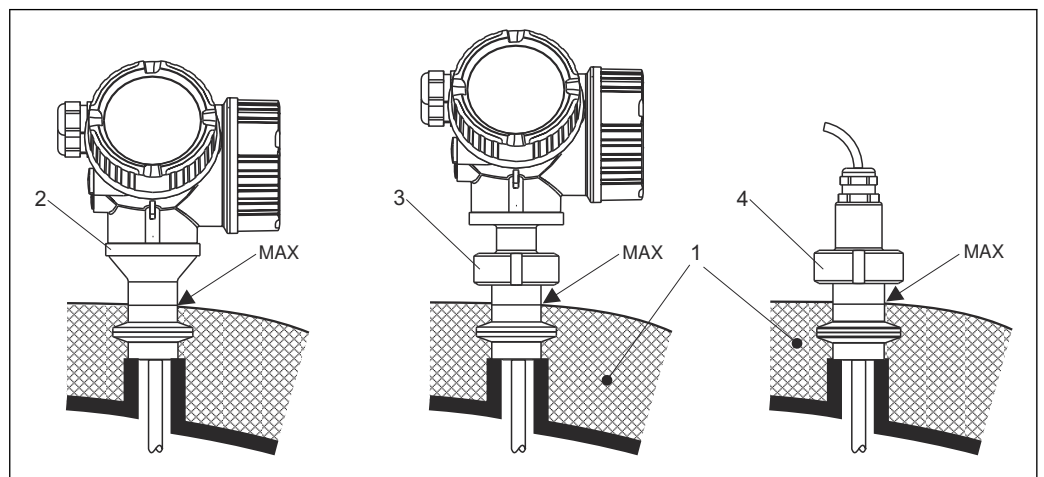

4 Hygienic process connections

- 1 Vessel insulation
- 2 Compact device
- 3 Compact device, detachable
- 4 Sensor, remote

6.2 Mounting the device

6.2.1 Tool list

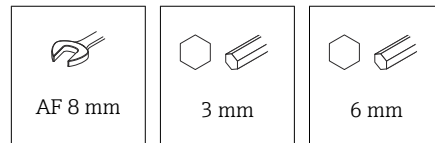

- To shorten rope probes: use a saw or bolt cutters.
- To shorten rod or coaxial probes: use a saw.
- For flanges and other process connections: use an appropriate mounting tool.

6.2.2 Mounting the "Sensor, remote" version

i This section only applies for devices with the version "Probe design" = "Sensor, remote" (feature 600, version MB or MC).

The following is included in the delivery with the version "Probe design" = "Remote":

- The probe with process connection and connecting cable (3 m (9 ft) or 6 m (18 ft))
- The electronics housing
- The mounting bracket for mounting the electronics housing on a wall or post

i The connecting cable is connected to the probe upon delivery.

i The probe with the connection cable and the electronics are mutually compatible and bear a common serial number. Only components with the same serial number may be connected to one another.

CAUTION

Mechanical stress can damage the plug of the connection cable or cause it to become loose.

- ▶ Mount the probe and the electronics housing securely before connecting the connecting cable.
- ▶ Lay the connecting cable in such a way that it is not exposed to mechanical stress.
Minimum bending radius: 50 mm (2 in).
- ▶ Torque of the union nut at the plug on the electronics side: 6 Nm
- ▶ Torque of the union nut at the plug on the sensor side: 20 Nm

i In the event of strong vibrations, a locking compound, e.g. Loctite 243, can also be used on the plug on the electronics side.

Mounting the electronics housing

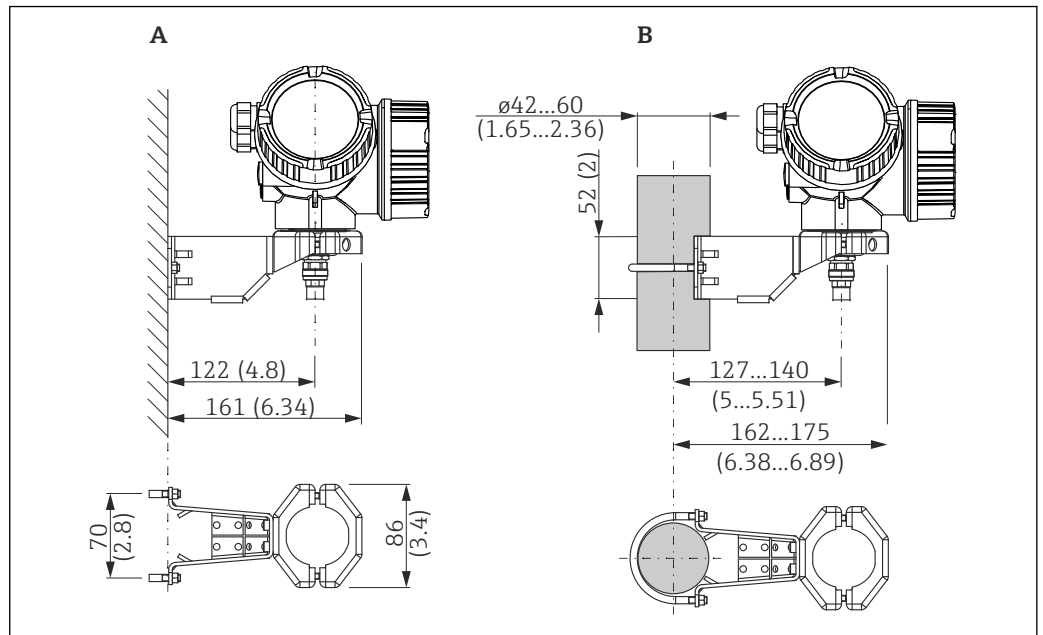

A0034793

5 Mounting the electronics housing with the mounting bracket. Unit of measurement mm (in)

A Wall mounting

B Post mounting

Connecting the connecting cable

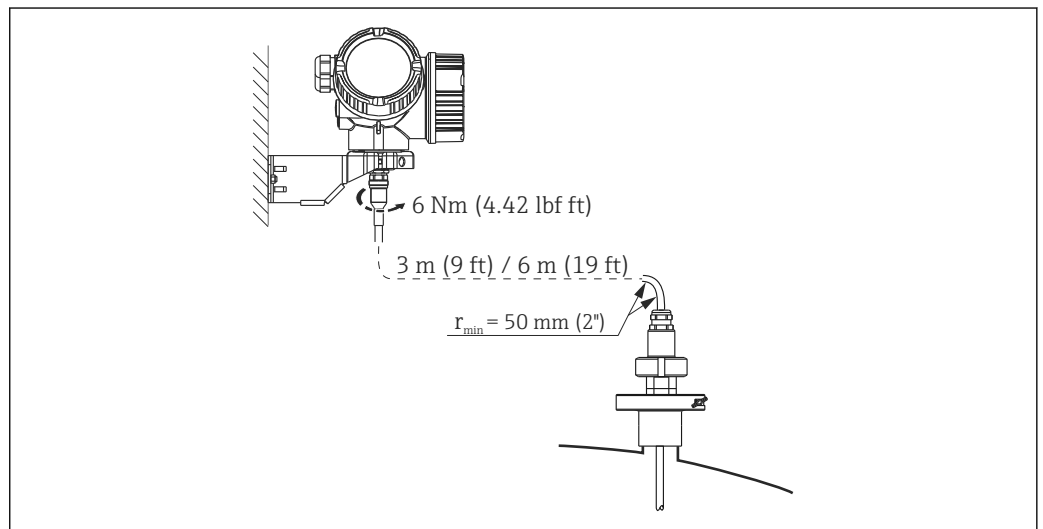
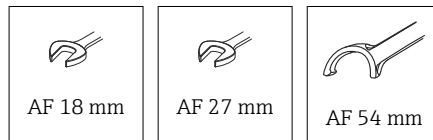

A0015103

6.2.3 Turning the transmitter housing

To provide easier access to the connection compartment or display module, the transmitter housing can be turned:

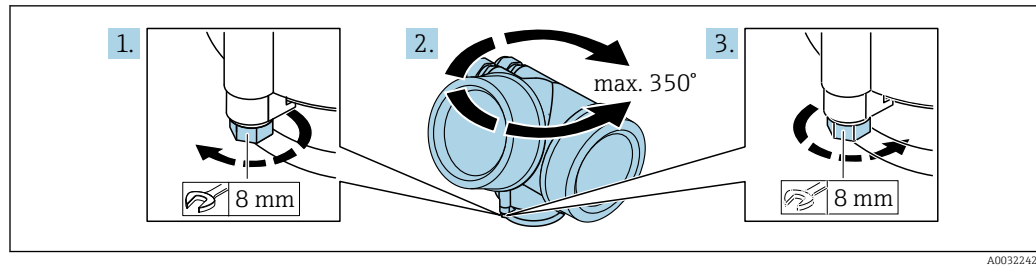

A0032242

1. Unscrew the securing screw using an open-ended wrench.
2. Rotate the housing in the desired direction.
3. Tighten the securing screw (1.5 Nm for plastic housings; 2.5 Nm for aluminum or stainless steel housing).

6.2.4 Turning the display

Opening the cover

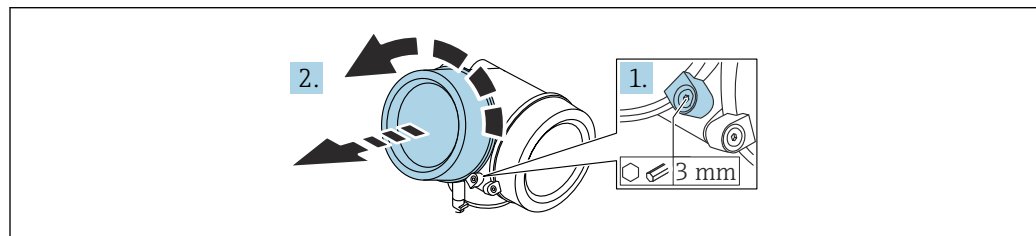

A0021430

1. Loosen the screw of the securing clamp of the electronics compartment cover using an Allen key (3 mm) and turn the clamp 90° counterclockwise.
2. Unscrew the electronics compartment cover and check the cover seal; replace it if necessary.

Turning the display module

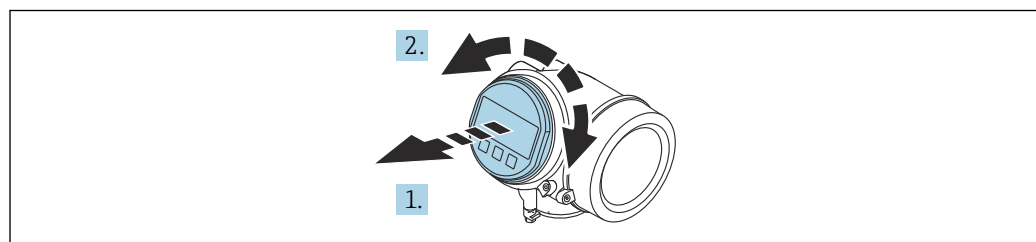

A0036401

1. Pull out the display module with a gentle rotational movement.
2. Turn the display module to the desired position: Max. $8 \times 45^\circ$ in each direction.
3. Feed the coiled cable into the gap between the housing and main electronics module and plug the display module into the electronics compartment until it engages.

Closing the cover of the electronics compartment

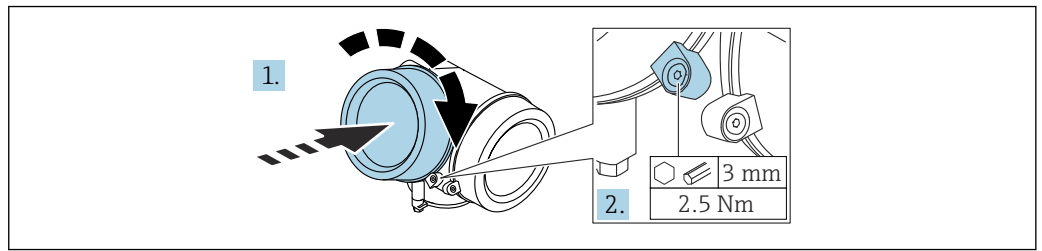

1. Screw down the cover of the electronics compartment.
2. Turn the securing clamp 90 ° in the clockwise direction and, using an Allen key (3 mm), tighten the screw of the securing clamp on the electronics compartment cover with 2.5 Nm.

6.3 Post-mounting check

- Is the device free from damage (visual inspection)?
- Are the measuring point identification and labeling correct (visual inspection)?
- Is the measuring device protected against precipitation and sunlight?
- Are the securing screws and cover lock tightened securely?
- Does the measuring device comply with the measuring point specifications?

For example:

- Process temperature
- Process pressure
- Ambient temperature
- Measuring range

7 Electrical connection

7.1 Connecting requirements

7.1.1 Terminal assignment

Terminal assignment, 2-wire: 4 to 20 mA HART

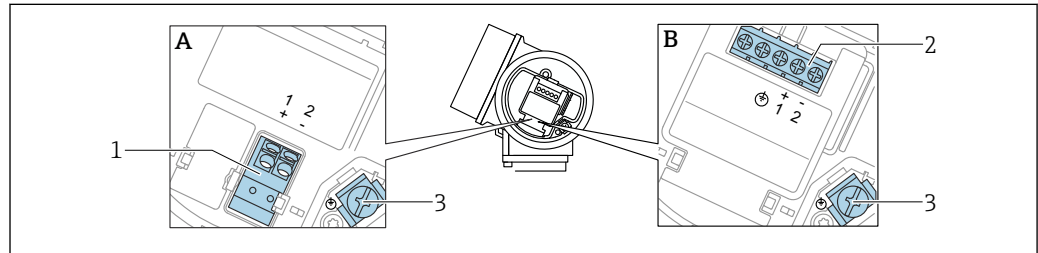

A0036498

6 Terminal assignment, 2-wire: 4 to 20 mA HART

A Without integrated overvoltage protection

B With integrated overvoltage protection

1 Connection 4 to 20 mA, HART passive: terminals 1 and 2, without integrated overvoltage protection

2 Connection 4 to 20 mA, HART passive: terminals 1 and 2, with integrated overvoltage protection

3 Terminal for cable shield

Function diagram of 4 to 20 mA HART

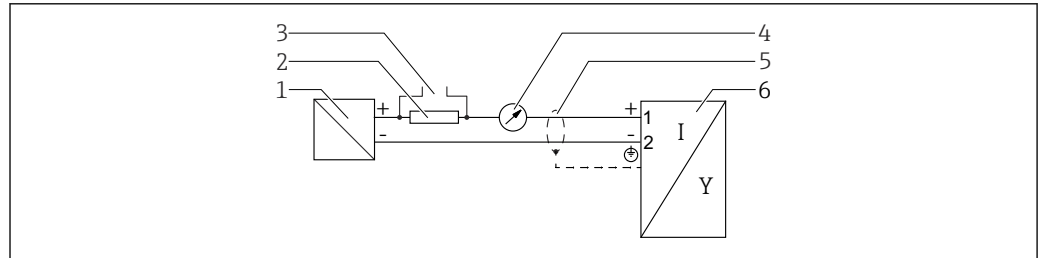

A0036499

7 Function diagram of 4 to 20 mA HART

1 Active barrier for power supply; observe terminal voltage.

2 Resistor for HART communication ($\geq 250 \Omega$); observe maximum load

3 Connection for Commubox FXA195 or FieldXpert (via VIATOR Bluetooth modem)

4 Analog display unit; observe maximum load

5 Cable screen; observe cable specification

6 Measuring instrument

Terminal assignment, 2-wire: 4 to 20 mA HART, switch output

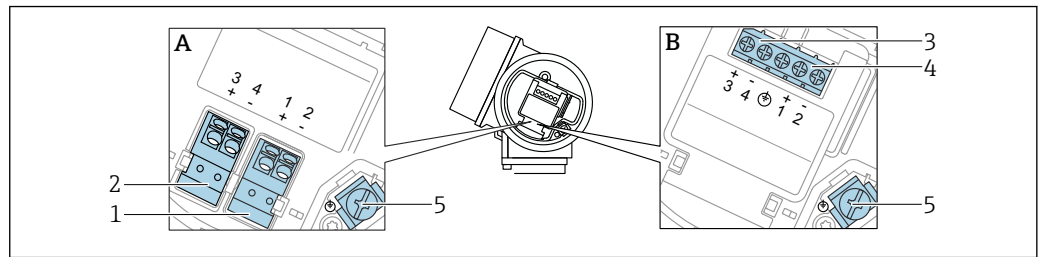

A0036500

8 Terminal assignment, 2-wire: 4 to 20 mA HART, switch output

A Without integrated overvoltage protection

B With integrated overvoltage protection

1 Connection 4 to 20 mA, HART passive: terminals 1 and 2, without integrated overvoltage protection

2 Connection, switch output (open collector): terminals 3 and 4, without integrated overvoltage protection

3 Connection, switch output (open collector): terminals 3 and 4, with integrated overvoltage protection

4 Connection 4 to 20 mA, HART passive: terminals 1 and 2, with integrated overvoltage protection

5 Terminal for cable shield

Function diagram 4 to 20 mA HART, switch output

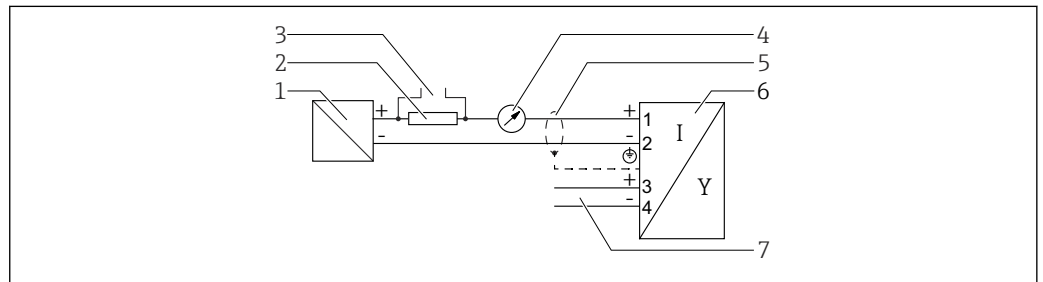

A0036501

9 Function diagram 4 to 20 mA HART, switch output

1 Active barrier for power supply; observe terminal voltage.

2 Resistor for HART communication ($\geq 250 \Omega$); observe maximum load.

3 Connection for Commubox FXA195 or FieldXpert (via VIATOR Bluetooth modem)

4 Analog display unit; observe maximum load

5 Cable screen; observe cable specification

6 Measuring instrument

7 Switch output (open collector)

Connection example of relay

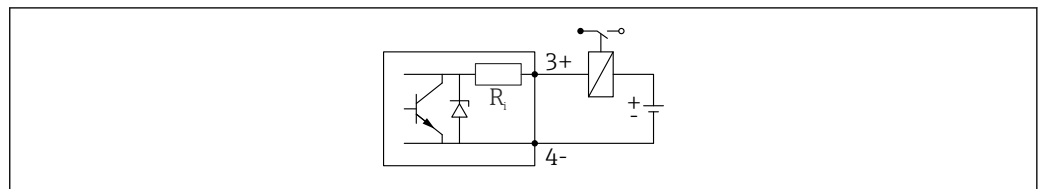

A0015909

10 Connection example of relay

Connection example for the digital input

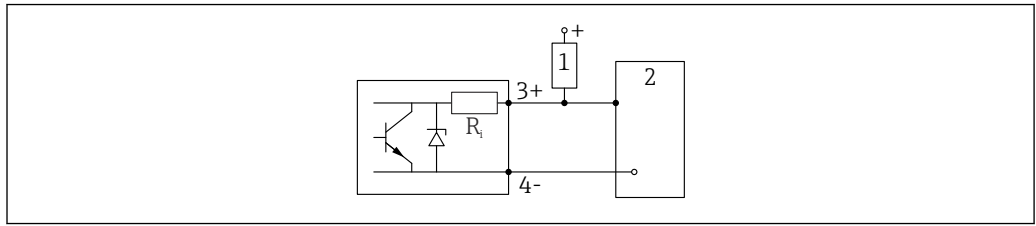

A0015910

11 Connection example for the digital input

- 1 Pull-up resistor
- 2 Digital input

Terminal assignment, 2-wire: 4 to 20 mA HART, 4 to 20 mA

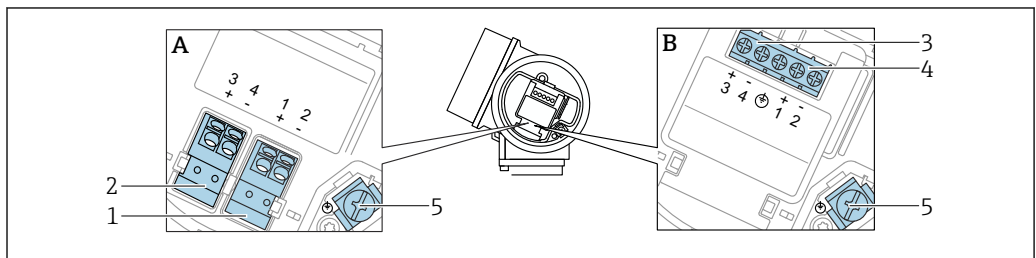

A0036500

12 Terminal assignment, 2-wire: 4 to 20 mA HART, 4 to 20 mA

- A Without integrated overvoltage protection
- B With integrated overvoltage protection
- 1 Connection current output 1, 4 to 20 mA HART passive: terminals 1 and 2, without integrated overvoltage protection
- 2 Connection current output 2, 4 to 20 mA: terminals 3 and 4, without integrated overvoltage protection
- 3 Connection current output 2, 4 to 20 mA: terminals 3 and 4, with integrated overvoltage protection
- 4 Connection current output 1, 4 to 20 mA HART passive: terminals 1 and 2, with integrated overvoltage protection
- 5 Terminal for cable shield

Function diagram 4 to 20 mA HART + 4 to 20 mA analog

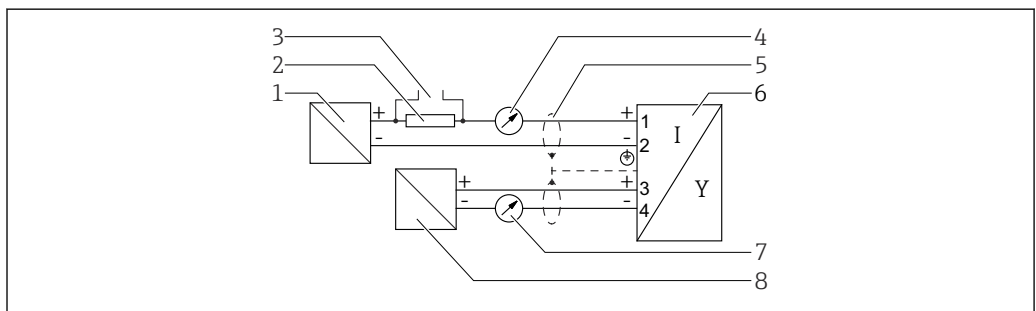

A0036502

13 Function diagram 4 to 20 mA HART + 4 to 20 mA analog

- 1 Active barrier for power supply, current output 1; observe terminal voltage.
- 2 Resistor for HART communication ($\geq 250 \Omega$); observe maximum load.
- 3 Connection for Commubox FXA195 or FieldXpert (via VIATOR Bluetooth modem)
- 4 Analog display unit; observe maximum load
- 5 Cable screen; observe cable specification
- 6 Measuring instrument
- 7 Analog display unit; observe maximum load
- 8 Active barrier for power supply, current output 2; observe terminal voltage.

Terminal assignment, 4-wire: 4 to 20 mA HART (10.4 to 48 V_{DC})

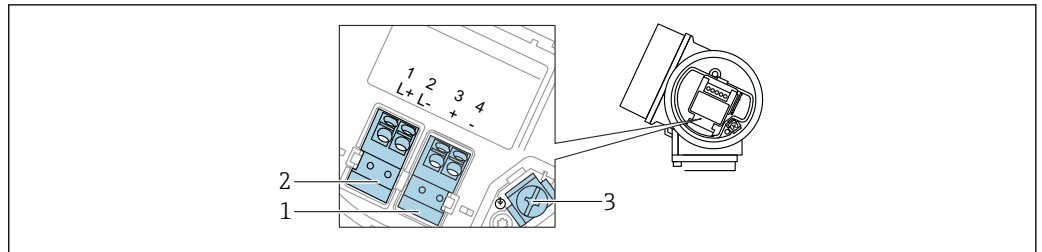

A0036516

14 Terminal assignment, 4-wire: 4 to 20 mA HART (10.4 to 48 V_{DC})

- 1 Connection 4 to 20 mA HART (active): terminals 3 and 4
- 2 Power supply connection: terminals 1 and 2
- 3 Terminal for cable shield

Function diagram 4-wire: 4 to 20 mA HART (10.4 to 48 V_{DC})

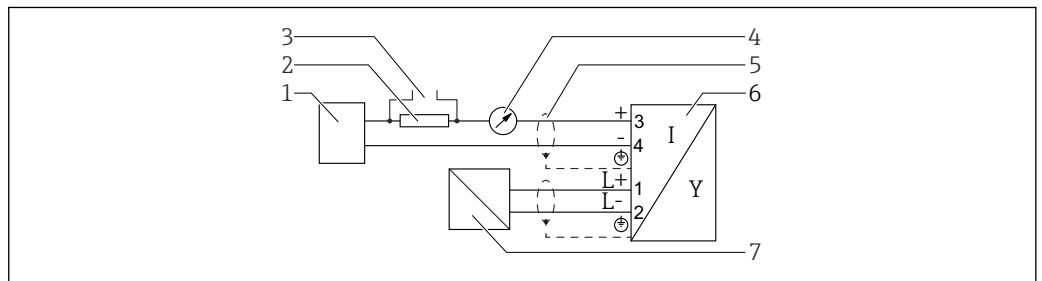

A0036526

15 Function diagram 4-wire: 4 to 20 mA HART (10.4 to 48 V_{DC})

- 1 Evaluation unit, e.g. PLC
- 2 Resistor for HART communication ($\geq 250 \Omega$); observe maximum load
- 3 Connection for Commubox FXA195 or FieldXpert (via VIATOR Bluetooth modem)
- 4 Analog display unit; observe maximum load
- 5 Cable screen; observe cable specification
- 6 Device
- 7 Supply voltage; observe terminal voltage, observe cable specification

Terminal assignment, 4-wire: 4 to 20 mA HART (90 to 253 V_{AC})

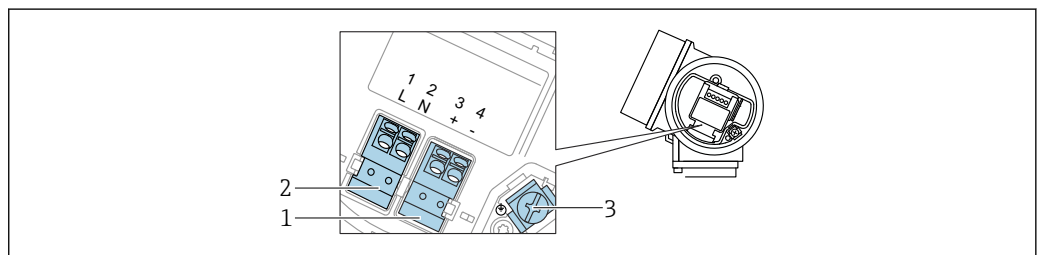

A0036519

16 Terminal assignment, 4-wire: 4 to 20 mA HART (90 to 253 V_{AC})

- 1 Connection 4 to 20 mA HART (active): terminals 3 and 4
- 2 Power supply connection: terminals 1 and 2
- 3 Terminal for cable shield

⚠ CAUTION**To ensure electrical safety:**

- ▶ Do not disconnect the protective ground connection.
 - ▶ Disconnect the device from the supply voltage before disconnecting the protective ground.
- i** Connect protective ground to the inner ground terminal (3) before connecting the power supply. If necessary, connect the potential matching line to the outer ground terminal.
 - i** In order to ensure electromagnetic compatibility (EMC): do **not** ground the device exclusively via the protective ground conductor of the supply cable. Instead, the functional grounding must also be connected to the process connection (flange or threaded connection) or to the external ground terminal.
 - i** An easily accessible power switch must be installed in the proximity of the device. The switch must be marked as a disconnecter for the device (61010IEC/).

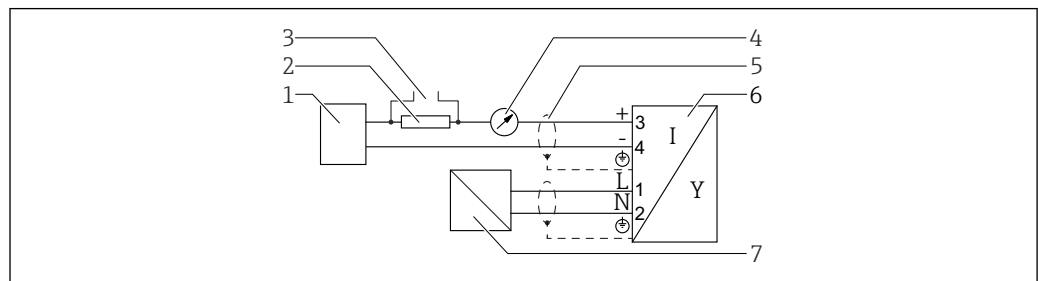
Function diagram 4-wire: 4 to 20 mA HART (90 to 253 V_{AC})

A0036527

17 Function diagram 4-wire: 4 to 20 mA HART (90 to 253 V_{AC})

- 1 Evaluation unit, e.g. PLC
- 2 Resistor for HART communication ($\geq 250 \Omega$); observe maximum load
- 3 Connection for Commubox FXA195 or FieldXpert (via VIATOR Bluetooth modem)
- 4 Analog display unit; observe maximum load
- 5 Cable screen; observe cable specification
- 6 Device
- 7 Supply voltage; observe terminal voltage, observe cable specification

7.1.2 Cable specification

- **Devices without integrated overvoltage protection**
Pluggable spring-force terminals for wire cross-sections 0.5 to 2.5 mm² (20 to 14 AWG)
- **Devices with integrated overvoltage protection**
Screw terminals for wire cross-sections 0.2 to 2.5 mm² (24 to 14 AWG)
- For ambient temperature $T_U \geq 60^\circ\text{C}$ (140 °F): use cable for temperature $T_U + 20\text{ K}$.

HART

- A normal device cable suffices if only the analog signal is used.
- A shielded cable is recommended if using the HART protocol. Observe grounding concept of the plant.
- For 4-wire devices: Standard device cable is sufficient for the power line.

7.1.3 Device plug

- i** In the case of the device versions with a plug, the housing does not need to be opened to connect the signal cable.

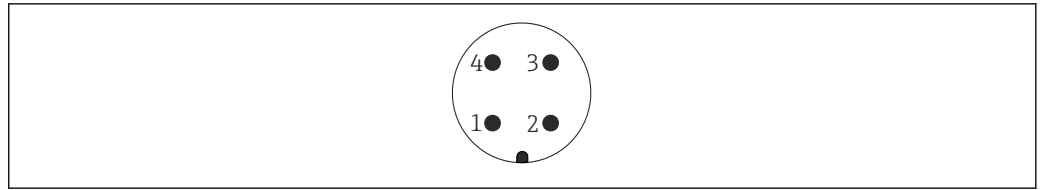

A0011175

18 Pin assignment of M12 plug

- 1 Signal +
- 2 Not assigned
- 3 Signal -
- 4 Ground

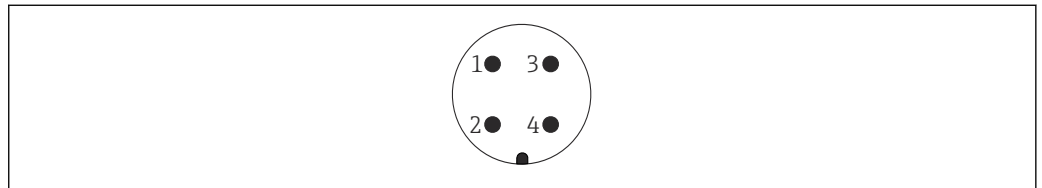

A0011176

19 Pin assignment of 7/8" plug

- 1 Signal -
- 2 Signal +
- 3 Not assigned
- 4 Shielding

7.1.4 Supply voltage

2-wire, 4-20mA HART, passive

2-wire; 4-20mA HART¹⁾

"Approval" ²⁾	Terminal voltage U at device	Maximum load R, depending on the supply voltage U ₀ of the power supply unit
<ul style="list-style-type: none"> ■ Non-hazardous ■ Ex nA ■ Ex ic ■ CSA GP 	11.5 to 35 V ^{3) 4)}	
Ex ia / IS	11.5 to 30 V ⁴⁾	
<ul style="list-style-type: none"> ■ Ex d / XP ■ Ex ic[ia] ■ Ex tD / DIP 	13.5 to 30 V ^{4) 5)}	

- 1) Feature 020 in the product structure: option A
- 2) Feature 010 in the product structure
- 3) At ambient temperatures T_a ≤ -30 °C, a terminal voltage U ≥ 14 V is required to start the device with the minimum failure current (3.6 mA). At ambient temperatures T_a > 60 °C, a terminal voltage U ≥ 12 V is required to start the device with the minimum failure current (3.6 mA). The start-up current can be configured. If the device is operated with a fixed current I ≥ 4.5 mA (HART Multidrop mode), a voltage U ≥ 11.5 V in the entire ambient temperature range suffices.
- 4) If the Bluetooth module is used, the minimum supply voltage increases by 2 V.
- 5) At ambient temperatures T_a ≤ -30 °C, a terminal voltage U ≥ 16 V is required to start the device with the minimum failure current (3.6 mA).

2-wire; 4-20 mA HART, switch output¹⁾

"Approval" ²⁾	Terminal voltage U at device	Maximum load R, depending on the supply voltage U ₀ of the power supply unit
<ul style="list-style-type: none"> ■ Non-hazardous ■ Ex nA ■ Ex nA(ia) ■ Ex ic ■ Ex ic[ia] ■ Ex d[ia] / XP ■ Ex ta / DIP ■ CSA GP 	13.5 to 35 V ^{3) 4)}	
<ul style="list-style-type: none"> ■ Ex ia / IS ■ Ex ia + Ex d[ia] / IS + XP 	13.5 to 30 V ^{3) 4)}	

- 1) Feature 020 in the product structure: option B
- 2) Feature 010 in the product structure
- 3) At ambient temperatures T_a ≤ -30 °C, a terminal voltage U ≥ 16 V is required to start the device with the minimum failure current (3.6 mA).
- 4) If the Bluetooth module is used, the minimum supply voltage increases by 2 V.

2-wire; 4-20mA HART, 4-20mA ¹⁾

"Approval" ²⁾	Terminal voltage U at device	Maximum load R, depending on the supply voltage U ₀ of the power supply unit
all	Channel 1: 13.5 to 30 V ^{3) 4) 5)}	
	Channel 2: 12 to 30 V	

- 1) Feature 020 in the product structure: option C
- 2) Feature 010 in the product structure
- 3) At ambient temperatures T_a ≤ -30 °C, a terminal voltage U ≥ 16 V is required to start the device with the minimum failure current (3.6 mA).
- 4) At ambient temperatures T_a ≤ -40 °C, the maximum terminal voltage must be limited to U ≤ 28 V.
- 5) If the Bluetooth module is used, the minimum supply voltage increases by 2 V.

Integrated polarity reversal protection	Yes
Permitted residual ripple with f = 0 to 100 Hz	U _{SS} < 1 V
Permitted residual ripple with f = 100 to 10000 Hz	U _{SS} < 10 mV

4-wire, 4-20mA HART, active

"Power supply; output" ¹⁾	Terminal voltage U	Maximum load R _{max}
K: 4-wire 90-253VAC; 4-20mA HART	90 to 253 V _{AC} (50 to 60 Hz), overvoltage category II	500 Ω
L: 4-wire 10.4-48VDC; 4-20mA HART	10.4 to 48 V _{DC}	

- 1) Feature 020 in the product structure

7.1.5 Overvoltage protection

If the device is intended to be used for level measurement of flammable liquids which requires overvoltage protection in accordance with DIN EN 60079-14, test standard 60060-1 (10 kA, pulse ⁸/₂₀ μs): use the overvoltage protection module.

Integrated overvoltage protection module

An integrated overvoltage protection module is available for the HART 2-wire devices as well as for PROFIBUS PA and FOUNDATION Fieldbus.

Product structure: Feature 610 "Accessory mounted", option NA "Overvoltage protection".

Resistance per channel	Maximum $2 \times 0.5 \Omega$
DC sparkover voltage	400 to 700 V
Trip surge voltage	< 800 V
Capacity at 1 MHz	< 1.5 pF
Nominal discharge current (8/20 μ s)	10 kA

External overvoltage protection module

The HAW562 or HAW569 for example from Endress+Hauser are suitable options for external overvoltage protection.



More information is provided in the following documents:

- HAW562: TI01012K
- HAW569: TI01013K

7.2 Connecting the device

⚠ WARNING

Explosion hazard!

- ▶ Comply with applicable national standards.
- ▶ Comply with the specifications in the Safety Instructions (XA).
- ▶ Use specified cable glands only.
- ▶ Check to ensure that the power supply matches the information on the nameplate.
- ▶ Switch off the power supply before connecting the device.
- ▶ Connect the potential matching line to the outer ground terminal before applying the power supply.

Required tools/accessories:

- For devices with a cover lock: Allen key AF3
- Wire stripper
- When using stranded cables: One ferrule for every wire to be connected.

7.2.1 Opening cover

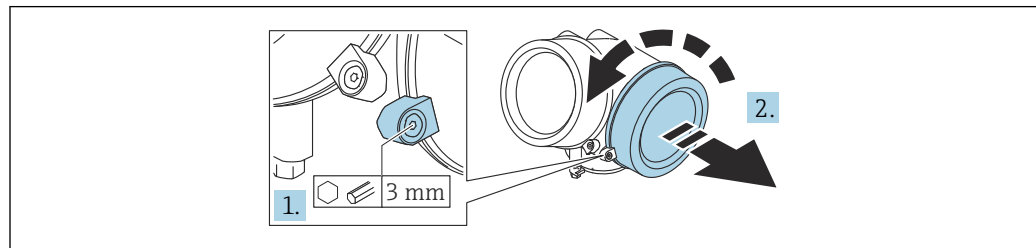

A0021490

1. Loosen the screw of the securing clamp of the connection compartment cover using an Allen key (3 mm) and turn the clamp 90 ° counterclockwise.
2. Unscrew the connection compartment cover and check the cover seal; replace it if necessary.

7.2.2 Connecting

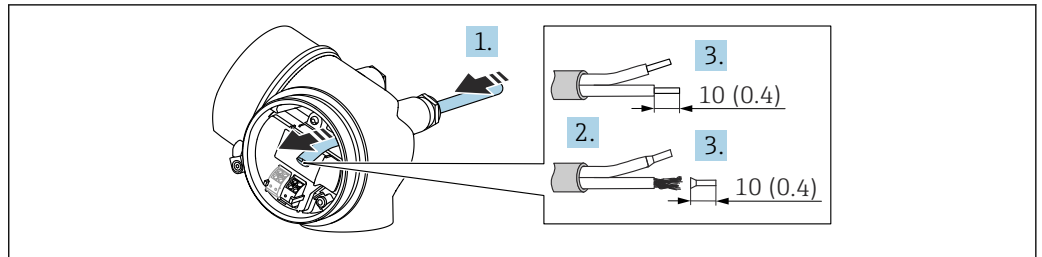

20 Unit: mm (in)

1. Push the cable through the cable entry . To ensure tight sealing, do not remove the sealing ring from the cable entry.
2. Remove the cable sheath.
3. Strip the cable ends 10 mm (0.4 in). In the case of stranded cables, also fit ferrules.
4. Firmly tighten the cable glands.
5. Connect the cable according to the terminal assignment.

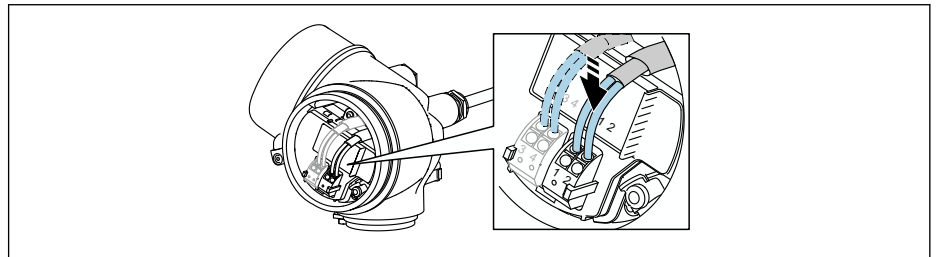

6. If using shielded cables: Connect the cable shield to the ground terminal.

7.2.3 Plug-in spring-force terminals

The electrical connection of device versions without an integrated overvoltage protection is via plug-in spring-force terminals. Rigid conductors or flexible conductors with ferrules can be inserted directly into the terminal without using the lever, and create a contact automatically.

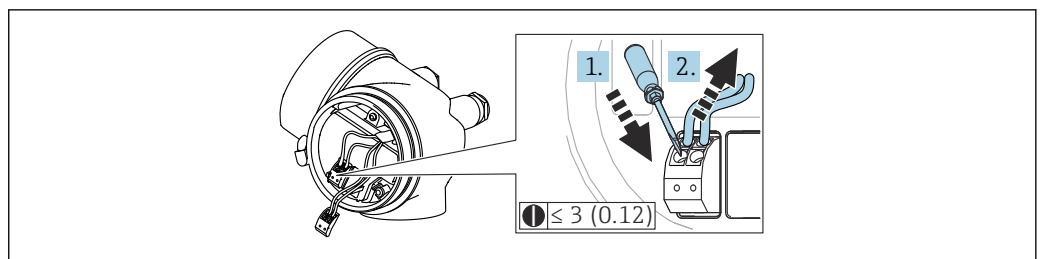

21 Unit: mm (in)

To remove the cable from the terminal again:

1. Use a flat-blade screwdriver ≤ 3 mm (0.12 in) to press down on the slot between the two terminal holes.
2. Simultaneously pull the cable end out of the terminal.

7.2.4 Closing the cover of the connection compartment

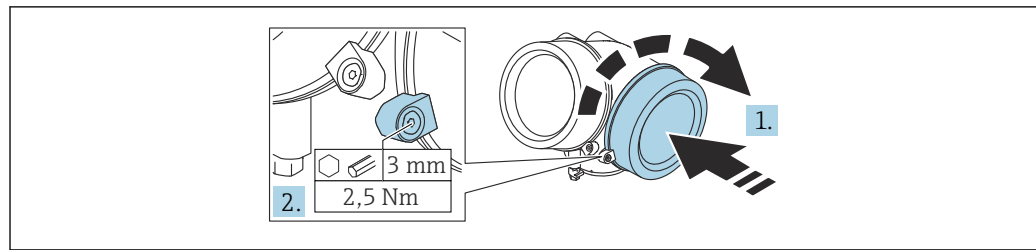

A0021491

1. Screw down the cover of the connection compartment.
2. Turn the securing clamp 90 ° in the clockwise direction and, using an Allen key (3 mm), tighten the screw of the securing clamp on the connection compartment cover with 2.5 Nm.

7.3 Post-connection check

- Is the device or cable undamaged (visual inspection)?
- Do the cables used comply with the requirements?
- Do the mounted cables have adequate strain relief?
- Are all the cable glands installed, firmly tightened and leak-tight?
- Does the supply voltage match the specifications on the nameplate?
- Is the terminal assignment correct?
- If necessary, has a protective ground connection been established?
- If supply voltage is present, is the device ready for operation and do values appear on the display module?
- Are all the housing covers installed and tightened?
- Is the securing clamp firmly tightened?

8 Operation options

8.1 Overview of operation options

8.1.1 Access to operating menu via local display

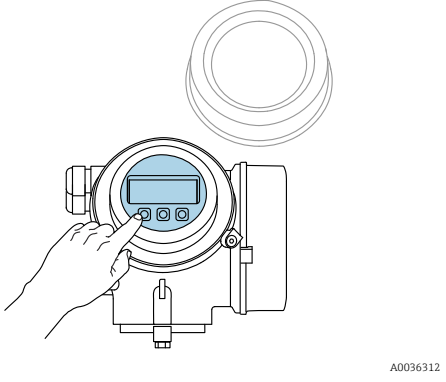
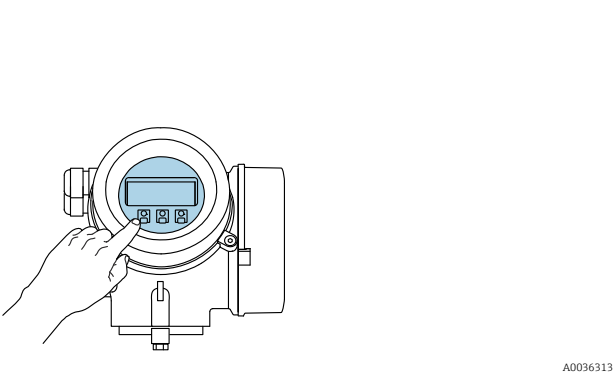
Operation with	Pushbuttons	Touch control
Order code for "Display; operation"	Option C "SD02"	Option E "SD03"
		
Display elements	4-line display	4-line display White background lighting; switches to red in event of device errors
	Format for displaying measured variables and status variables can be individually configured	
	Permitted ambient temperature for the display: -20 to +70 °C (-4 to +158 °F) The readability of the display may be impaired at temperatures outside the temperature range.	
Operating elements	Onsite operation with 3 pushbuttons (⊕, ⊖, ↻)	External operation via touch control; 3 optical keys: ⊕, ⊖, ↻
	Operating elements also accessible in various hazardous areas	
Additional functionality	Data backup function The device configuration can be saved in the display module.	
	Data comparison function The device configuration saved in the display module can be compared to the current device configuration.	
	Data transfer function The transmitter configuration can be transmitted to another device using the display module.	

Operation with remote display and operating module FHX50

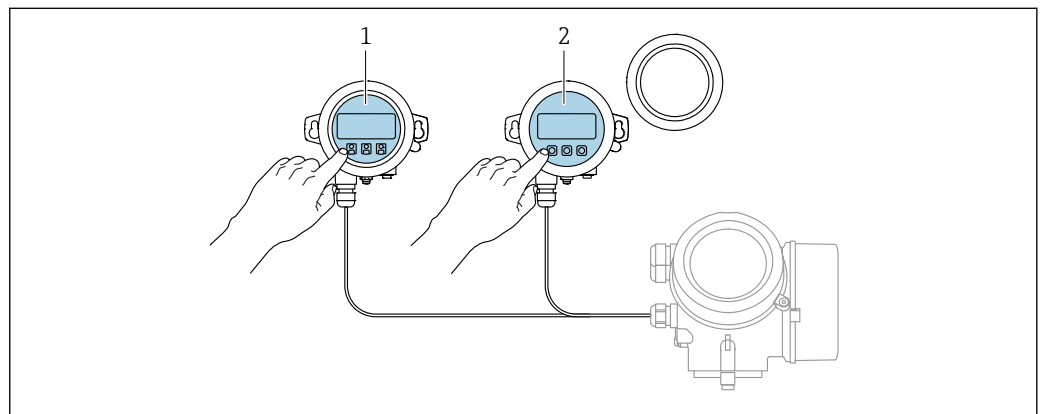

22 FHX50 operating options

- 1 Display and operating module SD03, optical keys; can be operated through the glass of the cover
- 2 Display and operating module SD02, push buttons; cover must be removed

8.1.2 Access to the operating menu via the operating tool

Via HART protocol

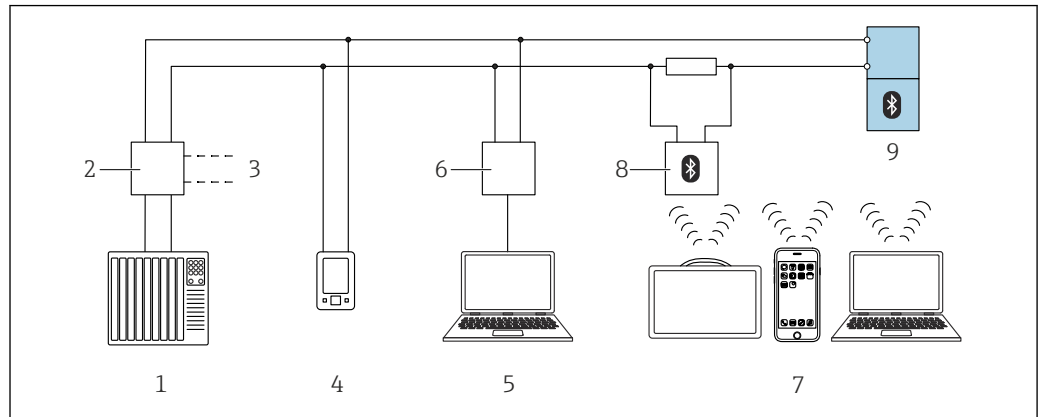

A0044334

▣ 23 Options for remote operation via HART protocol

- 1 PLC (programmable logic controller)
- 2 Transmitter power supply unit, e.g. RN221N (with communication resistor)
- 3 Connection for Commubox FXA195 and AMS Trex™ device communicator
- 4 AMS Trex™ device communicator
- 5 Computer with operating tool (e.g. DeviceCare/FieldCare , AMS Device View, SIMATIC PDM)
- 6 Commubox FXA195 (USB)
- 7 Field Xpert SMT70/SMT77, smartphone or computer with operating tool (e.g. DeviceCare/FieldCare , AMS Device View, SIMATIC PDM)
- 8 Bluetooth modem with connecting cable (e.g. VIATOR)
- 9 Transmitter

Via service interface (CDI)

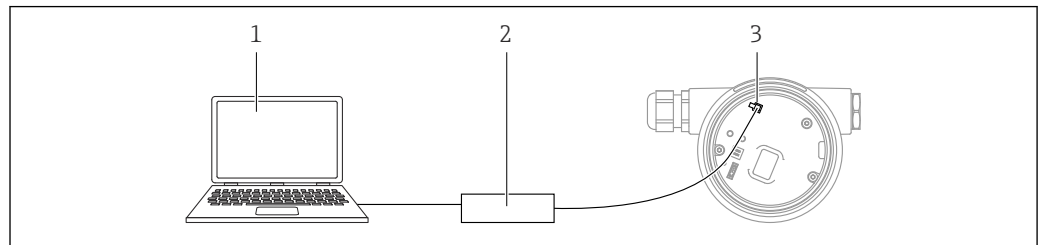

A0039148

- 1 Computer with FieldCare/DeviceCare operating tool
- 2 Commubox
- 3 Service interface (CDI) of the measuring instrument (= Endress+Hauser Common Data Interface)

Operation via Bluetooth® wireless technology

Requirements

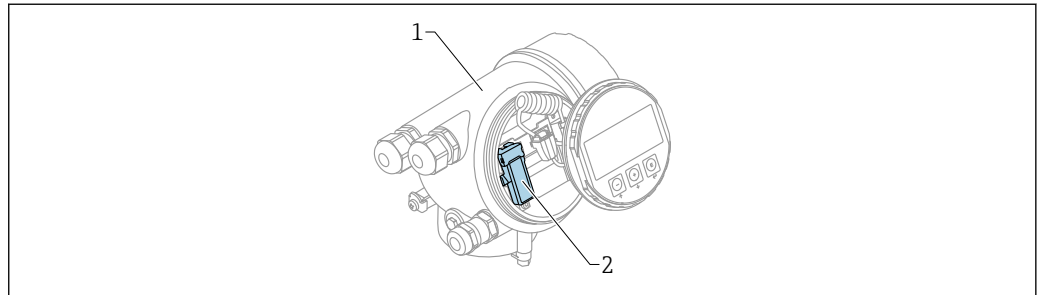

A0036790

24 Device with Bluetooth module

- 1 Electronics housing of the device
- 2 Bluetooth module

This operation option is only available for devices with Bluetooth module. There are the following options:

- The device has been ordered with a Bluetooth module:
Feature 610 "Accessory Mounted", option NF "Bluetooth"
- The Bluetooth module has been ordered as an accessory (ordering number: 71377355) and has been mounted. See Special Documentation SD02252F.

Operation via SmartBlue (app)

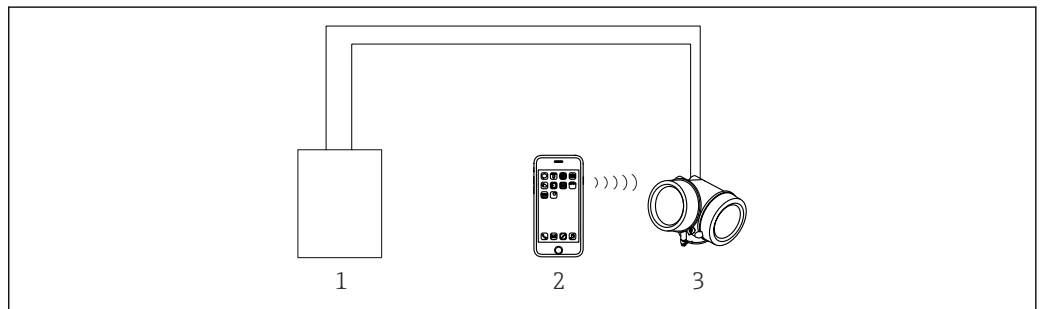

A0034939

25 Operation via SmartBlue (app)

- 1 Transmitter power supply unit
- 2 Smartphone / tablet with SmartBlue (app)
- 3 Transmitter with Bluetooth module

8.2 Structure and function of the operating menu

8.2.1 Structure of the operating menu

Menu	Submenu / parameter	Meaning
	Language ¹⁾	Defines the operating language of the local display
Commissioning ²⁾		Launches the interactive wizard for guided commissioning. Additional settings generally do not need to be made in the other menus when the wizard is finished.

Menu	Submenu / parameter	Meaning
Setup	Parameter 1 ... Parameter N	Once values have been set for these parameters, the measurement should usually be fully configured.
	Advanced setup	Contains additional submenus and parameters: <ul style="list-style-type: none"> For more accurate configuration of the measurement (adaptation to special measuring conditions). For converting the measured value (scaling, linearization). For scaling the output signal.
Diagnostics	Diagnostic list	Contains up to 5 currently active error messages.
	Event logbook ³⁾	Contains the last 20 messages (which are no longer active).
	Device information	Contains information for identifying the device.
	Measured values	Contains all current measured values.
	Data logging	Contains the history of the individual measured values
	Simulation	Is used to simulate measured values or output values.
	Device check	Contains all parameters needed to check the measurement capability of the device.
Expert ⁵⁾ Contains all the parameters of the device (including those already contained in one of the other menus). This menu is organized according to the function blocks of the device. The parameters of the Expert menu are described in: GPO1000F (HART)	System	Contains all higher-level device parameters that do not affect measurement or measured value communication.
	Sensor	Contains all parameters for configuring the measurement.
	Output	<ul style="list-style-type: none"> Contains all parameters for configuring the analog current output. Contains all parameters to configure the switch output (PFS)
	Communication	Contains all parameters needed to configure the digital communication interface.
	Diagnostics	Contains all parameters needed to detect and analyze operational errors.
	Heartbeat ⁴⁾	Contains all the wizards for the Heartbeat Verification and Heartbeat Monitoring application packages.

- 1) If you are operating via operating tools (e.g. FieldCare), the "Language" parameter is located under "Setup → Advanced setup → Display"
- 2) Only if operating via an FDT/DTM system
- 3) Only available if operating via the local display
- 4) Only available if operating via DeviceCare or FieldCare
- 5) When you call up the "Expert" menu, you are always asked for an access code. If a customer-specific access code has not been defined, "0000" must be entered.

8.2.2 User roles and related access authorization

The two user roles **Operator** and **Maintenance** have different write access to the parameters if a device-specific access code has been defined. This protects the device configuration via the local display from unauthorized access → 43.

Access authorization to parameters

User role	Read access		Write access	
	Without access code (from the factory)	With access code	Without access code (from the factory)	With access code
Operator	✓	✓	✓	--
Maintenance	✓	✓	✓	✓

If an incorrect access code is entered, the user obtains the access rights of the **Operator** role.

 The user role with which the user is currently logged on is indicated by the **Access status display** parameter (if operating via the local display) or the **Access status tooling** parameter (if operating via an operating tool).

8.2.3 Data access - Security

Write protection via access code

Using the device-specific access code, the parameters for the measuring instrument configuration are write-protected and their values can no longer be changed via local operation.

Defining the access code via the local display

1. Navigate to: Setup → Advanced setup → Administration → Define access code → Define access code
2. Define a max. 4-digit numeric code as an access code.
3. Repeat the numeric code in the **Confirm access code** parameter to confirm it.
 - ↳ The -symbol appears in front of all write-protected parameters.



Defining the access code via operating tool (e.g. FieldCare)

1. Navigate to: Setup → Advanced setup → Administration → Define access code
2. Define a max. 4-digit numeric code as an access code.
 - ↳ Write protection is active.

Parameters that can always be changed

The write protection does not include certain parameters that do not affect the measurement. Despite the defined access code, these parameters can always be modified even if the other parameters are locked.

The device automatically locks the write-protected parameters again if a key is not pressed for 10 minutes in the navigation and editing view. If the user goes from the navigation and editing mode back to the measured value display mode, the device automatically locks the write-protected parameters after 60 s.

-  If write access is activated via an access code, it can be only be deactivated again via this access code.
- In the "Description of Device Parameters" documents, each write-protected parameter is identified with the -symbol.

Disabling write protection via access code

If the  symbol appears in front of a parameter on the local display, the parameter is write-protected by a device-specific access code and its value cannot currently be changed via the local display.

The locking of the write access via local operation can be disabled by entering the device-specific access code.

1. After you press \square , the input prompt for the access code appears.
2. Enter the access code.
 - ↳ The \square symbol in front of the parameters disappears; all previously write-protected parameters are now re-enabled.

Deactivation of the write protection via access code

Via local display

1. Navigate to: Setup → Advanced setup → Administration → Define access code → Define access code
2. Enter **0000**.
3. Repeat **0000** in the **Confirm access code** parameter to confirm.
 - ↳ The write protection is deactivated. Parameters can be changed without entering an access code.

Via an operating tool (e.g. FieldCare)

1. Navigate to: Setup → Advanced setup → Administration → Define access code
2. Enter **0000**.
 - ↳ The write protection is deactivated. Parameters can be changed without entering an access code.

Write protection via write protection switch

Unlike parameter write protection via a user-specific access code, this allows the user to lock write access to the entire operating menu - apart from the **"Contrast display" parameter**.

The parameter values are now read only and cannot be edited any more (exception **"Contrast display" parameter**):

- Via local display
- Via service interface (CDI)
- Via HART protocol

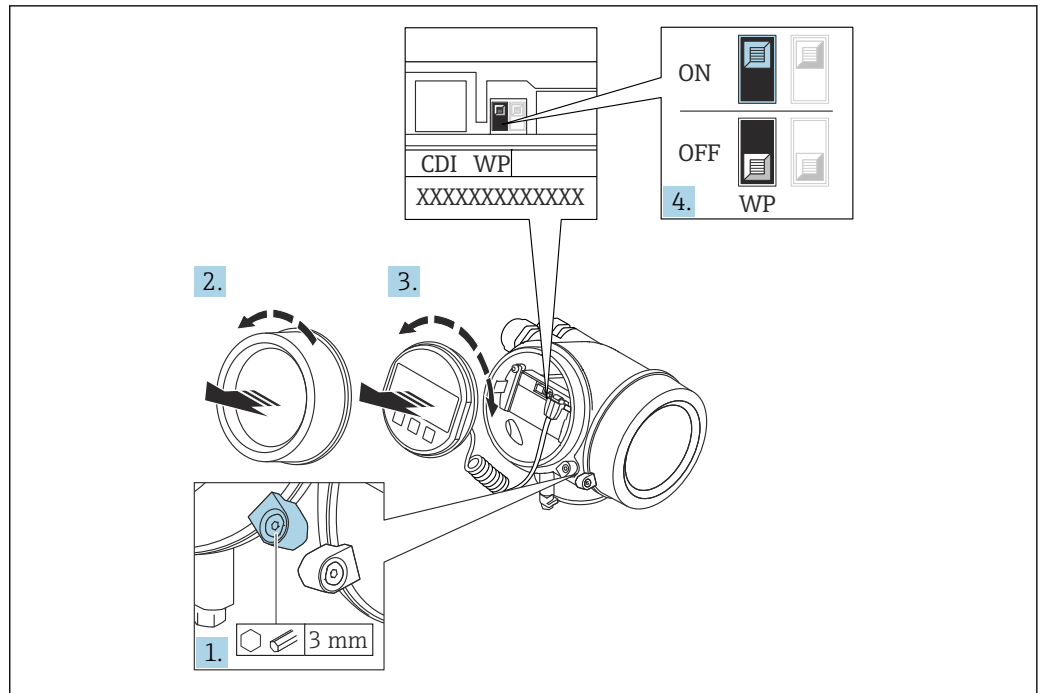

A0026157

1. Loosen the securing clamp.
2. Unscrew the electronics compartment cover.
3. Pull out the display module with a gentle rotational movement. To make it easier to access the write protection switch, attach the display module to the edge of the electronics compartment.

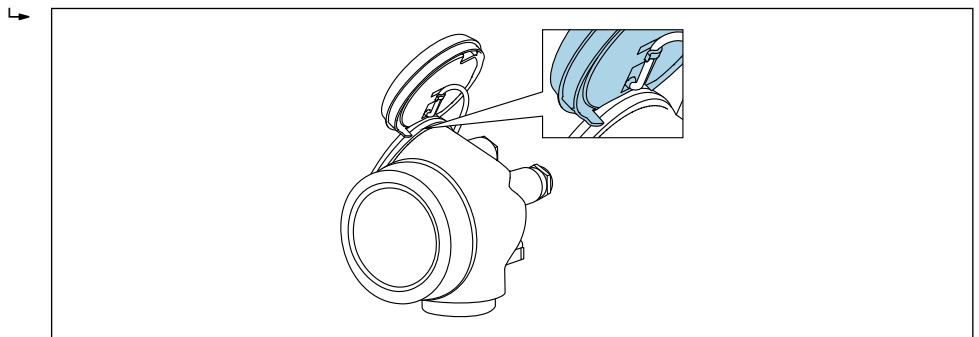

A0036086

4. Setting the write protection switch (WP) on the main electronics module to the **ON** position enables hardware write protection. Setting the write protection switch (WP) on the main electronics module to the **OFF** position (factory setting) disables hardware write protection.
 - ↳ If the hardware write protection is enabled: The **Hardware locked** option is displayed in the **Locking status** parameter. In addition, on the local display the  symbol appears in front of the parameters in the header of the operational display and in the navigation view.

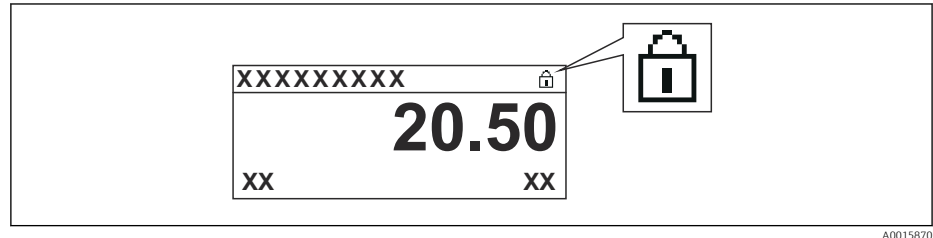

If hardware write protection is disabled: No option is displayed in the **Locking status** parameter. On the local display, the  symbol disappears from in front of the parameters in the header of the operational display and in the navigation view.

5. Feed the cable into the gap between the housing and main electronics module and plug the display module into the electronics compartment in the desired direction until it engages.
6. Reassemble the transmitter in the reverse order.

Enabling and disabling the keypad lock

Access to the entire operating menu via local operation can be locked via the keypad lock. When access is locked, it is no longer possible to navigate through the operating menu or change the values of individual parameters. Users can only read the measured values on the operational display.

The keypad lock is switched on and off via a context menu.

Switching on the keypad lock

SD03 display module only

The keypad lock is switched on automatically:

- If the device has not been operated via the display for > 1 minute.
- Each time the device is restarted.

Switching on the keypad lock manually

1. The device is in the measured value display.
Press  for at least 2 seconds.
↳ A context menu appears.
2. Select the **Keylock on** option in the context menu.
↳ The keypad lock is switched on.

 If the user attempts to access the operating menu while the keypad lock is active, the message **Keylock on** appears.

Switching off the keypad lock

1. The keypad lock is switched on.
Press  for at least 2 seconds.
↳ A context menu appears.

2. Select the **Keylock off** option in the context menu.
 - ↳ The keypad lock is switched off.

Bluetooth® wireless technology

Signal transmission via Bluetooth® wireless technology uses a cryptographic technique tested by the Fraunhofer Institute

- The device is not visible via Bluetooth® wireless technology without the SmartBlue app
- Only one point-to-point connection is established between **one** sensor and **one** smartphone or tablet

8.3 Display and operating module



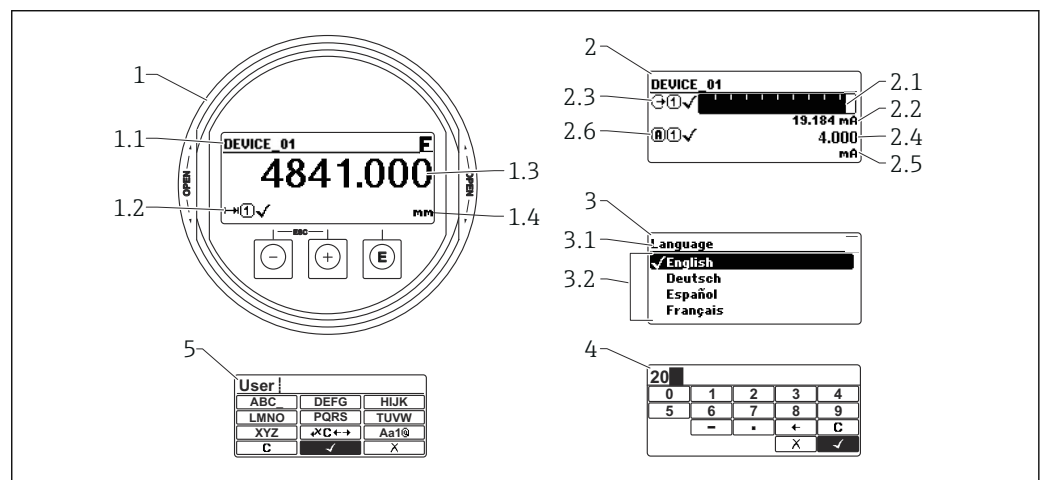

8.3.1 Display format



26 Display format on the display and operating module

- 1 Measured value display (1 value max. size)
 - 1.1 Header containing tag and error symbol (if an error is active)
 - 1.2 Measured value symbols
 - 1.3 Measured value
 - 1.4 Unit
- 2 Measured value display (bar graph + 1 value)
 - 2.1 Bargraph for measured value 1
 - 2.2 Measured value 1 (including unit)
 - 2.3 Measured value symbols for measured value 1
 - 2.4 Measured value 2
 - 2.5 Unit for measured value 2
 - 2.6 Measured value symbols for measured value 2
- 3 Parameter display (here: parameter with drop-down list)
 - 3.1 Header containing parameter name and error symbol (if an error is active)
 - 3.2 Drop-down list; marks the current parameter value.
- 4 Input matrix for numbers
- 5 Input matrix for alphanumeric and special characters



Display symbols for the submenus

Symbol	Meaning
 A0018367	Display/operat. Is displayed: <ul style="list-style-type: none"> ■ In the main menu next to the "Display/operat." selection ■ In the header on the left in the "Display/operat." menu
 A0018364	Setup Is displayed: <ul style="list-style-type: none"> ■ In the main menu next to the "Setup" selection ■ In the header on the left in the "Setup" menu
 A0018365	Expert Is displayed: <ul style="list-style-type: none"> ■ In the main menu next to the "Expert" selection ■ In the header on the left in the "Expert" menu
 A0018366	Diagnostics Is displayed: <ul style="list-style-type: none"> ■ In the main menu next to the "Diagnostics" selection ■ In the header on the left in the "Diagnostics" menu











Status signals

Symbol	Meaning
F A0032902	"Failure" A device error has occurred. The measured value is no longer valid.
C A0032903	"Function check" The device is in the service mode (e.g. during a simulation).
S A0032904	"Out of specification" The device is operated: <ul style="list-style-type: none"> ■ Outside its technical specifications (e.g. during startup or cleaning) ■ Outside the configuration performed by the user (e.g. level outside the configured range)
M A0032905	"Maintenance required" Maintenance is required. The measured value is still valid.



Display symbols for locking status





Symbol	Meaning
 A0013148	Read-only parameter The parameter shown is only for display purposes and cannot be edited.
 A0013150	Device locked <ul style="list-style-type: none"> ■ In front of a parameter name: The device is locked via software and/or hardware. ■ In the header of the measured value screen: The device is locked via hardware.

Measured value symbols

Symbol	Meaning
Measured values	
 <small>A0032892</small>	Level
 <small>A0032893</small>	Distance
 <small>A0032908</small>	Current output
 <small>A0032894</small>	Measured current
 <small>A0032895</small>	Terminal voltage
 <small>A0032896</small>	Electronics or sensor temperature
Measuring channels	
 <small>A0032897</small>	Measuring channel 1
 <small>A0032898</small>	Measuring channel 2
Status of the measured value	
 <small>A0018361</small>	"Alarm" status Measurement is interrupted. The output assumes the defined alarm condition. A diagnostic message is generated.
 <small>A0018360</small>	"Warning" status The device continues to measure. A diagnostic message is generated.

8.3.2 Operating elements

Operating key	Meaning
 <small>A0018330</small>	Minus key <i>In a menu, submenu</i> Moves the selection bar upwards in a picklist. <i>In the text and numeric editor</i> In the input screen, moves the selection bar to the left (backwards).
 <small>A0018329</small>	Plus key <i>In a menu, submenu</i> Moves the selection bar downwards in a picklist. <i>In the text and numeric editor</i> In the input screen, moves the selection bar to the right (forwards).

Operating key	Meaning
 <small>A0018328</small>	<p>Enter key</p> <p><i>For measured value display</i></p> <ul style="list-style-type: none"> Pressing the key briefly opens the operating menu. Pressing the key for 2 s opens the context menu. <p><i>In a menu, submenu</i></p> <ul style="list-style-type: none"> Pressing the key briefly: Opens the selected menu, submenu or parameter. Pressing the key for 2 s for parameter: If present, opens the help text for the function of the parameter. <p><i>In the text and numeric editor</i></p> <ul style="list-style-type: none"> Pressing the key briefly: <ul style="list-style-type: none"> Opens the selected group. Carries out the selected action. Pressing the key for 2 s confirms the edited parameter value.
 <small>A0032909</small>	<p>Escape key combination (press keys simultaneously)</p> <p><i>In a menu, submenu</i></p> <ul style="list-style-type: none"> Pressing the key briefly: <ul style="list-style-type: none"> Exits the current menu level and takes you to the next higher level. If help text is open, closes the help text of the parameter. Pressing the key for 2 s returns you to the measured value display ("home position"). <p><i>In the text and numeric editor</i></p> <p>Closes the text or numeric editor without applying changes.</p>
 <small>A0032910</small>	<p>Minus/Enter key combination (press and hold down the keys simultaneously)</p> <p>Reduces the contrast (brighter setting).</p>
 <small>A0032911</small>	<p>Plus/Enter key combination (press and hold down the keys simultaneously)</p> <p>Increases the contrast (darker setting).</p>



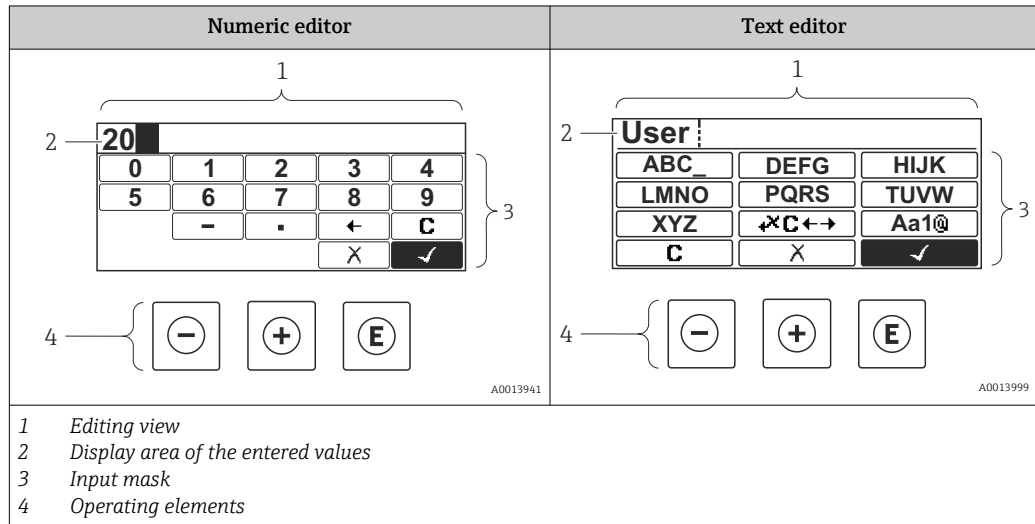



8.3.3 Entering numbers and text









Input mask

The following input and operating symbols are available in the input mask of the numeric and text editor:



Numeric editor



Symbol	Meaning
 <p>A0013998</p>	Selection of numbers from 0 to 9
 <p>A0016619</p>	Inserts decimal separator at the cursor position.
 <p>A0016620</p>	Inserts minus sign at the cursor position.
 <p>A0013985</p>	Confirms selection.
 <p>A0016621</p>	Moves the input position one position to the left.
 <p>A0013986</p>	Exits the input without applying the changes.
 <p>A0014040</p>	Clears all entered characters.

Text editor

Symbol	Meaning
 <p>A0013997</p>	Selection of letters from A to Z
 <p>A0013981</p>	Toggle <ul style="list-style-type: none"> ▪ Between upper-case and lower-case letters ▪ For entering numbers ▪ For entering special characters
 <p>A0013985</p>	Confirms selection.
 <p>A0013987</p>	Switches to the selection of the correction tools.
 <p>A0013986</p>	Exits the input without applying the changes.
 <p>A0014040</p>	Clears all entered characters.

Text correction under 

Symbol	Meaning
 <p>A0032907</p>	Clears all entered characters.
 <p>A0018324</p>	Moves the input position one position to the right.

 <small>A0018326</small>	Moves the input position one position to the left.
 <small>A0032906</small>	Deletes one character immediately to the left of the input position.

8.3.4 Opening the context menu

Using the context menu, the user can call up the following menus quickly and directly from the operational display:

- Setup
- Conf. backup disp.
- Envelope curve
- Keylock on



Calling up and closing the context menu

The user is in the operational display.

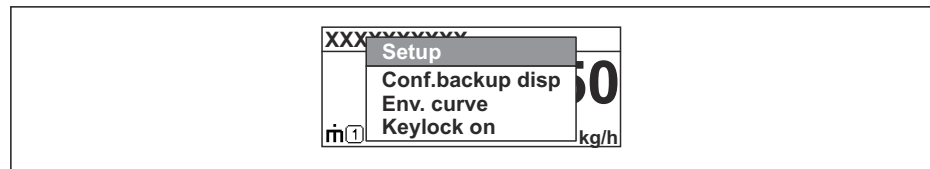

1. Press  for 2 s.
 - ↳ The context menu opens.



A0037872

2. Press  +  simultaneously.
 - ↳ The context menu is closed and the operational display appears.

Calling up the menu via the context menu

1. Open the context menu.
2. Press  to navigate to the desired menu.
3. Press  to confirm the selection.
 - ↳ The selected menu opens.

8.3.5 Envelope curve display on the display and operating module

In order to assess the measuring signal, the envelope curve and - if a mapping has been recorded - the mapping curve can be shown on the display and operating module:

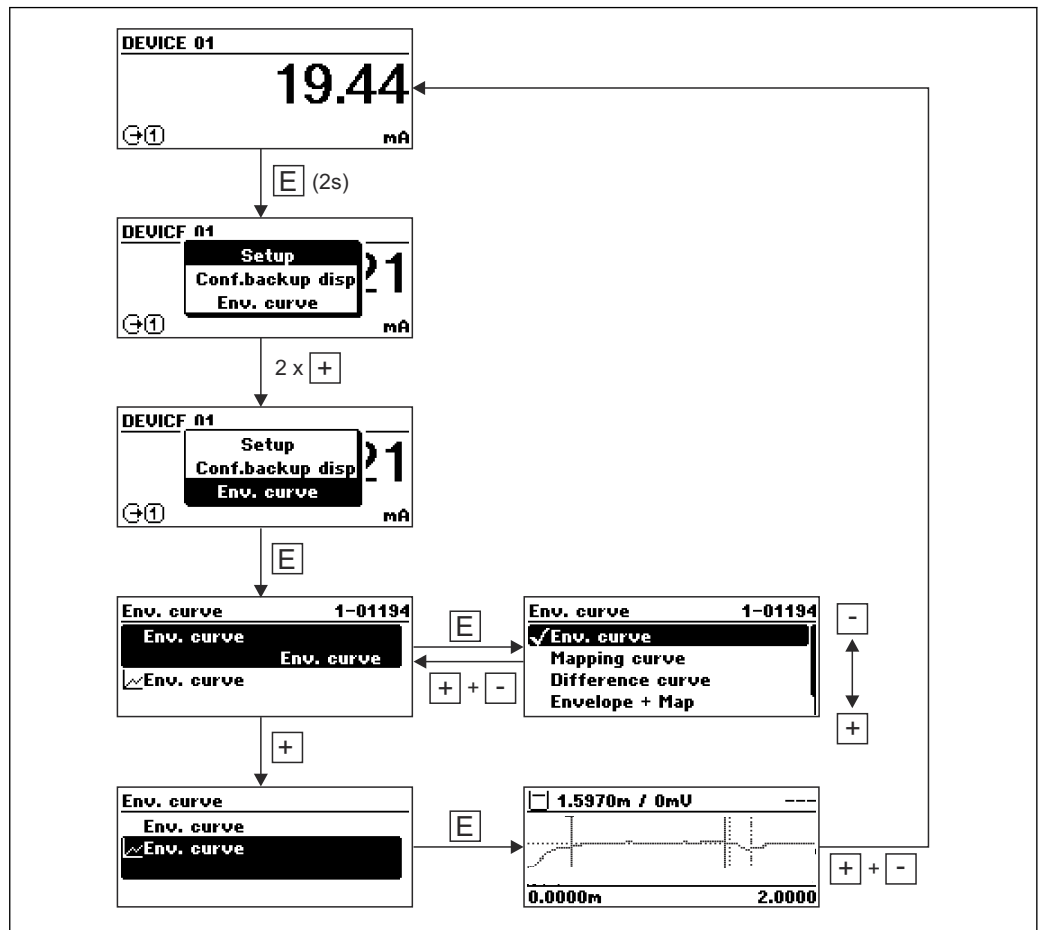

A0014277

9 System integration

9.1 Overview of the device description files

HART

Manufacturer ID	0x11
Device type code	0x1122
HART specification	7.0
DD files	Information and files available at: <ul style="list-style-type: none"> ▪ www.endress.com ▪ www.fieldcommgroup.org

9.2 Measured variables via HART protocol

The following measured values are assigned to the device variables at the factory:

Device variables for level measurement

Device variable	Measured value
Primary variable (PV)	Level linearized
Secondary variable (SV)	Unfiltered distance
Tertiary variable (TV)	Absolute echo amplitude
Quaternary variable (QV)	Relative echo amplitude

 The assignment of the measured values to the device variables can be changed in the following submenu:

Expert → Communication → Output

10 Commissioning via SmartBlue (App)

10.1 Operation via Bluetooth® wireless technology (optional)

Prerequisite

- Device with device display including Bluetooth
- Smartphone or tablet with Endress+Hauser SmartBlue app or PC with DeviceCare from version 1.07.05 or FieldXpert SMT70

The connection has a range of up to 25 m (82 ft). The range can vary depending on environmental conditions such as attachments, walls or ceilings.

 The operating keys on the display are locked as soon as the device is connected via Bluetooth.

A flashing Bluetooth symbol indicates that a Bluetooth connection is available.

 **Please note the following**

If the Bluetooth display is removed from one device and installed in another device:

- All the log-in data are only saved in the Bluetooth display and not in the device
- The password changed by the user is also saved in the Bluetooth display

10.1.1 Operation via SmartBlue App

The device can be operated and configured with the SmartBlue App.

- The SmartBlue App must be downloaded onto a mobile device for this purpose.
- For information on the compatibility of the SmartBlue App with mobile devices, see **Apple App Store (iOS devices)** or **Google Play Store (Android devices)**.
- Incorrect operation by unauthorized persons is prevented by means of encrypted communication and password encryption.
- The Bluetooth® function can be deactivated after initial device setup.

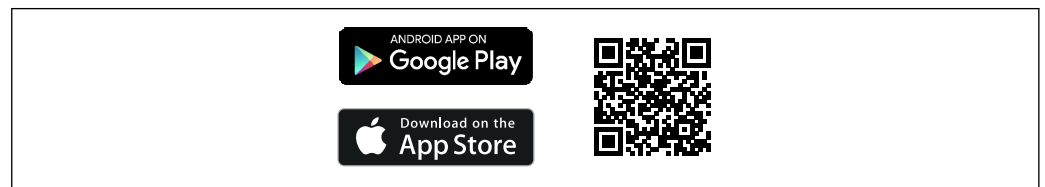

 27 QR code for free Endress+Hauser SmartBlue App

A0033202

Download and installation:

1. Scan the QR code or enter **SmartBlue** in the search field of the Apple App Store (iOS) or Google Play Store (Android).
2. Install and start the SmartBlue App.
3. For Android devices: enable location tracking (GPS) (not required for iOS devices).
4. Select a device that is ready to receive from the device list displayed.

Login:

1. Enter the user name: admin
2. Enter the initial password: serial number of the device

 Change the password after logging in for the first time.

 Forgotten your password? Contact Endress+Hauser Service.

10.2 Envelope curve display in SmartBlue

Envelope curves can be displayed and recorded in SmartBlue.

In addition to the envelope curve, the following values are displayed:

- D = Distance
- L = Level
- A = Absolute amplitude
- With screenshots, the displayed section (zoom function) is saved
- With video sequences, the whole area without zoom function is saved all the time



28 Envelope curve display (sample) in SmartBlue for Android

- 1 Record video
- 2 Create screenshot
- 3 Display mapping menu
- 4 Start/stop video recording
- 5 Move time on time axis

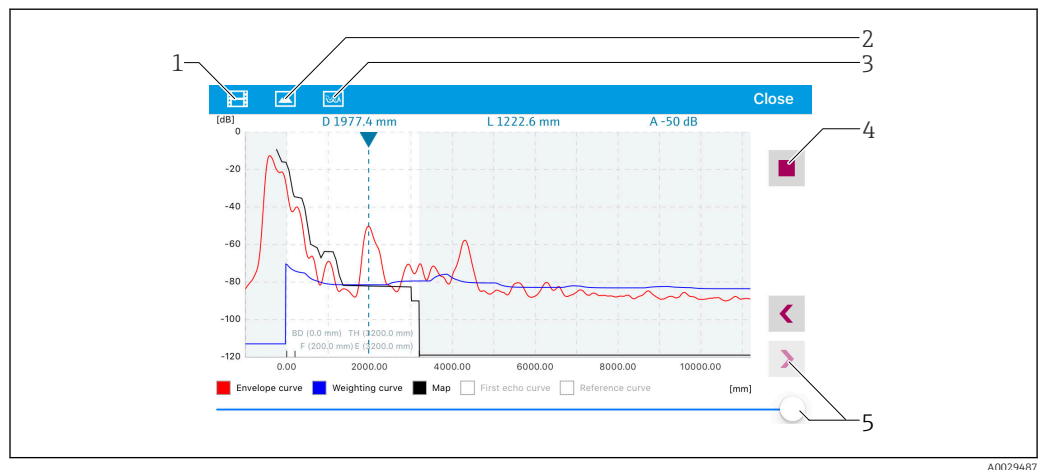

29 Envelope curve display (sample) in SmartBlue for iOS

- 1 Record video
- 2 Create screenshot
- 3 Display mapping menu
- 4 Start/stop video recording
- 5 Move time on time axis

11 Commissioning using the wizard

FieldCare and DeviceCare have a wizard that guides the user through initial commissioning.

1. Connect the device with FieldCare or DeviceCare.
2. Open the device in FieldCare or DeviceCare.
 - ↳ The dashboard (homepage) of the device is displayed:

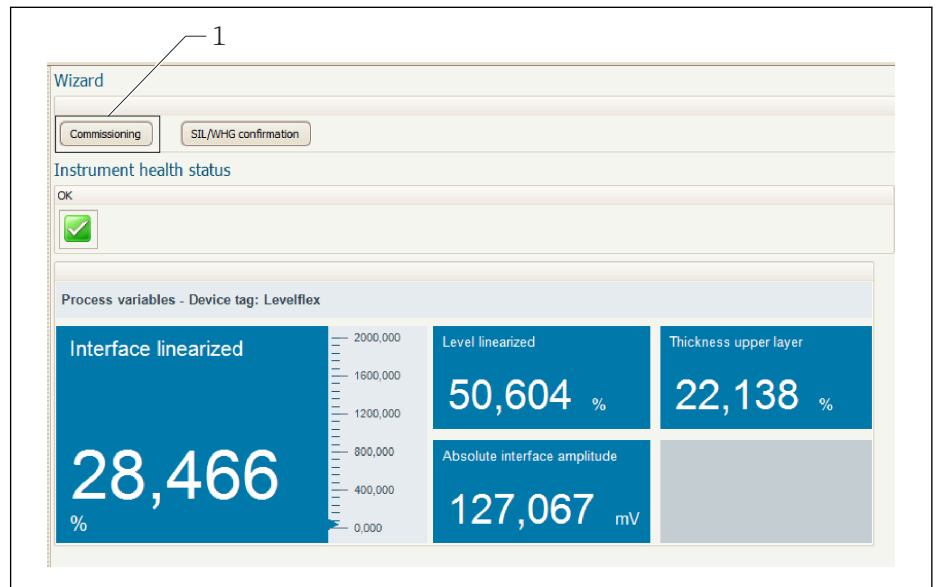

1 "Commissioning" button calls up the wizard

3. Click "Commissioning" to launch the Wizard.
 4. Enter the appropriate value in each parameter or select the appropriate option. These values are written directly to the device.
 5. Click "Next" to go to the next page.
 6. Once all the pages have been completed, click "Finish" to close the Wizard.
- i** If you cancel the Wizard before all the necessary parameters have been entered, the device may be in an undefined state. In such situations, it is advisable to reset the device to the factory default settings.

12 Commissioning via operating menu

12.1 Installation and function check

Before commissioning the measuring point, check whether the post-installation and post-connection checks have been performed.

 Post-mounting check

 Post-connection check

12.2 Configuring the operating language

Factory setting: English or ordered local language

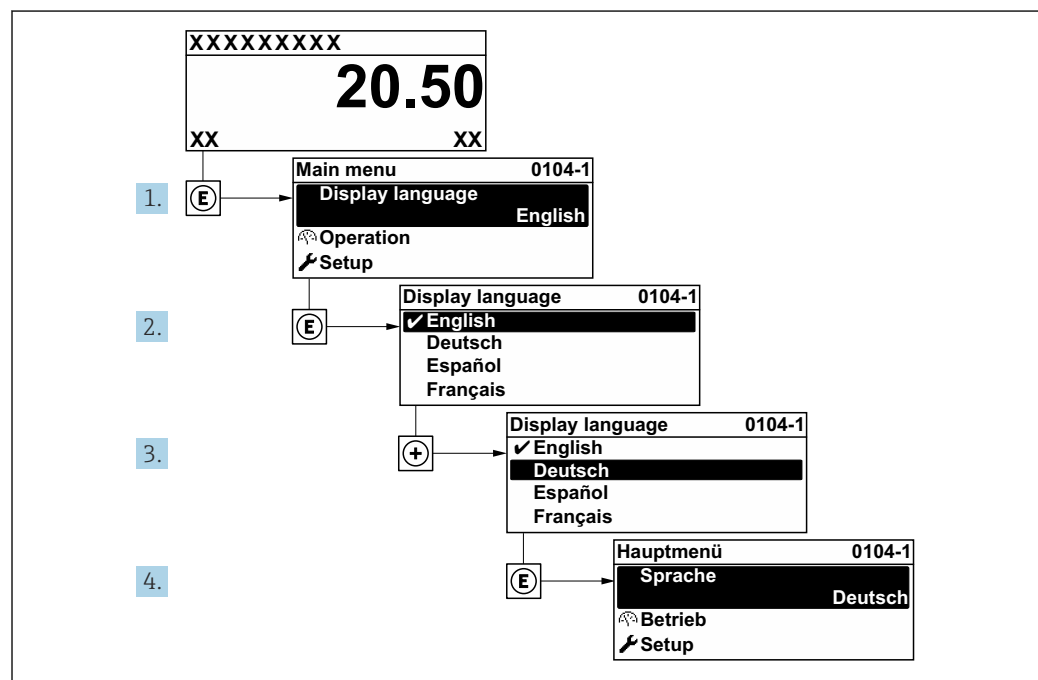

A0029420

 30 Using the example of the local display

12.3 Configuring level measurement

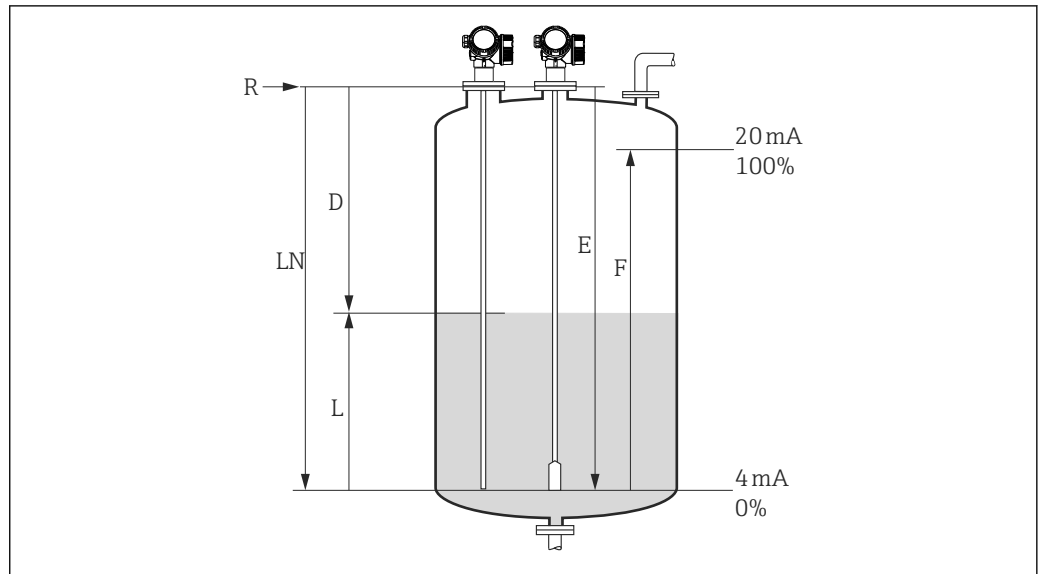

A0011360

31 Configuration parameters for level measurement in liquids

- LN Length of probe
- R Reference point of the measurement
- D Distance
- L Level
- E Empty calibration (= zero point)
- F Full calibration (= span)

i If the ϵ_r value is lower than 7 in the case of rope probes, measurement is not possible in the area of the probe weight. The empty calibration E should not exceed $LN - 250$ mm ($LN - 10$ in) in these cases.

1. Setup → Device tag
 - ↳ Enter the tag name.
2. Navigate to: Setup → Distance unit
 - ↳ Select the length unit.
3. Navigate to: Setup → Tank type
 - ↳ Select tank type.
4. For **Tank type** parameter = Bypass / pipe:
 - Navigate to: Setup → Tube diameter
 - ↳ Specify the diameter of the bypass or stilling well.
5. Navigate to: Setup → Medium group
 - ↳ Specify the medium group: (**Water based (DC >= 4)** or **Others**)
6. Navigate to: Setup → Empty calibration
 - ↳ Specify empty distance E (distance from reference point R to 0% mark).
7. Navigate to: Setup → Full calibration
 - ↳ Specify the full distance F (distance from the 0% mark to the 100% mark).
8. Navigate to: Setup → Level
 - ↳ Displays the measured level L .
9. Navigate to: Setup → Distance
 - ↳ Displays the distance D between the reference point R and the level L .
10. Navigate to: Setup → Signal quality
 - ↳ Displays the signal quality of the analyzed level echo.

11. Operation via local display:
Navigate to: Setup → Mapping → Confirm distance
↳ Compare the distance displayed with the actual value to start recording an interference echo map if necessary.
12. Operation via operating tool:
Navigate to: Setup → Confirm distance
↳ Compare the distance displayed with the actual value to start recording an interference echo map if necessary.

12.4 Recording the reference echo curve

After the measurement has been configured, it is recommended to record the current envelope curve as a reference echo curve. This can then be used later for diagnostic purposes. The **Save reference curve** parameter is used to record the envelope curve.

Path in the menu

Expert → Diagnostics → Envelope diagnostics → Save reference curve

Meaning of the options

- No
No action
- Yes
The current envelope curve is saved as a reference curve.

 This submenu is only visible for the "Service" user role in devices supplied with software version 01.00.zz or 01.01.zz.

 The reference echo curve can only be displayed in the envelope curve diagram of FieldCare after it has been loaded from the device into FieldCare. The "Load Reference Curve" function in FieldCare is used for this.

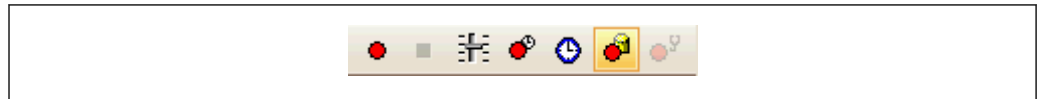

 32 "Load Reference Curve" function

12.5 Configuring the local display

12.5.1 Factory setting of local display for level measurements

Parameter	Factory setting for devices with 1 current output	Factory setting for devices with 2 current outputs
Format display	1 value, max. size	1 value, max. size
Value 1 display	Level linearized	Level linearized
Value 2 display	Distance	Distance
Value 3 display	Current output 1	Current output 1
Value 4 display	None	Current output 2

12.5.2 Adjusting the local display

The local display can be adjusted in the following submenu:
Setup → Advanced setup → Display

12.6 Configuring the current outputs

12.6.1 Factor setting of current outputs for level measurements

Current output	Assigned measured value	4mA value	20mA value
1	Level linearized	0% or the corresponding linearized value	100% or the corresponding linearized value
2 (For devices with two current outputs)	Relative echo amplitude	0 mV	2 000 mV

12.6.2 Adjusting the current outputs

The current outputs can be adjusted in the following submenus:

Basic setup

Setup → Advanced setup → Current output 1 to 2

Advanced settings

Expert → Output 1 to 2 → Current output 1 to 2

See "Description of Device Parameters" GP01000F

12.7 Configuration management

After commissioning, you can save the current device configuration, copy it to another measuring point or restore the previous device configuration. You can do so using the **Configuration management** parameter and the options available.

Path in the menu

Setup → Advanced setup → Configuration backup display → Configuration management

Meaning of the options

■ Cancel

No action is executed and the user exits the parameter.

■ Execute backup

A backup copy of the current device configuration is saved from the HistoROM (integrated in the device) to the display module of the device.

■ Restore

The last backup copy of the device configuration is copied from the display module to the HistoROM of the device.

- **Duplicate**

The transmitter configuration of the device is duplicated to another device using the display module. The following parameters, which characterize the individual measuring point are **not** transferred:

- HART date code
- HART short tag
- HART message
- HART descriptor
- HART address
- Device tag
- Medium type

- **Compare**

The device configuration saved in the display module is compared to the current device configuration of the HistoROM. The result of the comparison is displayed in the **Comparison result** parameter.

- **Clear backup data**

The backup copy of the device configuration is deleted from the display module of the device.

 While this action is in progress, the configuration cannot be edited via the local display and a message on the processing status appears on the display.

 If an existing backup copy is restored on a device other than the original device using the **Restore** option, in some cases individual device functions may not be available. In some cases it is also not possible to restore the original state by resetting to the "as-delivered" state.

The **Duplicate** option should always be used to copy the configuration to another device.

12.8 Protecting settings from unauthorized access

The settings can be protected from unauthorized access in two ways:

- Locking via parameters (software locking)
- Locking via write protection switch (hardware locking)

13 Diagnostics and troubleshooting

13.1 General troubleshooting

13.1.1 General errors

Error	Possible cause	Solution
Device does not respond.	Supply voltage does not match the value indicated on the nameplate.	Connect the correct voltage.
	The polarity of the supply voltage is wrong.	Correct the polarity.
	The cables do not contact the terminals properly.	Ensure electrical contact between the cable and the terminal.
Values on the display invisible	Contrast setting is too weak or too strong.	<ul style="list-style-type: none"> ■ Increase contrast by pressing \boxplus and \boxminus simultaneously. ■ Decrease contrast by pressing \boxminus and \boxplus simultaneously.
	The plug of the display cable is not connected correctly.	Connect the plug correctly.
	Display is defective.	Replace display.
"Communication error" is indicated on the display when starting the device or connecting the display.	Electromagnetic interference	Check grounding of the device.
	Broken display cable or display plug.	Replace display.
Duplication of parameters via display from one device to another not working. Only the "Save" and "Cancel" options are available.	Display with backup is not properly detected if a data backup was not carried out on the new device previously.	Connect display (with backup) and restart device.
Output current <3.6 mA	Signal cable connection incorrect.	Check connection.
	Electronics module is defective.	Replace electronics.
HART communication does not function.	Communication resistor missing or incorrectly installed.	Install the communication resistor (250 Ω) correctly.
	Commubox is connected incorrectly.	Connect Commubox correctly.
	Commubox is not set to "HART".	Set Commubox selector switch to "HART".
CDI communication does not work.	Wrong setting of the COM port on the computer.	Check the setting of the COM port on the computer and change it if necessary.
Device measures incorrectly.	Parameter configuration error	Check and correct the parameter configuration.
No communication with device via SmartBlue	No Bluetooth connection	Enable Bluetooth function on smartphone or tablet
	The device is already connected with another smartphone/tablet	Disconnect the device from the other smartphone/tablet
	Bluetooth module not connected	Connect Bluetooth module (see SD02252F).
Login via SmartBlue not possible	Device is being put into operation for the first time	Enter initial password (ID of Bluetooth module) and change it





Error	Possible cause	Solution
Device cannot be operated via SmartBlue	Incorrect password entered	Enter the correct password, paying attention to lower/upper case
Device cannot be operated via SmartBlue	Password forgotten	Contact Endress+Hauser Service (www.addresses.endress.com)

13.1.2 Error - SmartBlue operation

Error	Possible cause	Solution
Device is not visible in the live list	No Bluetooth connection	Enable Bluetooth® function on smartphone or tablet
		Bluetooth® function of sensor disabled, perform recovery sequence
Device is not visible in the live list	The device is already connected with another smartphone/tablet	Only one point-to-point connection is established between a sensor and a smartphone or tablet
Device is visible in the live list but cannot be accessed via SmartBlue	Android end device	Is the location function permitted for the app, was it approved the first time?
		GPS or positioning function must be activated for certain Android versions in conjunction with Bluetooth®
		Activate GPS - close the app fully and restart - enable the positioning function for the app
Device is visible in the live list but cannot be accessed via SmartBlue	Apple end device	Log in as standard Enter user name "admin" Enter initial password (ID of Bluetooth module), paying attention to lower/upper case
Login via SmartBlue not possible	Device is being put into operation for the first time	Enter initial password (ID of Bluetooth module) and change, paying attention to lower/upper case
Device cannot be operated via SmartBlue	Incorrect password entered	Enter the correct password, paying attention to lower/upper case
Device cannot be operated via SmartBlue	Password forgotten	contact Endress+Hauser Service (www.addresses.endress.com)

13.1.3 Parameter configuration errors

Parameter configuration errors for level measurements

Error	Possible cause	Solution
Measured value is incorrect	If measured distance (Setup → Distance) matches the real distance: Calibration error	<ul style="list-style-type: none"> ▪ Check the Empty calibration parameter (→  108) and correct if necessary. ▪ Check the Full calibration parameter (→  108) and correct if necessary. ▪ Check the linearization and correct if necessary (Linearization submenu (→  122)).
	If measured distance (Setup → Distance) does not match the real distance: An interference echo is present.	Carry out mapping (Confirm distance parameter (→  111)).
No change of measured value on filling/emptying	An interference echo is present.	Carry out mapping (Confirm distance parameter (→  111)).
	Buildup at the probe.	Clean the probe.

Error	Possible cause	Solution
	Error in the echo tracking	Deactivate echo tracking (Expert → Sensor → Echo tracking → Evaluation mode = History off).
Echo lost diagnostic message appears after the supply voltage is switched on.	Echo threshold too high.	Check the Medium group parameter (→ 107). If necessary, select a more detailed setting with the Medium property parameter (→ 116).
	Level echo suppressed.	Delete the map and record it again if necessary (Record map parameter (→ 112)).
Device displays a level when the tank is empty.	Incorrect probe length	Perform a probe length correction (Confirm probe length parameter (→ 137)).
	Interference echo	Carry out mapping over the entire probe length when the tank is empty (Confirm distance parameter (→ 111)).
Wrong slope of the level over the entire measuring range	Wrong tank type selected.	Select the correct Tank type parameter (→ 106).

13.2 Diagnostic information on local display

13.2.1 Diagnostic message

Faults detected by the self-monitoring system of the measuring instrument are displayed as a diagnostic message in alternation with the measured value display.

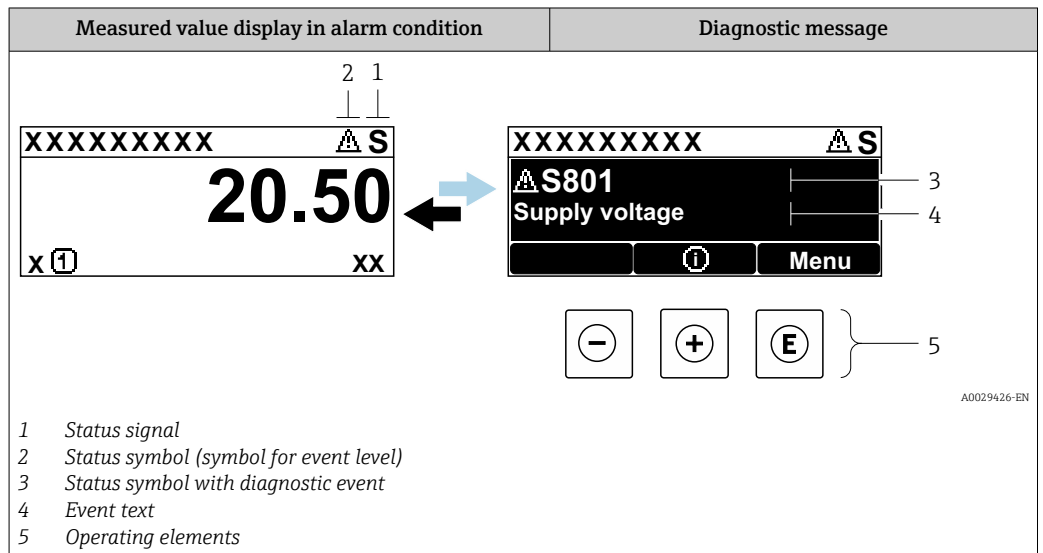

Status signals

F <small>A0032902</small>	"Failure (F)" option A device error has occurred. The measured value is no longer valid.
C <small>A0032903</small>	"Function check (C)" option The device is in the service mode (e.g. during a simulation).

S <small>A0032904</small>	<p>"Out of specification (S)" option</p> <p>The device is operated:</p> <ul style="list-style-type: none"> ▪ Outside its technical specifications (e.g. during startup or cleaning) ▪ Outside the configuration performed by the user (e.g. level outside the configured range)
M <small>A0032905</small>	<p>"Maintenance required (M)" option</p> <p>Maintenance is required. The measured value is still valid.</p>

Status symbols (symbol for event level)

⊗	<p>"Alarm" status</p> <p>Measurement is interrupted. The signal outputs adopt the defined alarm state. A diagnostic message is generated.</p>
⚠	<p>"Warning" status</p> <p>The device continues to measure. A diagnostic message is generated.</p>

Diagnostic event and event text

The fault can be identified by means of the diagnostic event. The event text helps you by providing information about the fault. In addition, the associated status symbol is displayed in front of the diagnostic event.

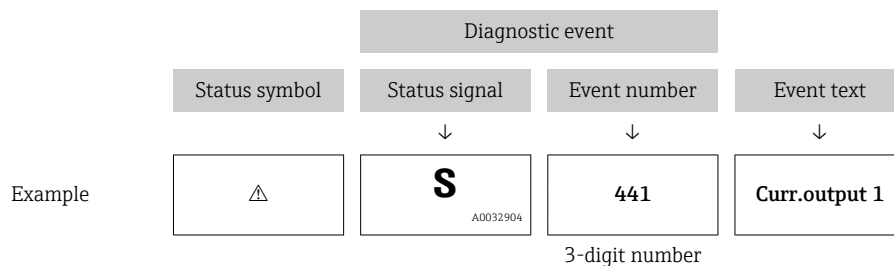

If several diagnostic events are pending at the same time, only the diagnostic message with the highest priority is displayed. Additional queued diagnostic messages can be shown in the **Diagnostic list** submenu.

- i** Past diagnostic messages that are no longer pending are shown as follows:
 - On the local display:
 - in the **Event logbook** submenu
 - In FieldCare:
 - via the "Event List/HistoROM" function

Operating elements

Operating functions in menu, submenu	
+	<p>Plus key</p> <p>Opens the message about the remedial measures.</p>
E	<p>Enter key</p> <p>Opens the operating menu.</p>

13.2.2 Calling up remedial measures

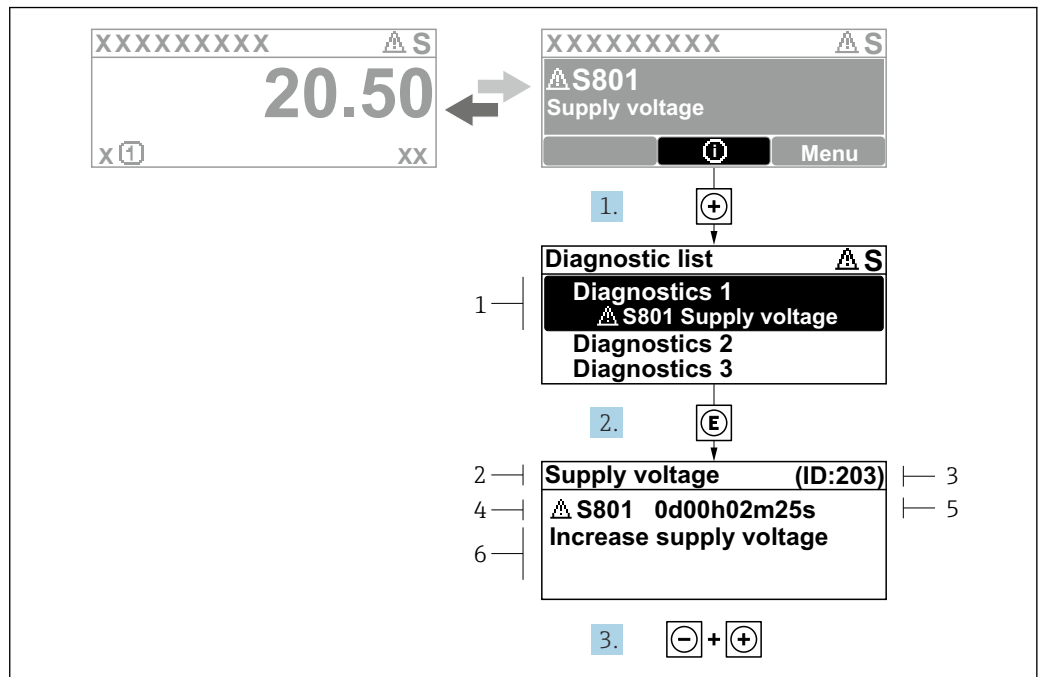

33 Message for remedial measures

- 1 Diagnostic information
- 2 Short text
- 3 Service ID
- 4 Diagnostic behavior with diagnostic code
- 5 Operation time when error occurred
- 6 Remedial measures

The user is in the diagnostic message.

1. Press ⊕ (⊕ symbol).
 - ↳ The **Diagnostic list** submenu opens.
2. Select the desired diagnostic event with ⊕ or ⊖ and press ⊕ .
 - ↳ The message for the remedial measures for the selected diagnostic event opens.
3. Press ⊖ + ⊕ simultaneously.
 - ↳ The message about the remedial measures closes.

The user is in the **Diagnostics** menu at an entry for a diagnostics event, e.g. in **Diagnostic list** or in **Previous diagnostics**.

1. Press ⊕ .
 - ↳ The message for the remedial measures for the selected diagnostic event opens.
2. Press ⊖ + ⊕ simultaneously.
 - ↳ The message about the remedial measures closes.

13.3 Diagnostic event in the operating tool

If a diagnostic event has occurred in the device, the status signal appears in the top left status area of the operating tool together with the corresponding symbol for the event level according to NAMUR NE 107:

- Failure (F)
- Function check (C)
- Out of specification (S)
- Maintenance required (M)

A: Via the operating menu

1. Navigate to the **Diagnostics** menu.
 - ↳ In the **Actual diagnostics** parameter, the diagnostic event is shown with event text.
2. On the right in the display area, hover the cursor over the **Actual diagnostics** parameter.

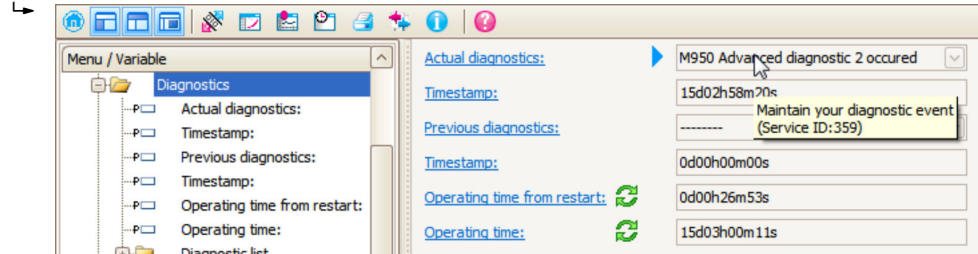

A tool tip with remedy information for the diagnostic event appears.

B: Via the "Create Documentation" function

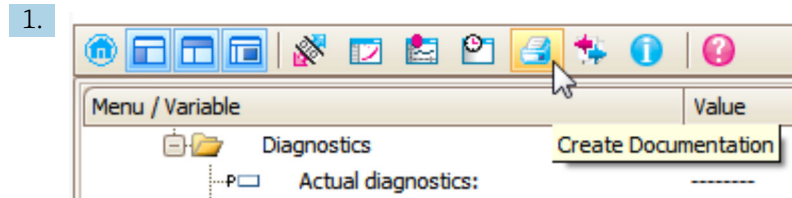

Select the "Create documentation" function.

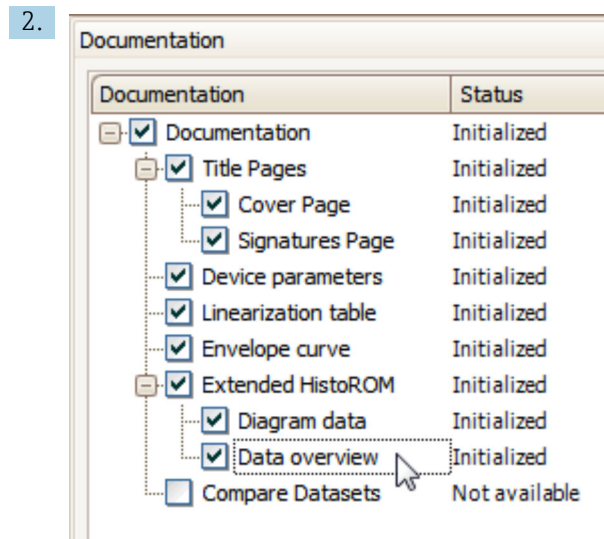

Make sure that "Data overview" is marked.

3. Click "Save as..." and save a PDF of the report.
 - ↳ The report contains the diagnostic messages including remedial measures.

C: Via the "Event list/Extended HistoROM" function

1.

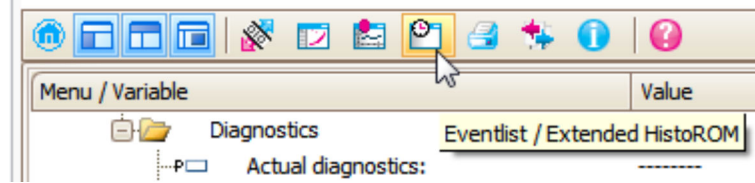

Select the ("Event list/Extended HistoROM") function.

2.

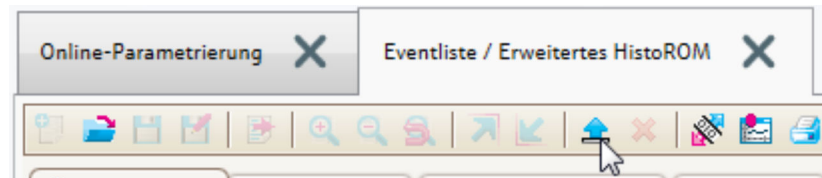

Select the "Load event list" function.

- ↳ The event list including remedial measures is displayed in the "Data overview" window.

13.4 Diagnostic list

In the **Diagnostic list** submenu submenu, up to 5 currently pending diagnostic messages can be displayed. If more than 5 messages are pending, the messages with the highest priority are shown on the display.

Navigation path

Diagnostics → Diagnostic list

Calling up and closing the remedial measures

1. Press \square .

- ↳ The message for the remedial measures for the selected diagnostic event opens.

2. Press \square + \oplus simultaneously.

- ↳ The message about the remedial measures closes.

13.5 List of diagnostic events

Diagnostic number	Short text	Remedy instructions	Status signal [from the factory]	Diagnostic behavior [from the factory]
Diagnostic of sensor				
003	Broken probe detected	1. Check map 2. Check sensor	F	Alarm
046	Build-up detected	Clean sensor	F	Alarm
104	HF cable	and check sealing 1. Dry HF cable connection 2. Change HF cable	F	Alarm
105	HF cable	1. Tighten HF cable connection 2. Check sensor 3. Change HF cable	F	Alarm
106	Sensor	1. Check sensor 2. Check HF cable 3. Contact service	F	Alarm
Diagnostic of electronic				
242	Software incompatible	1. Check software 2. Flash or change main electronics module	F	Alarm
252	Modules incompatible	1. Check if correct electronic modul is plugged 2. Replace electronic module	F	Alarm
261	Electronic modules	1. Restart device 2. Check electronic modules 3. Change I/O Modul or main electronics	F	Alarm
262	Module connection	1. Check module connections 2. Change electronic modules	F	Alarm
270	Main electronic failure	Change main electronic module	F	Alarm
271	Main electronic failure	1. Restart device 2. Change main electronic module	F	Alarm
272	Main electronic failure	1. Restart device 2. Contact service	F	Alarm
273	Main electronic failure	1. Emergency operation via display 2. Change main electronics	F	Alarm
275	I/O module defective	Change I/O module	F	Alarm
276	I/O module faulty	1. Restart device 2. Change I/O module	F	Alarm
276	I/O module faulty		F	Alarm
282	Data storage	1. Restart device 2. Contact service	F	Alarm
283	Memory content	1. Transfer data or reset device 2. Contact service	F	Alarm
311	Electronic failure	Maintenance required! 1. Do not perform reset 2. Contact service	M	Warning
Diagnostic of configuration				
410	Data transfer	1. Check connection 2. Retry data transfer	F	Alarm
411	Up-/download active	Up-/download active, please wait	C	Warning
412	Processing download	Download active, please wait	C	Warning

Diagnostic number	Short text	Remedy instructions	Status signal [from the factory]	Diagnostic behavior [from the factory]
431	Trim 1 to 2	Carry out trim	C	Warning
435	Linearization	Check linearization table	F	Alarm
437	Configuration incompatible	1. Restart device 2. Contact service	F	Alarm
438	Dataset	1. Check data set file 2. Check device configuration 3. Up- and download new configuration	M	Warning
441	Current output 1 to 2	1. Check process 2. Check current output settings	S	Warning
484	Failure mode simulation	Deactivate simulation	C	Alarm
485	Simulation measured value	Deactivate simulation	C	Warning
491	Current output 1 to 2 simulation	Deactivate simulation	C	Warning
494	Switch output simulation	Deactivate simulation switch output	C	Warning
495	Diagnostic event simulation	Deactivate simulation	C	Warning
585	Simulation distance	Deactivate simulation	C	Warning
Diagnostic of process				
801	Energy too low	Increase supply voltage	S	Warning
803	Current loop	1. Check wiring 2. Change I/O module	F	Alarm
825	Operating temperature	1. Check ambient temperature 2. Check process temperature	S	Warning
825	Operating temperature		F	Alarm
921	Change of reference	1. Check reference configuration 2. Check pressure 3. Check sensor	S	Warning
936	EMC interference	Check installation on EMC	F	Alarm
941	Echo lost	Check parameter 'DC value'	F	Alarm ¹⁾
942	In safety distance	1. Check level 2. Check safety distance 3. Reset self holding	S	Alarm ¹⁾
943	In blocking distance	Reduced accuracy Check level	S	Warning
944	Level range	Reduced accuracy Level at process connection	S	Warning
950	Advanced diagnostic 1 to 2 occurred	Maintain your diagnostic event	M	Warning ¹⁾

1) Diagnostic behavior can be changed.

13.6 Event logbook

13.6.1 Event history

A chronological overview of the event messages that have occurred is provided in the **Event list**

(This submenu only exists if operating via the local display. In the case of operation via FieldCare, the event list can be displayed with the "Event list/HistoROM" functionality of FieldCare.

Navigation path

Diagnostics → Event logbook → Event list

A maximum of 100 event messages can be displayed in chronological order.



The event history includes entries for:

- Diagnostic events
- Information events

In addition to the operating time when the event occurred, each event is also assigned a symbol that indicates whether the event has occurred or is finished:

- Diagnostic event
 - ☹: Occurrence of the event
 - ☺: End of the event
- Information event
 - ☹: Occurrence of the event

Calling up and closing the remedial measures

1. Press .
 - ↳ The message for the remedial measures for the selected diagnostic event opens.
2. Press  +  simultaneously.
 - ↳ The message about the remedial measures closes.

13.6.2 Filtering the event logbook

Using the **Filter options** parameter, you can define which category of event messages is displayed in the **Event list** submenu.

Navigation path

Diagnostics → Event logbook → Filter options

Filter categories

- All
- Failure (F)
- Function check (C)
- Out of specification (S)
- Maintenance required (M)
- Information

13.6.3 Overview of information events

Info number	Info name
I1000	----- (Device ok)
I1089	Power on
I1090	Configuration reset
I1091	Configuration changed

Info number	Info name
I1092	Embedded HistoROM deleted
I1110	Write protection switch changed
I1137	Electronic changed
I1151	History reset
I1154	Reset terminal voltage min/max
I1155	Reset electronic temperature
I1156	Memory error trend
I1157	Memory error event list
I1184	Display connected
I1185	Display backup done
I1186	Restore via display done
I1187	Settings downloaded with display
I1188	Display data cleared
I1189	Backup compared
I1256	Display: access status changed
I1264	Safety sequence aborted
I1335	Firmware changed
I1397	Fieldbus: access status changed
I1398	CDI: access status changed
I1512	Download started
I1513	Download finished
I1514	Upload started
I1515	Upload finished
I1554	Safety sequence started
I1555	Safety sequence confirmed
I1556	Safety mode off

13.7 Firmware history

Date	Firmware version	Modifications	Documentation (FMP53, HART)		
			Operating Instructions	Description of Device Parameters	Technical Information
07.2010	01.00.zz	Original software	BA01002F/00/EN/05.10	GP01000F/00/EN/05.10	TI01002F/00/EN/05.10
01.2011	01.01.zz	<ul style="list-style-type: none"> ▪ SIL integrated ▪ Improvements and bugfixes ▪ Additional languages 	<ul style="list-style-type: none"> ▪ BA01002F/00/EN/10.10 ▪ BA01002F/00/EN/13.11 ▪ BA01002F/00/EN/14.12 	<ul style="list-style-type: none"> ▪ GP01000F/00/EN/10.10 ▪ GP01000F/00/EN/13.11 	<ul style="list-style-type: none"> ▪ TI01002F/00/EN/10.10 ▪ TI01002F/00/EN/13.11 ▪ TI01002F/00/EN/14.12 ▪ TI01002F/00/EN/15.12

Date	Firmware version	Modifications	Documentation (FMP53, HART)		
			Operating Instructions	Description of Device Parameters	Technical Information
02.2014	01.02.zz	<ul style="list-style-type: none"> ▪ Support of SD03 ▪ Additional languages ▪ HistoROM functionality enhanced ▪ "Advanced Diagnostics" function block integrated ▪ Improvements and bugfixes 	<ul style="list-style-type: none"> ▪ BA01002F/00/EN/15.13 ▪ BA01002F/00/EN/16.14 	<ul style="list-style-type: none"> ▪ GP01000F/00/EN/14.13 ▪ GP01000F/00/EN/15.14 	<ul style="list-style-type: none"> ▪ TI01002F/00/EN/16.13 ▪ TI01002F/00/EN/17.14
04.2016	01.03.zz	<ul style="list-style-type: none"> ▪ Update to HART 7 ▪ All 17 languages are available in the device ▪ Improvements and bugfixes 	<ul style="list-style-type: none"> ▪ BA01002F/00/EN/17.16 ▪ BA01002F/00/EN/18.16¹⁾ ▪ BA01002F/00/EN/20.18²⁾ 	GP01000F/00/EN/16.16	<ul style="list-style-type: none"> ▪ TI01002F/00/EN/18.16 ▪ TI01002F/00/EN/20.16¹⁾ ▪ TI01002F/00/EN/22.18²⁾

1) Contains information on the Heartbeat wizards available in the current DTM version for DeviceCare and. FieldCare

2) Contains information on the Bluetooth interface.



The firmware version can explicitly be ordered via the product structure. In this way it is possible to ensure compatibility of the firmware version with an existing or planned system integration.

14 Maintenance

No special maintenance work is required.

14.1 Exterior cleaning

When cleaning the exterior, always use cleaning agents that do not corrode the surface of the housing and the seals.

14.2 General cleaning instructions

Dirt or buildup may form on the probe depending on the application. A thin, even layer has little impact on the measurement. Thick layers can dampen the signal and reduce the measuring range. Very uneven deposit formation or caking (e.g. due to crystallization) can result in incorrect measurements. In such cases, use a non-contact measuring principle, or regularly inspect the probe for contamination.

Cleaning with sodium hydroxide solution (e.g. in CIP procedures): if the coupling is wetted, larger measurement errors can occur than under reference operating conditions. Wetting can cause temporary incorrect measurements.

14.3 Cleaning the probe

14.3.1 Cleaning the probe in the vessel

If a suitable mounting position has been selected, the probe can be cleaned using a spray ball in the vessel →  20.

14.3.2 Cleaning the probe outside the vessel

The probe can be disassembled to facilitate cleaning.

The following tools are required for cleaning:

- Vice with fiber protective jaws (surface protection of polished probe rod)
- Hook wrench with nose ϕ 54 mm (2.1 in)
- Open-ended wrench AF27/AF32 with torque adjustment up to 20 Nm

Caution!

- Before starting work, make sure that the power supply for the device is switched off.
- When unscrewing the slotted nut (1), you must use an open-ended wrench to counterhold the process connection ring (5). Otherwise the adapter (3) will become detached from the flange.

Disassembling the electronics housing

- Loosen the slotted nut (1) using the hook wrench.
- Pull the loosened housing (2) together with the housing bracket upwards from the adapter (3) of the process connection. The housing bracket remains attached to the housing. Place the housing to the side. Remove only the cable adapter in the "Sensor, remote" version.
- Replace the O-ring (7) if necessary.
Order number: see Device Viewer → 78

Disassembling the rod probe

- Unscrew the adapter (3) from the process connection (flange in the example): Using an open-ended wrench (AF27), unscrew the adapter at the wrench flat and pull it out of the vessel together with the probe rod (max. 4 m).
- Clamp the probe rod (4) at the wrench flat or use a pair of pliers.

Caution: Make sure the surface of the polished probe rod is protected! It must not be damaged by scratches or dents.

- Unscrew the adapter (3) from the probe rod (turning left for approx. 12 rotations) and remove (plug-in connection). The probe rod is screwed into the insulating socket with 4.5 Nm.
- The O-ring seals (6) on the probe rod and on the adapter are now freely accessible and can be replaced if necessary. The probe rod and adapter can be autoclaved.
Order number of the O-rings: see Device Viewer → 78

Probe mounting

Assembly is the reverse of the disassembly sequence:

- Screw the adapter (3) onto the probe rod (4) with 4.5 Nm.
- Screw the adapter together with the probe rod into the vessel process connection and tighten it with 20 Nm.
- Attach the housing (2) with the housing bracket to the adapter and screw on with the slotted nut (1); torque 20 Nm.

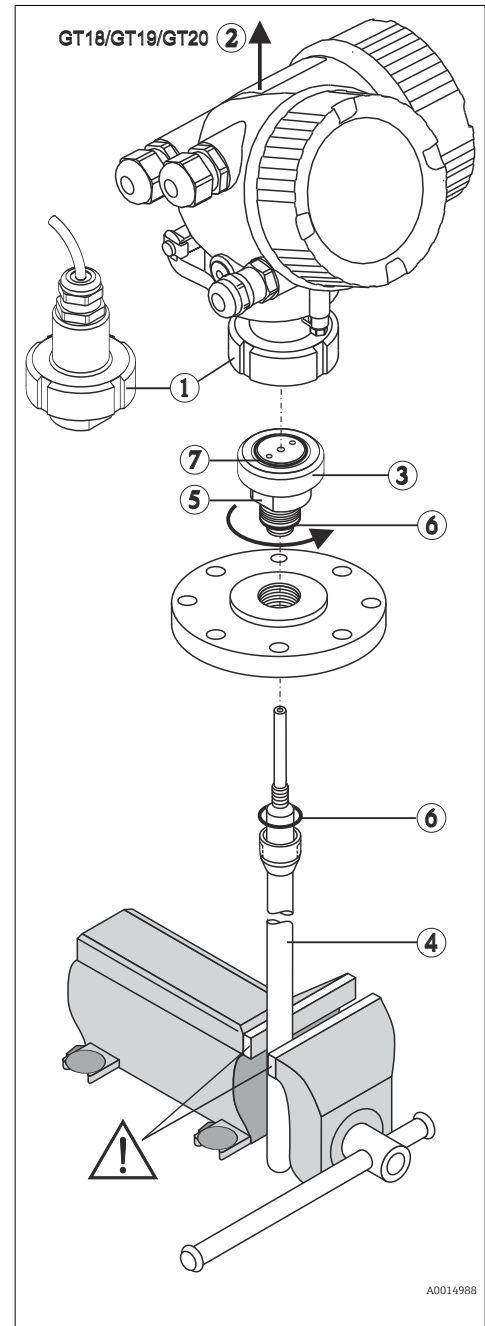

15 Repair

15.1 General information

15.1.1 Repair concept

Under the Endress+Hauser repair concept, devices have a modular design and repairs can be carried out by Endress+Hauser Service or by properly trained customers.

Spare parts are grouped into logical kits with the associated replacement instructions.

For more information on service and spare parts, please contact Endress+Hauser Service.

15.1.2 Repairs to Ex-approved devices

WARNING

Incorrect repair can compromise electrical safety!

Explosion hazard!

- ▶ Repairs to Ex-approved devices must be carried out by Endress+Hauser Service or by specialist personnel according to national regulations.
- ▶ Relevant standards and national regulations on hazardous areas, safety instructions and certificates must be observed.
- ▶ Use only original Endress+Hauser spare parts.
- ▶ Please note the device designation on the nameplate. Only identical parts may be used as replacements.
- ▶ Carry out repairs according to the instructions.
- ▶ Only the Endress+Hauser service team is permitted to modify a certified device and convert it to another certified version.

15.1.3 Replacing electronics modules

When electronics modules have been replaced the device does not need to be recalibrated as the parameters are saved in the HistoROM inside the housing. It may be necessary when replacing the main electronics to record a new interference echo suppression.

15.1.4 Replacing a device

Once a complete device has been replaced, the parameters can be transferred back into the device using one of the following methods:

- Using the display module
Prerequisite: The configuration of the old device was saved previously to the display module.
- Via FieldCare
Prerequisite: The configuration of the old device was saved previously to the computer using FieldCare.

You can continue measuring without performing a new calibration. Only interference echo suppression may need to be carried out once again.

15.2 Spare parts

- Some replaceable measuring instrument components are identified by means of a spare part nameplate. This contains information about the spare part.
- In the connection compartment cover of the device there is a spare part nameplate which contains the following information:
 - A list of the most important spare parts for the measuring instrument, including their ordering information.
 - The URL to the *W@M Device Viewer* (www.endress.com/deviceviewer):
All the spare parts for the measuring instrument, along with the order code, are listed here and can be ordered. If available, users can also download the associated Installation Instructions.

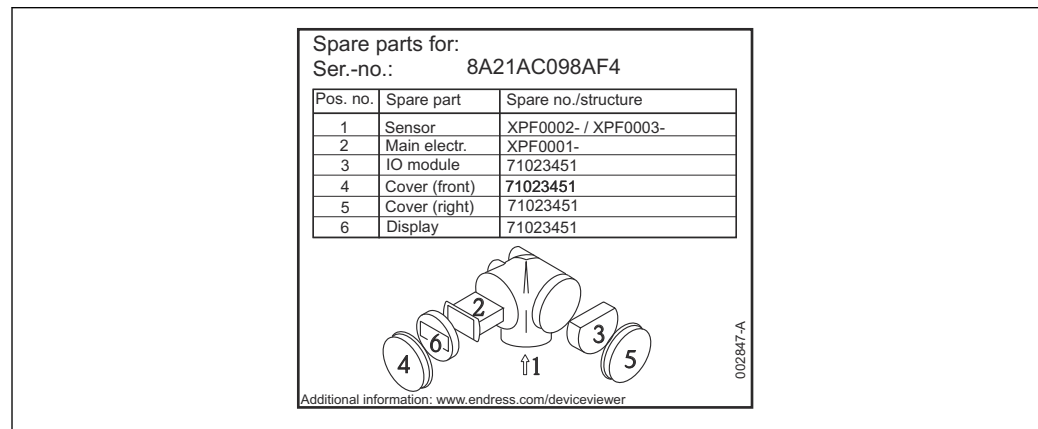

34 Example for spare part nameplate in the connection compartment cover

- i** Measuring instrument serial number:
 - Located on the device and spare part nameplate.
 - Can be read out via the "Serial number" parameter in the "Device information" submenu.

15.3 Return

The requirements for safe device return can vary depending on the device type and national legislation.

1. Refer to the web page for information:
<https://www.endress.com/support/return-material>
↳ Select the region.
2. If returning the device, pack the device in such a way that it is reliably protected against impact and external influences. The original packaging offers the best protection.

15.4 Disposal

-  If required by the Directive 2012/19/EU on waste electrical and electronic equipment (WEEE), the product is marked with the depicted symbol in order to minimize the disposal of WEEE as unsorted municipal waste. Do not dispose of products bearing this marking as unsorted municipal waste. Instead, return them to the manufacturer for disposal under the applicable conditions.

16 Accessories

The accessories currently available for the product can be selected at www.endress.com:

1. Select the product using the filters and search field.
2. Open the product page.
3. Select **Spare parts & Accessories**.

16.1 Device-specific accessories

16.1.1 Weather protection cover

The weather protection cover can be ordered together with the device via the "Accessory enclosed" product structure.

It is used to protect against direct sunlight, precipitation and ice.

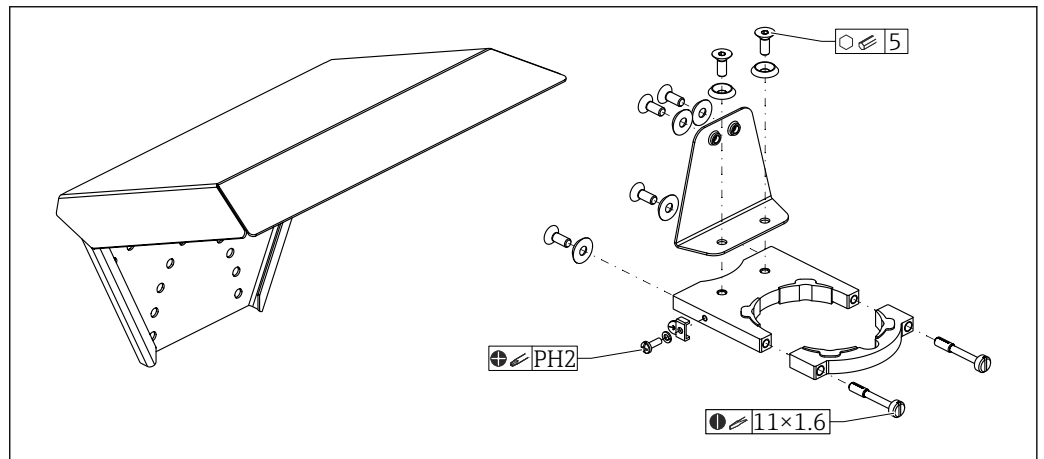

A0051672

35 Overview

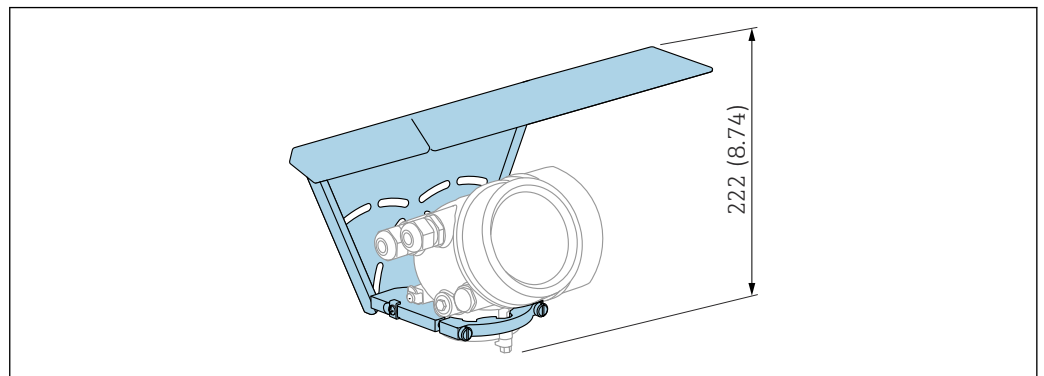

A0015466

36 Height. Unit of measurement mm (in)

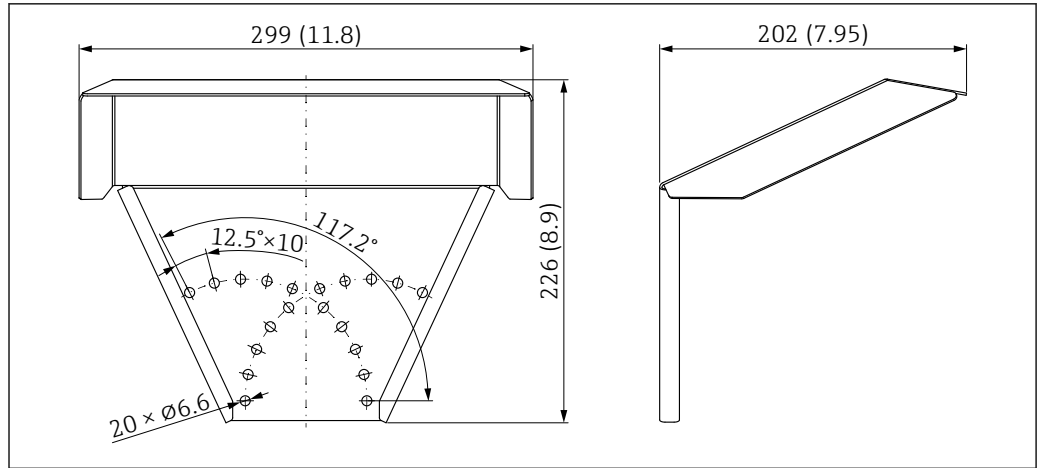

A0015472

37 Dimensions. Unit of measurement mm (in)

Material

- Protection cap; 316L (1.4404)
- Bracket; 316L (1.4404)
- Angle bracket; 316L (1.4404)
- Clamping screw; 316L (1.4404) + carbon fiber
- Molded rubber part (4x); EPDM
- Screws; A4
- Disks; A4
- Ground terminal; A4, 316L (1.4404)

Order number for accessories:

71162242

16.1.2 Mounting bracket for electronics housing

With "remote sensor" device versions (feature 060 in the product structure), the mounting bracket is included in the scope of delivery. It can be ordered as a separate accessory .

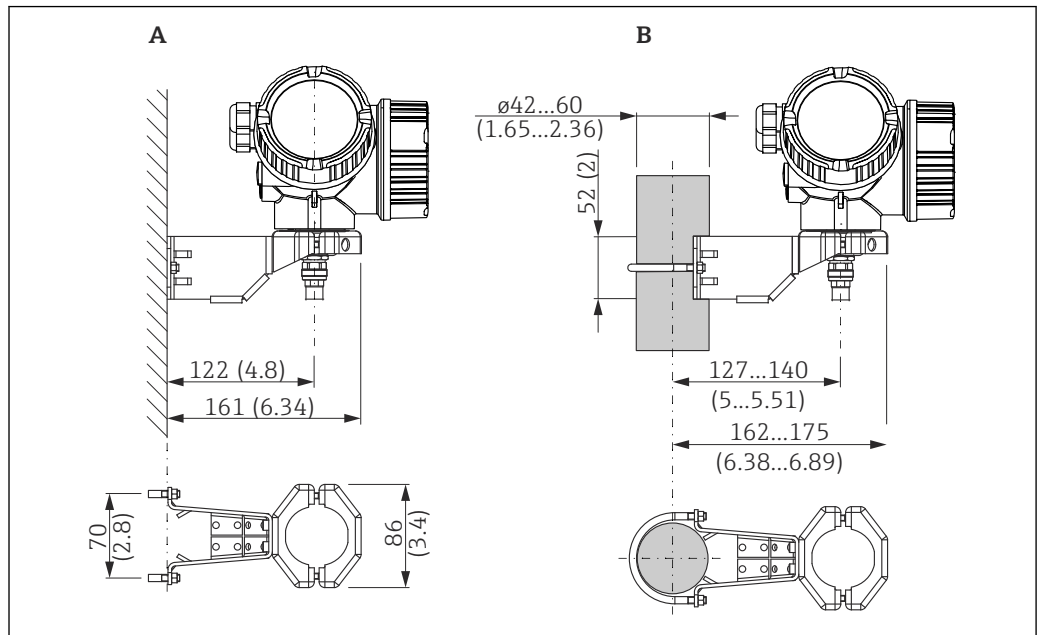

A0014793

38 Mounting bracket for electronics housing; unit: mm (in)

A Wall mounting

B Post mounting

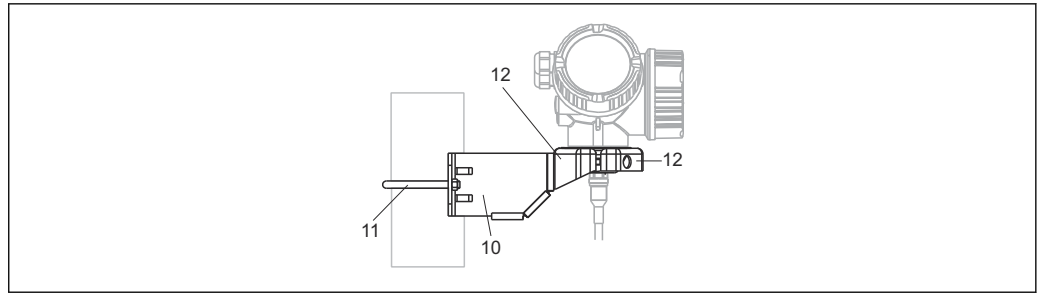

A0015143

39 Material; mounting bracket

- 10 Bracket, 316L (1.4404)
- 11 Round bracket, 316L (1.4404); screws/nuts, A4-70; distance sleeves, 316L (1.4404)
- 12 Half-shells, 316 L (1.4404)

Order number for accessories:

71102216

16.1.3 Weld-in adapter

With M24x1.5 thread for flush-mounted installation of sensor.

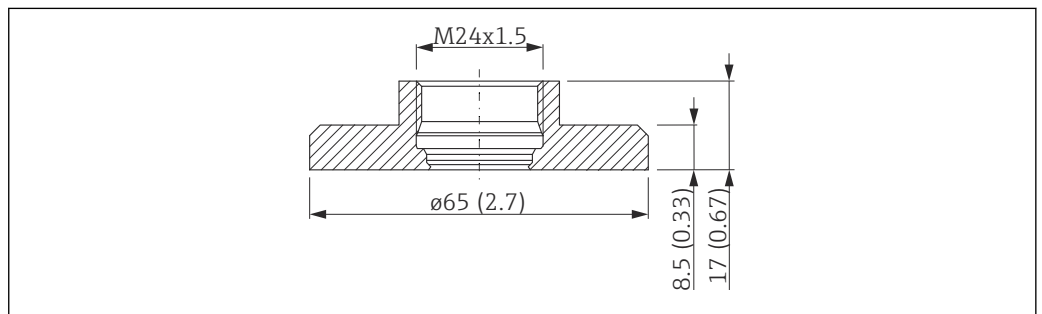

A0012776

40 Dimensions, weld-in adapter

- Material: 1.4435 (AISI 316L)
- Weight: 0.22 kg (0.48 lbs)

Order number for accessories:

- Standard version: 71041381
- With 3.1 material certificate: 71041383

 For details, see Operating Instructions BA00361F

16.1.4 Protective cover

For closing off the probe when the electronics module is removed

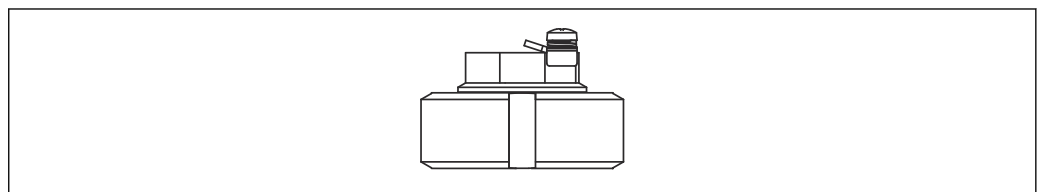

A0013589

Order number for accessories:

71041379



For details, see Operating Instructions BA00362F.

16.1.5 Calibration kit

The calibration kit is used for regular testing of the accuracy and reproducibility of the device.

Order number for accessories:

71041382

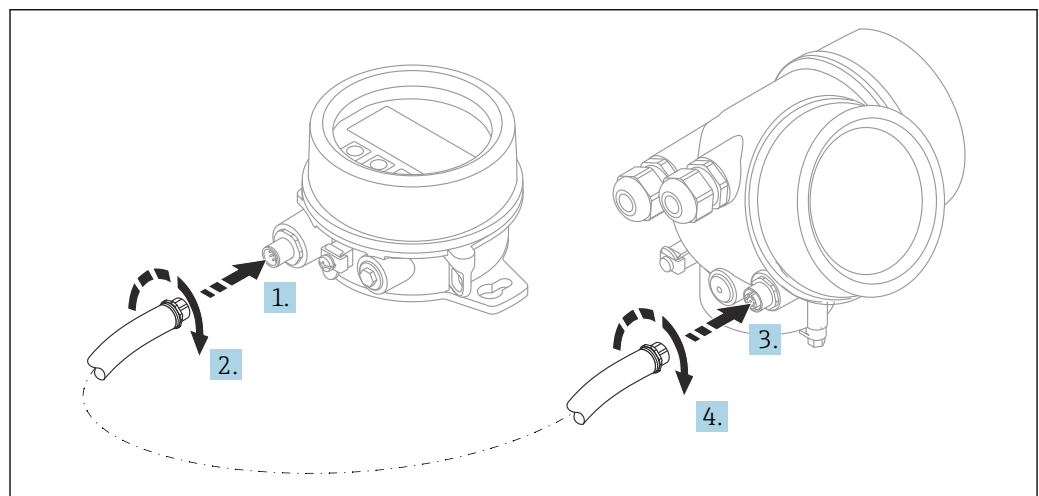

For details, see SD01003F.

16.1.6 Remote display FHX50

A0019128

Technical data

- Material:
 - Plastic PBT
 - 316L/1.4404
 - Aluminum
 - Degree of protection: IP68 / NEMA 6P and IP66 / NEMA 4x
 - Suitable for display modules:
 - SD02 (push buttons)
 - SD03 (touch control)
 - Connecting cable:
 - Cable supplied with device up to 30 m (98 ft)
 - Standard cable provided by customer onsite up to 60 m (196 ft)
 - Ambient temperature: -40 to 80 °C (-40 to 176 °F)
 - Ambient temperature, optionally available for order. -50 to 80 °C (-58 to 176 °F)
- NOTICE** If the temperature is permanently below -40 °C (-40 °F), higher failure rates can be expected.

Ordering information

- If the remote display is to be used, the device version "Prepared for display FHX50" must be ordered.

For FHX50, the option "Prepared for display FHX50" must be selected under "Measuring device version".

- If a measuring instrument has not been ordered with the version "Prepared for display FHX50" and is to be retrofitted with an FHX50, the version "Not prepared for display FHX50" must be ordered for the FHX50 under "Measuring device version". In this case, a retrofit kit for the device is supplied with the FHX50. The kit can be used to prepare the device so that the FHX50 can be used.

-  Use of the FHX50 may be restricted for transmitters with an approval. A device can only be retrofitted with the FHX50 if the option "Prepared for FHX50" is listed under *Basic specifications*, "Display, operation" in the Safety instructions (XA) for the device.

Also refer to the Safety Instructions (XA) of the FHX50.

Retrofitting is not possible on transmitters with:

- An approval for use in areas with flammable dust (dust ignition-proof approval)
- Type of protection Ex nA

-  For details, see "Special Documentation" document SD01007F.

16.1.7 Overvoltage protection

The surge arrester for loop-powered devices can be ordered together with the device via the "Accessory mounted" section of the product order structure.

The surge arrester can be used for loop-powered devices.

- 1-channel devices - OVP10
- 2-channel devices - OVP20

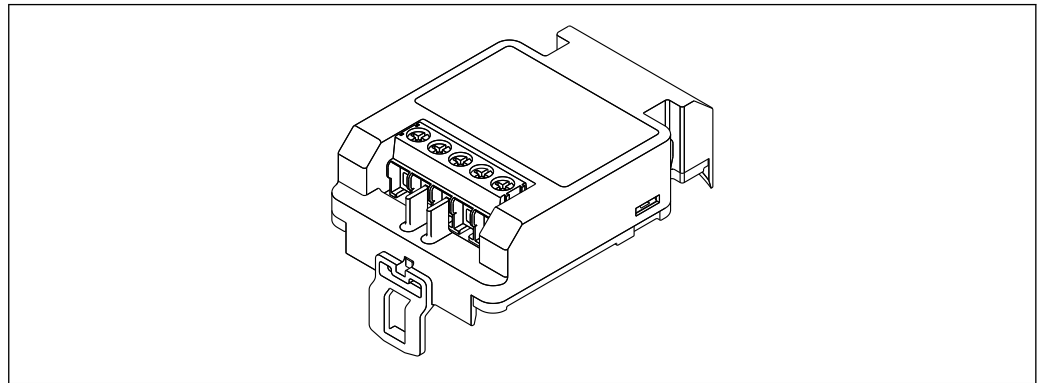

A0021734

Technical data

- Resistance per channel: $2 \times 0.5 \Omega_{\max}$
- Threshold DC voltage: 400 to 700 V
- Threshold surge voltage: < 800 V
- Capacitance at 1 MHz: < 1.5 pF
- Nominal leakage current (8/20 μ s): 10 kA
- Suitable for conductor cross-sections: 0.2 to 2.5 mm² (24 to 14 AWG)

If retrofitting:

- Order number for 1-channel devices (OVP10): 71128617
- Order number for 2-channel devices (OVP20): 71128619
- The use of the OVP module may be restricted depending on the transmitter approval. A device may only be retrofitted with the OVP module if the option *NA* (overvoltage protection) is listed under *Optional specifications* in the Safety Instructions (XA) associated with the device.
- In order to keep the necessary safety distances when using the surge arrester module, the housing cover also needs to be replaced when the device is retrofitted. Depending on the housing type, the suitable cover can be ordered using the following order number:
 - Housing GT18: 71185516
 - Housing GT19: 71185518
 - Housing GT20: 71185517



For details, see the "Special Documentation" SD01090F

16.1.8 Bluetooth module BT10 for HART devices

The Bluetooth module BT10 can be ordered together with the device via the "Accessory mounted" section of the product order structure.

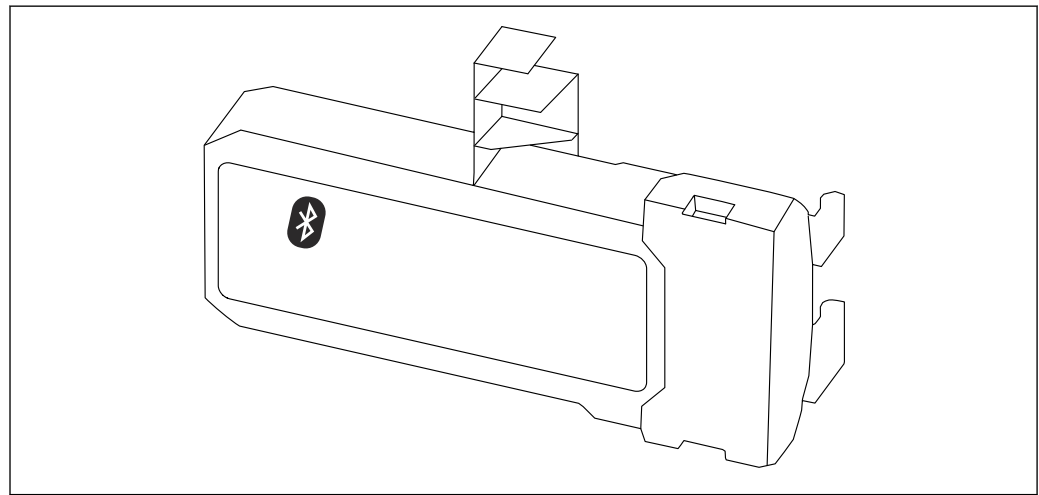

A0036493

Technical data

- Quick and easy setup with the SmartBlue app
- No additional tools or adapters needed
- Signal curve via SmartBlue (app)
- Encrypted single point-to-point data transmission (tested by Fraunhofer Institute) and password-protected communication via Bluetooth® wireless technology
- Range under reference conditions:
 - > 10 m (33 ft)
- When the Bluetooth module is used, the minimum supply voltage of the device increases by up to 3 V.

If retrofitting:

- Order number: 71377355
- The use of the Bluetooth module may be restricted depending on the transmitter approval. A device may only be retrofitted with the Bluetooth module if the option *NF* (Bluetooth module) is listed under *Optional specifications* in the Safety Instructions (XA) associated with the device.



For details, see the "Special Documentation" SD02252F

16.2 Communication-specific accessories

Commubox FXA195 HART

For intrinsically safe HART communication with FieldCare via the USB interface

 For details, see "Technical Information" TI00404F

Commubox FXA291

Connects Endress+Hauser field devices with a CDI interface (= Endress+Hauser Common Data Interface) and the USB port of a computer or laptop

Order number: 51516983

 For details, see "Technical Information" TI00405C

HART Loop Converter HMX50

Is used to evaluate and convert dynamic HART process variables to analog current signals or limit values

Order number: 71063562

 For details, see "Technical Information" TI00429F and Operating Instructions BA00371F

WirelessHART adapter SWA70

- Is used for the wireless connection of field devices
- The WirelessHART adapter can be easily integrated into field devices and existing infrastructures, offers data protection and transmission safety and can be operated in parallel with other wireless networks

 For details, see Operating Instructions BA00061S

Fieldgate FXA42

Fieldgates enable communication between connected 4 to 20 mA, Modbus RS485 and Modbus TCP devices and SupplyCare Hosting or SupplyCare Enterprise. The signals are transmitted either via Ethernet TCP/IP, WLAN or mobile communications (UMTS). Advanced automation capabilities are available, such as an integrated Web-PLC, OpenVPN and other functions.

 For details, see "Technical Information" TI01297S and Operating Instructions BA01778S.

SupplyCare Enterprise SCE30B

Inventory management software that displays the level, volume, mass, temperature, pressure, density or other parameters of tanks. The parameters are recorded and transmitted by means of gateways like Fieldgate FXA42, Connect Sensor FXA30B or other gateway types.

This Web-based software is installed on a local server and can also be visualized and operated with mobile terminals such as a smartphone or tablet.

 For details, see Technical Information TI01228S and Operating Instructions BA00055S

SupplyCare Hosting SCH30

Inventory management software that displays the level, volume, mass, temperature, pressure, density or other parameters of tanks. The parameters are recorded and transmitted by means of gateways like Fieldgate FXA42, Connect Sensor FXA30B or other gateway types.

SupplyCare Hosting is offered as a hosting service (Software as a Service, SaaS). In the Endress+Hauser portal, the user is provided with the data over the Internet.

 For details, see Technical Information TI01229S and Operating Instructions BA00050S

Field Xpert SFX350

Field Xpert SFX350 is a mobile computer for commissioning and maintenance. It enables efficient device configuration and diagnostics for HART and FOUNDATION Fieldbus devices in the **non-Ex area**.



For details, see Operating Instructions BA01202S

Field Xpert SFX370

Field Xpert SFX370 is a mobile computer for commissioning and maintenance. It enables efficient device configuration and diagnostics for HART and FOUNDATION Fieldbus devices in the **non-Ex area** and the **Ex area**.



For details, see Operating Instructions BA01202S

16.3 Service-specific accessories

DeviceCare SFE100

Configuration tool for HART, PROFIBUS and FOUNDATION Fieldbus field devices



Technical Information TI01134S

FieldCare SFE500

FDT-based plant asset management tool

It can configure all smart field units in your system and helps you manage them. By using the status information, it is also a simple but effective way of checking their status and condition.



Technical Information TI00028S

16.4 System components

16.4.1 Memograph M RSG45

The Advanced Data Manager is a flexible and powerful system for organizing process values.

The Memograph M is used for electronic acquisition, display, recording, analysis, remote transmission and archiving of analog and digital input signals as well as calculated values.



Technical Information TI01180R and Operating Instructions BA01338R

16.4.2 RN42

Single-channel active barrier with wide-range power supply for safe electrical isolation of 4 to 20 mA standard signal circuits, HART transparent.















































Technical Information TI01584K and Operating Instructions BA02090K

17 Operating menu

17.1 Overview of the operating menu (SmartBlue)

Navigation  SmartBlue

Setup	→  106
Device tag	→  106
Distance unit	→  106
Tank type	→  106
Tube diameter	→  107
Medium group	→  107
Empty calibration	→  108
Full calibration	→  108
Level	→  109
Distance	→  109
Signal quality	→  110
Confirm distance	→  111
Present mapping	→  112
Mapping end point	→  112
Record map	→  112
► Advanced setup	→  114
Locking status	→  114
Access status tooling	→  114
Enter access code	→  115
► Level	→  116
Medium type	→  116

Medium property	→  116
Process property	→  117
Advanced process conditions	→  118
Level unit	→  119
Blocking distance	→  119
Level correction	→  120
► Linearization	→  122
Linearization type	→  124
Unit after linearization	→  125
Free text	→  126
Level linearized	→  127
Maximum value	→  127
Diameter	→  127
Intermediate height	→  128
Table mode	→  128
Table number	→  129
Level	→  129
Level	→  130
Customer value	→  130
Activate table	→  130
► Probe settings	→  136
Probe grounded	→  136
Present probe length	→  136
Confirm probe length	→  137























▶ Safety settings	→ 131
Output echo lost	→ 131
Value echo lost	→ 131
Ramp at echo lost	→ 132
Blocking distance	→ 119
▶ Current output 1 to 2	→ 140
Assign current output	→ 140
Current span	→ 141
Fixed current	→ 141
Damping output	→ 142
Failure mode	→ 142
Failure current	→ 143
Output current 1 to 2	→ 143
▶ Switch output	→ 144
Switch output function	→ 144
Assign status	→ 145
Assign limit	→ 145
Assign diagnostic behavior	→ 145
Switch-on value	→ 146
Switch-on delay	→ 147
Switch-off value	→ 147
Switch-off delay	→ 148
Failure mode	→ 148

	Switch status	→ 148
	Invert output signal	→ 148
Diagnostics		→ 162
	Actual diagnostics	→ 162
	Timestamp	→ 162
	Previous diagnostics	→ 162
	Timestamp	→ 163
	Operating time from restart	→ 163
	Operating time	→ 156
	► Diagnostic list	→ 164
	Diagnostics 1 to 5	→ 164
	Timestamp 1 to 5	→ 164
	► Measured values	→ 169
	Distance	→ 109
	Level linearized	→ 127
	Output current 1 to 2	→ 143
	Measured current 1	→ 170
	Terminal voltage 1	→ 170
	► Device information	→ 166
	Device tag	→ 166
	Serial number	→ 166
	Firmware version	→ 166
	Device name	→ 166
	Order code	→ 167
	Extended order code 1 to 3	→ 167

Device revision	→ 167
Device ID	→ 167
Device type	→ 168
Manufacturer ID	→ 168
► Simulation	→ 175
Assign measurement variable	→ 176
Process variable value	→ 176
Current output 1 to 2 simulation	→ 176
Value current output 1 to 2	→ 177
Switch output simulation	→ 177
Switch status	→ 177
Device alarm simulation	→ 178

17.2 Overview of the operating menu (display module)

Navigation  Operating menu

























Language		
Setup		→  106
Device tag		→  106
Distance unit		→  106
Tank type		→  106
Tube diameter		→  107
Medium group		→  107
Empty calibration		→  108
Full calibration		→  108
Level		→  109
Distance		→  109
Signal quality		→  110
► Mapping		→  113
Confirm distance		→  113
Mapping end point		→  113
Record map		→  113
Distance		→  113
► Advanced setup		→  114
Locking status		→  114
Access status display		→  115
Enter access code		→  115
► Level		→  116
Medium type		→  116



Medium property	→ 116
Process property	→ 117
Advanced process conditions	→ 118
Level unit	→ 119
Blocking distance	→ 119
Level correction	→ 120
► Linearization	→ 122
Linearization type	→ 124
Unit after linearization	→ 125
Free text	→ 126
Maximum value	→ 127
Diameter	→ 127
Intermediate height	→ 128
Table mode	→ 128
► Edit table	
Level	
Customer value	
Activate table	→ 130
► Safety settings	→ 131
Output echo lost	→ 131
Value echo lost	→ 131
Ramp at echo lost	→ 132
Blocking distance	→ 119
► SIL/WHG confirmation	→ 134

▶ Deactivate SIL/WHG	→ 135
Reset write protection	→ 135
Code incorrect	→ 135
▶ Probe settings	→ 136
Probe grounded	→ 136
▶ Probe length correction	→ 138
Confirm probe length	→ 138
Present probe length	→ 136
▶ Current output 1 to 2	→ 140
Assign current output	→ 140
Current span	→ 141
Fixed current	→ 141
Damping output	→ 142
Failure mode	→ 142
Failure current	→ 143
Output current 1 to 2	→ 143
▶ Switch output	→ 144
Switch output function	→ 144
Assign status	→ 145
Assign limit	→ 145
Assign diagnostic behavior	→ 145
Switch-on value	→ 146
Switch-on delay	→ 147
Switch-off value	→ 147
Switch-off delay	→ 148

Failure mode	→ 148
Switch status	→ 148
Invert output signal	→ 148
► Display	→ 150
Language	→ 150
Format display	→ 150
Value 1 to 4 display	→ 152
Decimal places 1 to 4	→ 152
Display interval	→ 152
Display damping	→ 153
Header	→ 153
Header text	→ 153
Separator	→ 154
Number format	→ 154
Decimal places menu	→ 154
Backlight	→ 154
Contrast display	→ 155
► Configuration backup display	→ 156
Operating time	→ 156
Last backup	→ 156























Configuration management	→ 156
Comparison result	→ 157
▶ Administration	→ 159
▶ Define access code	→ 161
Define access code	→ 161
Confirm access code	→ 161
Device reset	→ 159
🔍 Diagnostics	→ 162
Actual diagnostics	→ 162
Previous diagnostics	→ 162
Operating time from restart	→ 163
Operating time	→ 156
▶ Diagnostic list	→ 164
Diagnostics 1 to 5	→ 164
▶ Event logbook	→ 165
Filter options	
▶ Event list	→ 165
▶ Device information	→ 166
Device tag	→ 166
Serial number	→ 166
Firmware version	→ 166
Device name	→ 166
Order code	→ 167
Extended order code 1 to 3	→ 167
Device revision	→ 167

























Device ID	→  167
Device type	→  168
Manufacturer ID	→  168
▶ Measured values	→  169
Distance	→  109
Level linearized	→  127
Output current 1 to 2	→  143
Measured current 1	→  170
Terminal voltage 1	→  170
▶ Data logging	→  171
Assign channel 1 to 4	→  171
Logging interval	→  172
Clear logging data	→  172
▶ Display channel 1 to 4	→  173
▶ Simulation	→  175
Assign measurement variable	→  176
Process variable value	→  176
Current output 1 to 2 simulation	→  176
Value current output 1 to 2	→  177
Switch output simulation	→  177
Switch status	→  177
Device alarm simulation	→  178
▶ Device check	→  179
Start device check	→  179
Result device check	→  179

Last check time	→  179
Level signal	→  180
Launch signal	→  180





















17.3 Overview of the operating menu (operating tool)

























Navigation  Operating menu

























Setup	→  106
Device tag	→  106
Distance unit	→  106
Tank type	→  106
Tube diameter	→  107
Medium group	→  107
Empty calibration	→  108
Full calibration	→  108
Level	→  109
Distance	→  109
Signal quality	→  110
Confirm distance	→  111
Present mapping	→  112
Mapping end point	→  112
Record map	→  112
► Advanced setup	→  114
Locking status	→  114
Access status tooling	→  114
Enter access code	→  115
► Level	→  116
Medium type	→  116
Medium property	→  116
Process property	→  117

Advanced process conditions	→  118
Level unit	→  119
Blocking distance	→  119
Level correction	→  120
► Linearization	→  122
Linearization type	→  124
Unit after linearization	→  125
Free text	→  126
Level linearized	→  127
Maximum value	→  127
Diameter	→  127
Intermediate height	→  128
Table mode	→  128
Table number	→  129
Level	→  129
Level	→  130
Customer value	→  130
Activate table	→  130
► Safety settings	→  131
Output echo lost	→  131
Value echo lost	→  131
Ramp at echo lost	→  132
Blocking distance	→  119
► SIL/WHG confirmation	→  134

▶ Deactivate SIL/WHG	→ 135
Reset write protection	→ 135
Code incorrect	→ 135
▶ Probe settings	→ 136
Probe grounded	→ 136
Present probe length	→ 136
Confirm probe length	→ 137
▶ Current output 1 to 2	→ 140
Assign current output	→ 140
Current span	→ 141
Fixed current	→ 141
Damping output	→ 142
Failure mode	→ 142
Failure current	→ 143
Output current 1 to 2	→ 143
▶ Switch output	→ 144
Switch output function	→ 144
Assign status	→ 145
Assign limit	→ 145
Assign diagnostic behavior	→ 145
Switch-on value	→ 146
Switch-on delay	→ 147
Switch-off value	→ 147
Switch-off delay	→ 148
Failure mode	→ 148





Switch status	→  148
Invert output signal	→  148
► Display	→  150
Language	→  150
Format display	→  150
Value 1 to 4 display	→  152
Decimal places 1 to 4	→  152
Display interval	→  152
Display damping	→  153
Header	→  153
Header text	→  153
Separator	→  154
Number format	→  154
Decimal places menu	→  154
Backlight	→  154
Contrast display	→  155
► Configuration backup display	→  156
Operating time	→  156
Last backup	→  156
Configuration management	→  156

Backup state	→  157
Comparison result	→  157
▶ Administration	→  159
Define access code	
Device reset	→  159
 Diagnostics	→  162
Actual diagnostics	→  162
Timestamp	→  162
Previous diagnostics	→  162
Timestamp	→  163
Operating time from restart	→  163
Operating time	→  156
▶ Diagnostic list	→  164
Diagnostics 1 to 5	→  164
Timestamp 1 to 5	→  164
▶ Device information	→  166
Device tag	→  166
Serial number	→  166
Firmware version	→  166
Device name	→  166
Order code	→  167
Extended order code 1 to 3	→  167
Device revision	→  167
Device ID	→  167

Device type	→  168
Manufacturer ID	→  168
► Measured values	→  169
Distance	→  109
Level linearized	→  127
Output current 1 to 2	→  143
Measured current 1	→  170
Terminal voltage 1	→  170
► Data logging	→  171
Assign channel 1 to 4	→  171
Logging interval	→  172
Clear logging data	→  172
► Simulation	→  175
Assign measurement variable	→  176
Process variable value	→  176
Current output 1 to 2 simulation	→  176
Value current output 1 to 2	→  177
Switch output simulation	→  177
Switch status	→  177
Device alarm simulation	→  178
► Device check	→  179
Start device check	→  179
Result device check	→  179
Last check time	→  179



Level signal	→ 180
Launch signal	→ 180
▶ Heartbeat	→ 181

17.4 "Setup" menu



-   : Indicates how to navigate to the parameter using the display and operating module
-  : Indicates how to navigate to the parameter using operating tools (e.g. FieldCare)
-  : Indicates parameters that can be locked via the access code.

Navigation   Setup



Device tag

- Navigation**   Setup → Device tag
- Description** Enter a unique name for the measuring point to identify the device quickly within the plant.
- User entry** Character string comprising numbers, letters and special characters (32)

Distance unit



- Navigation**   Setup → Distance unit
- Description** Used for the basic calibration (Empty / Full).
- Selection**
- | | |
|--|---|
| <p><i>SI units</i></p> <ul style="list-style-type: none"> ▪ mm ▪ m | <p><i>US units</i></p> <ul style="list-style-type: none"> ▪ ft ▪ in |
|--|---|

Tank type





- Navigation**   Setup → Tank type
- Prerequisite** **Medium type** (→  116) = **Liquid**
- Description** Select tank type.
- Selection**
- Metallic
 - Bypass / pipe
 - Non metallic
 - Mounted outside
 - Coaxial
- Factory setting** Depending on the probe

- Additional information**
- Depending on the probe some of the options mentioned above may not be available or there may be additional options.
 - For coax probes and probes with metallic center washer **Tank type** parameter corresponds to the type of probe and cannot be changed.



Tube diameter 

- Navigation**   Setup → Tube diameter
- Prerequisite** **Tank type** (→  106) = **Bypass / pipe**
- Description** Specify diameter of bypass or stilling well.
- User entry** 0 to 9.999 m

Medium group 

- Navigation**   Setup → Medium group
- Prerequisite** **Medium type** (→  116) = **Liquid**
- Description** Select medium group.
- Selection**
- Others
 - Water based (DC >= 4)
- Additional information** This parameter roughly specifies the dielectric constant (DC) of the medium. For a more detailed definition of the DC use the **Medium property** parameter (→  116).
The **Medium group** parameter presets the **Medium property** parameter (→  116) as follows:

Medium group	Medium property (→  116)
Others	Unknown
Water based (DC >= 4)	DC 4 ... 7

-  The **Medium property** parameter can be changed at a later point of time. However, when doing so, the **Medium group** parameter retains its value. Only the **Medium property** parameter is relevant for the signal evaluation.
-  The measuring range may be reduced for small dielectric constants. For details refer to the Technical Information (TI) of the respective device.

Empty calibration

**Navigation** Setup → Empty calibr.**Description**

Distance between process connection and minimum level (0%).

User entry

Depending on the probe

Factory setting

Depending on the probe

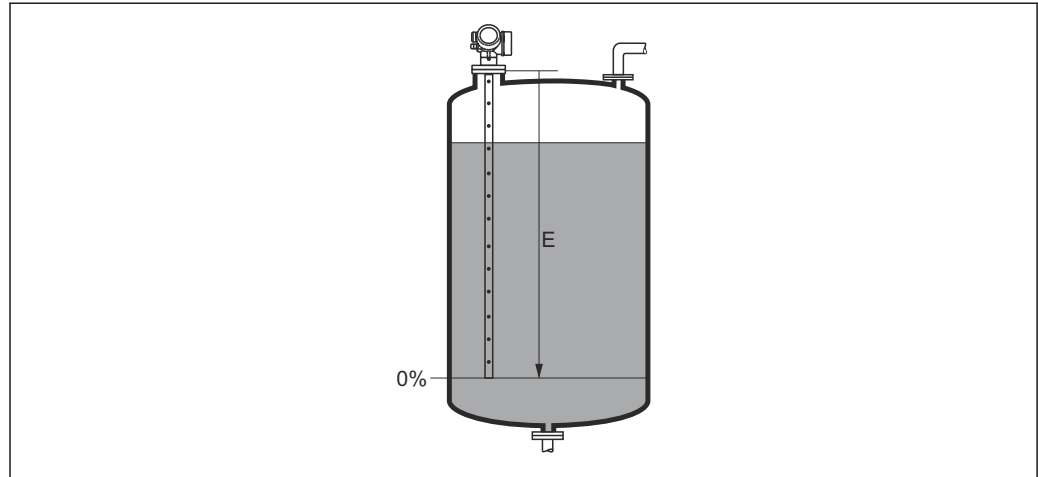
Additional information

A0013178

 41 *Empty calibration (E) for level measurements in liquids*

Full calibration

**Navigation** Setup → Full calibr.**Description**

Distance between minimum level (0%) and maximum level (100%).

User entry

Depending on the probe

Factory setting

Depending on the probe

Additional information

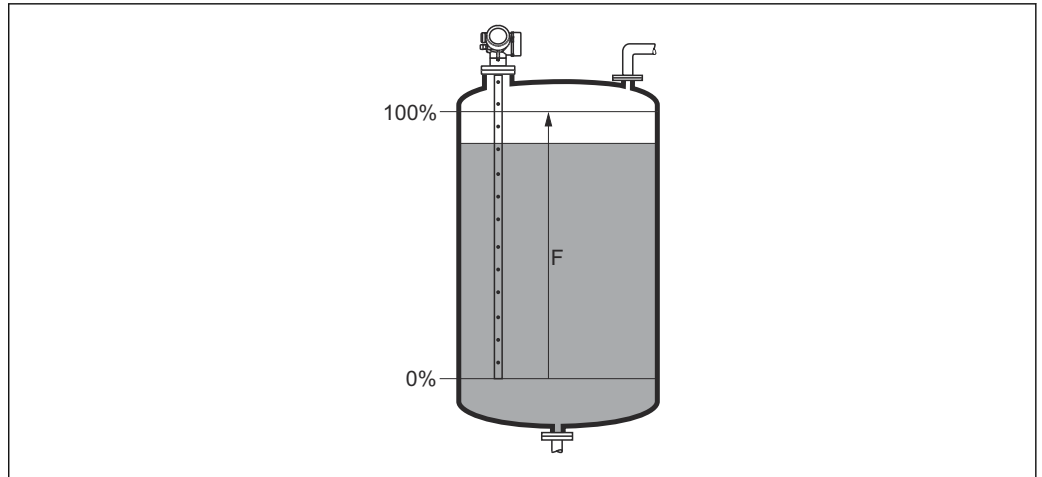

A0013186

42 Full calibration (F) for level measurements in liquids

Level

Navigation

Setup → Level

Description

Displays measured level L_L (before linearization).

Additional information

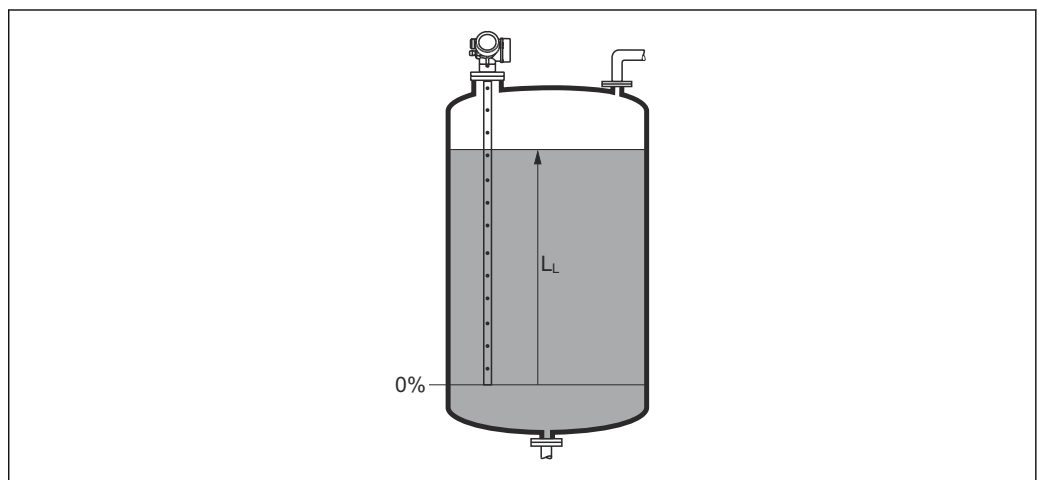

A0013194

43 Level in case of liquid measurements

i The unit is defined in the **Level unit** parameter (→ 119).

Distance

Navigation

Setup → Distance

Description

Displays the measured distance D_L between the reference point (lower edge of the flange or threaded connection) and the level.

Additional information

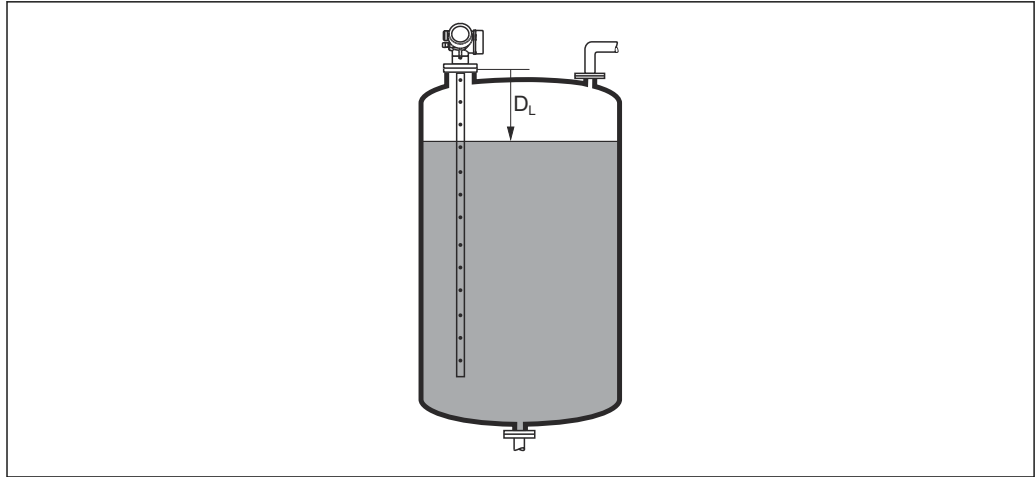

A0013196

44 Distance for liquid measurements

i The unit is defined in the **Distance unit** parameter (→ 106).

Signal quality

Navigation

Setup → Signal quality

Description

Displays the signal quality of the evaluated echo.

Additional information

Meaning of the display options

- **Strong**
The evaluated echo exceeds the threshold by at least 10 mV.
- **Medium**
The evaluated echo exceeds the threshold by at least 5 mV.
- **Weak**
The evaluated echo exceeds the threshold by less than 5 mV.
- **No signal**
The device does not find a usable echo.

The signal quality indicated in this parameter always refers to the currently evaluated echo: either the level/interface echo ¹⁾ or the end-of-probe echo. To differentiate between these two, the quality of the end-of-probe echo is always displayed in brackets.

i In case of a lost echo (**Signal quality = No signal**) the device generates the following error message:

- F941, for **Output echo lost** (→ 131) = **Alarm**.
- S941, if another option has been selected in **Output echo lost** (→ 131).

1) Of these two echos the one with the lower quality is indicated.

Confirm distance
**Navigation**

Setup → Confirm distance

Description

Specify, whether the measured distance matches the real distance.
Depending on the selection the device automatically sets the range of mapping.

Selection

- Manual map
- Distance ok
- Distance unknown
- Distance too small^{*}
- Distance too big^{*}
- Tank empty
- Delete map

Additional information**Meaning of the options**

- **Manual map**
To be selected if the range of mapping is to be defined manually in the **Mapping end point** parameter (→ 112). In this case it is not necessary to confirm the distance.
 - **Distance ok**
To be selected if the measured distance matches the actual distance. The device performs a mapping.
 - **Distance unknown**
To be selected if the actual distance is unknown. A mapping can not be performed in this case.
 - **Distance too small**
To be selected if the measured distance is smaller than the actual distance. The device searches for the next echo and returns to the **Confirm distance** parameter. The distance is recalculated and displayed. The comparison must be repeated until the displayed distance matches the actual distance. After this, the recording of the map can be started by selecting **Distance ok**.
 - **Distance too big**²⁾
To be selected if the measured distance exceeds the actual distance. The device adjusts the signal evaluation and returns to the **Confirm distance** parameter. The distance is recalculated and displayed. The comparison must be repeated until the displayed distance matches the actual distance. After this, the recording of the map can be started by selecting **Distance ok**.
 - **Tank empty**
To be selected if the tank is completely empty. The device records a mapping covering the complete measuring range.
To be selected if the tank is completely empty. The device records a mapping covering the complete measuring range minus **Map gap to LN**.
 - **Factory map**
To be selected if the present mapping curve (if one exists) is to be deleted. The device returns to the **Confirm distance** parameter and a new mapping can be recorded.
- When operating via the display module, the measured distance is displayed together with this parameter for reference purposes.
- If the teaching procedure with the **Distance too small** option or the **Distance too big** option is quit before the distance has been confirmed, a map is **not** recorded and the teaching procedure is reset after 60 s.





* Visibility depends on order options or device settings

2) Only available for "Expert → Sensor → Echo tracking → **Evaluation mode** parameter" = "Short time history" or "Long time history"





Present mapping

Navigation	 Setup → Present mapping
Description	Indicates up to which distance a mapping has already been recorded.



Mapping end point

Navigation	 Setup → Map. end point
Prerequisite	Confirm distance (→  111) = Manual map or Distance too small
Description	Specify new end of the mapping.
User entry	0 to 200 000.0 m
Additional information	<p>This parameter defines up to which distance the new mapping is to be recorded. The distance is measured from the reference point, i.e. from the lower edge of the mounting flange or the threaded connection.</p> <p> For reference purposes the Present mapping parameter (→  112) is displayed together with this parameter. It indicates up to which distance a mapping has already been recorded.</p>

Record map

Navigation	 Setup → Record map
Prerequisite	Confirm distance (→  111) = Manual map or Distance too small
Description	Start recording of the map.
Selection	<ul style="list-style-type: none"> ■ No ■ Record map ■ Delete map
Additional information	<p>Meaning of the options</p> <ul style="list-style-type: none"> ■ No The map is not recorded. ■ Record map The map is recorded. After the recording is completed, the new measured distance and the new mapping range appear on the display. When operating via the local display, these values must be confirmed by pressing . ■ Delete map The mapping (if one exists) is deleted and the device displays the recalculated measured distance and the mapping range. When operating via the local display, these values must be confirmed by pressing .

17.4.1 "Mapping" wizard

-  The **Mapping** wizard is only available when operating via the local display. When operating via an operating tool, all parameters concerning the mapping are located directly in the **Setup** menu (→  106).
-  In the **Mapping** wizard two parameters are displayed simultaneously on the display module at any one time. The upper parameter can be edited, whereas the lower parameter is displayed for reference purposes only.

Navigation  Setup → Mapping

Confirm distance

Navigation  Setup → Mapping → Confirm distance

Description →  111

Mapping end point

Navigation  Setup → Mapping → Map. end point

Description →  112

Record map

Navigation  Setup → Mapping → Record map

Description →  112

Distance





Navigation  Setup → Mapping → Distance

Description →  109





17.4.2 "Advanced setup" submenu

Navigation  Setup → Advanced setup





Locking status

Navigation	  Setup → Advanced setup → Locking status
Description	Indicates the write protection with the highest priority that is currently active.
User interface	<ul style="list-style-type: none"> ■ Hardware locked ■ SIL locked ■ CT active - defined parameters ■ WHG locked ■ Temporarily locked
Additional information	<p>Meaning and priorities of the types of write protection</p> <ul style="list-style-type: none"> ■ Hardware locked (priority 1) The DIP switch for hardware locking is activated on the main electronics module. This locks write access to the parameters. ■ SIL locked (priority 2) The SIL mode is activated. Writing access to the relevant parameters is denied. ■ WHG locked (priority 3) The WHG mode is activated. Writing access to the relevant parameters is denied. ■ Temporarily locked (priority 4) Write access to the parameters is temporarily locked on account of internal processes in progress in the device (e.g. data upload/download, reset etc.). The parameters can be modified as soon as the processes are complete. <p> On the display module, the -symbol appears in front of parameters that cannot be modified since they are write-protected.</p>





Access status tooling

Navigation	 Setup → Advanced setup → Access stat.tool
Description	Shows the access authorization to the parameters via the operating tool.
Additional information	<p> The access authorization can be changed via the Enter access code parameter (→  115).</p> <p> If additional write protection is active, this restricts the current access authorization even further. The write protection status can be viewed via the Locking status parameter (→  114).</p>

Access status display

Navigation	 Setup → Advanced setup → Access stat.disp
Prerequisite	The device has a local display.
Description	Indicates access authorization to parameters via local display.
Additional information	<p> The access authorization can be changed via the Enter access code parameter (→  115).</p> <p> If additional write protection is active, this restricts the current access authorization even further. The write protection status can be viewed via the Locking status parameter (→  114).</p>



Enter access code

Navigation	 Setup → Advanced setup → Ent. access code
Description	Enter access code to disable write protection of parameters.
User entry	0 to 9999
Additional information	<ul style="list-style-type: none"> ▪ The customer-specific access code that was defined in the Define access code parameter (→  159) must be entered for local operation. ▪ If an incorrect access code is entered, users retain their current access authorization. ▪ The write protection affects all parameters marked with the  symbol in the document. On the local display, the  symbol in front of a parameter indicates that the parameter is write-protected. ▪ If no key is pressed for 10 minutes or the user goes from the navigation and editing mode back to the measured value display mode, the device automatically locks the write-protected parameters after another 60 s. <p> Please contact your Endress+Hauser Sales Center if you lose your access code.</p>



"Level" submenu

Navigation  Setup → Advanced setup → Level

Medium type 

Navigation	 Setup → Advanced setup → Level → Medium type
Description	Specify type of medium.
User interface	<ul style="list-style-type: none"> ▪ Liquid ▪ Solid
Factory setting	FMP50, FMP51, FMP52, FMP53, FMP54, FMP55: Liquid
Additional information	 This parameter determines the value of several other parameters and strongly influences the complete signal evaluation. Therefore, it is strongly recommended not to change the factory setting.

Medium property 

Navigation	 Setup → Advanced setup → Level → Medium property
Prerequisite	EOP level evaluation ≠ Fix DC
Description	Specify the dielectric constant ϵ_r of the medium.
Selection	<ul style="list-style-type: none"> ▪ Unknown ▪ DC 1.4 ... 1.6 ▪ DC 1.6 ... 1.9 ▪ DC 1.9 ... 2.5 ▪ DC 2.5 ... 4 ▪ DC 4 ... 7 ▪ DC 7 ... 15 ▪ DC > 15
Factory setting	Depends on the Medium type (→  116) and Medium group (→  107) parameters.

Additional information

Dependency of "Medium type" and "Medium group"

Medium type (→ ⓘ 116)	Medium group (→ ⓘ 107)	Medium property
Solid		Unknown
Liquid	Water based (DC >= 4)	DC 4 ... 7
	Others	Unknown

i For the relative permittivity values (ϵ_r values) of many media commonly used in industry, please refer to:

- Relative permittivity (ϵ_r value), Compendium CP01076F
- The Endress+Hauser "DC Values app" (available for Android and iOS)

i If **EOP level evaluation = Fix DC**, the exact dielectric constant must be specified in the **DC value** parameter. The **Medium property** parameter therefore does not apply in this case.

Process property



Navigation

☰☰ Setup → Advanced setup → Level → Process property

Description

Specify typical rate of level change.

Selection

For "Medium type" = "Liquid"

- Very fast > 10 m (400 in)/min
- Fast > 1 m (40 in)/min
- Standard < 1 m (40in) /min
- Medium < 10 cm (4in) /min
- Slow < 1 cm (0.4in) /min
- No filter / test

For "Medium type" = "Solid"

- Very fast > 100 m (333 ft) /h
- Fast > 10 m (33 ft) /h
- Standard < 10 m (33 ft) /h
- Medium < 1 m (3ft) /h
- Slow < 0.1 m (0.3ft) /h
- No filter / test

Additional information

The device adjusts the signal evaluation filters and the damping of the output signal to the typical rate of level change defined in this parameter:

For "Operating mode" = "Level" and "Medium type" = "Liquid"

Process property	Step response time / s
Very fast > 10 m (400 in)/min	5
Fast > 1 m (40 in)/min	5
Standard < 1 m (40in) /min	14
Medium < 10 cm (4in) /min	39
Slow < 1 cm (0.4in) /min	76
No filter / test	< 1

For "Operating mode" = "Level" and "Medium type" = "Solid"

Process property	Step response time / s
Very fast > 100 m (333 ft) /h	37
Fast > 10 m (33 ft) /h	37
Standard < 10 m (33 ft) /h	74
Medium < 1 m (3ft) /h	146
Slow < 0.1 m (0.3ft) /h	290
No filter / test	< 1

For "Operating mode" = "Interface" or "Interface with capacitance"

Process property	Step response time / s
Very fast > 10 m (400 in)/min	5
Fast > 1 m (40 in)/min	5
Standard < 1 m (40in) /min	23
Medium < 10 cm (4in) /min	47
Slow < 1 cm (0.4in) /min	81
No filter / test	2.2

Advanced process conditions



Navigation

Setup → Advanced setup → Level → Adv. conditions

Description

Specify additional process conditions (if required).

Selection

- None
- Oil/Water condensate
- Probe near tank bottom
- Build up
- Foam (>5cm/0,16ft)

Additional information

Meaning of the options

- **Oil/Water condensate** (only **Medium type = Liquid**)
Makes sure that in the case of two-phase media only the total level is detected (example: oil/condensate application).
- **Probe near tank bottom** (only for **Medium type = Liquid**)
Improves the empty detection, especially if the probe is mounted close to the tank bottom.
- **Build up**
Increases **EOP range upper area** in order to ensure a safe empty-detection even if the end-of-probe signal has shifted due to build-up.
Enables a safe empty-detection even if the end-of-probe signal has shifted due to build-up.
- **Foam (>5cm/0,16ft)** (only for **Medium type = Liquid**)
Optimizes the signal evaluation in applications with foam formation.

Level unit



Navigation Setup → Advanced setup → Level → Level unit

Description Select level unit.

Selection

<i>SI units</i>	<i>US units</i>
<ul style="list-style-type: none"> ■ % ■ m ■ mm 	<ul style="list-style-type: none"> ■ ft ■ in

Additional information The level unit may differ from the distance unit defined in the **Distance unit** parameter (→ 106):

- The unit defined in the **Distance unit** parameter is used for the basic calibration (**Empty calibration** (→ 108) and **Full calibration** (→ 108)).
- The unit defined in the **Level unit** parameter is used to display the (nonlinearized) level.

Blocking distance



Navigation Setup → Advanced setup → Level → Blocking dist.

Description Specify upper blocking distance UB.

User entry 0 to 200 m

Factory setting For rod and rope probes up to 8 m (26 ft): 200 mm (8 in)

Additional information Signals in the upper blocking distance are only evaluated if they have been outside the blocking distance when the device was switched on and move into the blocking distance due to a level change during operation. Signals which are already in the blocking distance when the device is switched on, are ignored.

- This behavior is only valid if the following two conditions are met:
 - Expert → Sensor → Echo tracking → Evaluation mode = **Short time history** or **Long time history**)
 - Expert → Sensor → Gas phase compensation → GPC mode= **On, Without correction** or **External correction**

If one of these conditions is not met, signals in the blocking distance will always be ignored.

- A different behavior for signals in the blocking distance can be defined in the **Blocking distance evaluation mode** parameter.

- If required, a different behavior for signals in the blocking distance can be defined by the Endress+Hauser service.

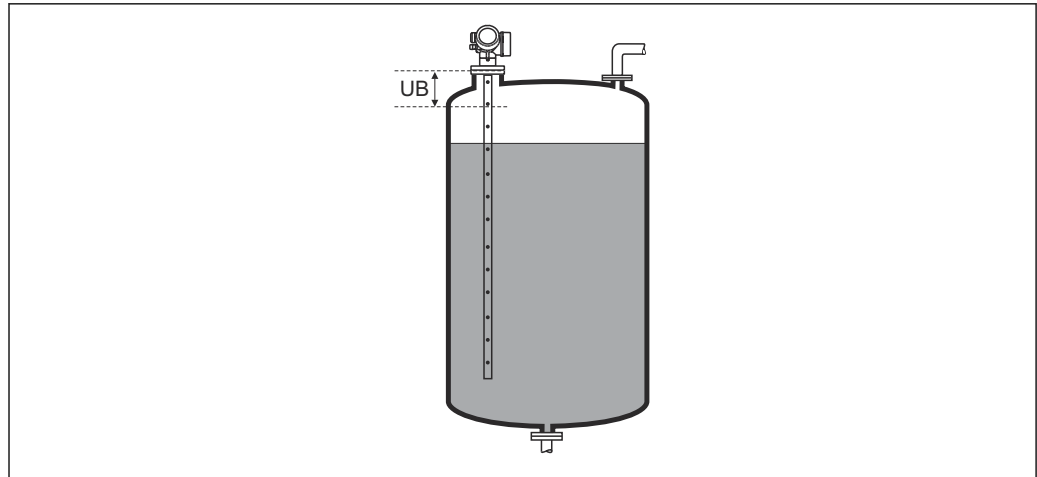

A0013219

45 Blocking distance (UB) for liquid measurements

Level correction



Navigation

Setup → Advanced setup → Level → Level correction

Description

Specify level correction (if required).

User entry

-200 000.0 to 200 000.0 %

Additional information

The value specified in this parameter is added to the measured level (before linearization).

"Linearization" submenu

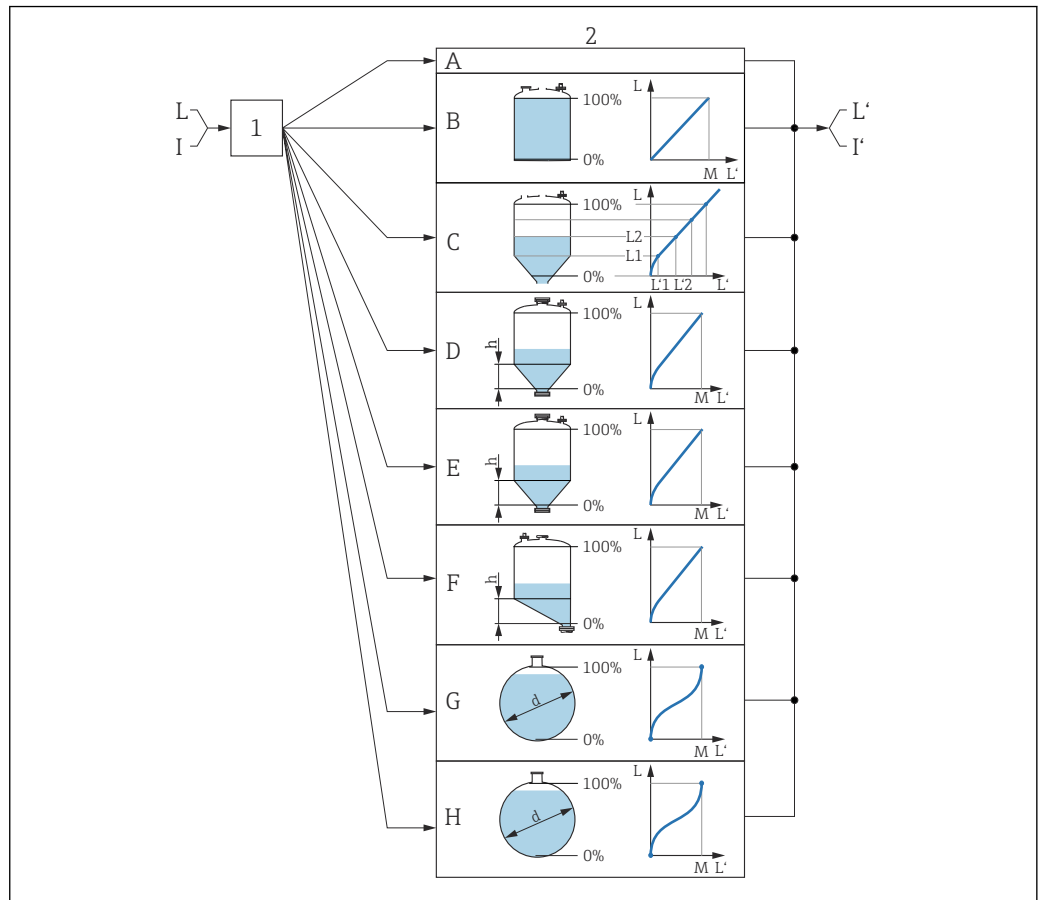

A0016084

46 Linearization: Conversion of the level and, if applicable, interface into a volume or a weight; the conversion depends on the vessel shape

- 1 Selection of linearization type and unit
- 2 Configuration of the linearization
- A Linearization type (→ 124) = None
- B Linearization type (→ 124) = Linear
- C Linearization type (→ 124) = Table
- D Linearization type (→ 124) = Pyramid bottom
- E Linearization type (→ 124) = Conical bottom
- F Linearization type (→ 124) = Angled bottom
- G Linearization type (→ 124) = Horizontal cylinder
- H Linearization type (→ 124) = Sphere
- I For "Operating mode" = "Interface" or "Interface with capacitance": interface before linearization (measured in the level unit)
- I' For "Operating mode" = "Interface" or "Interface with capacitance": interface after linearization (corresponds to volume or weight)
- L Level before linearization (measured in level unit)
- L' Level linearized (→ 127) (corresponds to volume or weight)
- M Maximum value (→ 127)
- d Diameter (→ 127)
- h Intermediate height (→ 128)

Structure of the submenu on the local display

Navigation  Setup → Advanced setup → Linearization

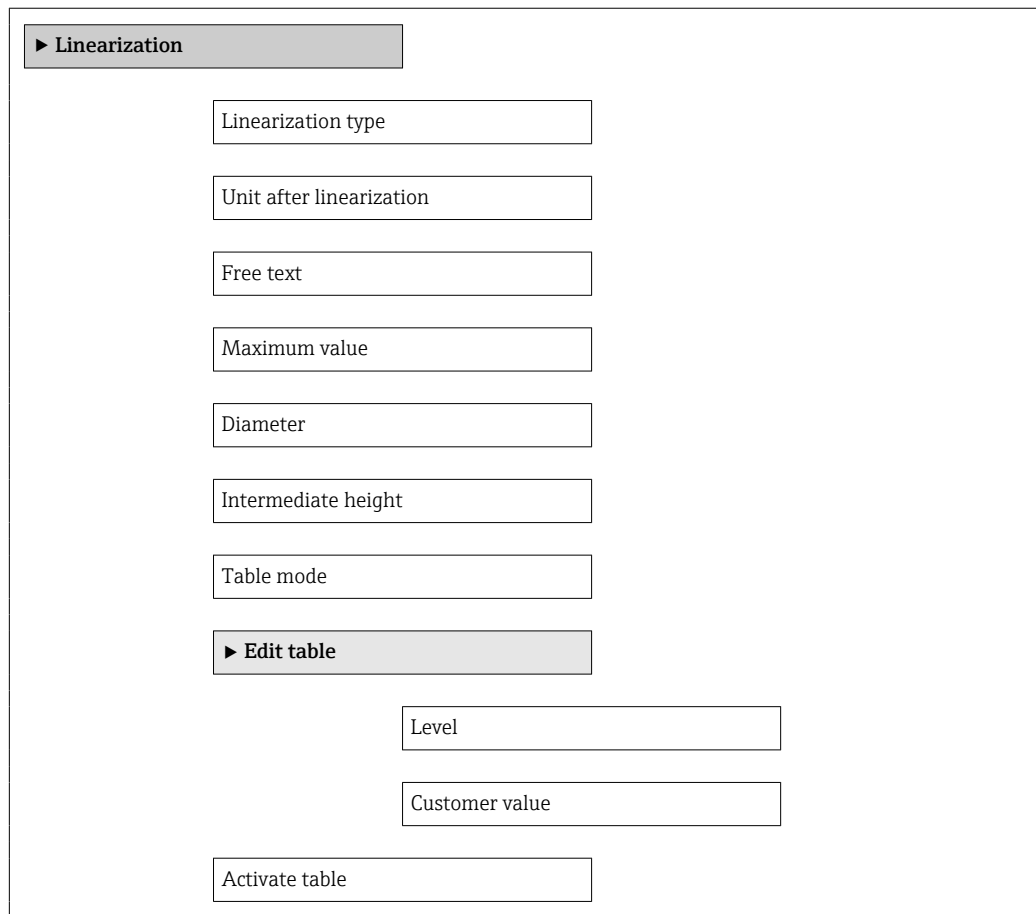

► Linearization

Linearization type

Unit after linearization

Free text

Maximum value

Diameter

Intermediate height

Table mode

► Edit table

Level

Customer value

Activate table

Structure of the submenu in the operating tool (e.g. FieldCare)

Navigation  Setup → Advanced setup → Linearization

► **Linearization**

Linearization type

Unit after linearization

Free text

Level linearized

Maximum value

Diameter

Intermediate height

Table mode

Table number

Level

Level

Customer value

Activate table

Description of the parameters

Navigation  Setup → Advanced setup → Linearization

Linearization type 

Navigation  Setup → Advanced setup → Linearization → Lineariz. type

Description Select linearization type.

- Selection**
- None
 - Linear
 - Table
 - Pyramid bottom
 - Conical bottom
 - Angled bottom
 - Horizontal cylinder
 - Sphere

Additional information

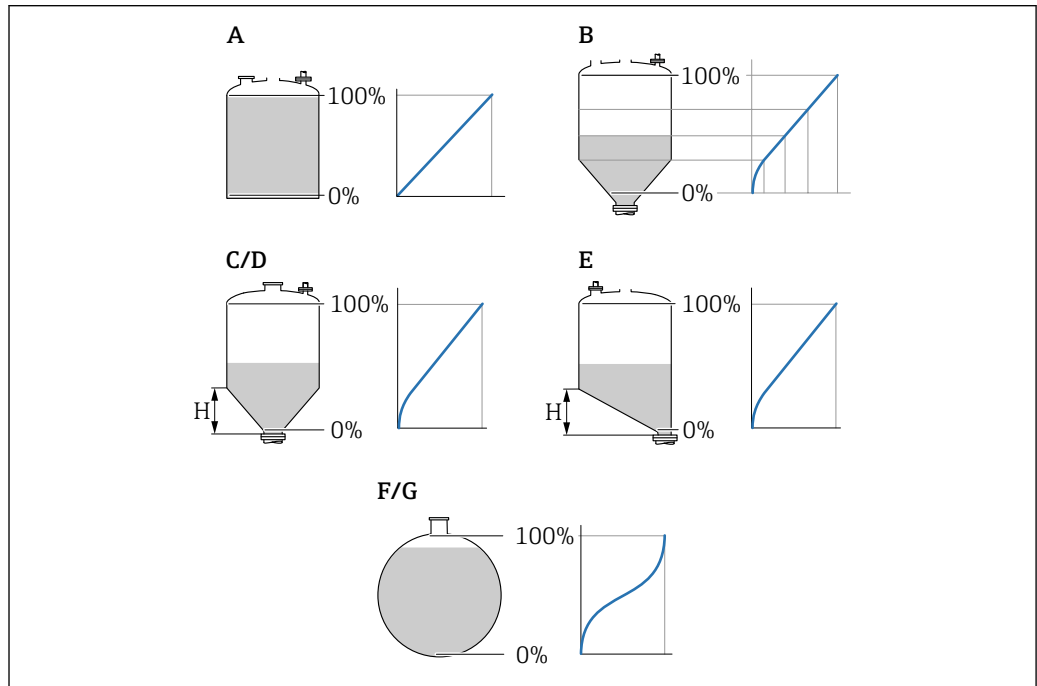

A0021476

 47 Linearization types

- A None
- B Table
- C Pyramid bottom
- D Conical bottom
- E Angled bottom
- F Sphere
- G Horizontal cylinder



Meaning of the options

■ None

The level is output in the level unit without being converted (linearized) beforehand.





■ Linear

The output value (volume/weight) is proportional to the level L. This applies, for example, to vertical cylindrical tanks and silos. The following parameters must also be specified:

- **Unit after linearization** (→  125)
- **Maximum value** (→  127): maximum volume or weight



■ Table

The relationship between the measured level L and the output value (volume/weight) is defined by a linearization table consisting of up to 32 pairs of values "level - volume" or "level - weight" respectively. The following parameters must also be specified:

- **Unit after linearization** (→  125)
- **Table mode** (→  128)
- For every point in the table: **Level** (→  129)
- For every point in the table: **Customer value** (→  130)
- **Activate table** (→  130)



■ Pyramid bottom

The output value corresponds to the volume or weight in a silo with a pyramid bottom. The following parameters must also be specified:

- **Unit after linearization** (→  125)
- **Maximum value** (→  127): maximum volume or weight
- **Intermediate height** (→  128): the height of the pyramid



■ Conical bottom

The output value corresponds to the volume or weight in a tank with a conical bottom. The following parameters must also be specified:

- **Unit after linearization** (→  125)
- **Maximum value** (→  127): maximum volume or weight
- **Intermediate height** (→  128): the height of the cone



■ Angled bottom

The output value corresponds to the volume or weight in a silo with an angled bottom. The following parameters must also be specified:

- **Unit after linearization** (→  125)
- **Maximum value** (→  127): maximum volume or weight
- **Intermediate height** (→  128): height of the angled bottom



■ Horizontal cylinder

The output value corresponds to the volume or weight in a horizontal cylinder. The following parameters must also be specified:

- **Unit after linearization** (→  125)
- **Maximum value** (→  127): maximum volume or weight
- **Diameter** (→  127)

■ Sphere



The output value corresponds to the volume or weight in a spherical tank. The following parameters must also be specified:

- **Unit after linearization** (→  125)
- **Maximum value** (→  127): maximum volume or weight
- **Diameter** (→  127)

Unit after linearization





Navigation



  Setup → Advanced setup → Linearization → Unit lineariz.

Prerequisite

Linearization type (→  124) ≠ None

Description	Select the unit for the linearized value.
Selection	<p>Selection/input (uint16)</p> <ul style="list-style-type: none"> ▪ 1095 = [short Ton] ▪ 1094 = [lb] ▪ 1088 = [kg] ▪ 1092 = [Ton] ▪ 1048 = [US Gal.] ▪ 1049 = [Imp. Gal.] ▪ 1043 = [ft³] ▪ 1571 = [cm³] ▪ 1035 = [dm³] ▪ 1034 = [m³] ▪ 1038 = [l] ▪ 1041 = [hl] ▪ 1342 = [%] ▪ 1010 = [m] ▪ 1012 = [mm] ▪ 1018 = [ft] ▪ 1019 = [inch] ▪ 1351 = [l/s] ▪ 1352 = [l/min] ▪ 1353 = [l/h] ▪ 1347 = [m³/s] ▪ 1348 = [m³/min] ▪ 1349 = [m³/h] ▪ 1356 = [ft³/s] ▪ 1357 = [ft³/min] ▪ 1358 = [ft³/h] ▪ 1362 = [US Gal./s] ▪ 1363 = [US Gal./min] ▪ 1364 = [US Gal./h] ▪ 1367 = [Imp. Gal./s] ▪ 1358 = [Imp. Gal./min] ▪ 1359 = [Imp. Gal./h] ▪ 32815 = [Ml/s] ▪ 32816 = [Ml/min] ▪ 32817 = [Ml/h] ▪ 1355 = [Ml/d]
Additional information	<p>The selected unit is only used for display purposes. The measured value is not converted on the basis of the selected unit.</p> <p> Distance-to-distance linearization is also possible, i.e. a linearization from the level unit to another length unit. Select the Linear linearization mode for this purpose. To specify the new level unit, select the Free text option in the Unit after linearization parameter and enter the unit in the Free text parameter (→  126).</p>

Free text

Navigation   Setup → Advanced setup → Linearization → Free text

Prerequisite **Unit after linearization** (→  125) = **Free text**

Description Enter unit symbol.

User entry Up to 32 alphanumerical characters (letters, numbers, special characters)

Level linearized

Navigation  Setup → Advanced setup → Linearization → Level linearized

Description Displays linearized level.

Additional information  This unit is defined by the **Unit after linearization** parameter.

Maximum value

Navigation   Setup → Advanced setup → Linearization → Maximum value



Prerequisite **Linearization type** (→  124) has one of the following values:

- Linear
- Pyramid bottom
- Conical bottom
- Angled bottom
- Horizontal cylinder
- Sphere

Description Linearized value corresponding to a level of 100%.

User entry -50 000.0 to 50 000.0 %

Diameter

Navigation   Setup → Advanced setup → Linearization → Diameter

Prerequisite **Linearization type** (→  124) has one of the following values:

- Horizontal cylinder
- Sphere

Description Diameter of the cylindrical or spherical tank.

User entry 0 to 9 999.999 m

Additional information The unit is defined in the **Distance unit** parameter (→  106).

Intermediate height



Navigation

Setup → Advanced setup → Linearization → Intermed. height

Prerequisite

Linearization type (→ 124) has one of the following values:

- Pyramid bottom
- Conical bottom
- Angled bottom

Description

Height of the pyramid, conical or angled bottom.

User entry

0 to 200 m

Additional information

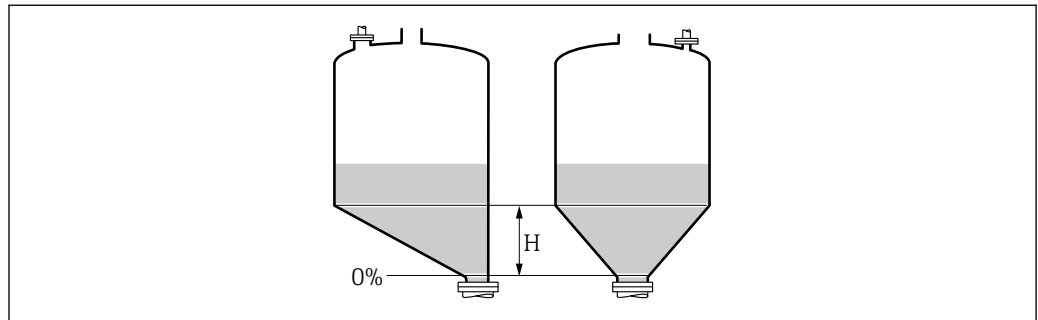

A0013264

H Intermediate height

The unit is defined in the **Distance unit** parameter (→ 106).

Table mode



Navigation

Setup → Advanced setup → Linearization → Table mode

Prerequisite

Linearization type (→ 124) = Table

Description

Select editing mode of the linearization table.

Selection

- Manual
- Semiautomatic
- Clear table
- Sort table



Additional information

Meaning of the options

- **Manual**
The level and the associated linearized value are entered manually for each linearization point.
- **Semiautomatic**
The level is measured by the device for each linearization point. The associated linearized value is entered manually.
- **Clear table**
Deletes the existing linearization table.
- **Sort table**
Rearranges the linearization points into an ascending order.



Conditions the linearization table must meet:



- The table may consist of up to 32 pairs of values "Level - Linearized Value".
- The table must be monotonic (monotonically increasing or decreasing).
- The first linearization point must refer to the minimum level.
- The last linearization point must refer to the maximum level.

 Before entering a linearization table, the values for **Empty calibration** (→  108) and **Full calibration** (→  108) must be set correctly.

If values of the table need to be changed after the full or empty calibration have been changed, a correct evaluation is only ensured if the existing table is deleted and the complete table is entered again. To do so delete the existing table (**Table mode** (→  128) = **Clear table**). Then enter a new table.

How to enter the table

- Via FieldCare
The table points can be entered via the **Table number** (→  129), **Level** (→  129) and **Customer value** (→  130) parameters. As an alternative, the graphic table editor may be used: Device Operation → Device Functions → Additional Functions → Linearization (Online/Offline)
- Via local display
Select the **Edit table** submenu to call up the graphic table editor. The table is displayed and can be edited line by line.

 The factory setting for the level unit is "%". If you want to enter the linearization table in physical units, you must select the appropriate unit in the **Level unit** parameter (→  119) beforehand.











 If a decreasing table is entered, the values for 20 mA and 4 mA of the current output are interchanged. That means: 20 mA refers to the lowest level, whereas 4 mA refers to the highest level.

Table number	
Navigation	 Setup → Advanced setup → Linearization → Table number
Prerequisite	Linearization type (→  124) = Table
Description	Select table point you are going to enter or change.
User entry	1 to 32



Level (Manual)	
Navigation	 Setup → Advanced setup → Linearization → Level
Prerequisite	<ul style="list-style-type: none"> ▪ Linearization type (→  124) = Table ▪ Table mode (→  128) = Manual
Description	Enter level value of the table point (value before linearization).
User entry	Signed floating-point number

Level (Semiautomatic)

Navigation	 Setup → Advanced setup → Linearization → Level
Prerequisite	<ul style="list-style-type: none"> ▪ Linearization type (→  124) = Table ▪ Table mode (→  128) = Semiautomatic
Description	Displays measured level (value before linearization). This value is transmitted to the table.





Customer value



Navigation	 Setup → Advanced setup → Linearization → Customer value
Prerequisite	Linearization type (→  124) = Table
Description	Enter linearized value for the table point.
User entry	Signed floating-point number

Activate table



Navigation	  Setup → Advanced setup → Linearization → Activate table
Prerequisite	Linearization type (→  124) = Table
Description	Activate (enable) or deactivate (disable) the linearization table.
Selection	<ul style="list-style-type: none"> ▪ Disable ▪ Enable
Additional information	<p>Meaning of the options</p> <ul style="list-style-type: none"> ▪ Disable The measured level is not linearized. If Linearization type (→  124) = Table at the same time, the device issues error message F435. ▪ Enable The measured level is linearized according to the table. <p> When editing the table, the Activate table parameter is automatically reset to Disable and must be reset to Enable after the table has been entered.</p>

"Safety settings" submenu

Navigation  Setup → Advanced setup → Safety sett.

Output echo lost 

Navigation  Setup → Advanced setup → Safety sett. → Output echo lost



Description Output signal in case of a lost echo.

Selection

- Last valid value
- Ramp at echo lost
- Value echo lost
- Alarm

Additional information

Meaning of the options

- **Last valid value**
The last valid value is kept in the case of a lost echo.
- **Ramp at echo lost**³⁾
In the case of a lost echo the output value is continuously shifted towards 0% or 100%. The slope of the ramp is defined in the **Ramp at echo lost** parameter (→  132).
- **Value echo lost**³⁾
In the case of a lost echo the output assumes the value defined in the **Value echo lost** parameter (→  131).
- **Alarm**
In the case of a lost echo the device generates an alarm; see the **Failure mode** parameter (→  142)

Value echo lost 



Navigation  Setup → Advanced setup → Safety sett. → Value echo lost

Prerequisite **Output echo lost** (→  131) = **Value echo lost**

Description Output value in case of a lost echo

User entry 0 to 200 000.0 %

Additional information Use the unit which has been defined for the measured value output:

- without linearization: **Level unit** (→  119)
- with linearization: **Unit after linearization** (→  125)

3) Only visible if "Linearization type" (→  124) = "None"

Ramp at echo lost



Navigation Setup → Advanced setup → Safety sett. → Ramp echo lost

Prerequisite **Output echo lost (→ 131) = Ramp at echo lost**

Description Slope of the ramp in the case of a lost echo

User entry Signed floating-point number

Additional information

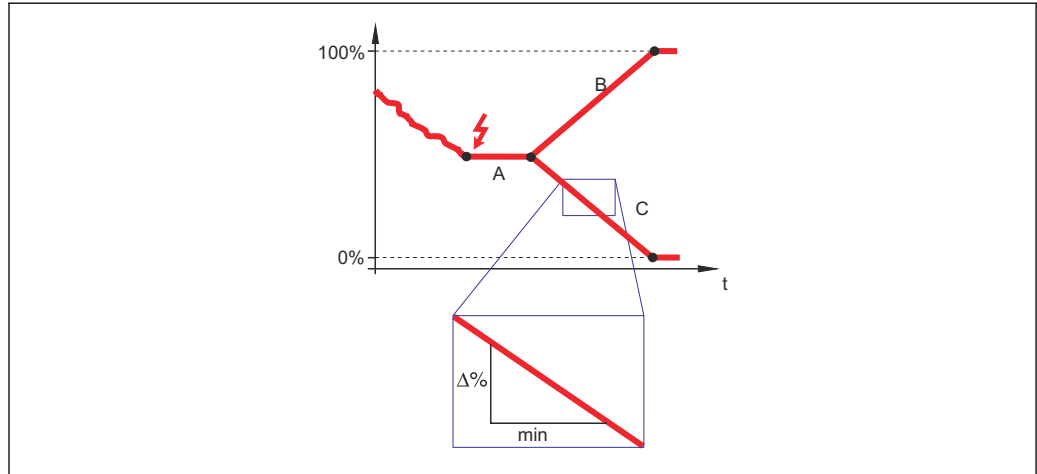

A0013269

- A Delay time echo lost
- B Ramp at echo lost (→ 132) (positive value)
- C Ramp at echo lost (→ 132) (negative value)

- The unit for the slope of the ramp is "percentage of the measuring range per minute" (%/min).
- For a negative slope of the ramp: The measured value is continuously decreased until it reaches 0%.
- For a positive slope of the ramp: The measured value is continuously increased until it reaches 100%.

Blocking distance



Navigation Setup → Advanced setup → Safety sett. → Blocking dist.

Description Specify upper blocking distance UB.

User entry 0 to 200 m

Factory setting For rod and rope probes up to 8 m (26 ft): 200 mm (8 in)

Additional information Signals in the upper blocking distance are only evaluated if they have been outside the blocking distance when the device was switched on and move into the blocking distance

due to a level change during operation. Signals which are already in the blocking distance when the device is switched on, are ignored.

- i** This behavior is only valid if the following two conditions are met:
- Expert → Sensor → Echo tracking → Evaluation mode = **Short time history** or **Long time history**)
 - Expert → Sensor → Gas phase compensation → GPC mode= **On, Without correction** or **External correction**

If one of these conditions is not met, signals in the blocking distance will always be ignored.

- i** A different behavior for signals in the blocking distance can be defined in the **Blocking distance evaluation mode** parameter.

- i** If required, a different behavior for signals in the blocking distance can be defined by the Endress+Hauser service.

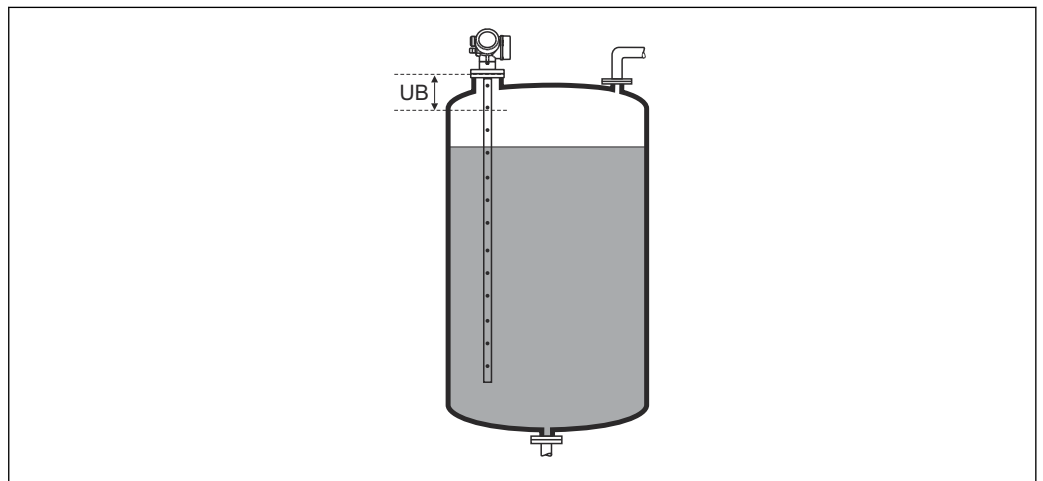

A0013219

48 Blocking distance (UB) for liquid measurements



"SIL/WHG confirmation" wizard

 The **SIL/WHG confirmation** wizard is only available for devices with SIL or WHG approval (Feature 590: "Additional Approval", option LA: "SIL" or LC: "WHG overflow prevention") which are currently **not** in the SIL- or WHG-locked state.

The **SIL/WHG confirmation** wizard is required to lock the device according to SIL or WHG. For details refer to the "Functional Safety Manual" of the respective device, which describes the locking procedure and the parameters of the sequence.

Navigation  Setup → Advanced setup → SIL/WHG confirm.

"Deactivate SIL/WHG" wizard

 The **Deactivate SIL/WHG** wizard (→  135) is only visible if the device is SIL-locked or WHG-locked. For details refer to the "Functional Safety Manual" of the respective device.

Navigation   Setup → Advanced setup → Deactiv. SIL/WHG

Reset write protection**Navigation**

  Setup → Advanced setup → Deactiv. SIL/WHG → Res. write prot.



Description

Enter unlocking code.

User entry

0 to 65 535

Code incorrect**Navigation**

  Setup → Advanced setup → Deactiv. SIL/WHG → Code incorrect

Description







Indicates that a wrong unlocking code has been entered. Select procedure.



Selection

- Reenter code
- Abort sequence



"Probe settings" submenu

The **Probe settings** submenu helps to ensure that the device correctly assigns the end of probe signal within the envelope curve. The assignment is correct if the length of probe indicated by the device matches the actual length of the probe. The automatic probe length correction can only be performed if the probe is installed in the vessel and is completely uncovered (no medium) over the entire length. For partially filled vessels and if the probe length is known, select **Confirm probe length** (→  137) = **Manual input** to enter the value manually.



-  If a mapping has been recorded after shortening the probe, it is no longer possible to perform an automatic probe length correction. There are two options if this occurs:
 - First delete the mapping curve using the **Record map** parameter (→  112) and the probe length correction can then be performed. After the probe length correction, a new mapping curve can be recorded using the **Record map** parameter (→  112).
 - Alternatively, select **Confirm probe length** (→  137) = **Manual input** and manually enter the probe length in the **Present probe length** parameter.
-  An automatic probe length correction is only possible after the correct option has been selected in the **Probe grounded** parameter (→  136).

Navigation   Setup → Advanced setup → Probe settings

Probe grounded 

- Navigation**   Setup → Advanced setup → Probe settings → Probe grounded
- Prerequisite** **Operating mode = Level**
- Description** Specify whether the probe is grounded.
- Selection**
 - No
 - Yes

Present probe length 

- Navigation**  Setup → Advanced setup → Probe settings → Pres. length
- Description**
 - In most cases:
Displays the length of the probe according to the currently measured end-of-probe signal.
 - For **Confirm probe length** (→  137) = **Manual input**:
Enter actual length of probe.
- User entry** 0 to 200 m

Confirm probe length
**Navigation**

Setup → Advanced setup → Probe settings → Confirm length

Description

Specify whether the value displayed in the **Present probe length** parameter matches the actual length of the probe. Based on this input, the device performs a probe length correction.

Selection

- Probe length OK
- Probe length too small
- Probe length too big
- Probe covered
- Manual input
- Probe length unknown

Additional information**Meaning of the options**

- **Probe length OK**

To be selected if the correct probe length is displayed. A correction is not required. The device exits the sequence.

- **Probe length too small**

To be selected if the displayed length is less than the actual probe length. A different end of probe signal is allocated and the newly calculated length is displayed in the **Present probe length** parameter. This procedure has to be repeated until the displayed value matches the actual length of the probe.

- **Probe length too big**

To be selected if the displayed length is greater than the actual probe length. A different end of probe signal is allocated and the newly calculated length is displayed in the **Present probe length** parameter. This procedure has to be repeated until the displayed value matches the actual length of the probe.

- **Probe covered**

To be selected if the probe is (partially or completely) covered. A probe length correction is impossible in this case.

- **Manual input**



To be selected if no automatic probe length correction is to be performed. Instead, the actual length of the probe must be entered manually in the **Present probe length** parameter. ⁴⁾

- **Probe length unknown**

To be selected if the actual probe length is unknown. A probe length correction is impossible in this case.

4) When operating via FieldCare, the **Manual input** option does not need to be selected explicitly; manual editing of the probe length is always possible here.

"Probe length correction" wizard

 The **Probe length correction** wizard is only available when operating via the local display. When operating via an operating tool, the parameters for probe length correction are located directly in the **Probe settings** submenu (→  136).

Navigation  Setup → Advanced setup → Probe settings → Prob.length corr

Confirm probe length **Navigation**

 Setup → Advanced setup → Probe settings → Prob.length corr → Confirm length

Description

Specify whether the value displayed in the **Present probe length** parameter matches the actual length of the probe. Based on this input, the device performs a probe length correction.

Selection

- Probe length OK
- Probe length too small
- Probe length too big
- Probe covered
- Manual input
- Probe length unknown

Additional information**Meaning of the options**

- **Probe length OK**
To be selected if the correct probe length is displayed. A correction is not required. The device exits the sequence.
- **Probe length too small**
To be selected if the displayed length is less than the actual probe length. A different end of probe signal is allocated and the newly calculated length is displayed in the **Present probe length** parameter. This procedure has to be repeated until the displayed value matches the actual length of the probe.
- **Probe length too big**
To be selected if the displayed length is greater than the actual probe length. A different end of probe signal is allocated and the newly calculated length is displayed in the **Present probe length** parameter. This procedure has to be repeated until the displayed value matches the actual length of the probe.
- **Probe covered**
To be selected if the probe is (partially or completely) covered. A probe length correction is impossible in this case.
- **Manual input**
To be selected if no automatic probe length correction is to be performed. Instead, the actual length of the probe must be entered manually in the **Present probe length** parameter.⁵⁾
- **Probe length unknown**
To be selected if the actual probe length is unknown. A probe length correction is impossible in this case.

5) When operating via FieldCare, the **Manual input** option does not need to be selected explicitly; manual editing of the probe length is always possible here.

Present probe length

**Navigation**

Setup → Advanced setup → Probe settings → Prob.length corr → Pres. length



Description

- In most cases:
Displays the length of the probe according to the currently measured end-of-probe signal.
- For **Confirm probe length** (→ 137) = **Manual input**:
Enter actual length of probe.

User entry

0 to 200 m

"Current output 1 to 2" submenu

 The **Current output 2** submenu (→  140) is only available for devices with two current outputs.

Navigation  Setup → Advanced setup → Curr.output 1 to 2

Assign current output 1 to 2 

Navigation

 Setup → Advanced setup → Curr.output 1 to 2 → Assign curr.

Description

Select process variable for current output.

Selection

- Level linearized
- Distance
- Electronic temperature
- Relative echo amplitude
- Analog output adv. diagnostics 1
- Analog output adv. diagnostics 2

Factory setting



For level measurements

- Current output 1: Level linearized
- Current output 2 ⁶⁾: Level linearized

Additional information

Definition of the current range for the process variables

Process variable	4 mA value	20 mA value
Level linearized	0 % ¹⁾ or the associated linearized value	100 % ²⁾ or the associated linearized value
Distance	0 (i.e. level is at the reference point)	Empty calibration (→  108) (i.e. level is at 0 %)
Electronic temperature	-50 °C (-58 °F)	100 °C (212 °F)
Relative echo amplitude	0 mV	2 000 mV
Analog output adv. diagnostics 1/2	depending on the parametrization of the Advanced Diagnostics	

- 1) the 0% level is defined by **Empty calibration** parameter (→  108)
- 2) The 100% level is defined by **Full calibration** parameter (→  108)

 It may be necessary to adjust the 4mA and 20mA values to the application (especially in the case of the **Analog output adv. diagnostics 1/2** option).

This can be done by the following parameters:

- Expert → Output → Current output 1 to 2 → Turn down
- Expert → Output → Current output 1 to 2 → 4 mA value
- Expert → Output → Current output 1 to 2 → 20 mA value

6) only for devices with two current outputs

Current span



Navigation Setup → Advanced setup → Curr.output 1 to 2 → Current span

Description Determines the current range used to transmit the measured value.
 '4...20mA':
 Measured variable: 4 ...20 mA
 '4...20mA NAMUR':
 Measured variable: 3.8 ... 20.5 mA
 '4...20mA US':
 Measured variable: 3.9 ... 20.8 mA
 'Fixed current':
 Measured variable transmitted via HART only
 Note:
 Currents below 3.6 mA or above 21.95 mA can be used to signal an alarm.

- Selection**
- 4...20 mA
 - 4...20 mA NAMUR
 - 4...20 mA US
 - Fixed current

Additional information *Meaning of the options*

Option	Current range for process variable	Lower alarm signal level	Upper alarm signal level
4...20 mA	4 to 20.5 mA	< 3.6 mA	> 21.95 mA
4...20 mA NAMUR	3.8 to 20.5 mA	< 3.6 mA	> 21.95 mA
4...20 mA US	3.9 to 20.8 mA	< 3.6 mA	> 21.95 mA
Fixed current	Constant current, defined in the Fixed current parameter (→ 141).		

- In the case of an error, the output current assumes the value defined in the **Failure mode** parameter (→ 142).
 - If the measured value is out of the measuring range, **Current output** diagnostic message is issued.
- In a HART multidrop loop only one device can use the analog current to transmit a signal. For all other devices one must set:
 - **Current span** = **Fixed current**
 - **Fixed current** (→ 141) = **4 mA**

Fixed current



Navigation Setup → Advanced setup → Curr.output 1 to 2 → Fixed current

Prerequisite **Current span** (→ 141) = **Fixed current**

Description Define constant value of the output current.





User entry 4 to 22.5 mA

Damping output





Navigation	Setup → Advanced setup → Curr.output 1 to 2 → Damping out.
Description	Reaction time of the output signal on fluctuation in the measured value.
User entry	0.0 to 999.9 s
Additional information	Fluctuations of the measured value affect the output current with an exponential delay, the time constant τ of which is defined in this parameter. With a small time constant the output reacts immediately to changes of the measured value. With a big time constant the reaction of the output is more delayed. For $\tau = 0$ (factory setting) there is no damping.

Failure mode



Navigation	Setup → Advanced setup → Curr.output 1 to 2 → Failure mode
Prerequisite	Current span (→ 141) ≠ Fixed current
Description	<p>Defines which current the output assumes in the case of an error.</p> <p>'Min.': < 3.6mA</p> <p>'Max.': > 21.95mA</p> <p>'Last valid value': Last valid value before occurrence of the error.</p> <p>'Actual value': Output current is equal to the measured value; error is ignored.</p> <p>'Defined value': User defined value.</p>
Selection	<ul style="list-style-type: none"> ▪ Min. ▪ Max. ▪ Last valid value ▪ Actual value ▪ Defined value

Additional information	<p>Meaning of the options</p> <ul style="list-style-type: none"> ▪ Min. The current output adopts the value of the lower alarm level according to the Current span parameter (→  141). ▪ Max. The current output adopts the value of the upper alarm level according to the Current span parameter (→  141). ▪ Last valid value The current remains constant at the last value it had before the error occurred. ▪ Actual value The output current follows the actual measured value; the error is ignored. ▪ Defined value The output current assumes the value defined in the Failure current parameter (→  143). <p> The error behavior of other output channels is not influenced by these settings but is defined in separate parameters.</p>
-------------------------------	--



Failure current

Navigation	  Setup → Advanced setup → Curr.output 1 to 2 → Failure current
Prerequisite	Failure mode (→  142) = Defined value
Description	Defines which current the output assumes in case of an error.
User entry	3.59 to 22.5 mA

Output current 1 to 2

Navigation	  Setup → Advanced setup → Curr.output 1 to 2 → Output curr. 1 to 2
Description	Shows the actual calculated value of the output current.

"Switch output" submenu

 The **Switch output** submenu (→  144) is only available for devices with a switch output.⁷⁾

Navigation  Setup → Advanced setup → Switch output

Switch output function**Navigation**

 Setup → Advanced setup → Switch output → Switch out funct

Description

Defines the function of the switch output.

'Off'

The switch output is always open (non-conductive)

'On'

The switch output is always closed (conductive).

'Diagnostic behavior'

The switch output is normally closed and is only opened if a diagnostic event is present.

'Limit'

The switch output is normally closed and is only opened if a measured variable exceeds a defined limit.

'Digital output'

The switch output is controlled by one of the digital output blocks of the device.

Selection

- Off
- On
- Diagnostic behavior
- Limit
- Digital Output

Additional information**Meaning of the options**

- **Off**

The output is always open (non-conductive).

- **On**

The output is always closed (conductive).

- **Diagnostic behavior**

The output is normally closed and is only opened if a diagnostic event is present. The **Assign diagnostic behavior** parameter (→  145) determines for which type of event the output is opened.

- **Limit**

The output is normally closed and is only opened if a measured variable exceeds or falls below a defined limit. The limit values are defined by the following parameters:

- **Assign limit** (→  145)

- **Switch-on value** (→  146)

- **Switch-off value** (→  147)

- **Digital Output**

The switching state of the output tracks the output value of a DI function block. The function block is selected in the **Assign status** parameter (→  145).

 The **Off** and **On** options can be used to simulate the switch output.

7) Order code 020 "Power supply; output", option B, E or G

Assign status



Navigation	Setup → Advanced setup → Switch output → Assign status
Prerequisite	Switch output function (→ 144) = Digital Output
Description	Assigns a Discrete Output Block or an Advanced Diagnostic Block to the switch output.
Selection	<ul style="list-style-type: none"> ■ Off ■ Digital output AD 1 ■ Digital output AD 2
Additional information	The Digital output AD 1 and Digital output AD 2 options refer to the Advanced Diagnostics Blocks. A switch signal generated in these blocks can be output via the switch output.

Assign limit



Navigation	Setup → Advanced setup → Switch output → Assign limit
Prerequisite	Switch output function (→ 144) = Limit
Description	Defines which process variable will be checked for limit violation.
Selection	<ul style="list-style-type: none"> ■ Off ■ Level linearized ■ Distance ■ Interface linearized * ■ Interface distance * ■ Thickness upper layer * ■ Terminal voltage ■ Electronic temperature ■ Measured capacitance * ■ Relative echo amplitude ■ Relative interface amplitude * ■ Absolute echo amplitude ■ Absolute interface amplitude *

Assign diagnostic behavior



Navigation	Setup → Advanced setup → Switch output → Assign diag. beh
Prerequisite	Switch output function (→ 144) = Diagnostic behavior
Description	Defines to which behavior of diagnostic events the switch output reacts.

* Visibility depends on order options or device settings

Selection

- Alarm
- Alarm or warning
- Warning

Switch-on value



Navigation

Setup → Advanced setup → Switch output → Switch-on value

Prerequisite

Switch output function (→ 144) = Limit

Description

Defines the switch-on point.
The output is closed if the assigned process variable rises above this point.

User entry

Signed floating-point number

Additional information

The switching behavior depends on the relative position of the **Switch-on value** and **Switch-off value** parameters:

Switch-on value > Switch-off value

- The output is closed if the measured value is larger than **Switch-on value**.
- The output is opened if the measured value is smaller than **Switch-off value**.

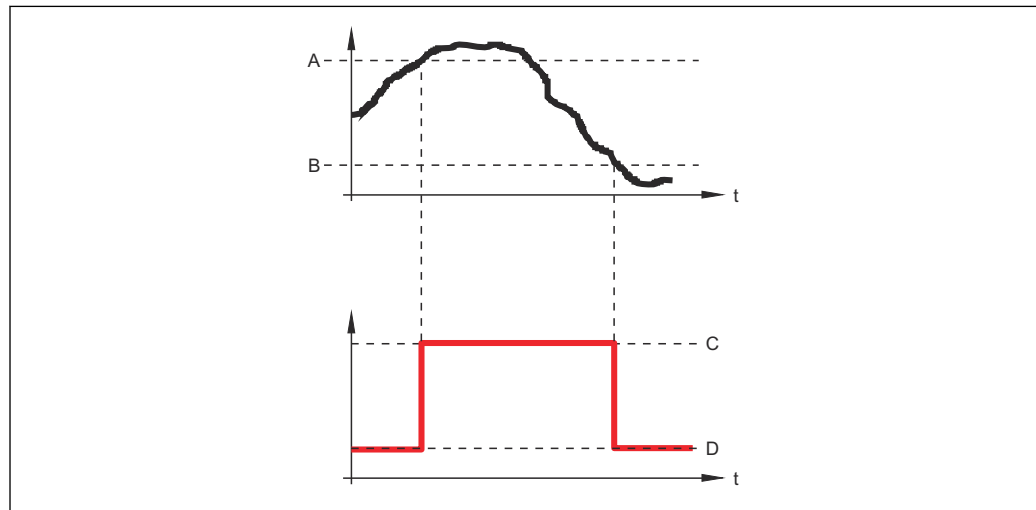

A0015585

- A Switch-on value
 B Switch-off value
 C Output closed (conductive)
 D Output opened (non-conductive)

Switch-on value < Switch-off value

- The output is closed if the measured value is smaller than **Switch-on value**.
- The output is opened if the measured value is larger than **Switch-off value**.

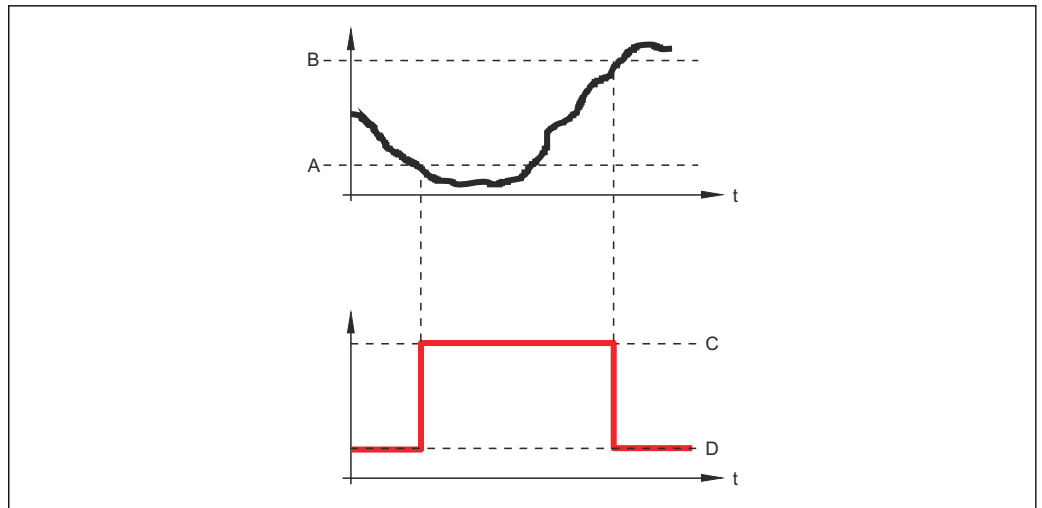

A0015586

- A Switch-on value
- B Switch-off value
- C Output closed (conductive)
- D Output opened (non-conductive)

Switch-on delay



Navigation Setup → Advanced setup → Switch output → Switch-on delay

Prerequisite **▪ Switch output function (→ 144) = Limit**
▪ Assign limit (→ 145) ≠ Off

Description Defines the delay applied before the output is switched on.

User entry 0.0 to 100.0 s

Switch-off value



Navigation Setup → Advanced setup → Switch output → Switch-off value

Prerequisite **Switch output function (→ 144) = Limit**





Description Defines the switch-off point.
 The output is opened if the assigned process variable falls below this point.

User entry Signed floating-point number

Additional information The switching behavior depends on the relative position of the **Switch-on value** and **Switch-off value** parameters; description: see the **Switch-on value** parameter (→ 146).



Switch-off delay



Navigation	  Setup → Advanced setup → Switch output → Switch-off delay
Prerequisite	<ul style="list-style-type: none"> ▪ Switch output function (→  144) = Limit ▪ Assign limit (→  145) ≠ Off
Description	Defines the delay applied before the output is switched off.
User entry	0.0 to 100.0 s



Failure mode



Navigation	  Setup → Advanced setup → Switch output → Failure mode
Prerequisite	Switch output function (→  144) = Limit or Digital Output
Description	Defines the state of the switch output in case of an error.
Selection	<ul style="list-style-type: none"> ▪ Actual status ▪ Open ▪ Closed



Additional information

Switch status

Navigation	  Setup → Advanced setup → Switch output → Switch status
Description	Current status of the switch output.

Invert output signal



Navigation	  Setup → Advanced setup → Switch output → Invert outp.sig.
Description	<p>'No' The switch output behaves as per its parameter setting.</p> <p>'Yes' The switching behavior is inverted as compared to its parameter setting.</p>
Selection	<ul style="list-style-type: none"> ▪ No ▪ Yes

Additional information**Meaning of the options**

- **No**
The behavior of the switch output is as described above.
- **Yes**
The states **Open** and **Closed** are inverted as compared to the description above.

"Display" submenu

 **Display** submenu is only visible if a display module is connected to the device.

Navigation  Setup → Advanced setup → Display

Language**Navigation**

 Setup → Advanced setup → Display → Language

Description

Set display language.

Selection

- English
- Deutsch *
- Français *
- Español *
- Italiano *
- Nederlands *
- Portuguesa *
- Polski *
- русский язык (Russian) *
- Svenska *
- Türkçe *
- 中文 (Chinese) *
- 日本語 (Japanese) *
- 한국어 (Korean) *
- Bahasa Indonesia *
- tiếng Việt (Vietnamese) *
- čeština (Czech) *

Factory setting

The language selected in feature 500 of the product structure.
If no language has been selected: **English**

Additional information**Format display****Navigation**

 Setup → Advanced setup → Display → Format display

Description

Select how measured values are shown on the display.

Selection

- 1 value, max. size
- 1 bargraph + 1 value
- 2 values
- 1 value large + 2 values
- 4 values

* Visibility depends on order options or device settings

Additional information

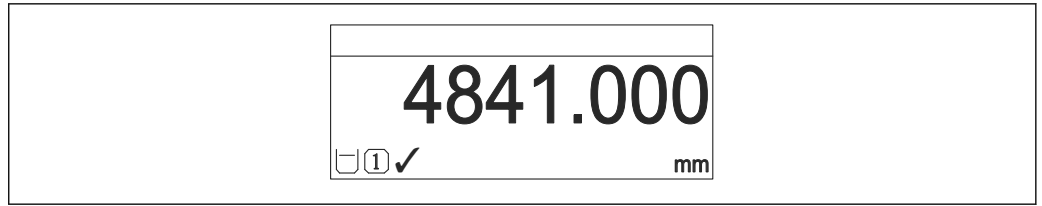

A0019963

49 "Format display" = "1 value, max. size"

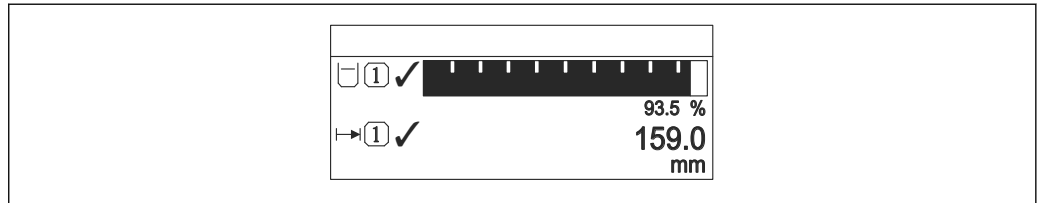

A0019964

50 "Format display" = "1 bargraph + 1 value"

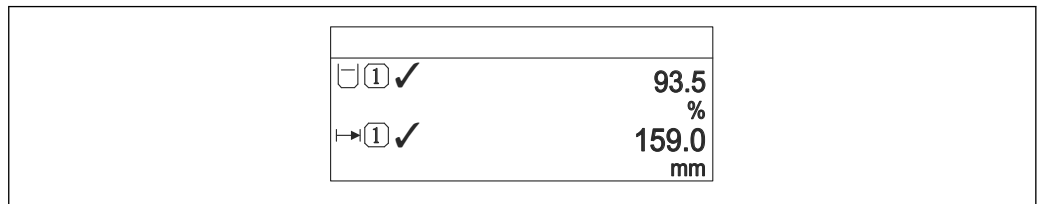

A0019965

51 "Format display" = "2 values"

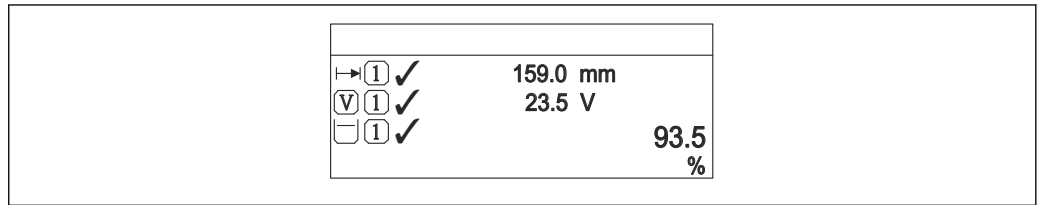

A0019966

52 "Format display" = "1 value large + 2 values"

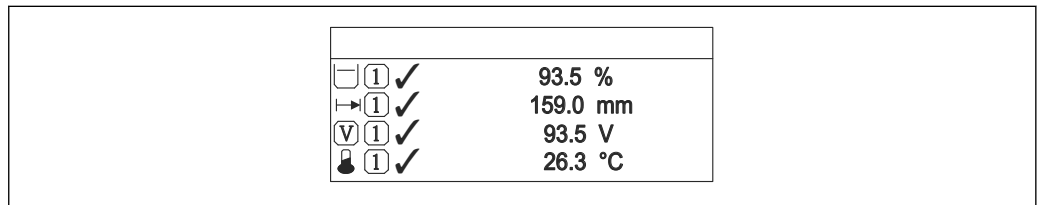

A0019968

53 "Format display" = "4 values"

- i

 ■ The **Value 1 to 4 display** parameters are used to specify which measured values are shown on the local display and in what order.
- If more measured values are specified than the display mode selected permits, then the values alternate on the device display. The display time until the next change is configured in the **Display interval** parameter (→ 152).

Value 1 to 4 display

Navigation Setup → Advanced setup → Display → Value 1 display

Description Select the measured value that is shown on the local display.

Selection

- Level linearized
- Distance
- Interface linearized *
- Interface distance *
- Thickness upper layer *
- Current output 1
- Measured current
- Current output 2 *
- Terminal voltage
- Electronic temperature
- Measured capacitance *
- Analog output adv. diagnostics 1
- Analog output adv. diagnostics 2

Factory setting

For level measurements

- Value 1 display: Level linearized
- Value 2 display: Distance
- Value 3 display: Current output 1
- Value 4 display: None

Decimal places 1 to 4

Navigation Setup → Advanced setup → Display → Decimal places 1

Description This selection does not affect the measurement and calculation accuracy of the device.

Selection

- x
- x.x
- x.xx
- x.xxx
- x.xxxx

Additional information The setting does not affect the measuring or computational accuracy of the device.

Display interval

Navigation Setup → Advanced setup → Display → Display interval

Description Set time measured values are shown on display if display alternates between values.

User entry 1 to 10 s

* Visibility depends on order options or device settings

Additional information This parameter is only relevant if the number of selected measuring values exceeds the number of values the selected display format can display simultaneously.

Display damping 🔒

Navigation 🏠📄 Setup → Advanced setup → Display → Display damping

Description Set display reaction time to fluctuations in the measured value.

User entry 0.0 to 999.9 s

Header 🔒

Navigation 🏠📄 Setup → Advanced setup → Display → Header

Description Select header contents on local display.

- Selection**
- Device tag
 - Free text

Additional information

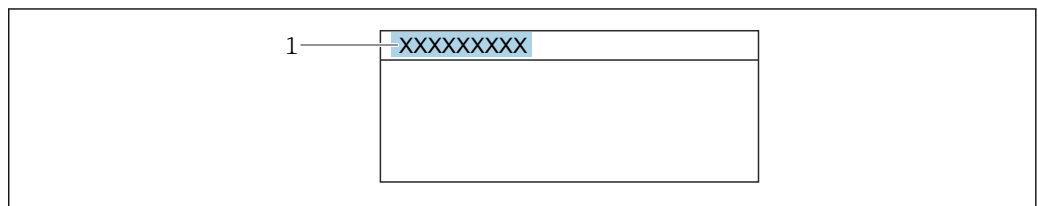

A0029422

1 Position of the header text on the display

Meaning of the options

- **Device tag**
Is defined in the **Device tag** parameter (→ 📄 106).
- **Free text**
Is defined in the **Header text** parameter (→ 📄 153).

Header text 🔒

Navigation 🏠📄 Setup → Advanced setup → Display → Header text



Prerequisite **Header** (→ 📄 153) = **Free text**

Description Enter display header text.

User entry Character string comprising numbers, letters and special characters (12)

Additional information The number of characters which can be displayed depends on the characters used.

Separator 



Navigation   Setup → Advanced setup → Display → Separator

Description Select decimal separator for displaying numerical values.

Selection

- .
- ,

Number format 

Navigation   Setup → Advanced setup → Display → Number format



Description Choose number format for the display.

Selection

- Decimal
- ft-in-1/16"

Additional information The **ft-in-1/16"** option is only valid for distance units.

Decimal places menu 

Navigation   Setup → Advanced setup → Display → Dec. places menu

Description Select number of decimal places for the representation of numbers within the operating menu.



Selection

- x
- x.x
- x.xx
- x.xxx
- x.xxxx

Additional information

- Is only valid for numbers in the operating menu (e.g. **Empty calibration, Full calibration**), but not for the measured value display. The number of decimal places for the measured value display is defined in the **Decimal places 1 to 4** parameters
- This setting does not affect the accuracy of the device for measuring or calculating the value

Backlight







Navigation   Setup → Advanced setup → Display → Backlight

Prerequisite The device has the SD03 local display (with optical keys).

Description Switch the local display backlight on and off.

Selection	<ul style="list-style-type: none">▪ Disable▪ Enable
Additional information	<p>Meaning of the options</p> <ul style="list-style-type: none">▪ Disable Switches the backlight off.▪ Enable Switches the backlight on. <p> Regardless of the setting in this parameter the backlight may be automatically switched off by the device if the supply voltage is too low.</p>

Contrast display

Navigation	 Setup → Advanced setup → Display → Contrast display
Description	Adjust local display contrast setting to ambient conditions (e.g. lighting or reading angle).
User entry	20 to 80 %
Factory setting	Dependent on the display.
Additional information	<p> Setting the contrast via push-buttons:</p> <ul style="list-style-type: none">▪ Darker: press the   buttons simultaneously.▪ Brighter: press the   buttons simultaneously.

"Configuration backup display" submenu

 This submenu is only visible if a display module is connected to the device.

The configuration of the device can be saved to the display module at a certain point of time (backup). The saved configuration can be restored to the device if required, e.g. in order to bring the device back into a defined state. The configuration can also be transferred to a different device of the same type using the display module.

Navigation  Setup → Advanced setup → Conf.backup disp

Operating time

Navigation  Setup → Advanced setup → Conf.backup disp → Operating time

Description Indicates how long the device has been in operation.

Additional information *Maximum time*
9999 d (≈ 27 years)

Last backup

Navigation  Setup → Advanced setup → Conf.backup disp → Last backup

Description Indicates when the last data backup was saved to the display module.

Configuration management

Navigation  Setup → Advanced setup → Conf.backup disp → Config. managem.



Description Select action for managing the device data in the display module.

Selection

- Cancel
- Execute backup
- Restore
- Duplicate
- Compare
- Clear backup data



Additional information

Meaning of the options

- **Cancel**
No action is executed and the user exits the parameter.
 - **Execute backup**
A backup copy of the current device configuration in the HistoROM (built-in in the device) is saved to the display module of the device.
 - **Restore**
The last backup copy of the device configuration is copied from the display module to the HistoROM of the device.
 - **Duplicate**
The transmitter configuration is duplicated to another device using the transmitter display module. The following parameters, which characterize the individual measuring point are **not** included in the transmitted configuration:
 - HART date code
 - HART short tag
 - HART message
 - HART descriptor
 - HART address
 - Device tag
 - Medium type
 - **Compare**
The device configuration saved in the display module is compared to the current device configuration of the HistoROM. The result of this comparison is displayed in the **Comparison result** parameter (→  157).
 - **Clear backup data**
The backup copy of the device configuration is deleted from the display module of the device.
-  While this action is in progress, the configuration cannot be edited via the local display and a message on the processing status appears on the display.
-  If an existing backup is restored to a different device using the **Restore** option, it may occur that some device functionalities are no longer available. In some cases even a device reset will not restore the original status.
- In order to transmit a configuration to a different device, the **Duplicate** option should always be used.

Backup state

Navigation



  Setup → Advanced setup → Conf.backup disp → Backup state

Description

Displays which backup action is currently in progress.

Comparison result

Navigation

  Setup → Advanced setup → Conf.backup disp → Compar. result

Description

Comparison between present device data and display backup.

Additional information**Meaning of the display options****■ Settings identical**

The current device configuration of the HistoROM is identical to the backup copy in the display module.

■ Settings not identical

The current device configuration of the HistoROM is not identical to the backup copy in the display module.

■ No backup available

There is no backup copy of the device configuration of the HistoROM in the display module.

■ Backup settings corrupt

The current device configuration of the HistoROM is corrupt or not compatible with the backup copy in the display module.

■ Check not done

The device configuration of the HistoROM has not yet been compared to the backup copy in the display module.

■ Dataset incompatible

The data sets are incompatible and can not be compared.





To start the comparison, set **Configuration management** (→  156) = **Compare**.













If the transmitter configuration has been duplicated from a different device by **Configuration management** (→  156) = **Duplicate**, the new device configuration in the HistoROM is only partially identical to the configuration stored in the display module: Sensor specific properties (e.g. the mapping curve) are not duplicated. Thus, the result of the comparison will be **Settings not identical**.



"Administration" submenu

Navigation  Setup → Advanced setup → Administration

Define access code 

Navigation	 Setup → Advanced setup → Administration → Def. access code
Description	Define release code for write access to parameters.
User entry	0 to 9999
Additional information	<p> If the factory setting is not changed or if "0" is entered, the parameters are not write-protected and the device configuration data can therefore always be modified. The user is logged on in the "Maintenance" role.</p> <p> The write protection affects all parameters marked with the  symbol in the document. On the local display, the  symbol in front of a parameter indicates that the parameter is write-protected.</p> <p> Once the access code has been defined, write-protected parameters can only be modified if the access code is entered in the Enter access code parameter (→  115).</p> <p> Please contact your Endress+Hauser Sales Center if you lose the access code.</p> <p> If operating via the local display: the new access code is only valid once it has been confirmed in the Confirm access code parameter (→  161).</p>

Device reset 

Navigation	  Setup → Advanced setup → Administration → Device reset
Description	Reset the device configuration - either entirely or in part - to a defined state.
Selection	<ul style="list-style-type: none"> ■ Cancel ■ To factory defaults ■ To delivery settings ■ Of customer settings ■ To transducer defaults ■ Restart device
Additional information	<p>Meaning of the options</p> <ul style="list-style-type: none"> ■ Cancel No action ■ To factory defaults All parameters are reset to the order-code specific factory setting. ■ To delivery settings All parameters are reset to the delivery setting. The delivery setting may differ from the factory default if customer specific settings have been ordered. This option is only visible if customer specific settings have been ordered.

- **Of customer settings**

All customer parameters are reset to their factory setting. Service parameters, however, remain unchanged.

- **To transducer defaults**

Every measurement-related parameter is reset to its factory setting. Service parameters and communication-related parameters, however, remain unchanged.

- **Restart device**

The restart resets every parameter which is stored in the volatile memory (RAM) to the factory setting (e.g. measured value data). The device configuration remains unchanged.

"Define access code" wizard

 The **Define access code** wizard is only available when operating via the local display. When operating via an operating tool, the **Define access code** parameter is located directly in the **Administration** submenu. The **Confirm access code** parameter is not available for operation via operating tool.

Navigation  Setup → Advanced setup → Administration → Def. access code

Define access code



Navigation

 Setup → Advanced setup → Administration → Def. access code → Def. access code

Description

→  159

Confirm access code



Navigation

 Setup → Advanced setup → Administration → Def. access code → Confirm code

Description

Confirm the entered access code.

User entry

0 to 9999

17.5 "Diagnostics" menu

Navigation  Diagnostics

Actual diagnostics



Navigation  Diagnostics → Actual diagnos.

Description Displays current diagnostic message.

Additional information The display consists of:

- Symbol for event behavior
- Code for diagnostic behavior
- Operating time of occurrence
- Event text

 If several messages are active at the same time, the messages with the highest priority is displayed.

 Information on what is causing the message, and remedy measures, can be viewed via the  symbol on the display.

Timestamp

Navigation  Diagnostics → Timestamp

Description Displays the timestamp for the currently active diagnostic message.



Previous diagnostics

Navigation  Diagnostics → Prev.diagnostics

Description Displays the last diagnostic message which has been active before the current message.

Additional information The display consists of:

- Symbol for event behavior
- Code for diagnostic behavior
- Operating time of occurrence
- Event text

 The condition displayed may still apply. Information on what is causing the message, and remedy measures, can be viewed via the  symbol on the display.

Timestamp

Navigation  Diagnostics → Timestamp

Description Shows the timestamp of the previous diagnostic message.

Operating time from restart

Navigation   Diagnostics → Time fr. restart

Description Displays the time the device has been in operation since the last device restart.

Operating time

Navigation   Diagnostics → Operating time

Description Indicates how long the device has been in operation.

Additional information *Maximum time*
9999 d (≈ 27 years)

17.5.1 "Diagnostic list" submenu

Navigation  Diagnostics → Diagnostic list

Diagnostics 1 to 5

Navigation

 Diagnostics → Diagnostic list → Diagnostics 1

Description

Display the current diagnostics messages with the highest to fifth-highest priority.

Additional information

The display consists of:

- Symbol for event behavior
- Code for diagnostic behavior
- Operating time of occurrence
- Event text

Timestamp 1 to 5

Navigation

 Diagnostics → Diagnostic list → Timestamp 1 to 5

Description

Timestamp of the diagnostic message.

17.5.2 "Event logbook" submenu

 The **Event logbook** submenu is only available when operating via the local display. When operating via FieldCare, the event list can be displayed in the FieldCare function "Event List / HistoROM".

Navigation  Diagnostics → Event logbook

Filter options

Navigation

 Diagnostics → Event logbook → Filter options

Description

Define which category of event messages is shown in the Events list submenu.

Selection

- All
- Failure (F)
- Function check (C)
- Out of specification (S)
- Maintenance required (M)
- Information (I)



Additional information



-  ▪ This parameter is only used for operation via the local display.
 ▪ The status signals are categorized according to NAMUR NE 107.

"Event list" submenu

The **Event list** submenu displays the history of past events of the category selected in the **Filter options** parameter (→  165). A maximum of 100 events are displayed in chronological order.

The following symbols indicate whether an event has occurred or has ended:

- : Event has occurred
- : Event has ended

 Information on what is causing the message, and remedy instructions, can be viewed via the -button.

Display format

- For event messages in category I: information event, event text, "recording event" symbol and time the event occurred
- For event messages in category F, M, C, S (status signal): diagnostics event, event text, "recording event" symbol and time the event occurred

Navigation  Diagnostics → Event logbook → Event list



17.5.3 "Device information" submenu

Navigation  Diagnostics → Device info



Device tag

Navigation	 Diagnostics → Device info → Device tag
Description	Enter the name for the measuring point.
User interface	Character string comprising numbers, letters and special characters

Serial number











Navigation	 Diagnostics → Device info → Serial number
Description	Shows the serial number of the measuring device.
Additional information	<p> Uses of the serial number</p> <ul style="list-style-type: none"> ▪ To identify the device quickly, e.g. when contacting Endress+Hauser. ▪ To obtain specific information on the device using the Device Viewer: www.endress.com/deviceviewer <p> The serial number is also indicated on the nameplate.</p>

Firmware version

Navigation	 Diagnostics → Device info → Firmware version
Description	Shows the device firmware version installed.
User interface	xx.yy.zz
Additional information	<p> For firmware versions differing only in the last two digits ("zz") there is no difference concerning functionality or operation.</p>

Device name

Navigation	 Diagnostics → Device info → Device name
Description	Shows the name of the transmitter.

Order code 	
Navigation	  Diagnostics → Device info → Order code
Description	Shows the device order code.
User interface	Character string comprising numbers, letters and special characters
Additional information	The order code is generated from the extended order code, which defines all device features of the product structure. In contrast, the device features can not be read directly from the order code.
Extended order code 1 to 3 	
Navigation	  Diagnostics → Device info → Ext. order cd. 1
Description	Display the three parts of the extended order code.
User interface	Character string comprising numbers, letters and special characters
Additional information	The extended order code indicates the version of all the features of the product structure and thus uniquely identifies the device.
Device revision	
Navigation	  Diagnostics → Device info → Device revision
Description	Shows the device revision with which the device is registered with the HART Communication Foundation.
Additional information	The device revision is used to allocate the correct Device Description file (DD) to the device.
Device ID	
Navigation	  Diagnostics → Device info → Device ID
Description	Shows the device ID for identifying the device in a HART network.
Additional information	In addition to the Device type and Manufacturer ID, the Device ID is part of the unique device identification (Unique ID) which characterizes each HART device unambiguously.

Device type

Navigation Diagnostics → Device info → Device type**Description**

Shows the device type with which the measuring device is registered with the HART Communication Foundation.

Additional information

Manufacturer ID

Navigation Diagnostics → Device info → Manufacturer ID**Description**

Use this function to view the manufacturer ID with which the measuring device is registered with the HART Communication Foundation.

User interface

2-digit hexadecimal number



Factory setting

0x11 (for Endress+Hauser)

17.5.4 "Measured values" submenu

Navigation   Diagnostics → Measured val.

Distance

Navigation   Diagnostics → Measured val. → Distance

Description Displays the measured distance D_L between the reference point (lower edge of the flange or threaded connection) and the level.

Additional information

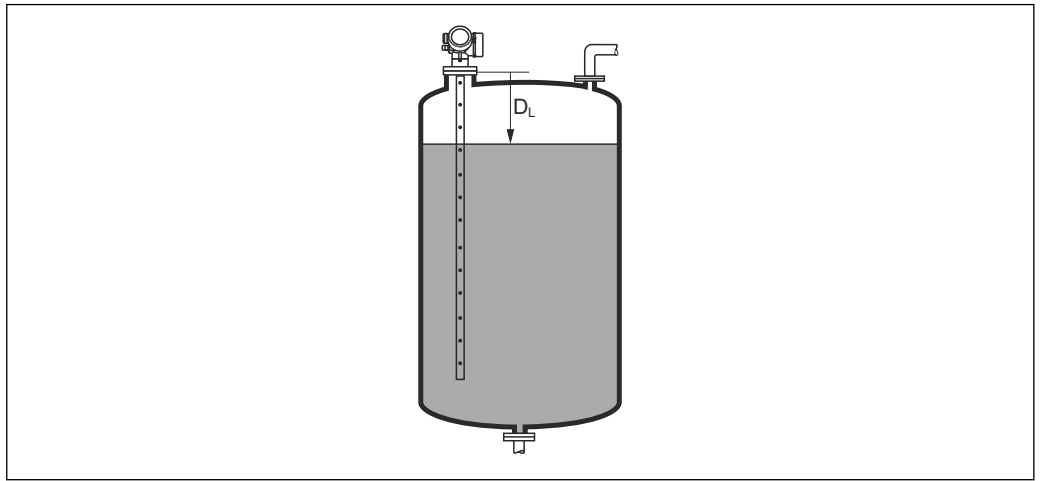



A0013198

 54 Distance for liquid measurements

 The unit is defined in the **Distance unit** parameter (→  106).



Level linearized

Navigation   Diagnostics → Measured val. → Level linearized

Description Displays linearized level.



Additional information  This unit is defined by the **Unit after linearization** parameter.

Output current 1 to 2



Navigation   Diagnostics → Measured val. → Output curr. 1 to 2

Description Shows the actual calculated value of the output current.

Measured current 1

Navigation	  Diagnostics → Measured val. → Measur. curr. 1
Prerequisite	Only available for current output 1
Description	Shows the current value of the current output which is currently measured.

Terminal voltage 1

Navigation	  Diagnostics → Measured val. → Terminal volt. 1
Description	Shows the current terminal voltage that is applied at the output.

17.5.5 "Data logging" submenu

Navigation  Diagnostics → Data logging

Assign channel 1 to 4

Navigation  Diagnostics → Data logging → Assign chan. 1 to 4

Description Assign a process variable to logging channel.

Selection

- Off
- Level linearized
- Distance
- Unfiltered distance
- Interface linearized *
- Interface distance *
- Unfiltered interface distance
- Thickness upper layer *
- Current output 1
- Measured current
- Current output 2 *
- Terminal voltage
- Electronic temperature
- Measured capacitance *
- Absolute echo amplitude
- Relative echo amplitude
- Absolute interface amplitude *
- Relative interface amplitude *
- Absolute EOP amplitude
- EOP shift
- Noise of signal
- Calculated DC value *
- Analog output adv. diagnostics 1
- Analog output adv. diagnostics 2

Additional information A total of 1000 measured values can be logged. This means:

- 1000 data points if 1 logging channel is used
- 500 data points if 2 logging channels are used
- 333 data points if 3 logging channels are used
- 250 data points if 4 logging channels are used

If the maximum number of data points is reached, the oldest data points in the data log are cyclically overwritten in such a way that the last 1000, 500, 333 or 250 measured values are always in the log (ring memory principle).

 The logged data are deleted if a new option is selected in this parameter.

* Visibility depends on order options or device settings

Logging interval
**Navigation**

- Diagnostics → Data logging → Logging interval
- Diagnostics → Data logging → Logging interval

Description

Define the logging interval t_{log} for data logging. This value defines the time interval between the individual data points in the memory.

User entry

1.0 to 3 600.0 s

Additional information

This parameter defines the interval between the individual data points in the data log, and thus the maximum loggable process time T_{log} :

- If 1 logging channel is used: $T_{log} = 1000 \cdot t_{log}$
- If 2 logging channels are used: $T_{log} = 500 \cdot t_{log}$
- If 3 logging channels are used: $T_{log} = 333 \cdot t_{log}$
- If 4 logging channels are used: $T_{log} = 250 \cdot t_{log}$

Once this time elapses, the oldest data points in the data log are cyclically overwritten such that a time of T_{log} always remains in the memory (ring memory principle).

The logged data are deleted if this parameter is changed.

*Example***When using 1 logging channel**

- $T_{log} = 1000 \cdot 1 \text{ s} = 1000 \text{ s} \approx 16.5 \text{ min}$
- $T_{log} = 1000 \cdot 10 \text{ s} = 10000 \text{ s} \approx 2.75 \text{ h}$
- $T_{log} = 1000 \cdot 80 \text{ s} = 80000 \text{ s} \approx 22 \text{ h}$
- $T_{log} = 1000 \cdot 3600 \text{ s} = 3600000 \text{ s} \approx 41 \text{ d}$

Clear logging data
**Navigation**

- Diagnostics → Data logging → Clear logging
- Diagnostics → Data logging → Clear logging

Description

Clear the entire logging data.

Selection

- Cancel
- Clear data

"Display channel 1 to 4" submenu

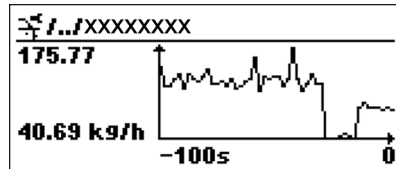

i The **Display channel 1 to 4** submenus are only available for operation via the local display. When operating via FieldCare, the logging diagram can be displayed in the FieldCare function "Event List / HistoROM" .

The **Display channel 1 to 4** submenus invoke a diagram of the logging history of the respective channel.



- x-axis: depending on the number of selected channels, 250 to 1000 measured values of a process variable are displayed.
- y-axis: covers the approximate measured value span and constantly adapts this to the measurement.









i To return to the operating menu, press \oplus and \ominus simultaneously.

Navigation   Diagnostics → Data logging → Displ.channel 1 to 4

17.5.6 "Simulation" submenu









The **Simulation** submenu is used to simulate specific measuring values or other conditions. This helps to check the correct configuration of the device and connected control units.

Conditions which can be simulated

Condition to be simulated	Associated parameters
Specific value of a process variable	<ul style="list-style-type: none"> ▪ Assign measurement variable (→  176) ▪ Process variable value (→  176)
Specific value of the output current	<ul style="list-style-type: none"> ▪ Current output simulation (→  176) ▪ Value current output (→  177)
Specific state of the switch output	<ul style="list-style-type: none"> ▪ Switch output simulation (→  177) ▪ Switch status (→  177)
Existence of an alarm	Device alarm simulation (→  178)
Existence of a specific diagnostic message	Diagnostic event simulation (→  178)

Structure of the submenu



Navigation  Expert → Diagnostics → Simulation

► Simulation	
Assign measurement variable	→  176
Process variable value	→  176
Current output 1 to 2 simulation	→  176
Value current output 1 to 2	→  177
Switch output simulation	→  177
Switch status	→  177
Device alarm simulation	→  178
Diagnostic event simulation	→  178



Description of parameters

Navigation  Expert → Diagnostics → Simulation

Assign measurement variable

Navigation	 Expert → Diagnostics → Simulation → Assign meas.var.
Description	Defines the process variable to be simulated.
Selection	<ul style="list-style-type: none"> ■ Off ■ Level ■ Interface * ■ Thickness upper layer * ■ Level linearized ■ Interface linearized ■ Thickness linearized
Additional information	<ul style="list-style-type: none"> ■ The value of the variable to be simulated is defined in the Process variable value parameter (→  176). ■ If Assign measurement variable ≠ Off, a simulation is active. This is indicated by a diagnostic message of the <i>Function check (C)</i> category.

Process variable value

Navigation	 Expert → Diagnostics → Simulation → Proc. var. value
Prerequisite	Assign measurement variable (→  176) ≠ Off
Description	Defines the value of the selected variable. The outputs assume values or states according to this value.
User entry	Signed floating-point number
Additional information	Downstream measured value processing and the signal output use this simulation value. In this way, users can verify whether the measuring device has been configured correctly.

Current output 1 to 2 simulation

Navigation	 Expert → Diagnostics → Simulation → Curr.out. 1 to 2 sim.
Description	Switch the simulation of the current output on and off.



* Visibility depends on order options or device settings

Selection

- Off
- On

Additional information An active simulation is indicated by a diagnostic message of the *Function check (C)* category.

Value current output 1 to 2

Navigation   Expert → Diagnostics → Simulation → Value curr.out 1 to 2

Prerequisite **Current output simulation (→  176) = On**

Description Defines the value of the simulated output current.

User entry 3.59 to 22.5 mA

Additional information The current output assumes the value specified in this parameter. In this way, users can verify the correct adjustment of the current output and the correct function of connected control units.

Switch output simulation



Navigation   Expert → Diagnostics → Simulation → Switch sim.

Description Switch the simulation of the switch output on and off.

Selection

- Off
- On

Switch status

Navigation   Expert → Diagnostics → Simulation → Switch status

Prerequisite **Switch output simulation (→  177) = On**

Description Current status of the switch output.

Selection

- Open
- Closed

Additional information The switch status assumes the value defined in this parameter. This helps to check correct operation of connected control units.

Device alarm simulation

**Navigation**

Expert → Diagnostics → Simulation → Dev. alarm sim.

Description

Switch the device alarm on and off.

Selection

- Off
- On

Additional information

When selecting the **On** option, the device generates an alarm. This helps to check the correct output behavior of the device in the case of an alarm.

An active simulation is indicated by the **C484 Failure mode simulation** diagnostic message.

Diagnostic event simulation

**Navigation**

Expert → Diagnostics → Simulation → Diag. event sim.

Description

Select the diagnostic event to be simulated.

Note:

To terminate the simulation, select 'Off'.

Additional information

When operated via the local display, the selection list can be filtered according to the event categories (**Diagnostic event category** parameter).

17.5.7 "Device check" submenu

Navigation  Diagnostics → Device check

Start device check

Navigation	 Diagnostics → Device check → Start dev. check
Description	Start a device check.
Selection	<ul style="list-style-type: none"> ■ No ■ Yes
Additional information	In the case of a lost echo a device check can not be performed.



Result device check

Navigation	 Diagnostics → Device check → Result dev.check
Description	Displays the result of the device check.
Additional information	<p>Meaning of the display options</p> <ul style="list-style-type: none"> ■ Installation ok Measurement possible without restrictions. ■ Accuracy reduced A measurement is possible. However, the measuring accuracy may be reduced due to the signal amplitudes. ■ Measurement capability reduced A measurement is currently possible. However, there is the risk of an echo loss. Check the mounting position of the device and the dielectric constant of the medium. ■ Check not done No device check has been performed.



Last check time

Navigation	 Diagnostics → Device check → Last check time
Description	Displays the operating time at which the last device check has been performed.
User interface	Character string comprising numbers, letters and special characters

Level signal

Navigation	  Diagnostics → Device check → Level signal
Prerequisite	Device check has been performed.
Description	Displays result of the device check for the level signal.
User interface	<ul style="list-style-type: none">▪ Check not done▪ Check not OK▪ Check OK
Additional information	For Level signal = Check not OK : Check the mounting position of the device and the dielectric constant of the medium.

Launch signal

Navigation	  Diagnostics → Device check → Launch signal
Prerequisite	Device check has been performed.
Description	Displays result of the display check for the launch signal.
User interface	<ul style="list-style-type: none">▪ Check not done▪ Check not OK▪ Check OK
Additional information	For Launch signal = Check not OK : Check the mounting position of the device. In non-metallic vessels use a metal plate or a metal flange.

17.5.8 "Heartbeat" submenu

 The **Heartbeat** submenu is only available via **FieldCare** or **DeviceCare**. It contains the wizards which are part of the **Heartbeat Verification** and **Heartbeat Monitoring** application packages.

Detailed description

SD01872F

Navigation  Diagnostics → Heartbeat

Index

A

Access authorization to parameters	
Read access	42
Write access	42
Access code	42
Incorrect input	42
Access status display (Parameter)	115
Access status tooling (Parameter)	114
Accessories	
Communication-specific	85
Device-specific	79
Service-specific	86
System components	86
Activate table (Parameter)	130
Actual diagnostics (Parameter)	162
Administration (Submenu)	159
Advanced process conditions (Parameter)	118
Advanced setup (Submenu)	114
Application	9
Assign channel 1 to 4 (Parameter)	171
Assign current output (Parameter)	140
Assign diagnostic behavior (Parameter)	145
Assign limit (Parameter)	145
Assign measurement variable (Parameter)	176
Assign status (Parameter)	145

B

Backlight (Parameter)	154
Backup state (Parameter)	157
Blocking distance (Parameter)	119, 132
Bluetooth® wireless technology	41, 55

C

Cleaning	75
Clear logging data (Parameter)	172
Code incorrect (Parameter)	135
Comparison result (Parameter)	157
Configuration backup display (Submenu)	156
Configuration management (Parameter)	156
Configuration of a level measurement	59
Configuring level measurement	59
Configuring the operating language	58
Confirm access code (Parameter)	161
Confirm distance (Parameter)	111, 113
Confirm probe length (Parameter)	137, 138
Context menu	52
Contrast display (Parameter)	155
Current output 1 to 2 (Submenu)	140
Current output 1 to 2 simulation (Parameter)	176
Current span (Parameter)	141
Customer value (Parameter)	130

D

Damping output (Parameter)	142
Data logging (Submenu)	171
Deactivate SIL/WHG (Wizard)	135

Decimal places 1 (Parameter)	152
Decimal places menu (Parameter)	154
Define access code (Parameter)	159, 161
Define access code (Wizard)	161
Defining the access code	43
Device alarm simulation (Parameter)	178
Device check (Submenu)	179
Device description files	54
Device ID (Parameter)	167
Device information (Submenu)	166
Device name (Parameter)	166
Device replacement	77
Device reset (Parameter)	159
Device revision (Parameter)	167
Device tag (Parameter)	106, 166
Device type (Parameter)	168
Diagnostic event	66
In the operating tool	67
Diagnostic event simulation (Parameter)	178
Diagnostic events	65
Diagnostic list	69
Diagnostic list (Submenu)	164
Diagnostic message	65
Diagnostics	
Symbols	65
Diagnostics (Menu)	162
Diagnostics 1 (Parameter)	164
Diameter (Parameter)	127
DIP switch	
see Write protection switch	
Display (Submenu)	150
Display and operating module FHX50	39
Display channel 1 to 4 (Submenu)	173
Display damping (Parameter)	153
Display interval (Parameter)	152
Display module	47
Display symbols	48
Disposal	78
Distance (Parameter)	109, 113, 169
Distance unit (Parameter)	106
Document	
Function	5
Document function	5

E

Electronics housing	
Design	13
Empty calibration (Parameter)	108
Enter access code (Parameter)	115
Envelope curve display	53
Event history	72
Event level	
Explanation	66
Symbols	66
Event list	72
Event list (Submenu)	165

Event logbook (Submenu) 165
 Event text 66
 Extended order code 1 (Parameter) 167
 Exterior cleaning 75

F

Failure current (Parameter) 143
 Failure mode (Parameter) 142, 148
 FHX50 39
 Field of application
 Residual risks 9
 Filter options (Parameter) 165
 Filtering the event logbook 72
 Firmware version (Parameter) 166
 Fixed current (Parameter) 141
 Format display (Parameter) 150
 Free text (Parameter) 126
 Full calibration (Parameter) 108
 FV (HART variable) 54

H

Hardware write protection 44
 HART protocol 40
 HART variables 54
 Header (Parameter) 153
 Header text (Parameter) 153
 Heartbeat (Submenu) 181
 Housing
 Design 13
 Turning 25

I

Input mask 50
 Intended use 9
 Intermediate height (Parameter) 128
 Invert output signal (Parameter) 148

K

Keypad lock
 Disabling 46
 Enabling 46

L

Language (Parameter) 150
 Last backup (Parameter) 156
 Last check time (Parameter) 179
 Launch signal (Parameter) 180
 Level (Parameter) 109, 129, 130
 Level (Submenu) 116
 Level correction (Parameter) 120
 Level linearized (Parameter) 127, 169
 Level signal (Parameter) 180
 Level unit (Parameter) 119
 Linearization (Submenu) 122, 123, 124
 Linearization type (Parameter) 124
 Local display
 see Diagnostic message
 see In alarm condition
 Locking status 48
 Locking status (Parameter) 114

Logging interval (Parameter) 172

M

Maintenance 75
 Managing the device configuration 61
 Manufacturer ID (Parameter) 168
 Mapping (Wizard) 113
 Mapping end point (Parameter) 112, 113
 Maximum value (Parameter) 127
 Measured current 1 (Parameter) 170
 Measured value symbols 49
 Measured values (Submenu) 169
 Media 9
 Medium group (Parameter) 107
 Medium property (Parameter) 116
 Medium type (Parameter) 116
 Menu
 Diagnostics 162
 Setup 106
 Mounting outside the vessel 21
 Mounting position for level measurements 17

N

Non-metal vessels 21
 Number format (Parameter) 154

O

Onsite operation 39
 Operating elements
 Diagnostic message 66
 Operating module 47
 Operating time (Parameter) 156, 163
 Operating time from restart (Parameter) 163
 Operational safety 10
 Order code (Parameter) 167
 Output current 1 to 2 (Parameter) 143, 169
 Output echo lost (Parameter) 131
 Overvoltage protection
 General information 35

P

Present mapping (Parameter) 112
 Present probe length (Parameter) 136, 139
 Previous diagnostics (Parameter) 162
 Probe grounded (Parameter) 136
 Probe length correction (Wizard) 138
 Probe settings (Submenu) 136
 Process property (Parameter) 117
 Process variable value (Parameter) 176
 Product security 10
 PV (HART variable) 54

R

Ramp at echo lost (Parameter) 132
 Read access 42
 Record map (Parameter) 112, 113
 Registered trademarks 8
 Remedial measures
 Calling up 67
 Closing 67

Repair concept	77
Replacing a device	77
Requirements for personnel	9
Reset write protection (Parameter)	135
Result device check (Parameter)	179
Return	78
Rod probe	
Design	12
Rod probes	
Lateral loading capacity	19
S	
Safety instructions	
Basic	9
Safety settings (Submenu)	131
Separator (Parameter)	154
Serial number (Parameter)	166
Service interface (CDI)	40
Settings	
Managing the device configuration	61
Operating language	58
Setup (Menu)	106
Signal quality (Parameter)	110
SIL/WHG confirmation (Wizard)	134
Simulation (Submenu)	175, 176
Spare parts	78
Nameplate	78
Start device check (Parameter)	179
Status signals	48, 65
Submenu	
Administration	159
Advanced setup	114
Configuration backup display	156
Current output 1 to 2	140
Data logging	171
Device check	179
Device information	166
Diagnostic list	164
Display	150
Display channel 1 to 4	173
Event list	72, 165
Event logbook	165
Heartbeat	181
Level	116
Linearization	122, 123, 124
Measured values	169
Probe settings	136
Safety settings	131
Simulation	175, 176
Switch output	144
SV (HART variable)	54
Switch output (Submenu)	144
Switch output function (Parameter)	144
Switch output simulation (Parameter)	177
Switch status (Parameter)	148, 177
Switch-off delay (Parameter)	148
Switch-off value (Parameter)	147
Switch-on delay (Parameter)	147
Switch-on value (Parameter)	146

Symbols	
For correction	50
In the text and numeric editor	50
System components	86
System integration	54

T

Table mode (Parameter)	128
Table number (Parameter)	129
Tank type (Parameter)	106
Terminal voltage 1 (Parameter)	170
Thermal insulation	23
Timestamp (Parameter)	162, 163
Timestamp 1 to 5 (Parameter)	164
Tool	24
Transmitter	
Turning the display	26
Turning the display module	26
Transmitter housing	
Turning	25
Troubleshooting	63
Tube diameter (Parameter)	107
Turning the display	26
Turning the display module	26
TV (HART variable)	54

U

Unit after linearization (Parameter)	125
Use of measuring instrument	
see Intended use	
Use of the measuring instruments	
Borderline cases	9
Incorrect use	9

V

Value 1 display (Parameter)	152
Value current output 1 to 2 (Parameter)	177
Value echo lost (Parameter)	131

W

Wizard	
Deactivate SIL/WHG	135
Define access code	161
Mapping	113
Probe length correction	138
SIL/WHG confirmation	134
Workplace safety	10
Write access	42
Write protection	
Via access code	43
Via write protection switch	44
Write protection switch	44



71664102

www.addresses.endress.com
