

Technical Information

Solicap M

FTI55

Capacitance

Point level switch for bulk solids



Application

For applications with very high lateral loads up to 300 Nm (221 lbf ft). Fieldgate and Solicap represent a solution for material provisioning and logistical optimization (inventory control)

- Process connections: flanges and threads
- International explosion protection certificates, SIL

Benefits

- Highest safety and reliability due to robust design for demanding process conditions
- Cost savings thanks to easy and fast commissioning as calibration is performed at the press of a button
- Universal application thanks to wide range of certificates and approvals
- Two-stage overvoltage protection against static discharges from the silo
- Active build-up compensation for bulk solids with caking tendency (under development)
- Increased safety due to permanent automatic monitoring of electronics
- Reduction in storage costs thanks to easy-to-shorten rod model (for partial insulation)

Table of contents

Document information	3	Mechanical construction	22
Document conventions	3	Housing	22
Function and system design	4	Housing heights with adapter	24
Measuring principle	4	Process connections and flanges	24
Function	5	Rod probes FTI55	25
Application examples	5	Materials	28
Measuring system	5	Weight	29
Electronic inserts	8	Operability	29
System integration via Fieldgate	9	2-wire AC electronic insert FEI51	29
Input	9	DC PNP electronic insert FEI52	30
Measured variable	9	3-wire electronic insert FEI53	32
Measuring range	9	AC and DC with relay output electronic insert FEI54	33
Input signal	9	SIL2 / SIL3 electronic insert FEI55	34
Measuring conditions	9	PFM electronic insert FEI57S	36
Minimum probe length for nonconductive media < 1 µS/cm	10	NAMUR electronic insert FEI58	37
Output	10	Certificates and approvals	38
Switch behavior	10	Ordering information	39
Switch-on behaviour	10	Accessories	40
Fail-safe mode	10	Protective cover	40
Switching delay	11	Seal set for stainless steel housing	40
Galvanic isolation	11	Surge arresters	40
Power supply	11	Technical information	40
Electrical connection	11	Documentation	40
Connector	11	Document function	40
Cable entry	12		
Performance characteristics	12		
Reference operating conditions	12		
Switch point	12		
Ambient temperature effect	12		
Installation	12		
Mounting requirements	12		
Environment	18		
Ambient temperature range	18		
Storage and transport	18		
Climate class	18		
Shock resistance	18		
Degree of protection	18		
Vibration resistance	18		
Cleaning	19		
Electromagnetic compatibility (EMC)	19		
Process	19		
Process temperature range	19		
Process pressure and temperature derating	20		
Process pressure limits	21		
Temperature-derating separate housing	21		

Document information

Document conventions

Safety symbols

DANGER

This symbol alerts you to a dangerous situation. Failure to avoid this situation will result in serious or fatal injury.

WARNING

This symbol alerts you to a dangerous situation. Failure to avoid this situation can result in serious or fatal injury.

CAUTION

This symbol alerts you to a dangerous situation. Failure to avoid this situation can result in minor or medium injury.

NOTICE

This symbol contains information on procedures and other facts which do not result in personal injury.

Electrical symbols



Alternating current



Direct current and alternating current



Direct current



Ground connection

A grounded terminal which, as far as the operator is concerned, is grounded via a grounding system.

Protective earth (PE)

Ground terminals that must be connected to ground prior to establishing any other connections.

The ground terminals are located on the interior and exterior of the device:

- Interior ground terminal: protective earth is connected to the mains supply.
- Exterior ground terminal: device is connected to the plant grounding system.

Tool symbols



Phillips head screwdriver



Flat blade screwdriver



Torx screwdriver



Allen key



Open-ended wrench

Symbols for certain types of information and graphics

Permitted

Procedures, processes or actions that are permitted

Preferred

Procedures, processes or actions that are preferred

Forbidden

Procedures, processes or actions that are forbidden

Tip

Indicates additional information



Reference to documentation



Reference to page



Reference to graphic



Notice or individual step to be observed

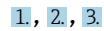

Series of steps



Result of a step



Help in the event of a problem



Visual inspection



Operation via operating tool



Write-protected parameter

1, 2, 3, ...

Item numbers

A, B, C, ...

Views



Hazardous area

Indicates the hazardous area



Safe area (non-hazardous area)

Indicates the non-hazardous area



Safety instructions

Observe the safety instructions contained in the associated Operating Instructions



Temperature resistance of the connection cables

Specifies the minimum value of the temperature resistance of the connection cables

Function and system design

Measuring principle

The principle of capacitance point level detection is based on the change in capacitance of a capacitor as a result of the probe being covered by bulk solids. The probe and container wall (conductive material) form an electric capacitor. When the probe is in air (1), a certain low initial capacitance is measured. If the container is being filled, the capacitance of the capacitor increases as more of the probe is covered (2), (3). The point level switch switches when the capacitance C_S specified during calibration is reached. In addition, a probe with inactive length ensures that the effects of medium buildup or condensate near the process connection are avoided. A probe with active buildup compensation compensates for the effects of buildup on the probe in the area of the process connection.



A ground tube is used as a counter electrode for containers made of non-conductive materials.

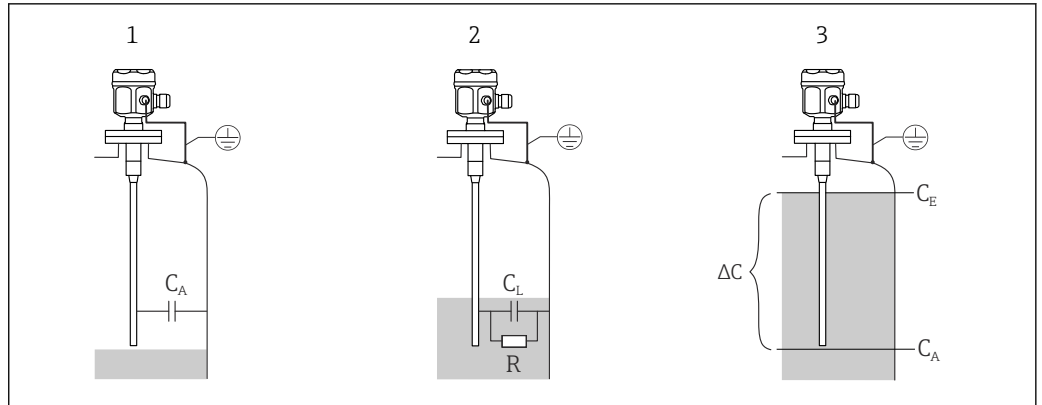

A0040662

1 Measuring principle of capacitance point level detection

- 1 The probe in the air
- 2 The probe covered by the solid
- 3 The probe covered by the solid (switching mode)
- R Conductivity of the solid
- C Capacitance of the solid
- C_A Initial capacitance when the probe is not covered
- C_S Switching capacitance
- ΔC Change in capacitance

Function The selected electronic insert of the probe determines the change in capacitance on how much the probe is covered and thereby allows precise switching at the calibrated point level.

Application examples The probe is dedicated for all bulk solids with a relative dielectric constant $\epsilon_r \geq 2.5$, like:

- sand
- glass aggregate
- gravel
- molding sand
- lime
- crushed ore
- plaster
- aluminium shavings
- cement
- grain
- pumice
- flour
- dolomite
- sugar beet
- kaolin
- fodder and similar bulk solids

Measuring system The type of the measuring system depends to the selected electronic insert.

Point level switch

The complete measuring system consists of the point level switch Solicap M FTI55 and an electronic insert FEI51, FEI52 or FEI54.

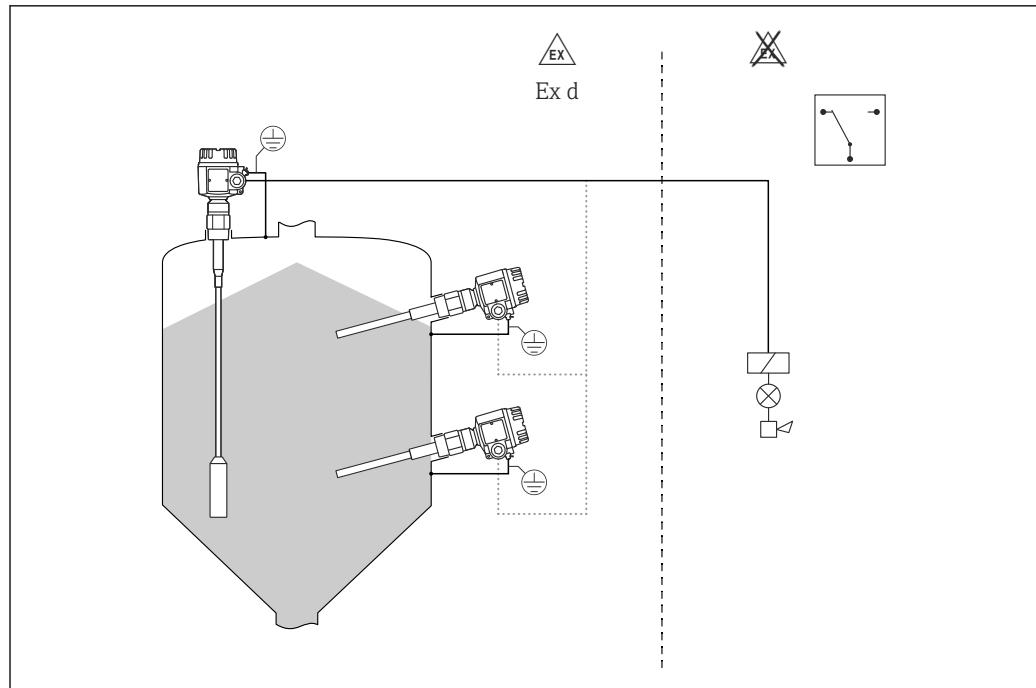

A0043989

2 Probes as a point level switch

Point level switch and separate switching unit

The Solicap M FTI55 can be used as sensor for the separate switching unit.

The complete measuring system consists of:

- the point level switch Solicap M FTI55
- the electronic insert:
 - FEI53 - non Ex areas
 - FEI57S - Ex-i areas
 - FEI58 - Ex-i areas
- a transmitter power supply unit e.g. FTC325, FTL325N

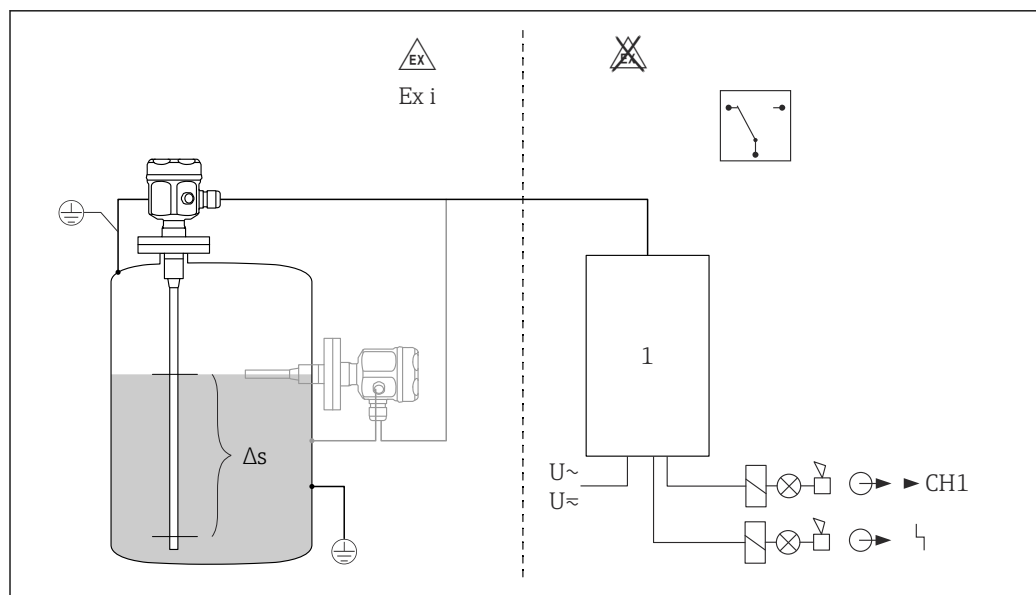

A0043992

3 Probe as the separate switching unit

1 A transmitter power supply unit

Δs Two-point control

Two-point control (Δs function)

 Use the partially insulated probes only in conjunction with non-conductive bulk solids.

The complete measuring system consists of: The device including electronic insert FE51, FEI52 or FEI54.

The point level switch can also be used to control a screw conveyor where the on and off values can be freely defined.

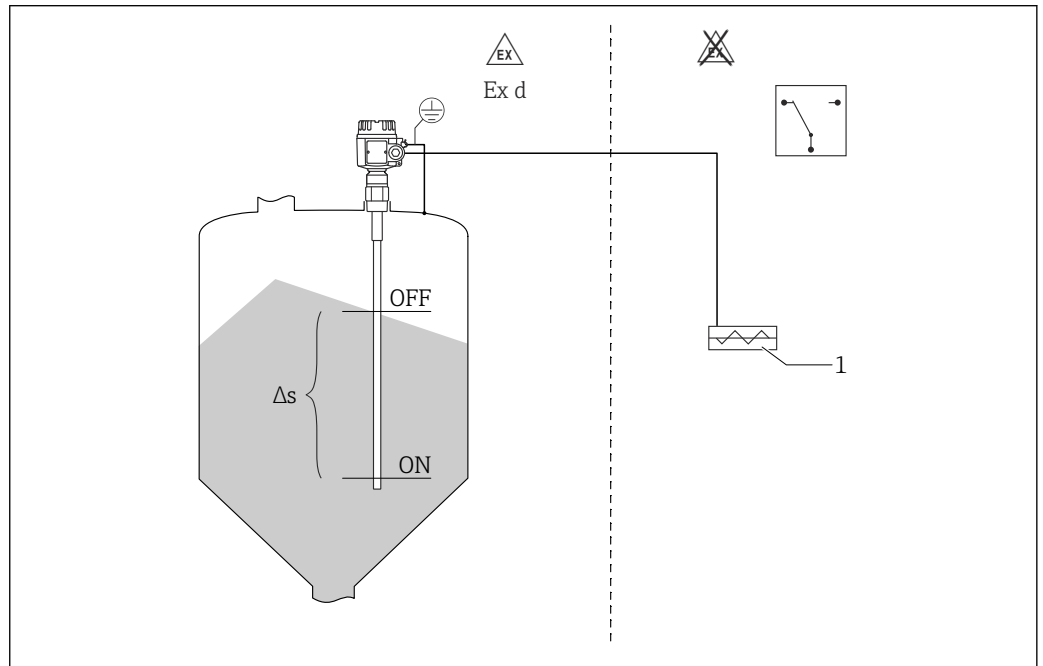

A0043990

 4 Probe as a two-point level switch

Δs Two-point control

1 Screw conveyor

Point level switch 8 mA or 16 mA

The complete measuring system consists of:

- the point level switch Solicap M FTI55
- the FEI55 electronic insert
- a transmitter power supply unit, e.g. RMA42

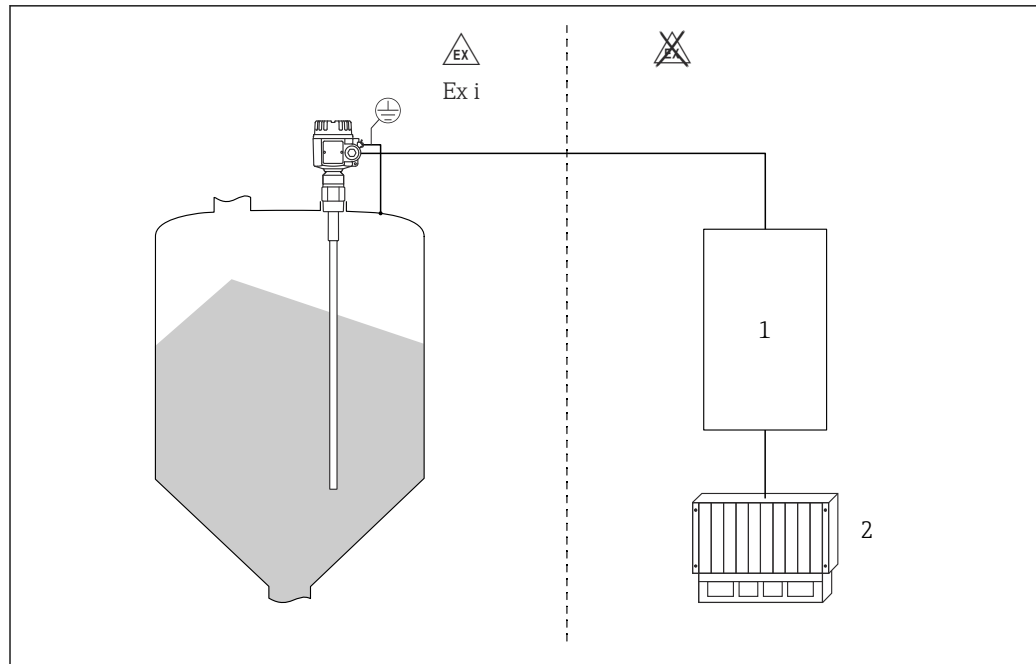

A0043994

5 The probe powered by external power supply unit

1 The transmitter power supply unit

2 PLC

Electronic inserts

FEI51

Two-wire AC connection

- Load switched directly into the power supply circuit via the thyristor
- Point level adjustment directly at the point level switch

FEI52

3-wire direct current version

- Switch the load via the transistor (PNP) and separate supply voltage connection
- Point level adjustment directly at the point level switch

FEI53

3-wire direct current version with 3 to 12 V signal output

- For separate switching unit, Nivotester FTC325 3-WIRE
- Point level adjustment directly at the switching unit

FEI54

Universal current version with relay output

- Switch the loads via 2 floating changeover contacts (DPDT)
- Point level adjustment directly at the point level switch

FEI55

Signal transmission 8 mA or 16 mA on two-wire cable

- SIL2 approval for the hardware
- SIL3 approval for the software
- For separate switching unit, e.g. RMA42
- Point level adjustment directly at the point level switch

FEI57S

PFM signal transmission (current pulses are superimposed on the supply current)

- For separate switching unit with PFM signal transmission e.g. Nivotester FTC325 PFM
- Self-test from the switching unit without changing levels
- Point level adjustment directly at the point level switch
- Cyclical checking from the switching unit

FEI58 (NAMUR)

Signal transmission H-L edge 2.2 to 3.5 or 0.6 to 1.0 mA as per IEC 60947-5-6 on two-wire cable

- For a separate switching unit, e.g. Nivotester FTL325N
- Point level adjustment directly at the point level switch
- Test the connection cables and slaves by pressing the button on the electronic insert

System integration via Fieldgate**Vendor managed inventory**

The remote interrogation of tank or silo levels via Fieldgate enables suppliers of raw materials to gather information about the current inventories of their regular customers at any time and, for example, to take this into account in their own production planning. The Fieldgate monitors the configured point levels and automatically triggers the next order as required. Here, the range of possibilities ranges from simple requisitioning by e-mail through to fully automatic order processing by incorporating XML data into the planning systems on both sides.

Remote maintenance of measuring systems

Not only does Fieldgate transmit the current measured values, it also alerts the standby personnel responsible by e-mail or SMS as required. Fieldgate forwards the information transparently. In this way, all options of the operating software in question are available remotely. By using remote diagnosis and remote configuration some onsite service operations can be avoided and all others can at least be planned and prepared better.

Input

Measured variable	Measurement of the change in capacitance between the probe and the tank wall, depending on the level of the bulk solids.
Measuring range	<p>Measuring frequency 500 kHz</p> <p>Span</p> <ul style="list-style-type: none"> ▪ $\Delta C = 5$ to 1 600 pF ▪ FEI58 $\Delta C = 5$ to 500 pF <p>Final capacitance $C_E =$ maximum 1 600 pF</p> <p>Adjustable initial capacitance</p> <ul style="list-style-type: none"> ▪ range 1 - factory setting $C_A = 5$ to 500 pF ▪ range 2 - not available with FEI58 $C_A = 5$ to 1 600 pF
Input signal	<p>Probe covered -> high capacitance</p> <p>Probe not covered -> low capacitance</p>
Measuring conditions	<p>When installing in a nozzle, use inactive length (L3). Rod probes can be used to control a screw conveyor (Δs mode). The on-value and off-value are determined by the empty and full calibration. Partially insulated probes are only suitable for nonconductive bulk solids.</p> <ul style="list-style-type: none"> ▪ $DK > 10$: measuring range up to 4 m (13 ft) ▪ $5 < DK < 10$: measuring range up to 12 m (39 ft) ▪ $2 < DK < 5$: measuring range up to 20 m (66 ft) <p>The minimum capacitance change for point level detection must be ≥ 5 pF.</p>

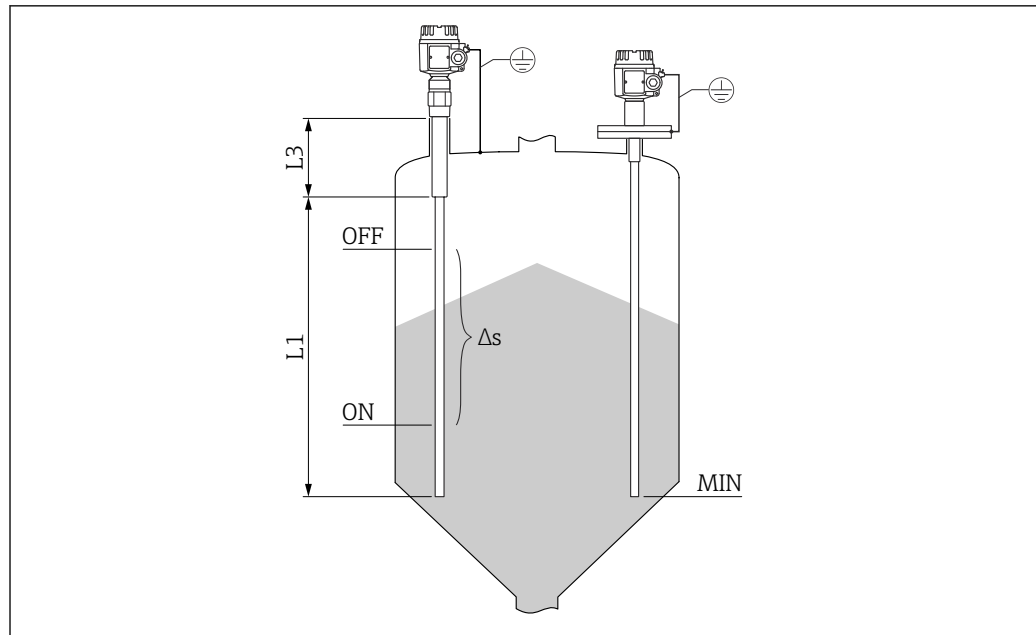

A0043996

6 Measuring conditions overview

$L1$ Active length

$L3$ Inactive length

Δs Two-point control

MIN Minimum measuring level

Minimum probe length for nonconductive media < 1 $\mu\text{S}/\text{cm}$

The minimum probe length can be calculated using the formula:

$$l_{\min} = \frac{\Delta C_{\min}}{C_s \cdot (\epsilon_r - 1)}$$

A0040204

l_{\min}	minimum probe length
ΔC_{\min}	5 pF
C_s	probe capacitance in air
ϵ_r	relative dielectric constant, e.g. for dried grain = 3.0

Output

Switch behavior

Binary or Δs operation.



The pump control is not possible with FEI58.

Switch-on behaviour

When the power supply is switched on, the switching status of the outputs corresponds to the signal on the alarm.

The correct switch condition is reached after a maximum of 3 s.

Fail-safe mode

Minimum and maximum quiescent current safety can be switched at the electronic insert ¹⁾.

1) For FEI53 and FEI57S only on the associated Nivotester: FTC325.

MIN

Minimum safety: the output switches safety-oriented when the probe is uncovered ²⁾ (signal on alarm).

MAX

Maximum safety: the output switches safety-oriented when the probe is covered ³⁾ (signal on alarm).

Switching delay**FEI51, FEI52, FEI54, FEI55**

Can be adjusted incrementally at the electronic insert: 0.3 to 10 s.

FEI53, FEI57S

Depends on the connected Nivotester (transmitter): FTC325.

FEI58

Can be adjusted alternately at the electronic insert: 1 s or 5 s

Galvanic isolation**FEI51 and FEI52**

between the probe and power supply

FEI54

between the probe, power supply and load

FEI53, FEI55, FEI57S and FEI58

see connected switching device ⁴⁾

Power supply

Electrical connection

Depending on explosion protection, the connection compartment is available in the following variants:

Standard protection, Ex ia protection

- polyester housing F16
- stainless steel housing F15
- aluminum housing F17
- aluminum housing F13 with gas-tight process seal
- stainless steel housing F27 with gas-tight process seal
- aluminum housing T13 with a separate connection compartment

Ex d protection, Gas-tight process seal

- aluminum housing F13 with gas-tight process seal
- stainless steel housing F27 with gas-tight process seal
- aluminum housing T13 with a separate connection compartment

Connector

For the version with a connector M12, the housing does not have to be opened for connecting the signal line.

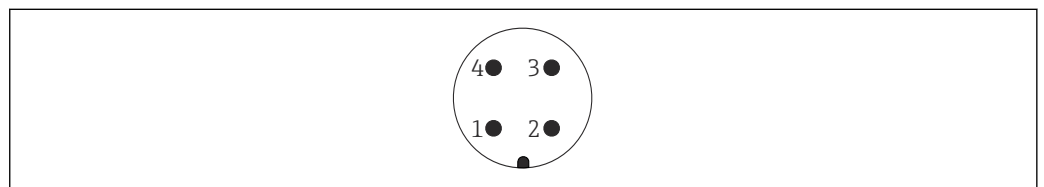
PIN assignment for M12 connector

A0011175

 7 M12 connector with 2-wire-electronic insert FEI55, FEI57, FEI58, FEI57C

- 1 Positive potential
- 2 Not used
- 3 Negative potential
- 4 Ground

2) E.g. for dry running protection and pump protection.

3) E.g. for use with overflow protection.

4) Functional galvanic isolation in the electronic insert.

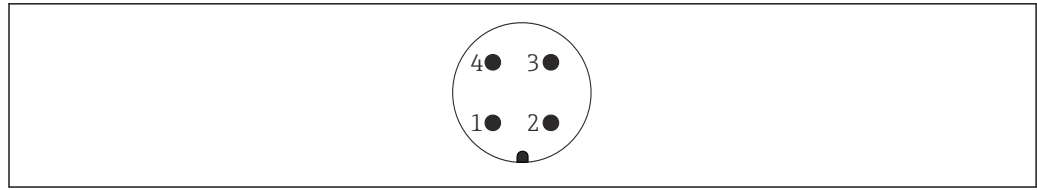

A0011175

8 M12 connector with 3-wire-electronic insert FEI52, FEI53

- 1 Positive potential
- 2 Not used
- 3 Negative potential
- 4 External load / signal

Cable entry

Cable gland

M20x1.5 for Ex d only cable entry M20
Two cable glands are included in scope of delivery.

Cable entry

- G $\frac{1}{2}$
- NPT $\frac{1}{2}$
- NPT $\frac{3}{4}$
- M20 thread

Performance characteristics

Reference operating conditions

Temperature: 20 °C (68 °F) \pm 5 °C (\pm 8 °F)
Pressure: 1013 mbar (407 inH₂O) abs. \pm 20 mbar (\pm 8.03 inH₂O)
Humidity: 65 % \pm 20 %
Medium: water from mains (conductivity 180 μ S/cm)

Switch point

Uncertainty as per DIN 61298-2: max. \pm 0.3 %
Non-repeatability (reproducibility) as per DIN 61298-2: max. \pm 0.1 %

Ambient temperature effect

Electronic insert

< 0.06 % per 10 K related to the full-scale value

Separate housing

capacitance change of connecting cable per meter 0.15 pF per 10 K

Installation

Mounting requirements

General notes and precautions

NOTICE

Filling the silo.

- ▶ The filling stream must not be directed onto the probe.

NOTICE

Angle of material flow.

- ▶ Take care to the expected angle of the material flow and the outlet funnel when determining the mounting location or probe length.

NOTICE

Distance between probes.

- ▶ The minimum distance of 500 mm (19.7 in) between the probes must be observed.

NOTICE

Threaded coupling for mounting.

- ▶ The threaded coupling must be as short as possible. Condensation or product residue can occur in a long threaded coupling and interfere with the correct operation of the probe.

NOTICE

Heat insulation

- ▶ Insulate the external silo wall to avoid exceeding the permitted temperature of the Solicap M housing.
- ▶ Insulate the silo wall to prevent the condensation and reduce buildup in the threaded coupling area.

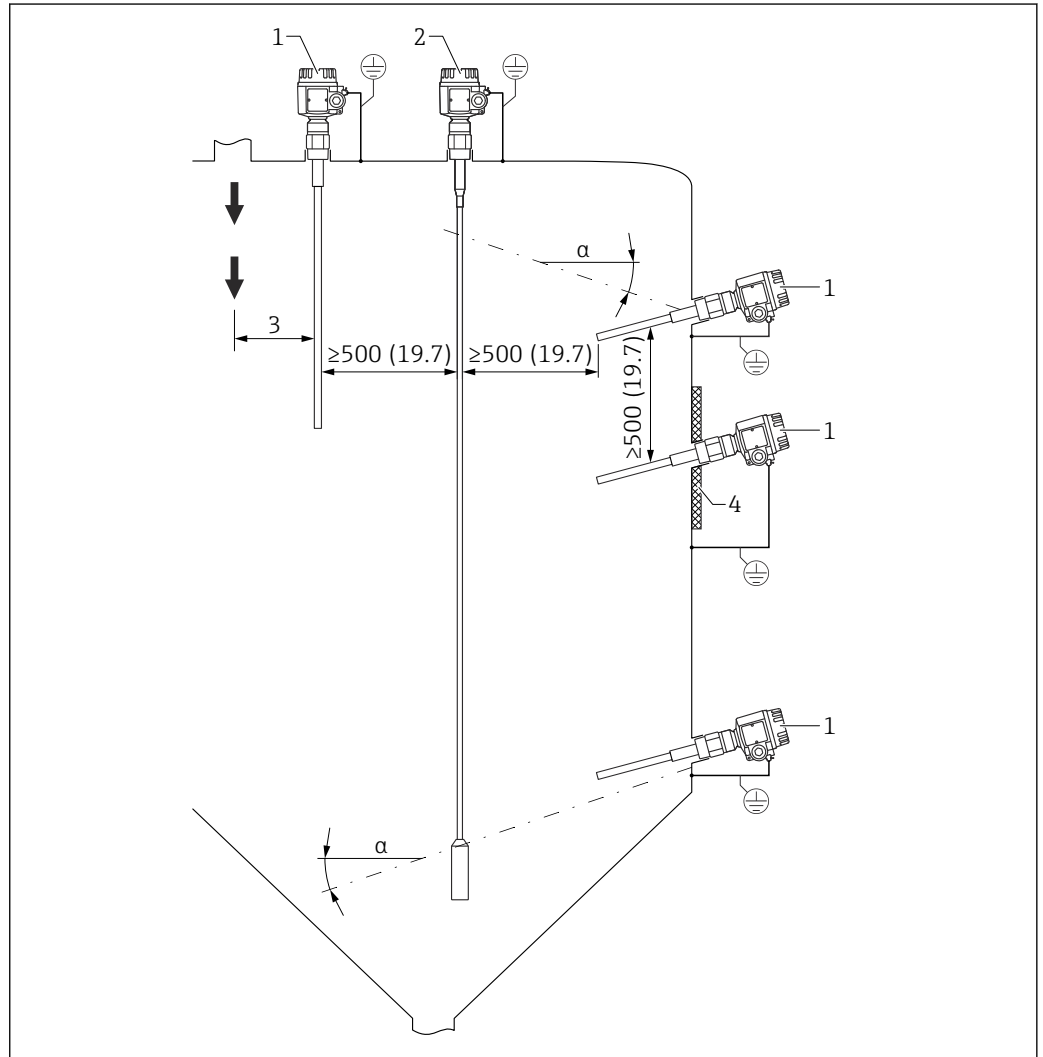

A0043999

9 Mounting examples. Unit of measurement mm (in)

- a* Angle of the slope
- 1 FTI55
- 2 FTI56
- 3 Distance from the loading point
- 4 Heat insulation

Mounting the sensor

The Solicap M FTI55 can be mounted:

- from above
- from the side

NOTICE

Mouting the probe rod in the loading curtain area can cause a incorrect device operation!

- ▶ Mount the probe away from the loading curtain.

NOTICE

The probe rod cannot touch the metal container wall!

- ▶ Make sure that the probe rod is insulated from the metal container wall.

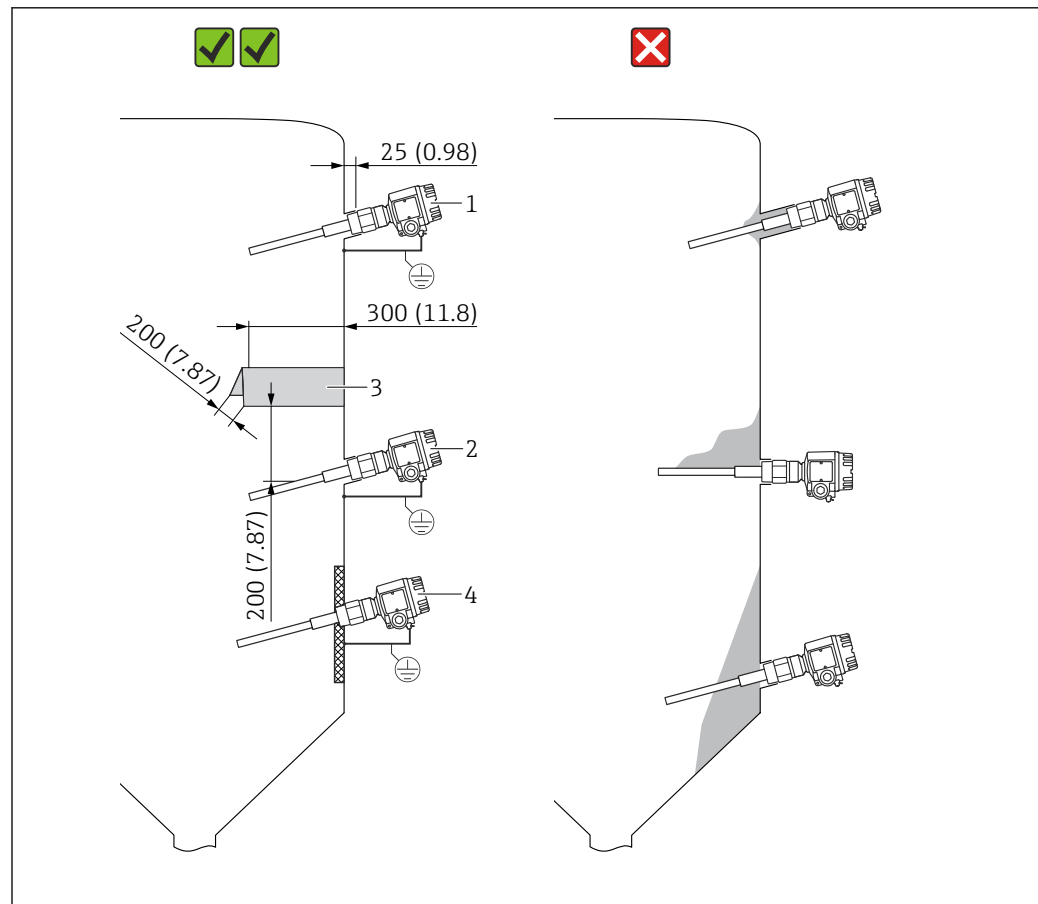

10 Side mounting of the probe. Unit of measurement mm (in)

- 1 For maximum level limit detection
- 2 For minimum point level detection
- 3 The protective cover protects the probe rod from collapsing mounds or mechanical strain at the outflow.
- 4 In the event of light buildup on the silo wall, the threaded coupling is welded internally. The probe tip points slightly downwards so that bulk solids slide off more easily.

Installing the probe in a silo with concrete walls

The grounded steel plate forms the counter electrode. The heat insulation prevents condensation and therefore buildup on the steel plate. The steel plate can be a round or square shape.

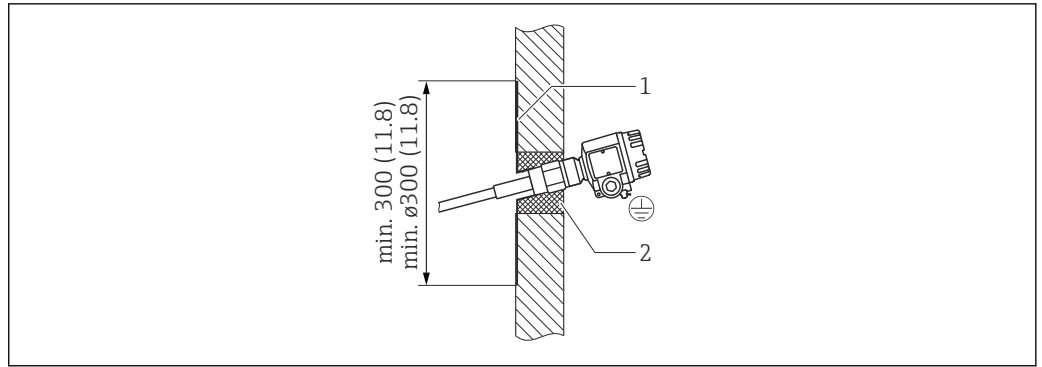

A0044001

11 Probe installed in a concrete wall

- 1 Sheet metal plate with threaded socket
- 2 Heat insulation

Installing the probe in a silo with plastic walls

If the probe is installed in the silo with plastic walls, a sheet metal plate must be attached to the exterior of the silo as a counters electrode. The plate can be in square or round shape.

The dimensions of the plate are:

- approximately square of 500 mm (19.7 in) each side or round \varnothing 500 mm (19.7 in) for thin wall with low dielectric constant
- approximately square of 700 mm (27.6 in) each side or round \varnothing 700 mm (27.6 in) for thick wall with high dielectric constant

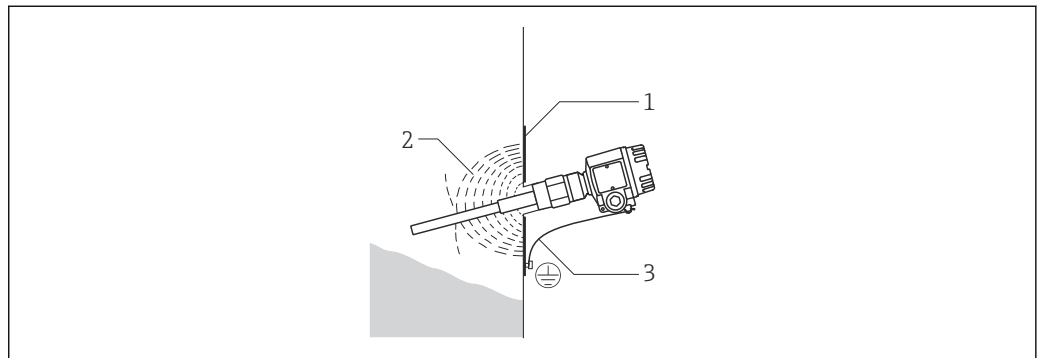

A0044002

12 Probe installed in the plastic wall

- 1 Sheet metal plate
- 2 Electrical HF field
- 3 Ground connection

Probe with separate housing

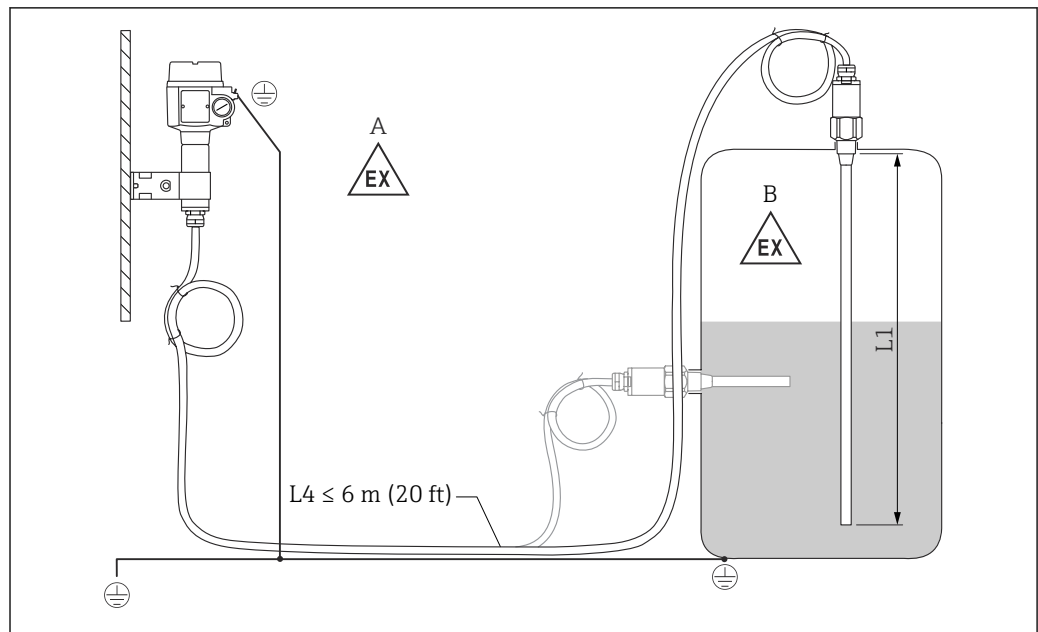

13 Connection of the probe and separate housing

- A Explosive zone 1
 B Explosive zone 0
 L1 Rod length: max. 4 m (13 ft)
 L4 Cable length

The maximum cable length L4 and rod length L1 cannot exceed 10 m (33 ft).

- i** The maximum cable length between the probe and separate housing is 6 m (20 ft).
- The required cable length must be indicated in the ordering process of a Liquicap M with separate housing.
- If the cable connection has to be shortened or led through a wall, then it must be separated from the process connection.

Extension heights: separate housing

- i** The cable has:
 - a minimum bending radius of $r \geq 100$ mm (3.94 in)
 - \varnothing 10.5 mm (0.41 in)
 - outer jacket made of silicone, notch resistance

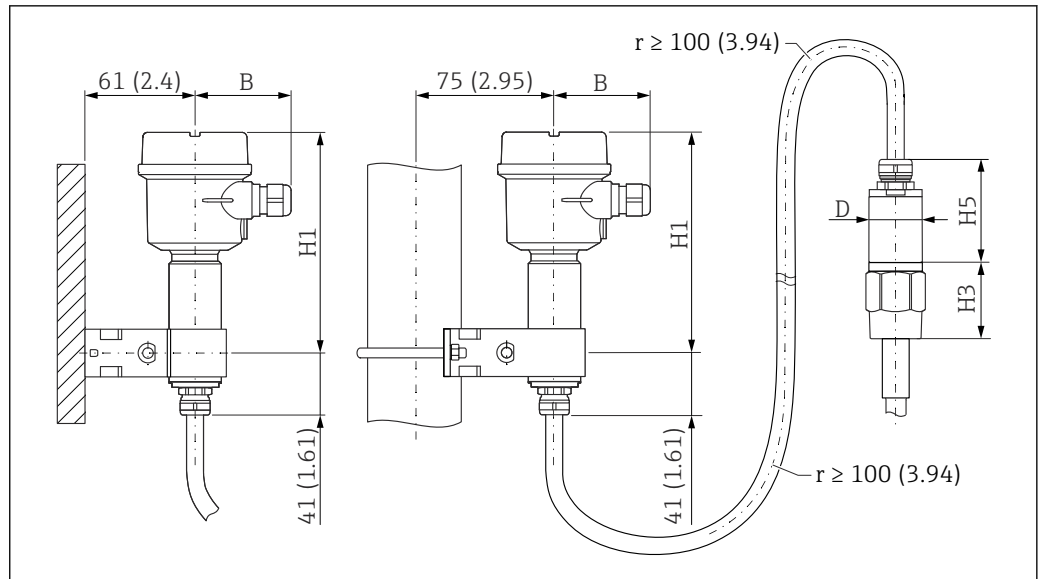

A0044370

14 Housing side: wall mounting, pipe mounting, and sensor side. Unit of measurement mm (in)

Values of parameters ⁵⁾:

B parameter

- polyester housing (F16): 76 mm (2.99 in)
- stainless steel housing (F15): 64 mm (2.52 in)
- aluminum housing (F17): 65 mm (2.56 in)

H1 parameter

- polyester housing (F16): 172 mm (6.77 in)
- stainless steel housing (F15): 166 mm (6.54 in)
- aluminum housing (F17): 177 mm (6.97 in)

D parameter

∅ 50 mm (1.97 in)

H5 parameter

∅ 62 mm (2.44 in)

H3 parameter value

The height H3 depends on the type of process connection.

Wall bracket

-  The wall bracket is a part of the scope of delivery.
- To use the wall bracket as a drill template, the wall bracket must be first screwed to the separate housing.
- The distance between the holes is reduced by screwing it to the separate housing.

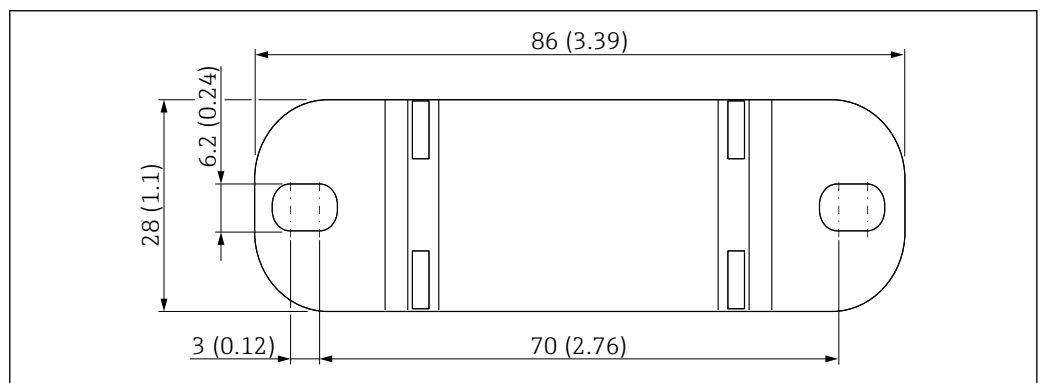

A0033881

15 Wall bracket overview. Unit of measurement mm (in)

5) See parameters on the drawings.

Environment

Ambient temperature range	<ul style="list-style-type: none"> ■ F16 housing: -40 to +70 °C (-40 to +158 °F) ■ remaining housing: -50 to +70 °C (-58 to +158 °F) ■ observe derating ■ use a protective cover, when operating outdoors
Storage and transport	For storage and transportation, pack the device to protect it against impact. The original packing offers the best protection for this. The permitted storage temperature is -50 to +85 °C (-58 to +185 °F).
Climate class	DIN EN 60068-2-38/IEC 68-2-38: Z/AD check
Shock resistance	DIN EN 60068-2-27/IEC 68-2-27: 30 g acceleration
Degree of protection	<p> All protection degree regarding EN60529. Type4X protection degree regarding NEMA250.</p> <p>Polyester housing F16 Protection degree:</p> <ul style="list-style-type: none"> ■ IP66 ■ IP67 ■ Type4X <p>Stainless steel housing F15 Protection degree:</p> <ul style="list-style-type: none"> ■ IP66 ■ IP67 ■ Type4X <p>Aluminum housing F17 Protection degree:</p> <ul style="list-style-type: none"> ■ IP66 ■ IP67 ■ Type4X <p>Aluminum housing F13 with gas-tight process seal Protection degree:</p> <ul style="list-style-type: none"> ■ IP66 ■ IP68 ⁶⁾ ■ Type4X <p>Stainless steel housing F27 with gas-tight process seal Protection degree:</p> <ul style="list-style-type: none"> ■ IP66 ■ IP67 ■ IP68 ⁶⁾ ■ Type4X <p>Aluminum housing T13 with gas-tight process seal and separate connection compartment (Ex d) Protection degree:</p> <ul style="list-style-type: none"> ■ IP66 ■ IP68 ⁶⁾ ■ Type4X <p>Separate housing Protection degree:</p> <ul style="list-style-type: none"> ■ IP66 ■ IP68 ⁶⁾ ■ Type4X
Vibration resistance	DIN EN 60068-2-64/IEC 68-2-64: 20 to 2 000 Hz, 0.01 g ² /Hz

6) Only with M20 cable entry or G½ thread.

Cleaning

Housing

Make sure that the cleaning agent used does not corrode the housing surface or the seals.

Probe

Depending on the application, buildup (contamination and soiling) can form on the probe rod. A high degree of material buildup can affect the measurement result. If the medium tends to create a high degree of buildup, regular cleaning is recommended. When cleaning, it is important to make sure that the insulation of the probe rod is not damaged. Make sure the material is resistant to used cleaning agent.

Electromagnetic compatibility (EMC)

Interference emission to EN 61326, Electrical Equipment Class B. Interference immunity to EN 61326, Annex A (Industrial) and NAMUR Recommendation NE 21 (EMC).

A standard commercial instrument cable can be used.

 Information on connecting shielded cables is provided in Technical Information TI00241F "EMC test procedures".

Process

Process temperature range

The following process temperature ranges only apply for standard applications outside hazardous areas.

 Regulations for use in hazardous areas are provided in the Supplementary Documentation that is available for the product and can be selected via the Product Configurator at www.endress.com.

Permitted ambient temperature T_a at the housing depending on the process temperature T_p in the tank.

Rod probe FTI55

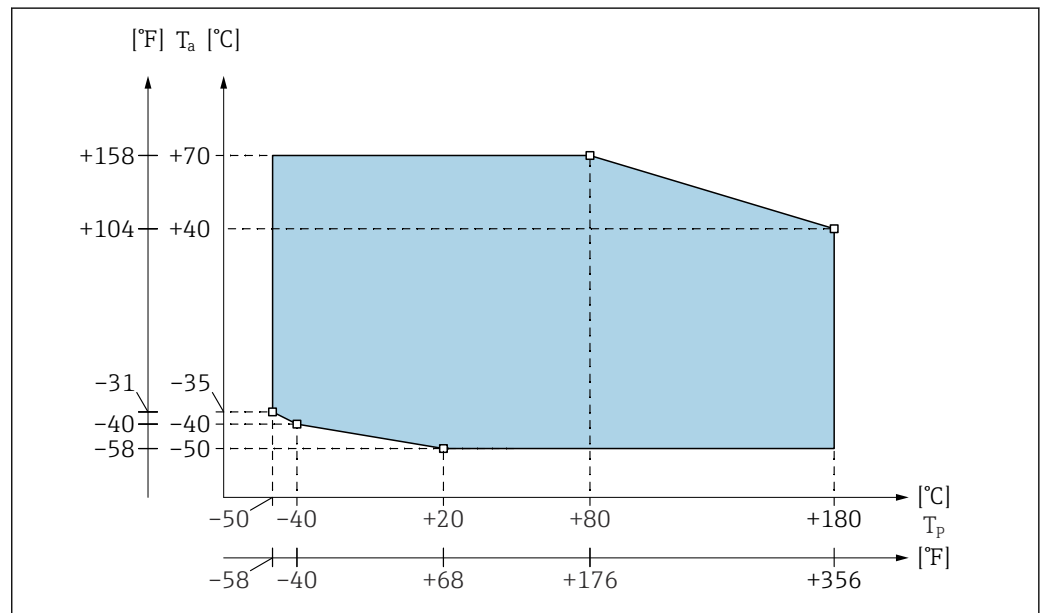

 16 Partially insulated probe

A0044014

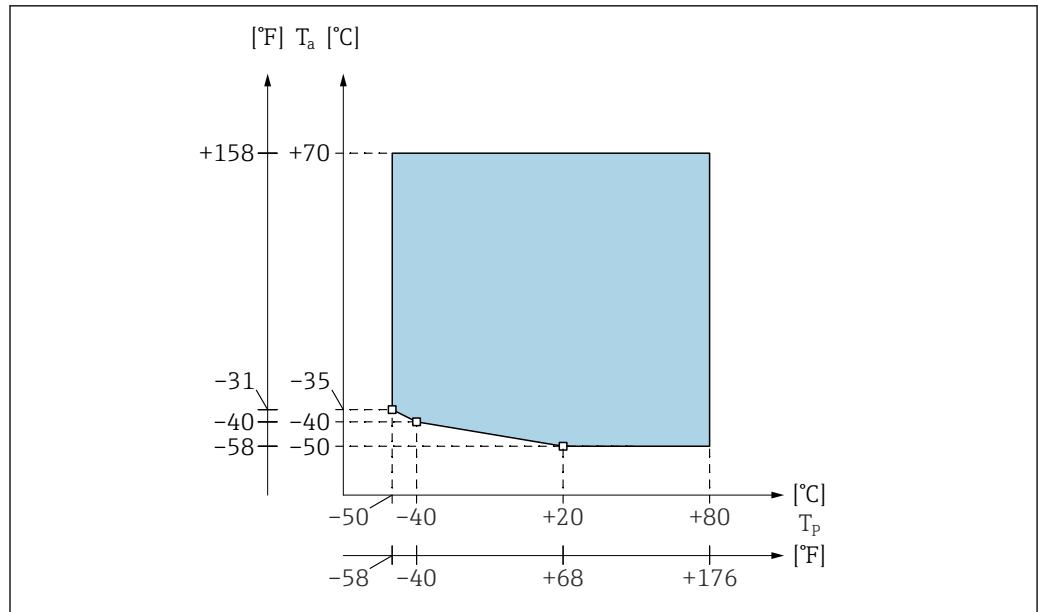

A0044015

17 Fully insulated probe

i Restriction to $T_a -40^{\circ}\text{C}$ (-40°F) for polyester housing F16.

Process pressure and temperature derating

The lowest value from the derating curves of the device and the selected flange applies. In the case of flange process connections, the maximum pressure is limited by the nominal pressure of the flange.

Rod probe FTI55

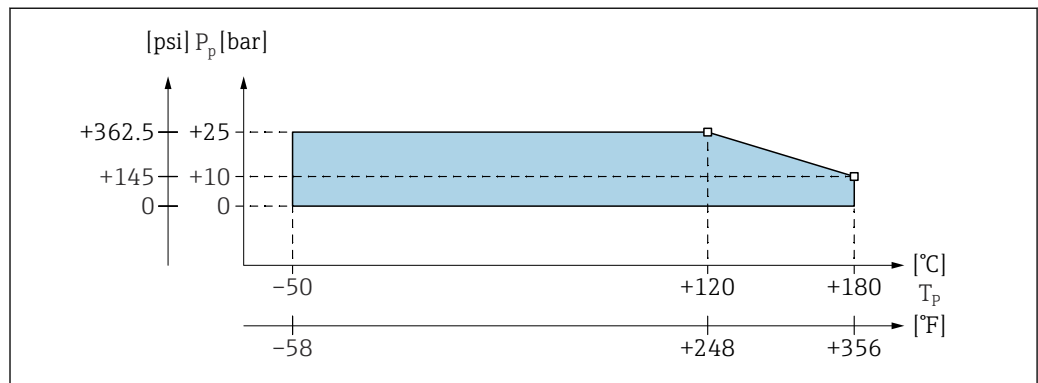

A0044017

18 Partially insulated probe

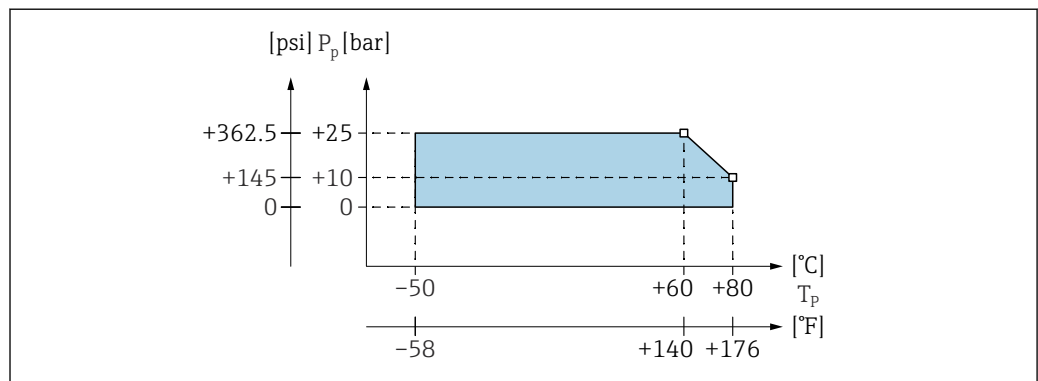

A0044018

19 Fully insulated probe

Process pressure limits

Process pressure limits: -1 to 25 bar (-14.5 to 362.5 psi).

The lowest value from the derating curves of the device and the selected flange applies.

Refer to the following standards for the pressure values permitted at higher temperatures:

- pR EN 1092-1: 2005 Table, Appendix G2
 With regard to its resistance and temperature property, the material 1.4435 is identical to 1.4404 (AISI 316L) which is grouped under 13E0 in EN 1092-1 Tab. 18. The chemical make-up of the two materials can be identical.
- ASME B 16.5a - 1998 Tab. 2-2.2 F316
- ASME B 16.5a - 1998 Tab. 2.3.8 N10276
- JIS B 2220

Temperature-derating separate housing

 The temperature at the separate housing must not exceed 70 °C (158 °F).

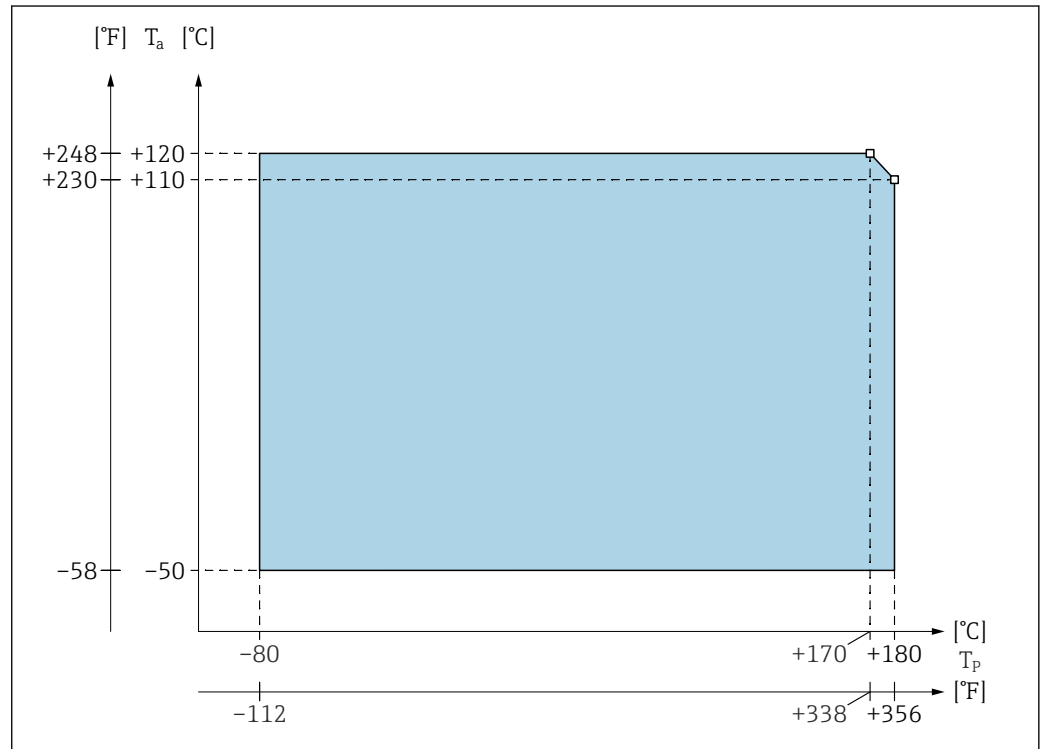

 20 Process pressure range diagram

T_a Ambient temperature

T_p Process temperature

The maximum connection length between the probe and the separate housing is 6 m (L4). When ordering a device with a separate housing, the desired length must be specified. If the connecting cable is to be shortened or passed through a wall, it must be separated from the process connection, see operating instructions.

Mechanical construction

Housing

Polyester housing F16

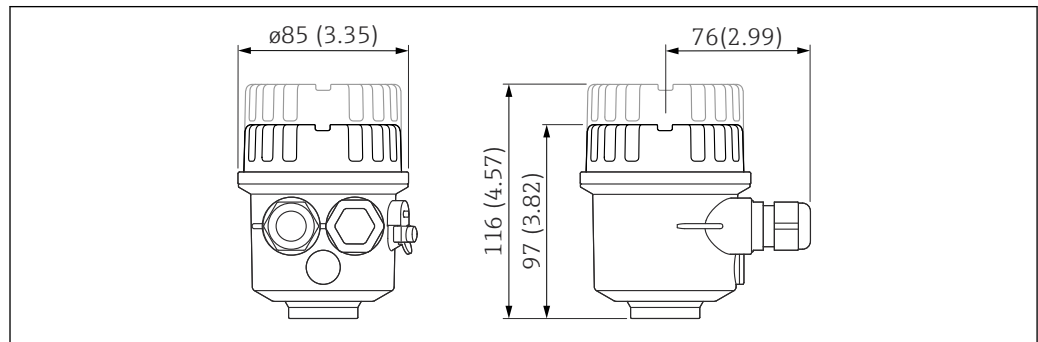

A0040691

Unit of measurement mm (in)

Stainless steel housing F15

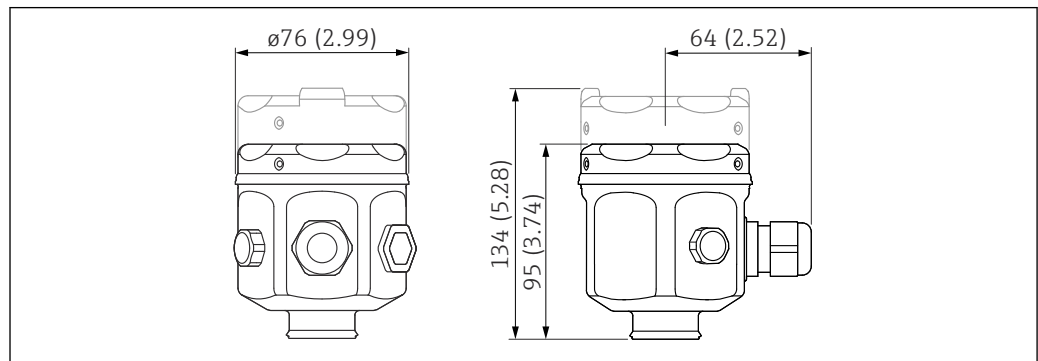

A0040692

Unit of measurement mm (in)

Stainless steel housing F17

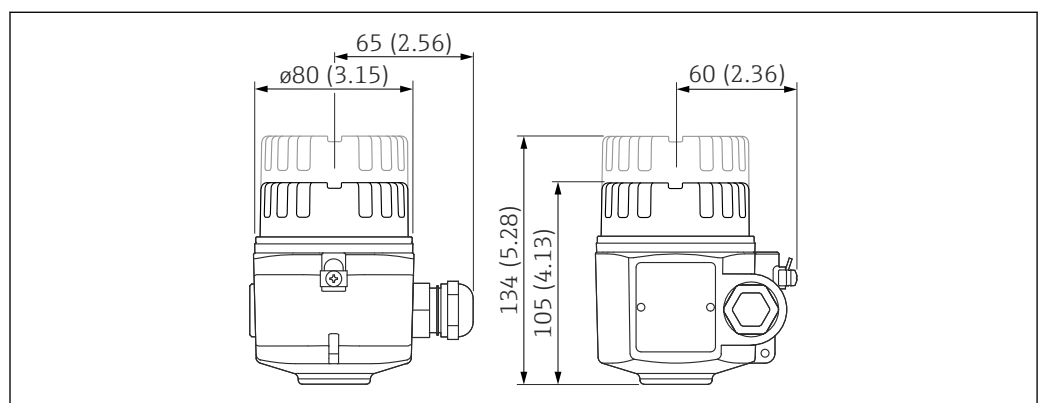

A0040693

Unit of measurement mm (in)

Aluminum housing F13

With the gas-tight process seal.

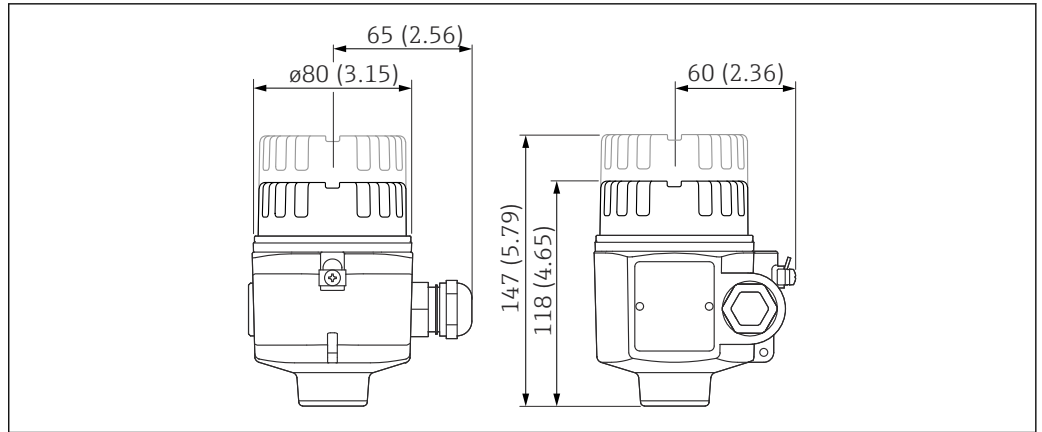

A0040694

Unit of measurement mm (in)

Stainless steel housing F27

With the gas-tight process seal.

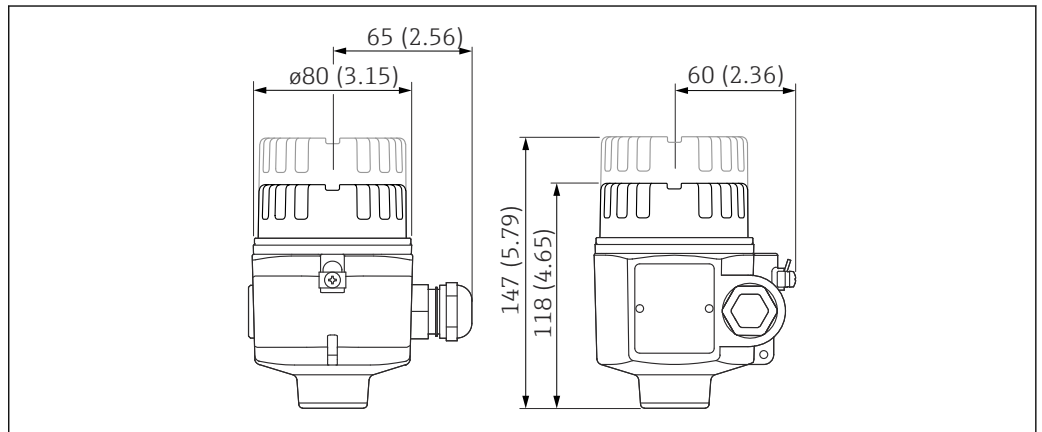

A0040694

Unit of measurement mm (in)

Aluminum housing T13

With separate connection compartment and gas-tight process seal.

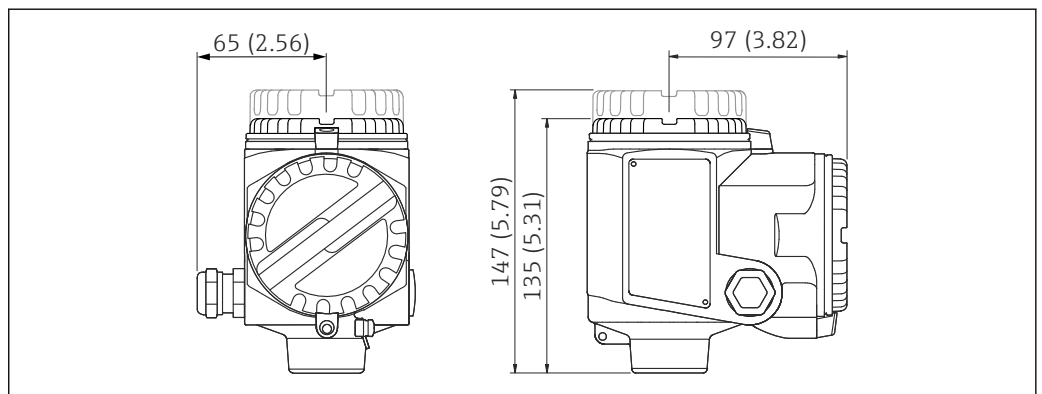

A0040695

Unit of measurement mm (in)

Housing heights with adapter

List of abbreviations:

- G - order code
- H1 - height

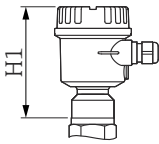
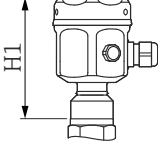
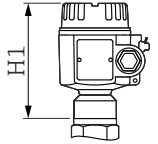
A ¹⁾	B ²⁾	C ³⁾
 <small>A0044020</small>	 <small>A0044021</small>	 <small>A0044022</small>
G: 2	G: 1	G: 3
125 mm (4.92 in)	121 mm (4.76 in)	131 mm (5.16 in)

- 1) Polyester housing F16
- 2) Stainless steel housing F15
- 3) Aluminum housing F17

List of abbreviations:

- G - order code
- H1 - height

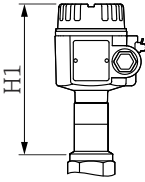
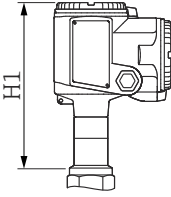
D ¹⁾	F ²⁾
 <small>A0044023</small>	 <small>A0044024</small>
G: 4	G: 5
177 mm (6.97 in)	194 mm (7.64 in)

- 1) Aluminum housing F13 with gas-tight process seal
- 2) Aluminum housing with separate connection compartment T13 and gas-tight process seal

Process connections and flanges

Thread: R 1½ - DIN EN 10226-1

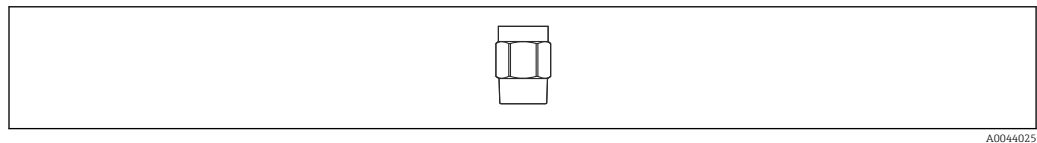

- p_{max}: 25 bar (362.5 psi)
- Order code
 - 316L: RVJ
 - steel: RV1

Thread: NPT 1½ - ANSI B 1.20.1

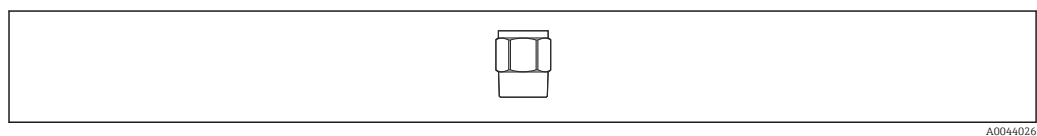

- p_{max} : 25 bar (362.5 psi)
- Order code
 - 316L: **RGJ**
 - steel: **RG1**

Flanges

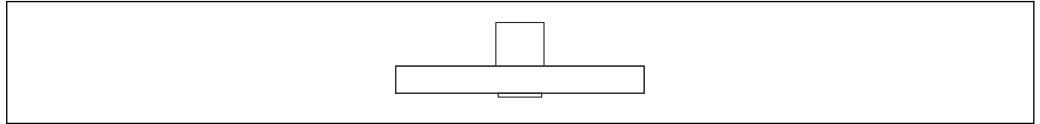

A0044027

- p_{max} : 25 bar (362.5 psi) ⁷⁾
- Order code
 - ASME B16.5, NPS 2" Cl.150 RF, 316/316L: **AFJ**
 - ASME B16.5, NPS 3" Cl.150 RF, 316/316L: **AGJ**
 - ASME B16.5, NPS 4" Cl.150 RF, 316/316L: **AHJ**
 - EN1092-1, DN80 PN10/16 A, 316L: **BSJ**
 - EN1092-1, DN100 PN10/16 A, 316L: **BTJ**
 - EN1092-1, DN50 PN25/40 A, 316L: **B3J**
 - JIS B2220, 10K 50A RF, 316L: **KFJ**
 - JIS B2220, 10K 80A RF, 316L: **KGJ**
 - JIS B2220, 10K 100A RF, 316L: **KHJ**

Rod probes FTI55

- i** Total length of the probe measured from the start of the thread:
 - without active buildup compensation: $L = L1 + L3$
 - with active buildup compensation: $L=L1+L3+125\text{ mm (4.92 in)}$
- i** Length tolerance:
 - up to 1 m (3.3 ft): 0 to -5 mm (0 to -0.2 in)
 - > 1 to 3 m (3.3 to 9.8 ft): 0 to -10 mm (0 to -0.39 in)
 - > 3 to 6 m (9.8 to 20 ft): 0 to -20 mm (0 to -0.79 in)

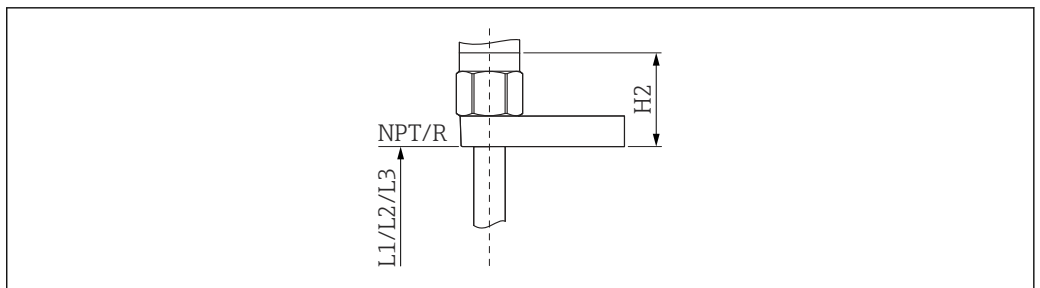

A0044028

7) Depends on flange

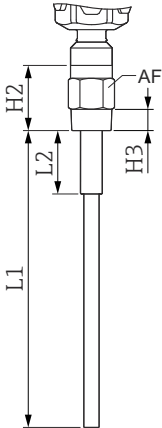
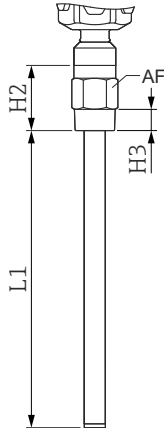
A ¹⁾	B ²⁾
	
A0044029	A0044030
H2	
77 mm (3.03 in)	77 mm (3.03 in)
H3	
25 mm (0.98 in)	25 mm (0.98 in)
AF	
50	50
Total length (L)	
200 to 4 000 mm (7.87 to 157 in)	200 to 4 000 mm (7.87 to 157 in)
Active rod length (L1)	
200 to 4 000 mm (7.87 to 157 in)	200 to 4 000 mm (7.87 to 157 in)
Length of partial insulation (L2)	
75 mm (2.95 in)	-
Inactive rod length (L3)	
-	-
Inactive length diameter	
-	-
Probe rod diameter	
18 mm (0.71 in)	18 mm (0.71 in)
Probe rod diameter with insulation	
26 mm (1.02 in)	26 mm (1.02 in)
Active build-up compensation diameter	
-	-
Active build-up compensation length	
-	-
Lateral loading capacity at 20 °C (68 °F)	
300 Nm (221 lbf ft)	300 Nm (221 lbf ft)
Maximum process temperature	
180 °C (356 °F)	80 °C (176 °F)
Probe can be used in mounting nozzles	
-	-

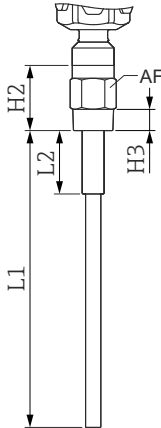
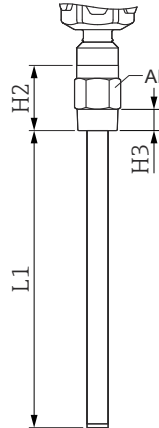
A ¹⁾	B ²⁾
	
A0044029	A0044030
Probe can be used in the event of condensate on tank ceiling	
-	-

- 1) Rod probe partially insulated
- 2) Rod probe fully insulated

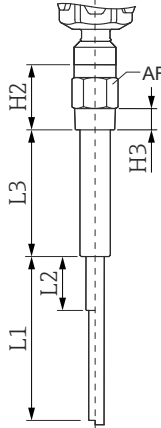
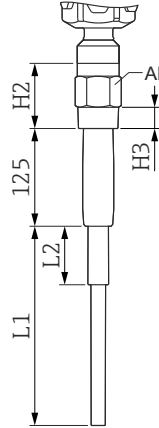
C ¹⁾	D ²⁾
	
A0044031	A0044032
H2	
66 mm (2.6 in)	92 mm (3.62 in)
H3	
25 mm (0.98 in)	25 mm (0.98 in)
AF	
50	50
Total length (L)	
300 to 6000 mm (11.8 to 236 in)	225 to 4000 mm (8.86 to 157 in)
Active rod length (L1)	
200 to 4000 mm (7.87 to 157 in)	200 to 4000 mm (7.87 to 157 in)
Length of partial insulation (L2)	
75 mm (2.95 in)	75 mm (2.95 in)
Inactive rod length (L3)	
200 to 2000 mm (7.87 to 78.74 in)	-
Inactive length diameter	

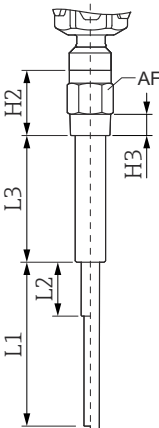
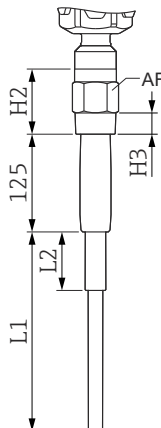
C ¹⁾		D ²⁾
		
A0044031		A0044032
43 (1.69)		-
Probe rod diameter		
18 mm (0.71 in)		18 mm (0.71 in)
Probe rod diameter with insulation		
26 mm (1.02 in)		26 mm (1.02 in)
Active build-up compensation diameter		
-		36 mm (1.42 in)
Active build-up compensation length		
-		125 mm (4.92 in)
Lateral loading capacity at 20 °C (68 °F)		
300 Nm (221 lbf ft)		200 Nm (147.5 lbf ft)
Maximum process temperature		
180 °C (356 °F)	80 °C (176 °F)	180 °C (356 °F)
Probe can be used in mounting nozzles		
✓		-
Probe can be used in the event of condensate on tank ceiling		
✓		✓

- 1) Rod probe with inactive length partially or fully insulated
2) Rod probe with active buildup compensation partially insulated

Materials

Housing

- Aluminum housing F17, F13, T13: GD-Al Si 10 Mg, DIN 1725, with plastic coating (blue and gray)
- Polyester housing F16: PBT-FR fiberglass reinforced polyester (blue and gray)
- Stainless steel housing F15: corrosion-resistant steel 316L (1.4404 or 1.4405), uninsulated

Housing cover and seals

- Aluminum housing F17, F13, T13: EN-AC-ALSi10Mg, plastic-coated, cover seal: EPDM
- Polyester housing F16: cover made of PBT-FR or cover with sight glass made of PA12, cover seal: EPDM
- Stainless steel housing F15: AISI 316L, cover seal: silicone

Probe material

- Process connection: 1.4404, 316L or steel
- Inactive length: 1.4404, 316L
- Probe rod partially insulated: PPS, 1.4404 or 316L
- Probe rod fully insulated: PE, galvanized steel

Weight

Housing with process connection:

- F15, F16, F17, F13 approximately 4.00 kg (8.82 lb)
 - + flange weight or process connection
 - probe rod 2 kg/m (0.67 lb/ft) (for ø18 mm (0.71 in) probe rod)
- T13 approximately 4.50 kg (9.92 lb)
 - + flange weight or process connection
 - probe rod 2 kg/m (0.67 lb/ft) (for ø18 mm (0.71 in) probe rod)

Operability**2-wire AC electronic insert
FEI51****Power supply**

- Supply voltage: 19 to 253 V_{AC}
- Power consumption: < 1.5 W
- Residual current consumption: < 3.8 mA
- Short-circuit protection
- Overvoltage category: II

Electrical connection

 Connect the electronic insert in series with an external load.

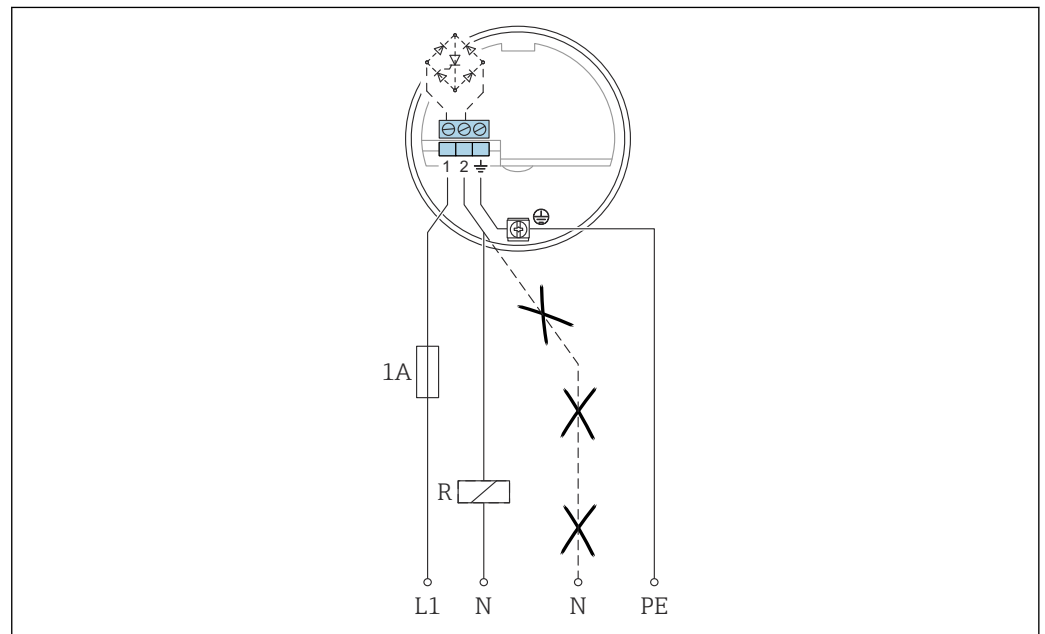

A0042387

L1 L1 phase cable
 N Neutral cable
 PE Grounding cable
 R External load

Make sure that:

- the residual current consumption is in blocked state.
- for low voltage:
 - voltage drop across the load is such that the minimum terminal voltage at the electronic insert 19 V when blocked is not undershot
 - voltage drop across the electronics when switched through is observed (up to 12 V)
 - a relay cannot de-energize with holding power below 1 mA⁸⁾

When selecting the relay, pay attention to the holding power and rated power.

8) If not: A resistor should be connected parallel to the relay (RC module available on request).

Signal on alarm

		GN	GN	RD	GN	GN	YE	
MAX								I_L $\xrightarrow{+}$ [1] \rightarrow [3] $+$
								[1] $\xrightarrow{<3.8 \text{ mA}}$ [3]
MIN								I_L $\xrightarrow{+}$ [1] \rightarrow [3] $+$
								[1] $\xrightarrow{<3.8 \text{ mA}}$ [3]
								[1] $\xrightarrow{I_L / <3,8 \text{ mA}}$ [3]
								[1] $\xrightarrow{<3.8 \text{ mA}}$ [3]

A0042586

Output signal

Output signal on power failure or in the event of damage to the sensor: $< 3.8 \text{ mA}$

Connectable load

- For relays with a minimum holding power or rated power:
 - $> 2.5 \text{ VA}$ at 253 V_{AC} (10 mA)
 - $> 0.5 \text{ VA}$ at 24 V_{AC} (20 mA)
- Relays with a lower holding power or rated power can be operated by means of an RC module connected in parallel.
- For relays with a maximum holding power or rated power:
 - $< 89 \text{ VA}$ at 253 V_{AC}
 - $< 8.4 \text{ VA}$ at 24 V_{AC}
- Voltage drop across FEI51: maximum 12 V
- Residual current with blocked thyristor: 3.8 mA
- Load switched directly into the power supply circuit via the thyristor.

DC PNP electronic insert
FEI52

Power supply

- Supply voltage: 10 to 55 V_{DC}
- Ripple:
 - maximum 1.7 V
 - 0 to 400 Hz
- Current consumption: $< 20 \text{ mA}$
- Power consumption without load: maximum 0.9 W
- Power consumption with full load (350 mA): 1.6 W
- Reverse polarity protection: yes
- Separation voltage: 3.7 kV
- Overvoltage category: II

Electrical connection

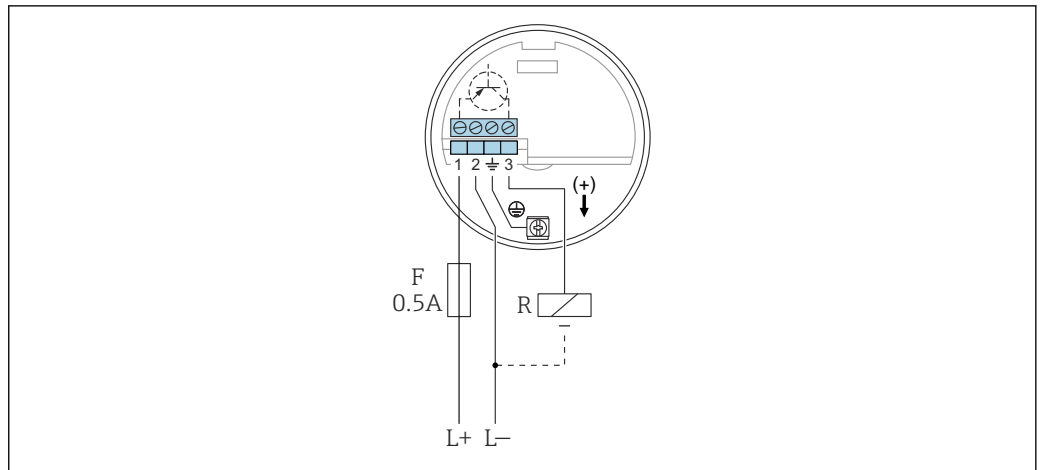

A0042388

- L+ Power input +
- L- Power input -
- F Fuse 0.5 A
- R External load: $I_{max} = 350 \text{ mA}$ $U_{max} = 55 \text{ V}_{DC}$

Preferably in conjunction with programmable logic controllers (PLC), DI modules in accordance with EN 61131-2.

Positive signal present at the switch output of the electronic system (PNP).

Output signal

		GN	GN	RD	GN	GN	YE	
MAX								L+ [1] — I_L —> [3] +
								[1] - - - I_R - - -> [3]
MIN								L+ [1] — I_L —> [3] +
								[1] - - - I_R - - -> [3]
								[1] - - - I_L / I_R - - -> [3]
								[1] - - - I_R - - -> [3]

A0042587

Signal on alarm

Output signal on power failure or in the event of device failure:
 $I_R < 100 \mu\text{A}$

Connectable load

- Load switched via transistor and separate PNP connection: maximum 55 V
- Load current: maximum 350 mA cyclical overload and short-circuit protection
- Residual current: < 100 μ A with transistor blocked
- Capacitance load:
 - maximum 0.5 μ F at 55 V
 - maximum 1 μ F at 24 V
- Residual voltage: < 3 V for transistor switched through

**3-wire electronic insert
FEI53****Power supply**

- Supply voltage: 14.5 V_{DC}
- Current consumption: < 15 mA
- Power consumption: maximum 230 mW
- Reverse polarity protection: yes
- Separation voltage: 0.5 kV

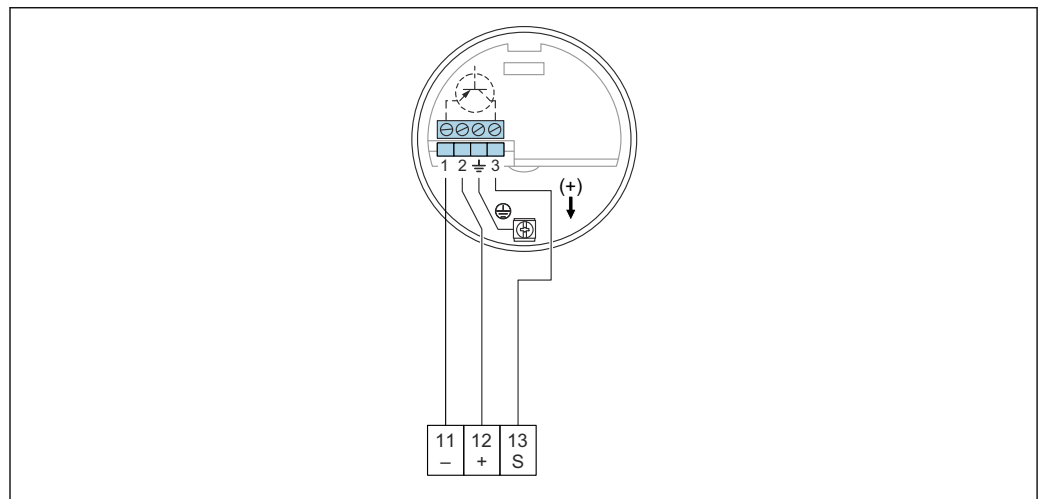
Electrical connection

A0042389

- 11 The negative terminal in Nivotester FTC325
 12 The positive terminal in Nivotester FTC325
 S Signal terminal in Nivotester FTC325

3 to 12 V signal.

For connecting to the switching unit, Nivotester FTC325 3-WIRE from Endress+Hauser.

Switching between minimum and maximum Safety in the Nivotester FTC325 3-WIRE.

Point level adjustment directly at the Nivotester.

Output signal

	GN	RD	
			3 ... 12 V
			3 ... 12 V
			<2.7 V

A0042588

Signal on alarm

Voltage at terminal 3 opposite terminal 1: < 2.7 V

Connectable load

- Floating relay contacts in the connected switching unit Nivotester FTC325 3-WIRE
- For the contact load capacity, refer to the technical data of the switching device

AC and DC with relay output electronic insert FEI54

Power supply

- Supply voltage:
 - 19 to 253 V_{AC} 50 to 60 Hz
 - 19 to 55 V_{DC}
- Power consumption: 1.6 W
- Reverse polarity protection: yes
- Separation voltage: 3.7 kV
- Overvoltage category: II

Electrical connection



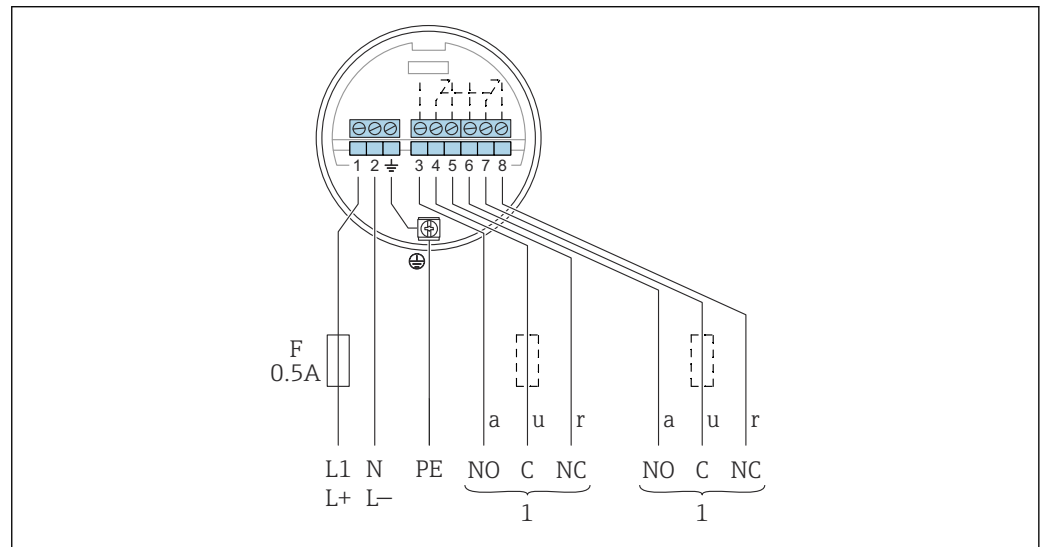















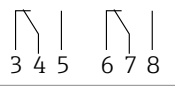







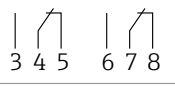







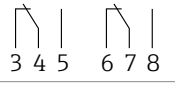







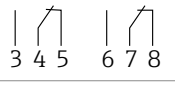



 Please note the different voltage ranges for AC and DC.



- F* Fuse 0.5 A
- L1* Phase (AC) terminal
- L+* The positive (DC) terminal
- N* Neutral (AC) terminal
- L-* The negative (DC) terminal
- PE* Grounding cable
- 1* Refer also to connectable load

When connecting an instrument with high inductance, provide a spark arrester to protect the relay contact. A fine-wire fuse (depending on the load connected) protects the relay contact on short-circuiting. Both relay contacts switch simultaneously.

Output signal

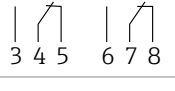
		GN	GN	RD	GN	GN	YE	
MAX								
								
MIN								
								
								
								

A0042528

Signal on alarm

Output signal on power failure or in the event of device failure: relay de-energized

Connectable load

- Loads switched via 2 floating changeover contacts (DPDT)
- maximum values (AC):
 - $I_{\max} = 6 \text{ A}$
 - $U_{\max} = 253 \text{ V}_{AC}$
 - $P_{\max} = 1500 \text{ VA}$ at $\cos\varphi = 1$
 - $P_{\max} = 750 \text{ VA}$ at $\cos\varphi > 0.7$
- maximum values (DC):
 - $I_{\max} = 6 \text{ A}$ at 30 V_{DC}
 - $I_{\max} = 0.2 \text{ A}$ at 125 V_{DC}
- The following applies when connecting a functional low-voltage circuit with double isolation as per IEC 1010:
 - sum of voltages of relay output and power supply maximum 300 V

SIL2 / SIL3 electronic insert
FEI55

Power supply

- Supply voltage: 11 to 36 V_{DC}
- Power consumption: < 600 mW
- Reverse polarity protection: yes
- Separation voltage: 0.5 kV

Electrical connection

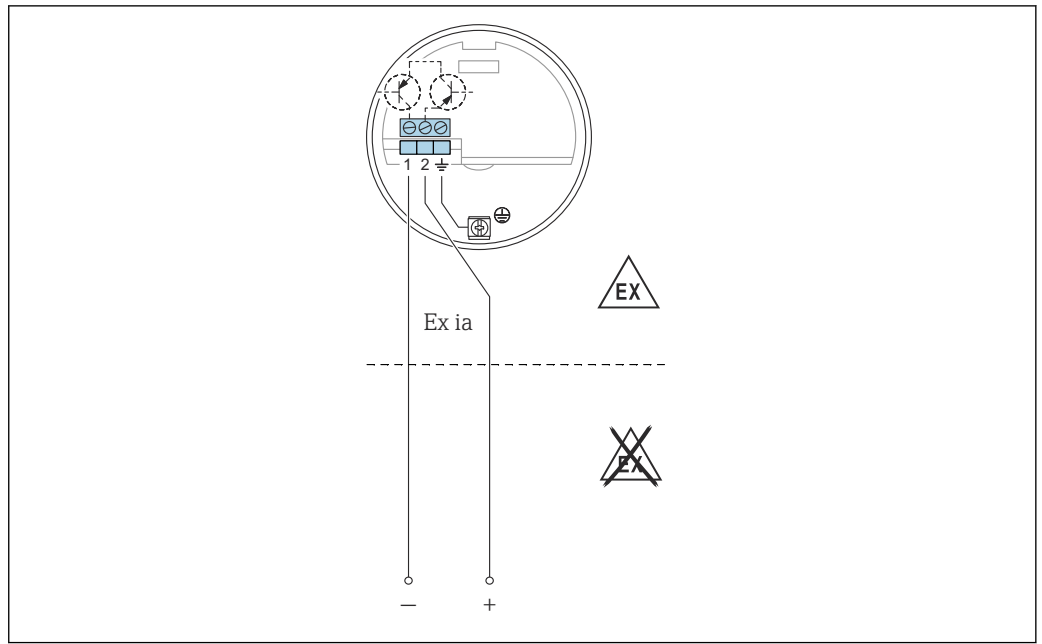

Connect the insert to programmable logic controllers (PLC), AI modules 4 to 20 mA in accordance with EN 61131-2.

The point level signal is sent via an output signal jump from 8 to 16 mA.

Output signal

		GN	GN	RD	GN	GN	YE	
MAX								+ 2 $\xrightarrow{\sim 16 \text{ mA}}$ 1
								+ 2 $\xrightarrow{\sim 8 \text{ mA}}$ 1
MIN								+ 2 $\xrightarrow{\sim 16 \text{ mA}}$ 1
								+ 2 $\xrightarrow{\sim 8 \text{ mA}}$ 1
								+ 2 $\xrightarrow{\sim 8/16 \text{ mA}}$ 1
								+ 2 $\xrightarrow{< 3.6 \text{ mA}}$ 1

Signal on alarm

Output signal on power failure or in the event of device failure: < 3.6 mA

Connectable load

- U:
 - 11 to 36 V_{DC} for non-hazardous area and Ex ia
 - 14.4 to 30 V_{DC} for Ex d
- I_{max} = 16 mA

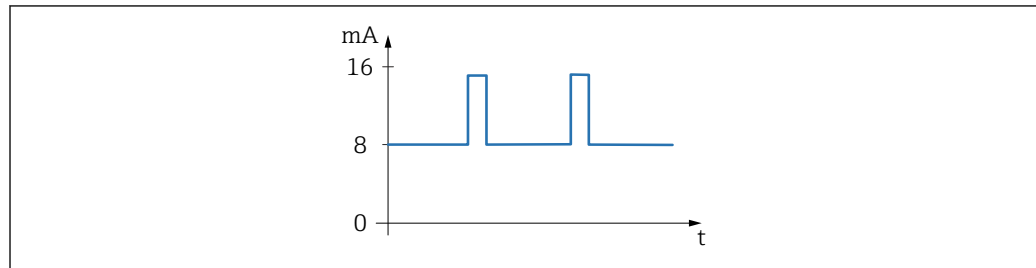
PFM electronic insert FEI57S Power supply

A0051934

21 PFM signal with frequency 17 to 185 Hz

- Supply voltage: 9.5 to 12.5 V_{DC}
- Power consumption: < 150 mW
- Reverse polarity protection: yes
- Separation voltage: 0.5 kV

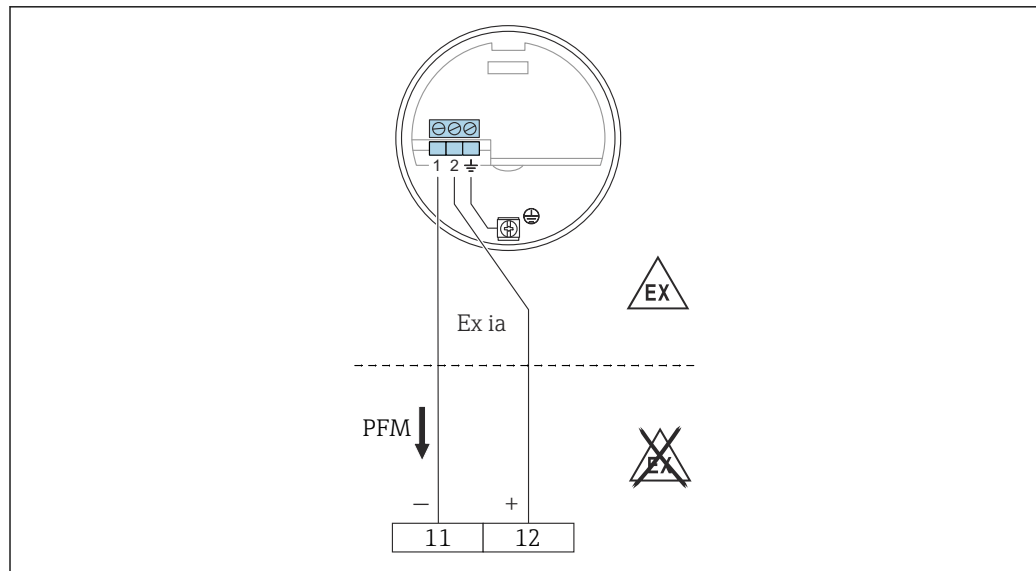
Electrical connection

A0050141

11 The negative terminal in Nivotester FTC325

12 The positive terminal in Nivotester FTC325

For connecting to switching unit Nivotester FTC325 from Endress+Hauser.

PFM signal 17 to 185 Hz.

Switching between minimum and maximum safety in the Nivotester.

Output signal

PFM 60 to 185 Hz.

Signal on alarm

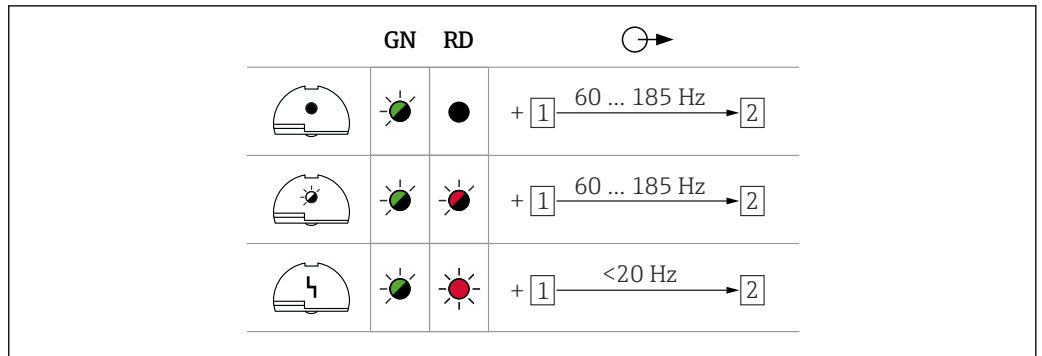

A0042589

Connectable load

- Floating relay contacts in the connected switching unit Nivotester: FTC325 PFM
- For the contact load capacity, refer to the technical data of the switching device.

NAMUR electronic insert FEI58

Power supply

- Power consumption:
 - < 6 mW at I < 1 mA
 - < 38 mW at I = 2.2 to 4 mA
- Interface connection data: IEC 60947-5-6

Electrical connection

-  In the case of Ex-d operation, the additional function can only be used if the housing is not exposed to an explosive atmosphere.

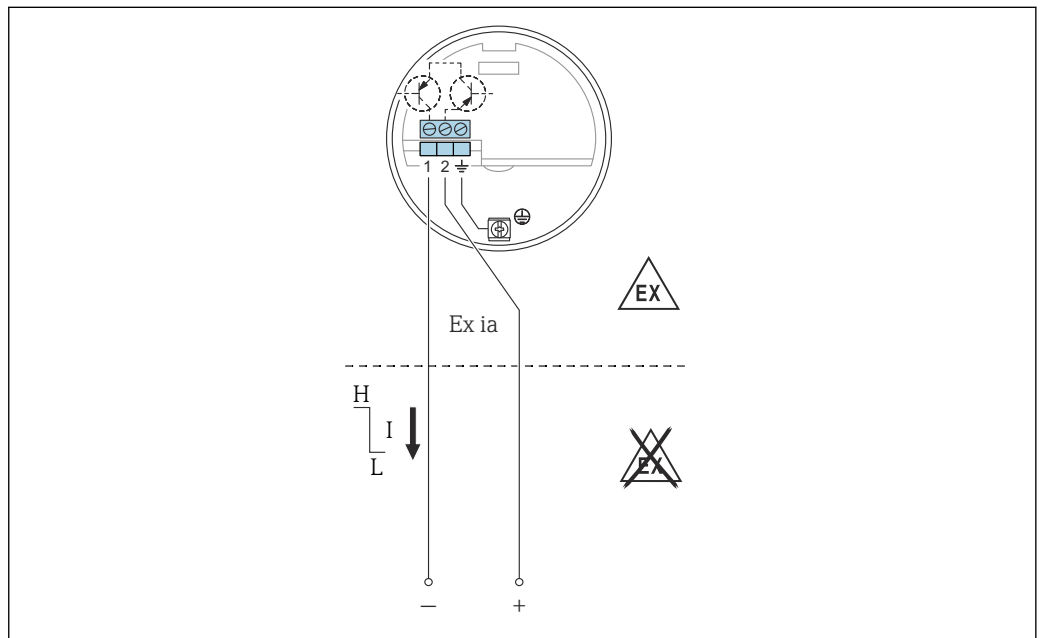

A0042393

 22 Terminals must be connected to isolating amplifier (NAMUR) IEC 60947-5-6

For connecting to isolating amplifiers as per NAMUR (IEC 60947-5-6), e.g. Nivotester FTL325N from Endress+Hauser. Change in output signal from high to low current in event of point level detection.













Additional function:

Test key on the electronic insert. Pressing the key interrupts the connection to the isolating amplifier.

Connection to Multiplexer:

Set 3 s as the cycle time at least.

Output signal

		GN	YE	⊖ →
MAX				+ 2 → 2.2 ... 3.5 mA → 1
				+ 2 → 0.6 ... 1.0 mA → 1
MIN				+ 2 → 2.2 ... 3.5 mA → 1
				+ 2 → 0.6 ... 1.0 mA → 1

A0042631

Signal on alarm

Output signal in the event of damage to the sensor: < 1.0 mA

Connectable load

- The technical data of the connected isolating amplifier as per IEC 60947-5-6 (NAMUR).
- Connection also to isolating amplifiers which have special safety circuits I > 3.0 mA.

Certificates and approvals

Current certificates and approvals for the product are available at www.endress.com on the relevant product page:

1. Select the product using the filters and search field.
2. Open the product page.
3. Select **Downloads**.

Other certificates and approvals for the product are available under <https://www.endress.com>-> Downloads.

Ordering information

Detailed ordering information is available from your nearest sales organization www.addresses.endress.com or in the Product Configurator at www.endress.com:

1. Select the product using the filters and search field.
2. Open the product page.
3. Select **Configuration**.



Product Configurator - the tool for individual product configuration

- Up-to-the-minute configuration data
- Depending on the device: Direct input of measuring point-specific information such as measuring range or operating language
- Automatic verification of exclusion criteria
- Automatic creation of the order code and its breakdown in PDF or Excel output format
- Ability to order directly in the Endress+Hauser Online Shop

Accessories

Protective cover **Protective cover for F13, F17 and F27 housing (without display)**
order number: 71040497

Protective cover for F16 housing
order number: 71127760

Seal set for stainless steel housing Seal set for stainless steel housing F15 with 5 sealing rings
Part number: 52028179

Surge arresters

HAW562



- For supply lines: BA00302K.
- For signal lines: BA00303K.

HAW569



- For signal lines in field housing: BA00304K.
- For signal or supply lines in field housing: BA00305K.

Technical information

Nivotester FTC325
TI00380F

Documentation



- For an overview of the scope of the associated Technical Documentation, refer to the following:
- *Device Viewer* (www.endress.com/deviceviewer): Enter the serial number from the nameplate
 - *Endress+Hauser Operations app*: Enter serial number from nameplate or scan matrix code on nameplate.

Document function

The following documentation may be available depending on the version ordered:

Document type	Purpose and content of the document
Technical Information (TI)	Planning aid for your device The document contains all the technical data on the device and provides an overview of the accessories and other products that can be ordered for the device.
Brief Operating Instructions (KA)	Guide that takes you quickly to the 1st measured value The Brief Operating Instructions contain all the essential information from incoming acceptance to initial commissioning.
Operating Instructions (BA)	Your reference document The Operating Instructions contain all the information that is required in the various phases of the life cycle of the device: from product identification, incoming acceptance and storage, to mounting, connection, operation and commissioning through to troubleshooting, maintenance and disposal.
Description of Device Parameters (GP)	Reference for your parameters The document provides a detailed explanation of each individual parameter. The description is aimed at those who work with the device over the entire life cycle and perform specific configurations.
Safety Instructions (XA)	Depending on the approval, safety instructions for electrical equipment in hazardous areas are also supplied with the device. The Safety Instructions are an integral part of the Operating Instructions.  Information on the Safety Instructions (XA) relevant to the device is provided on the nameplate.
Supplementary device-dependent documentation (SD/FY)	Always comply strictly with the instructions in the relevant supplementary documentation. The supplementary documentation is an integral part of the device documentation.





www.addresses.endress.com
