

Technical Information

Liquicap M

FTI51

Capacitance



Point level switch for liquids

Application

For liquids that tend to form build-up. Interface detection of different liquids. Two-point control (pump control) with just one process connection. Foam detection of conductive liquids.

- Process connections: flanges, threads, special hygienic process connections
- International explosion protection certificates, overfill prevention WHG, SIL, hygienic certificates, marine approval

Benefits

- Cost savings thanks to easy and fast commissioning as calibration takes place at the press of a button
- Reliable and safe measurement due to active build-up compensation
- Reliable and universal application thanks to wide range of certificates and approvals
- Short reaction time
- Material in contact with the process made of corrosion-resistant and FDA-listed materials
- Two-stage overvoltage protection
- No need for recalibration after replacing electronics

Table of contents

Document information	3	Mechanical construction	23
Document conventions	3	Housing	23
Function and system design	4	The extension height of housing with adapter	24
Measuring principle	4	Process connections	26
Function	5	Fully insulated rod probes	36
Interface	5	Fully insulated rod probes for hygiene applications	40
Foam detection	5	Partially insulated rod probes for a switch point with millimeter accuracy in conductive liquids	42
Measuring system	6	Weight	45
Electronic inserts	8	Technical data: probe	45
System integration via Fieldgate	9	Materials	45
Input	9	Operability	46
Measured variable	9	2-wire AC electronic insert FEI51	46
Measuring range	9	DC PNP electronic insert FEI52	47
Minimum probe length for nonconductive media < 1 µS/cm	9	3-wire electronic insert FEI53	49
Measuring condition	10	AC and DC with relay output electronic insert FEI54	50
Output	10	SIL2 / SIL3 electronic insert FEI55	51
Switch behavior	10	PFM electronic insert FEI57S	53
Switch-on behaviour	10	NAMUR electronic insert FEI58	54
Fail-safe mode	10	Certificates and approvals	55
Switching delay	11	Ordering information	56
Galvanic isolation	11	Accessories	56
Power supply	11	Protective cover	56
Electrical connection	11	Surge arresters	56
Connector	11	Weld-in adapter	56
Cable entry	12	Technical information	56
Performance characteristics	12	Documentation	56
Reference operating conditions	12	Document function	57
Switch-on behaviour	12		
Ambient temperature effect	12		
Installation	12		
Installation instructions	12		
Environment	17		
Ambient temperature range	17		
Storage and transport	17		
Climate class	17		
Vibration resistance	17		
Shock resistance	17		
Cleaning	17		
Degree of protection	17		
Electromagnetic compatibility (EMC)	18		
Process	18		
Process temperature range	18		
Process pressure limits	20		
Pressure and temperature derating	21		
Liquicap M operational range	22		

Document information

Document conventions

Safety symbols

DANGER

This symbol alerts you to a dangerous situation. Failure to avoid this situation will result in serious or fatal injury.

WARNING

This symbol alerts you to a dangerous situation. Failure to avoid this situation can result in serious or fatal injury.

CAUTION

This symbol alerts you to a dangerous situation. Failure to avoid this situation can result in minor or medium injury.

NOTICE

This symbol contains information on procedures and other facts which do not result in personal injury.

Electrical symbols



Alternating current



Direct current and alternating current



Direct current



Ground connection

A grounded terminal which, as far as the operator is concerned, is grounded via a grounding system.

Protective earth (PE)

Ground terminals that must be connected to ground prior to establishing any other connections.

The ground terminals are located on the interior and exterior of the device:

- Interior ground terminal: protective earth is connected to the mains supply.
- Exterior ground terminal: device is connected to the plant grounding system.

Tool symbols



Phillips head screwdriver



Flat blade screwdriver



Torx screwdriver



Allen key



Open-ended wrench

Symbols for certain types of information and graphics

Permitted

Procedures, processes or actions that are permitted

Preferred

Procedures, processes or actions that are preferred

Forbidden

Procedures, processes or actions that are forbidden

Tip

Indicates additional information



Reference to documentation



Reference to page



Reference to graphic



Notice or individual step to be observed

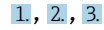

Series of steps



Result of a step



Help in the event of a problem



Visual inspection



Operation via operating tool



Write-protected parameter

1, 2, 3, ...

Item numbers

A, B, C, ...

Views



Hazardous area

Indicates the hazardous area



Safe area (non-hazardous area)

Indicates the non-hazardous area



Safety instructions

Observe the safety instructions contained in the associated Operating Instructions



Temperature resistance of the connection cables

Specifies the minimum value of the temperature resistance of the connection cables

Function and system design

Measuring principle

The principle of capacitance point level detection is based on the change in capacitance of the capacitor due to the probe being covered by liquid. The probe and container wall (conductive material) form an electric capacitor. When the probe is in air (1), a certain low initial capacitance is measured. When the container is filled, the capacitance of the capacitor increases the more the probe is covered (2), (3). The point level switch switches when the capacitance C_S specified during calibration is reached. In addition, a probe with inactive length ensures that the effects of medium buildup or condensate near the process connection are avoided. Active buildup compensation compensates influences resulting from buildup on the probe.



A ground tube is used as a counter electrode for containers made of non-conductive materials.

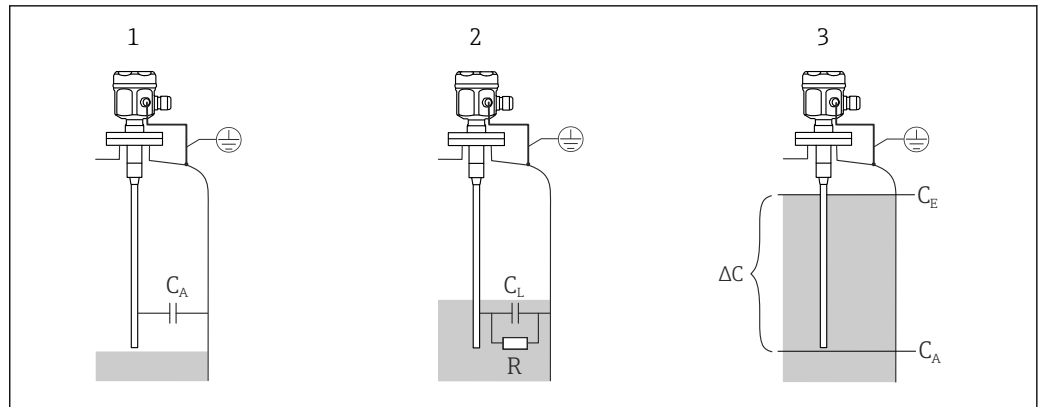

A0040662

1 Measuring principle of capacitance point level detection

- 1 The probe in the air
- 2 The probe covered by the liquid
- 3 The probe covered by the liquid (switching mode)
- R Conductivity of the liquid
- C Capacitance of the liquid
- C_A Initial capacitance when the probe is not covered
- C_S Switching capacitance
- ΔC Change in capacitance

Function

The selected electronic insert of the probe determines the change in capacitance on how much the probe is covered and thereby allows precise switching at the calibrated point level.

Interface

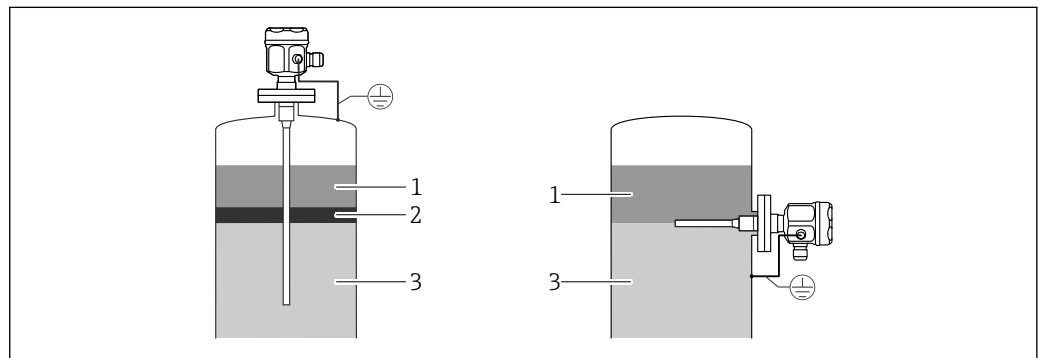

A0042605

2 The interface overview

- 1 Non-conductive medium $< 1 \mu S/cm$
- 2 Emulsion
- 3 Conductive medium $\ge 100 \mu S/cm$

A prior adjustment also ensures a certain and definite switch point even if the emulsion layer is of varying thickness.

Foam detection

 Use partially insulated probes.

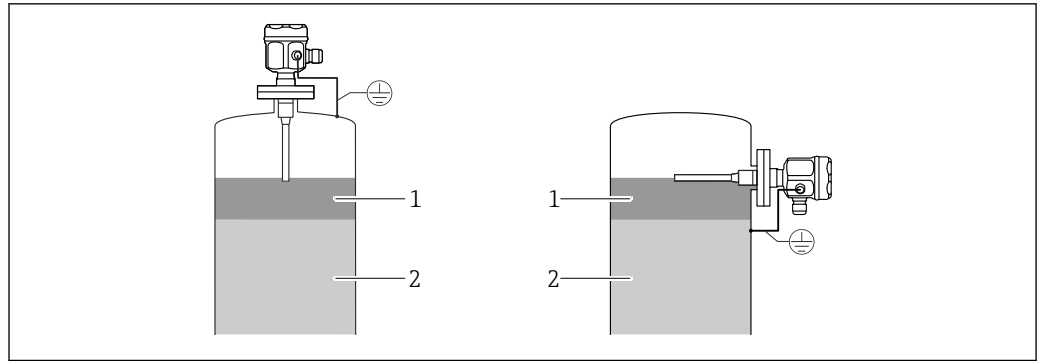

A0042606

3 Foam detection for conductive liquids

- 1 Foam
2 Liquid

Measuring system

i The type of the measuring system depends on the electronic insert selected.

Point level switch

The compact measuring system consists of:

- the Liquicap M FTI51 point level switch
- an electronic insert FEI51, FEI52 or FEI54

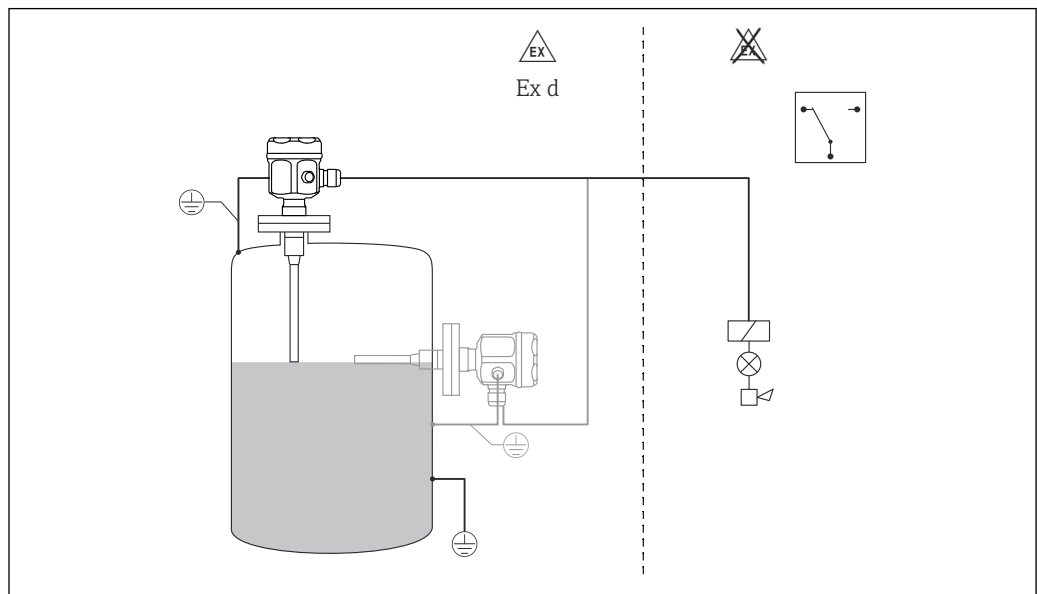

A0042608

4 Probe as a point level switch

Pump control (Δs)

i Only possible with a fully insulated probe.

The point level switch can also be used to control a pump, where the switch-on and switch-off point can be defined.

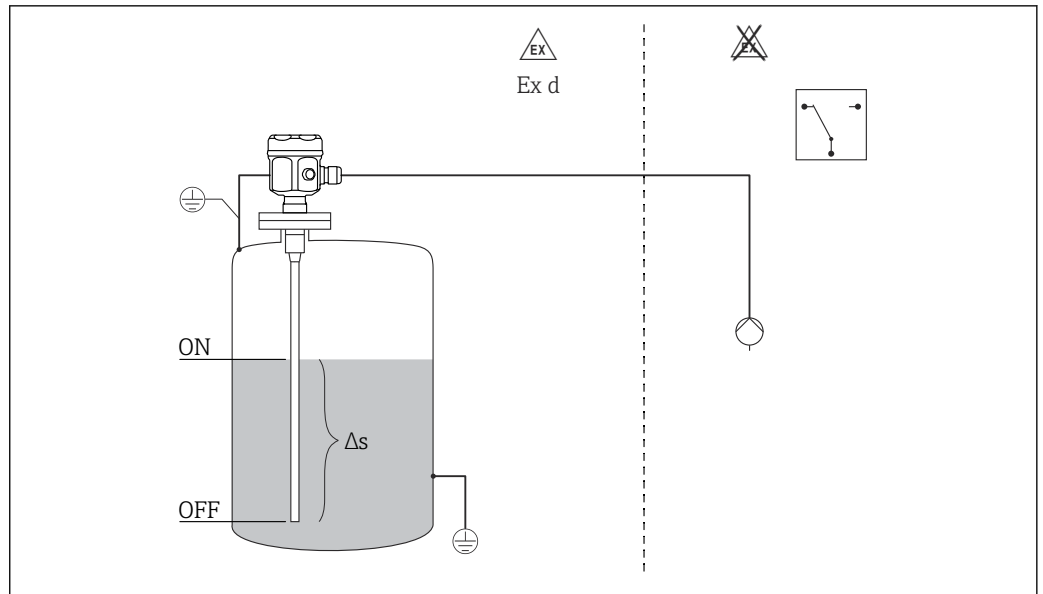

5 Probe as a two-point control switch

Δs Two-point control range

Point level switch and separate switching unit

Liquicap M FTI51 with electronic versions FEI53, FEI57S and FEI58 for connecting to a separate switching unit.

The complete measuring system consists of:

- the capacitance Liquicap M FTI51 point level switch
- an electronic insert FEI53, FEI57S and FEI58
- a transmitter power supply unit FTC325, FTL325N

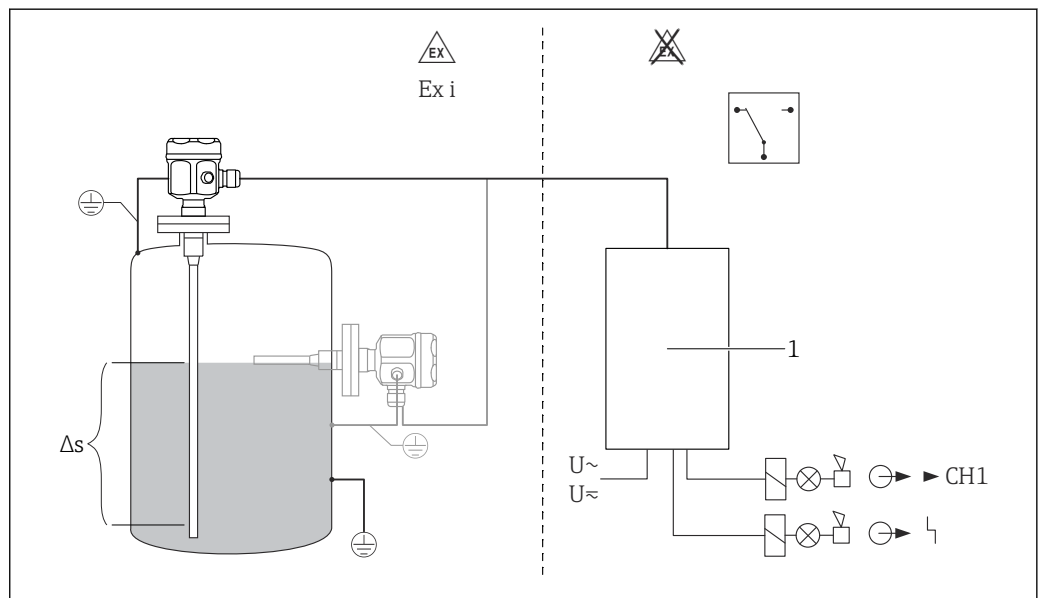

6 Probe as a point level switch

Δs Two-point control range. Only with FEI53

1 Transmitter power supply unit

Point level switch 8 to 16 mA

The complete measuring system consists of:

- the Liquicap M FTI51 point level switch
- the FEI55 electronic insert
- a transmitter power supply unit, e.g. RMA42

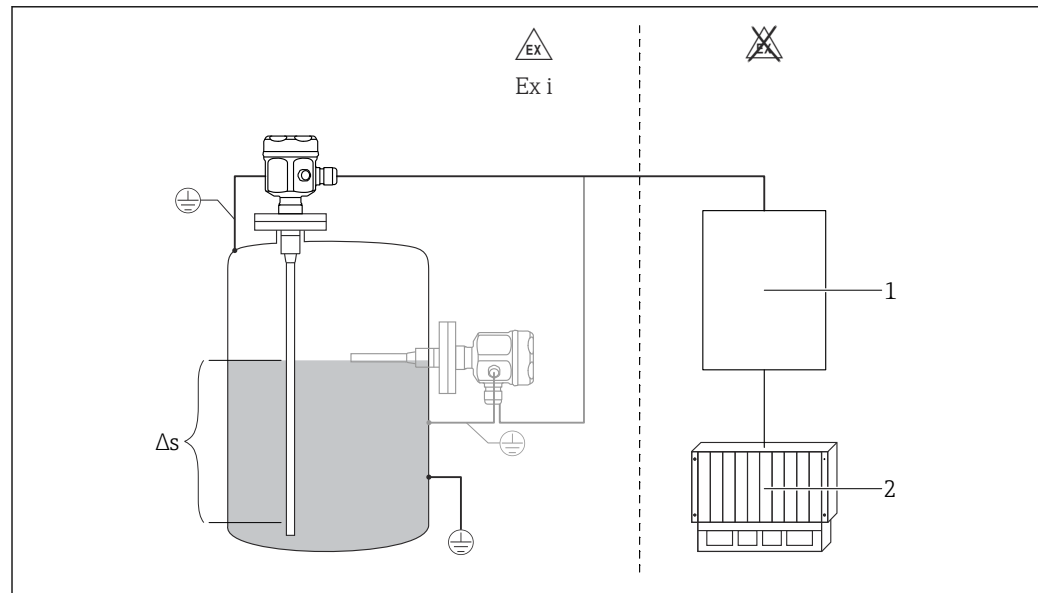

7 Probe as a point level switch 8 to 16 mA

Δs Two-point control range

1 Transmitter power supply unit

2 PLC

Electronic inserts

FEI51

Two-wire AC connection:

- load switched directly into the power supply circuit via the thyristor
- point level adjustment at the touch of a button

FEI52

3-wire direct current version:

- switch the load via the transistor (PNP) and separate supply voltage connection
- point level adjustment at the touch of a button

FEI53

3-wire direct current version with 3 to 16 V signal output:

- for separate switching unit, Nivotester FTC325 3-WIRE
- self-test from the switching unit without changing levels
- point level adjustment at the touch of a button

FEI54

Universal current version with relay output:

- switch the loads via 2 floating changeover contacts (DPDT)
- point level adjustment at the touch of a button

FEI55

Signal transmission 8 to 16 on two-wire cabling:

- SIL2 approval for the hardware
- SIL3 approval for the software
- for separate switching unit (e.g. RMA42)
- point level adjustment at the touch of a button

FEI57S

PFM signal transmission (current pulses are superimposed on the supply current):

- for separate switching unit with PFM signal transmission e.g. Nivotester FTC325 PFM
- self-test from the switching unit without changing levels
- point level adjustment at the touch of a button
- cyclical checking (function check) from the switching unit

FEI58 (NAMUR)

Signal transmission H-L edge 2.2 to 3.5 mA or 0.6 to 1.0 mA as per IEC 60947-5-6 on two-wire cable:

- for a separate switching unit (e.g. Nivotester FTL325N)
- point level adjustment at the touch of a button
- connection cables and slaves tested at the touch of a button

System integration via Fieldgate

Vendor managed inventory

The remote interrogation of tank or silo levels via Fieldgate enables suppliers of raw materials to gather information about the current inventories of their regular customers at any time and, for example, to take this into account in their own production planning. The Fieldgate monitors the configured point levels and automatically triggers the next order as required. Here, the range of possibilities ranges from simple requisitioning by e-mail through to fully automatic order processing by incorporating XML data into the planning systems on both sides.

Remote maintenance of measuring systems

Not only does Fieldgate transmit the current measured values, it also alerts the standby personnel responsible by e-mail or SMS as required. Fieldgate forwards the information transparently. In this way, all options of the operating software in question are available remotely. By using remote diagnosis and remote configuration some onsite service operations can be avoided and all others can at least be planned and prepared better.

Input

Measured variable

Measurement of change in capacitance between probe rod and tank wall or ground tube and depends on the level of a liquid.

Probe covered = high capacitance

Probe not covered = low capacitance

Measuring range

Measuring frequency

500 Hz

Span

- $\Delta C = 5$ to 1 600 pF
- FEI58: $\Delta C = 5$ to 500 pF

Final capacitance

$C_E =$ maximum 1 600 pF

Adjustable initial capacitance

- range 1 - factory setting
 $C_A = 5$ to 500 pF
- range 2 - not available with FEI58
 $C_A = 5$ to 1 600 pF

The minimum change in capacitance for point level detection

≥ 5 pF

Minimum probe length for nonconductive media < 1 μ S/cm

The minimum probe length can be calculated using the formula:

$$l_{\min} = \frac{\Delta C_{\min}}{C_s \cdot (\epsilon_r - 1)}$$

A0040204

l_{\min}	minimum probe length
ΔC_{\min}	5 pF

C_s	probe capacitance in air
ϵ_r	relative dielectric constant, e.g. for dried grain = 3.0

Measuring condition

- i** ■ When installing in a nozzle, use inactive length L3.
- Probes with active buildup compensation must be used for high-viscosity liquids that tend to form buildup.
- Fully insulated rod probes must be used for pump control (ΔS operation).
The switch-on and switch-off points are determined by the empty and full calibration.
The maximum length depends on the probe used. A $\varnothing 16$ mm (0.63 in) rod generates a capacitance of 380 pF/m (114 pF/ft) in a conductive liquid.
With a maximum span of 1 600 pF, this gives 1 600 pF/380 pF per meter = 4 m (13 ft) of total length.
- Use a ground tube for non-conductive media.

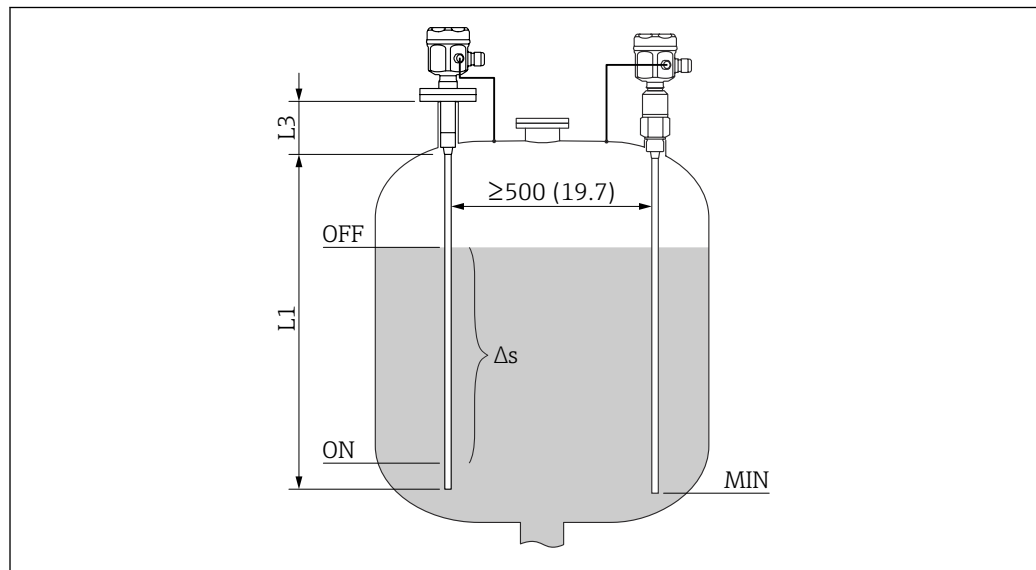

8 *Measuring condition. Unit of measurement mm (in)*

L1 Measuring range

L3 Inactive length

ΔS Two-points control range

The 0 % and 100 % calibration can be inverted.

Output

Switch behavior

Binary or ΔS operation.

- i** The pump control is not possible with FEI58.

Switch-on behaviour

When the power supply is switched on, the switching status of the outputs corresponds to the signal on the alarm.

The correct switch condition is reached after a maximum of 3 s.

Fail-safe mode

Minimum and maximum quiescent current safety can be switched at the electronic insert ¹⁾.

1) For FEI53 and FEI57S only on the associated Nivotester: FTC325.

MIN

Minimum safety: the output switches safety-oriented when the probe is uncovered ²⁾ (signal on alarm).

MAX

Maximum safety: the output switches safety-oriented when the probe is covered ³⁾ (signal on alarm).

Switching delay

FEI51, FEI52, FEI54, FEI55

Can be adjusted incrementally at the electronic insert: 0.3 to 10 s.

FEI53, FEI57S

Depends on the connected Nivotester (transmitter): FTC325.

FEI58

Can be adjusted alternately at the electronic insert: 1 s or 5 s

Galvanic isolation

FEI51 and FEI52

between the probe and power supply

FEI54

between the probe, power supply and load

FEI53, FEI55, FEI57S and FEI58

see connected switching device ⁴⁾

Power supply

Electrical connection

Depending on explosion protection, the connection compartment is available in the following variants:

Standard protection, Ex ia protection

- polyester housing F16
- stainless steel housing F15
- aluminum housing F17
- aluminum housing F13 with gas-tight process seal
- stainless steel housing F27 with gas-tight process seal
- aluminum housing T13 with a separate connection compartment

Ex d protection, Gas-tight process seal

- aluminum housing F13 with gas-tight process seal
- stainless steel housing F27 with gas-tight process seal
- aluminum housing T13 with a separate connection compartment

Connector

For the version with a connector M12, the housing does not have to be opened for connecting the signal line.

PIN assignment for M12 connector

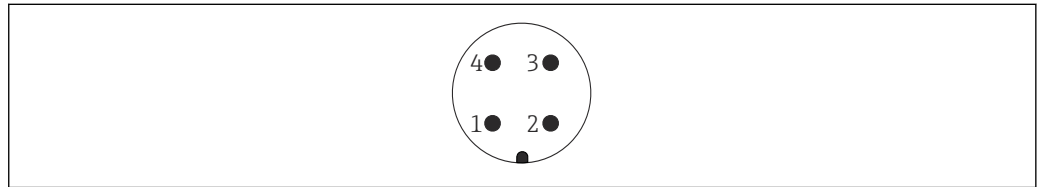

 9 M12 connector with 2-wire-electronic insert FEI55, FEI57, FEI58, FEI57C

- 1 Positive potential
- 2 Not used
- 3 Negative potential
- 4 Ground

A0011175

2) E.g. for dry running protection and pump protection.
 3) E.g. for use with overflow protection.
 4) Functional galvanic isolation in the electronic insert.

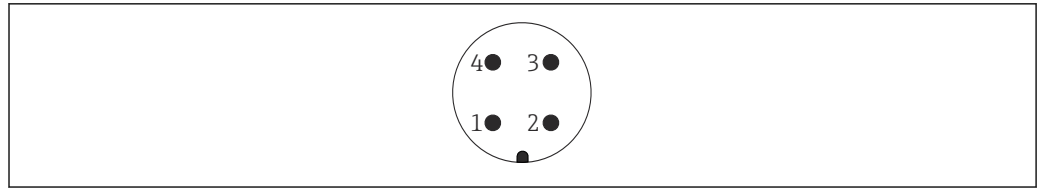

A0011175

10 M12 connector with 3-wire-electronic insert FEI52, FEI53

- 1 Positive potential
- 2 Not used
- 3 Negative potential
- 4 External load / signal

Cable entry

Cable gland

M20x1.5 for Ex d only cable entry M20
Two cable glands are included in scope of delivery.

Cable entry

- G $\frac{1}{2}$
- NPT $\frac{1}{2}$
- NPT $\frac{3}{4}$
- M20 thread

Performance characteristics

Reference operating conditions

Room temperature: 20 °C (68 °F) \pm 5 °C (\pm 8 °F)

Span:

- FEI51, FEI52, FEI53, FEI54, FEI55, FEI57S
 $\Delta C = 5$ to 1 600 pF
- FEI58 (NAMUR)
 $\Delta C = 5$ to 500 pF

Switch-on behaviour

When the power supply is switched on, the switching status of the outputs corresponds to the signal on the alarm.

The correct switch condition is reached after a maximum of 3 s.

Ambient temperature effect

Electronic insert

< 0.06 % per 10 K related to the full-scale value

Separate housing

capacitance change of connecting cable per meter 0.15 pF per 10 K

Installation

Installation instructions

Mounting the sensor

The Liquicap M FTI51 can be installed from the top or the bottom or from the side.



Make sure that:

- the probe is not installed in the area of the filling curtain
- the probe is not in contact with the container wall
- the distance from the container floor is \geq 10 mm (0.39 in)
- multiple probes are mounted next to each other at the minimum distance between the probes of 500 mm (19.7 in)
- the probe is at a sufficient distance from the agitator if using the probe in agitator tanks
- the rod probes with a ground tube are used in the event of severe lateral load

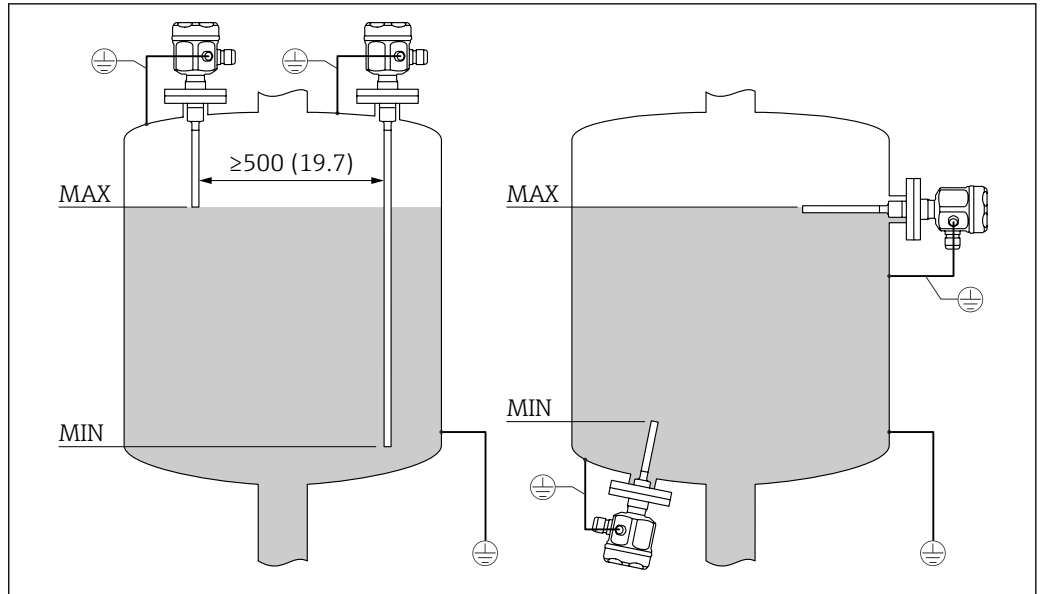

A0042377

11 Mounting the sensor in electrically conductive tanks. Unit of measurement mm (in)

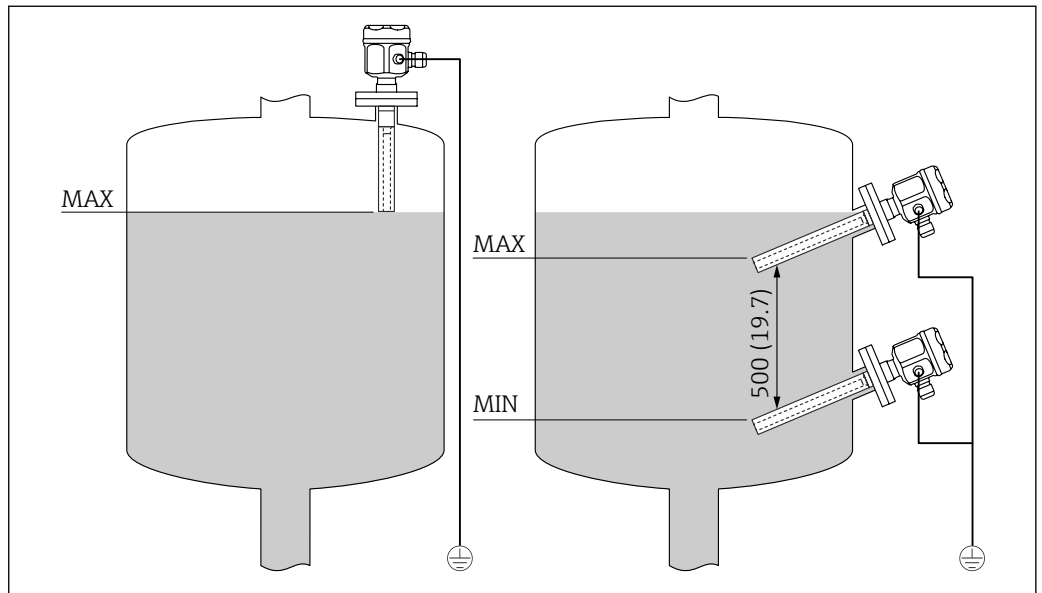



A0042378

12 Mounting the sensor in nonconductive tanks. Unit of measurement mm (in)

Support with marine approval (GL)

Conductive or non-conductive support can be provided for fully insulated rod probes. Partially insulated rod probes may only be supported with insulation at the uninsulated end of the probe.

i Rod probes with a diameter of 10 mm (0.39 in) and 16 mm (0.63 in), and a length ≥ 1 m (3.3 ft) must be supported, see →  13,  14

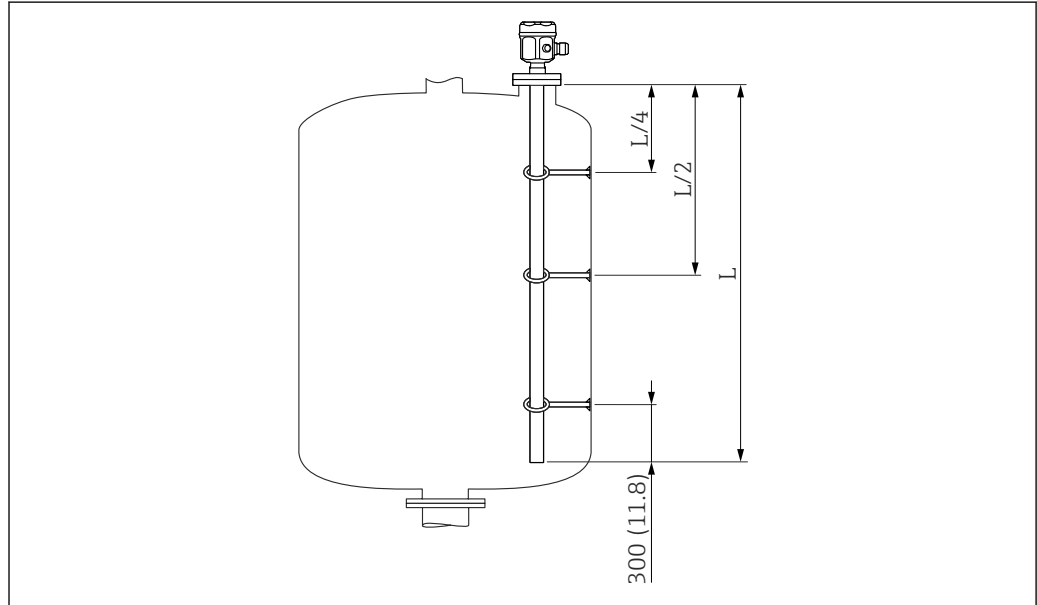

 13 Rod support overview. Unit of measurement mm (in)

$L/4$ $\frac{1}{4}$ probe length

$L/2$ $\frac{1}{2}$ probe length

L Active probe length

Example of calculating distances

- probe length $L = 2$ m (6.6 ft)
 - $L/4 = 500$ mm (19.7 in)
 - $L/2 = 1$ m (3.3 ft)
- Measured from the end of the probe rod = 300 mm (11.8 in).

Probe with separate housing

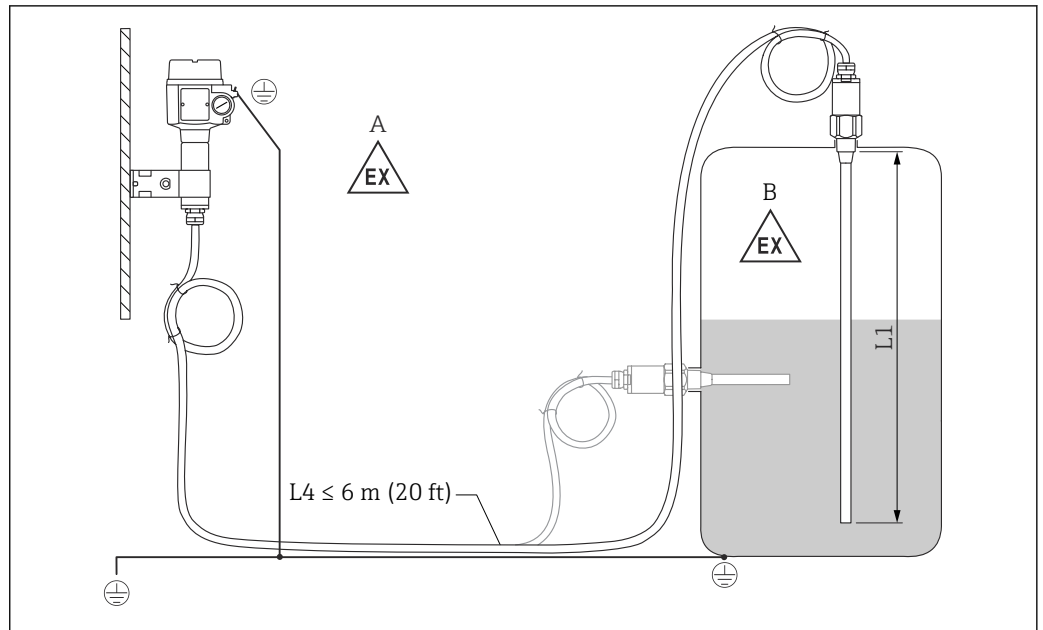

14 Connection of the probe and separate housing. Unit of measurement mm (in)

- A Explosive zone 1
 B Explosive zone 0
 L1 Rod length: max. 4 m (13 ft)
 L4 Cable length

The maximum cable length L_4 and rod length L_1 cannot exceed 10 m (33 ft).

i The maximum cable length between the probe and separate housing is 6 m (20 ft). The required cable length must be indicated in the ordering process of a Liquicap M with separate housing.

If the cable connection has to be shortened or led through a wall, then it must be separated from the process connection.

Extension heights: separate housing

- i** The cable has:
- a minimum bending radius of $r \geq 100 \text{ mm (3.94 in)}$
 - $\varnothing 10.5 \text{ mm (0.14 in)}$
 - outer jacket made of silicone, notch resistance

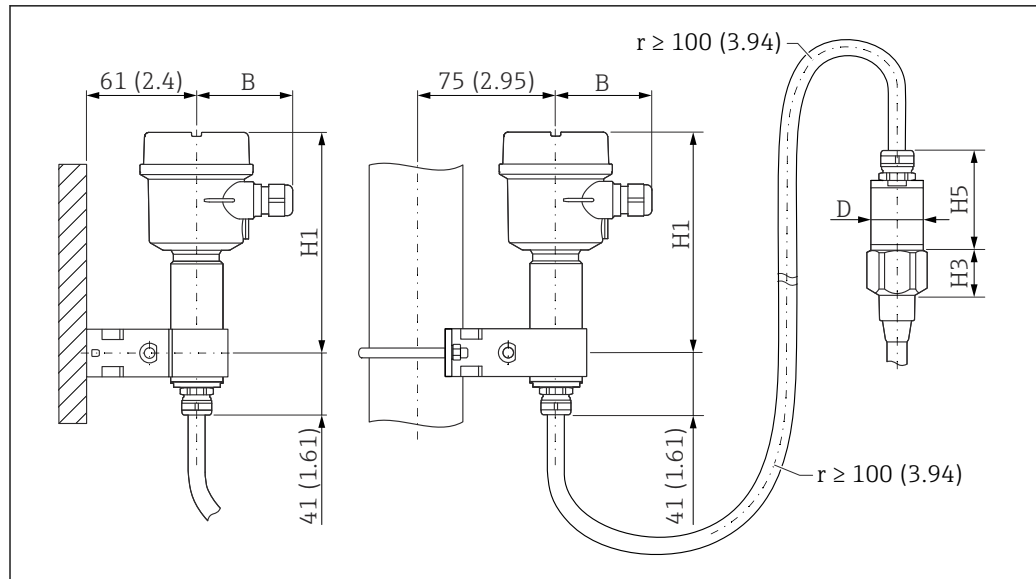

15 Housing side: wall mounting, pipe mounting, and sensor side. Unit of measurement mm (in)

Values of parameters⁵⁾:

Polyester housing (F16)

- B: 76 mm (2.99 in)
- H1: 172 mm (6.77 in)

Stainless steel housing (F15)

- B: 64 mm (2.52 in)
- H1: 166 mm (6.54 in)

Aluminum housing (F17)

- B: 65 mm (2.56 in)
- H1: 177 mm (6.97 in)

D and H5 parameter value

- Probes $\varnothing 10$ mm (0.39 in) rod:
 - D: 38 mm (1.5 in)
 - H5: 66 mm (2.6 in)
- Probes $\varnothing 16$ mm (0.63 in) rod, without fully insulated inactive length and threads G $\frac{1}{2}$ ", G $\frac{3}{4}$ ", G1", NPT $\frac{1}{2}$ ", NPT $\frac{3}{4}$ ", NPT1", Clamp 1", Clamp 1 $\frac{1}{2}$ ", Universal $\varnothing 44$ mm (1.73 in), flange < DN50, ANSI 2", 10K50:
 - D: 38 mm (1.5 in)
 - H5: 66 mm (2.6 in)
- Probes $\varnothing 16$ mm (0.63 in) rod, without fully insulated inactive length and threads: G1 $\frac{1}{2}$ ", NPT1 $\frac{1}{2}$ ", Clamp 2", DIN 11851, flange \geq DN50, ANSI 2", 10K50:
 - D: 50 mm (1.97 in)
 - H5: 89 mm (3.5 in)
- Probes $\varnothing 22$ mm (0.87 in) rod, with fully insulated inactive length:
 - D: 38 mm (1.5 in)
 - H5: 89 mm (3.5 in)

H3 parameter value

H3 is the height of the cone head. The height H3 depends on the type of process connection.

Wall bracket

- i
 - The wall bracket is a part of the scope of delivery.
 - To use the wall bracket as a drill template, the wall bracket must be first screwed to the separate housing.
 - The distance between the holes is reduced by screwing it to the separate housing.

5) See parameters on the drawings.

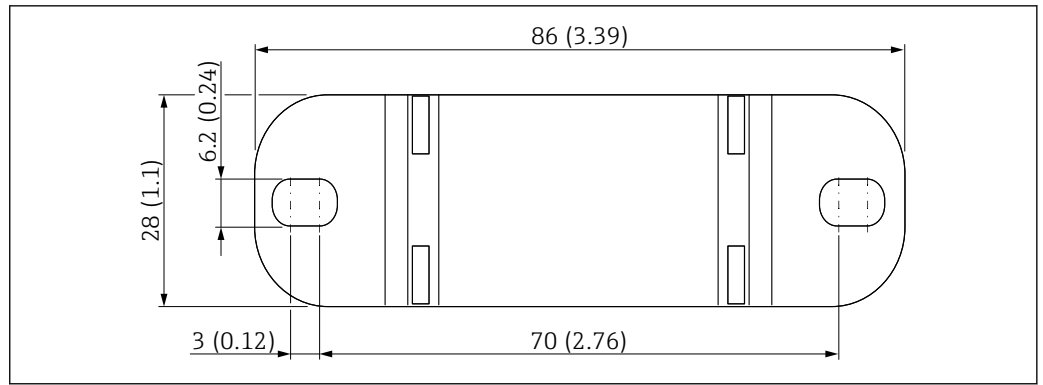

16 Wall bracket overview. Unit of measurement mm (in)

A0033881

Environment

Ambient temperature range	<ul style="list-style-type: none"> ▪ F16 housing: -40 to +70 °C (-40 to +158 °F) ▪ remaining housing: -50 to +70 °C (-58 to +158 °F) ▪ observe derating ▪ use a protective cover, when operating outdoors
Storage and transport	For storage and transportation, pack the device to protect it against impact. The original packing offers the best protection for this. The permitted storage temperature is -50 to +85 °C (-58 to +185 °F).
Climate class	DIN EN 60068-2-38/IEC 68-2-38: Z/AD check
Vibration resistance	DIN EN 60068-2-64/IEC 68-2-64: 20 to 2 000 Hz, 0.01 g ² /Hz
Shock resistance	DIN EN 60068-2-27/IEC 68-2-27: 30 g acceleration
Cleaning	<p>Housing</p> <p>Make sure that the cleaning agent used does not corrode the housing surface or the seals.</p> <p>Probe</p> <p>Depending on the application, buildup (contamination and soiling) can form on the probe rod. A high degree of material buildup can affect the measurement result. If the medium tends to create a high degree of buildup, regular cleaning is recommended. When cleaning, it is important to make sure that the insulation of the probe rod is not damaged. Make sure the material is resistant to used cleaning agent.</p>
Degree of protection	<p> All protection degree regarding EN60529.</p> <p>Type4X protection degree regarding NEMA250.</p> <p>Polyester housing F16</p> <p>Protection degree:</p> <ul style="list-style-type: none"> ▪ IP66 ▪ IP67 ▪ Type4X <p>Stainless steel housing F15</p> <p>Protection degree:</p> <ul style="list-style-type: none"> ▪ IP66 ▪ IP67 ▪ Type4X

Aluminum housing F17

Protection degree:

- IP66
- IP67
- Type4X

Aluminum housing F13 with gas-tight process seal

Protection degree:

- IP66
- IP68 ⁶⁾
- Type4X

Stainless steel housing F27 with gas-tight process seal

Protection degree:

- IP66
- IP67
- IP68 ⁶⁾
- Type4X

Aluminum housing T13 with gas-tight process seal and separate connection compartment (Ex d)

Protection degree:

- IP66
- IP68 ⁶⁾
- Type4X

Separate housing

Protection degree:

- IP66
- IP68 ⁶⁾
- Type4X

Electromagnetic compatibility (EMC)

Interference emission to EN 61326, Electrical Equipment Class B. Interference immunity to EN 61326, Annex A (Industrial) and NAMUR Recommendation NE 21 (EMC).

A standard commercial instrument cable can be used.

Process

Process temperature range

The following diagrams apply for:

- insulation
 - PTFE
 - PFA
- standard applications outside hazardous areas



The temperature is restricted to $T_a -40\text{ °C}$ (-40 °F) when the polyester housing F16 is used or if additional option B is selected: free from paint-wetting impairment substances, only FTI51.

6) Only with M20 cable entry or G½ thread.

Probe with compact housing

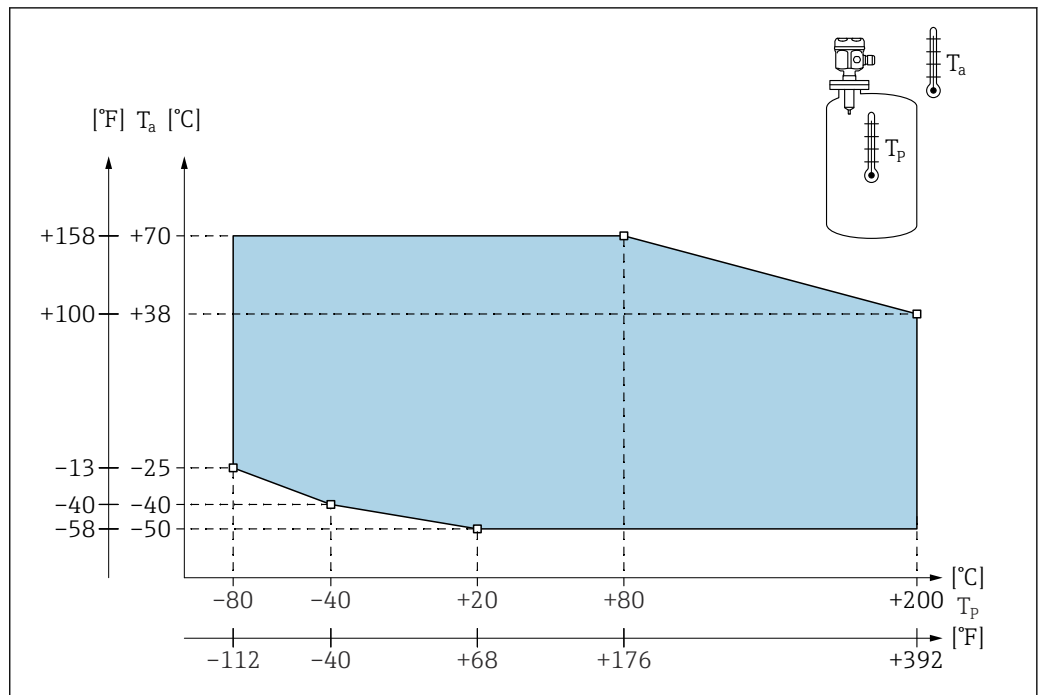

17 Process pressure range diagram: probe with compact housing

T_a Ambient temperature
 T_p Process temperature

Probe with separate housing

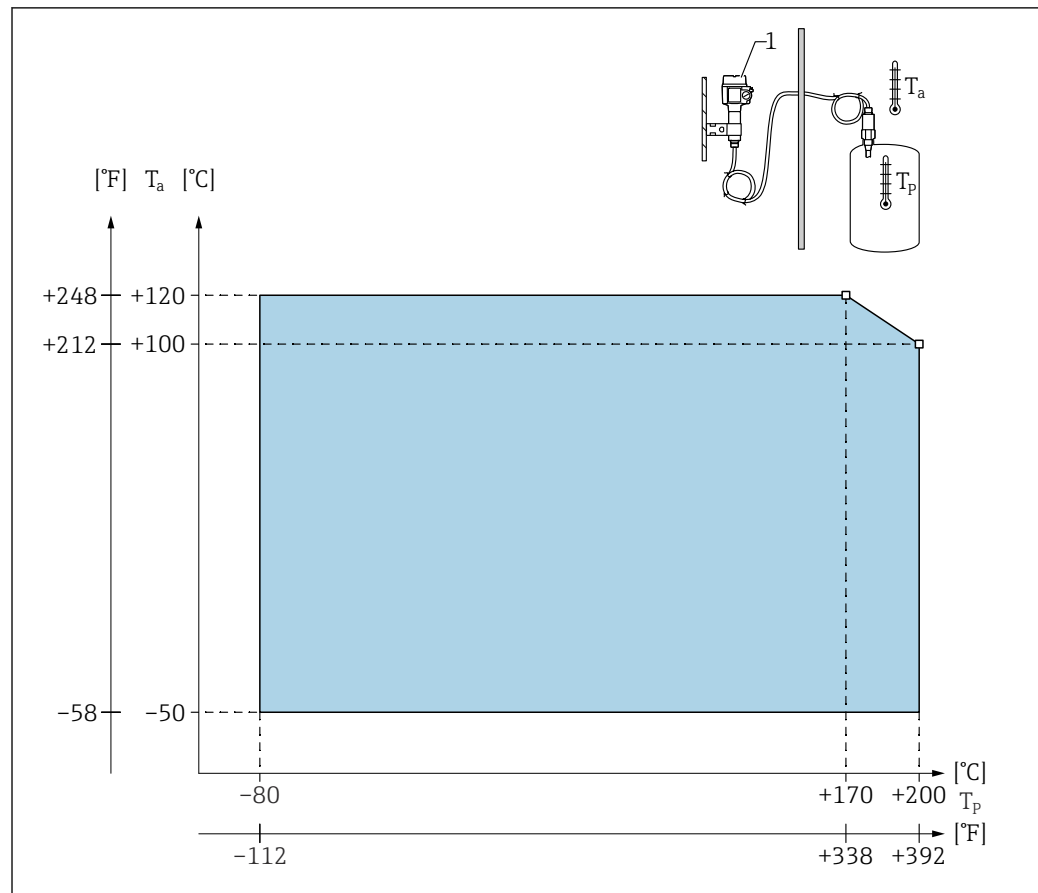

A0043639

18 Process pressure range diagram: probe with separate housing

T_a Ambient temperature

T_p Process temperature

1 The permitted ambient temperature at the separate housing is the same as indicated for the compact housing.

Influence of process temperature

Error in case of fully insulated probes typically 0.13 %/K related to the full-scale value.

Process pressure limits



The process pressure limits depends on process connections.

See also chapter "Process connections" → 26

Probe Ø10 mm (0.39 in) including insulation

-1 to 25 bar (-14.5 to 362.5 psi)

Probe Ø16 mm (0.63 in) including insulation

- -1 to 100 bar (-14.5 to 1450 psi)
- in regards to an inactive length, the maximum permitted process pressure is 63 bar (913.5 psi)
- for CRN approval and inactive length: the maximum permitted process pressure is 32 bar (464 psi)

Probe Ø22 mm (0.87 in) including insulation

-1 to 50 bar (-14.5 to 725 psi)

Refer to the following standards for the pressure values permitted at higher temperatures:

- EN 1092-1: 2005 Table, Appendix G2
 With regard to its resistance and temperature property, the material 1.4435 is identical to 1.4404 (AISI 316L) which is grouped under 13E0 in EN 1092-1 Tab. 18. The chemical composition of the two materials can be identical.
- ASME B 16.5a - 1998 Tab. 2-2.2 F316
- ASME B 16.5a - 1998 Tab. 2.3.8 N10276
- JIS B 2220

The lowest value from the derating curves of the device and the selected flange applies.

Pressure and temperature derating

For process connections 1/2", 3/4", 1", flanges <DN50, <ANSI 2", <JIS 10K (Ø 10 mm (0.39 in) rod) and process connections 3/4", 1", flanges <DN50, <ANSI 2", <JIS 10K (Ø 16 mm (0.63 in) rod)

Rod insulation: PTFE, PFA

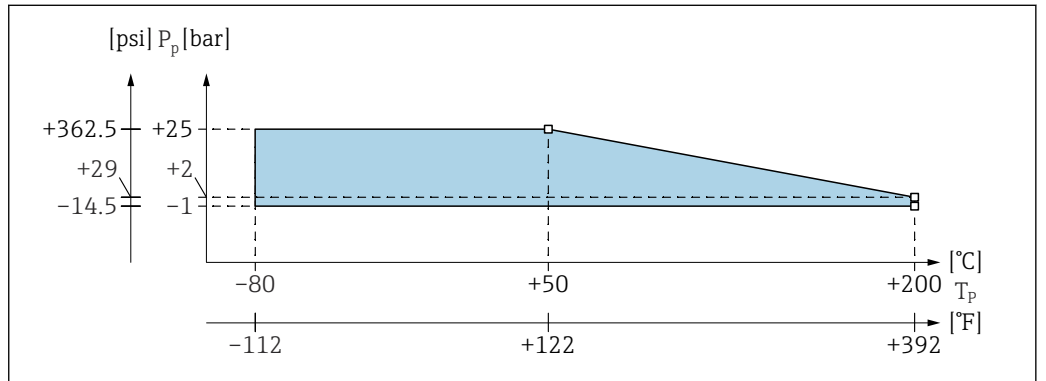

P_p Process pressure
 T_p Process temperature

For process connections 1 1/2", flanges ≥DN50, ≥ANSI 2", ≥JIS 10K (Ø 16 mm (0.63 in) rod)

Rod insulation: PTFE, PFA

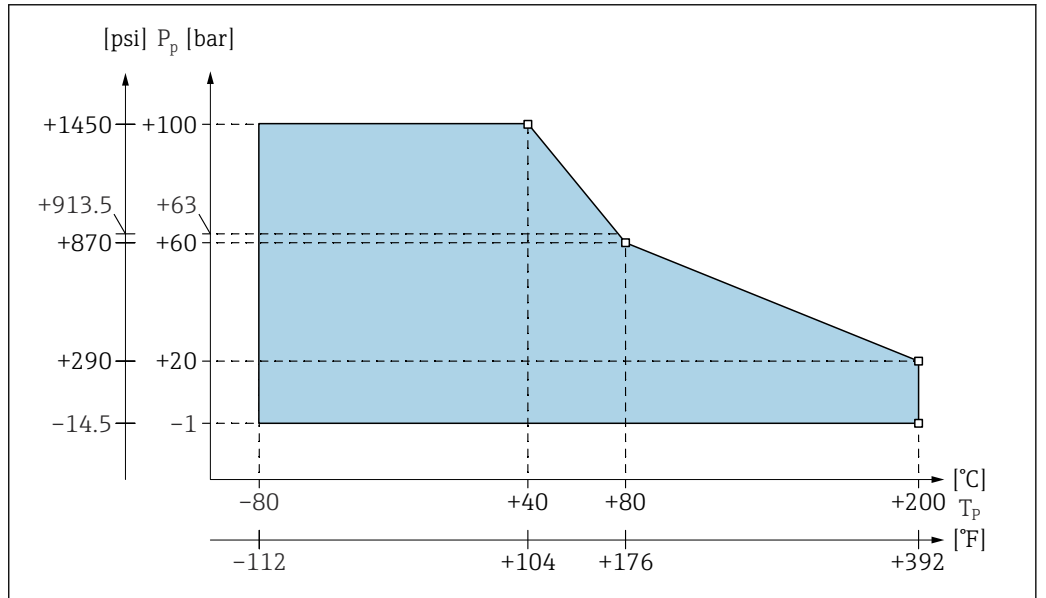

19 Process pressure and temperature derating diagram

P_p Process pressure
 T_p Process temperature
 63 Process pressure for probes with an inactive length

With a fully insulated inactive length (22 mm (0.87 in)) rod

Rod insulation: PTFE, PFA

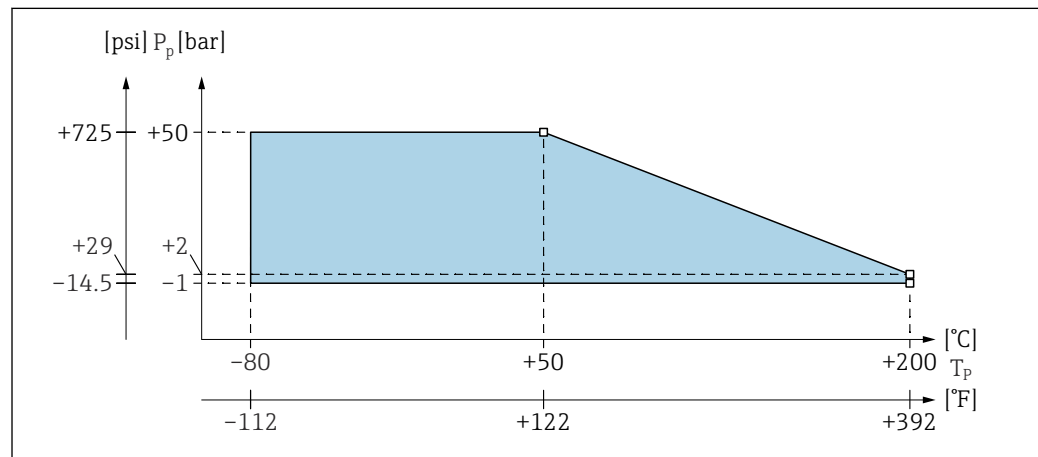

A0043642

20 Process pressure and temperature derating diagram

P_p Process pressure

T_p Process temperature

Liquicap M operational range

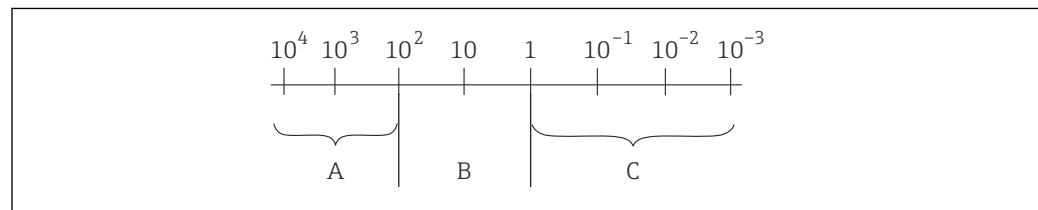

A0040690

21 The probe operational range. Unit of measurement: $\mu\text{S}/\text{cm}$

1 Factory calibration 0 to 100 %

2 Factory calibration 0 %

A The measuring accuracy is independent of the conductivity and dielectric constant value.

B The measuring accuracy depends on the dielectric constant value and the conductivity of the medium. Measurement not recommendable, select therefore a different measurement principle.

C The measuring accuracy depends on the dielectric constant value.

Typical dielectric constant (DC) values:

- air: 1
- vacuum: 1
- general liquified gases: 1.2 ... 1.7
- gasoline: 1.9
- diesel fuel: 2.1
- cyclohexane: 2 ... 4
- general oils: 2 ... 4
- methyl ether: 5
- butanol: 11
- ammonia: 21
- latex: 24
- ethanol: 25
- caustic soda: 22 ... 26
- acetone: 20
- glycerine: 37
- water: 81

 Further information and dielectric constants (DC values) in the Download Area of the Endress+Hauser web site:

- Endress+Hauser DC manual (CP01076F)
- Endress+Hauser "DC Values App" on Android and iOS

Mechanical construction

Housing

Polyester housing F16

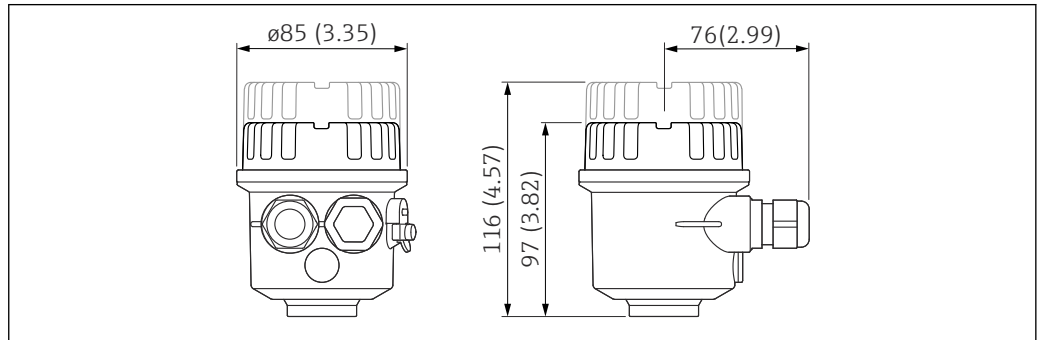

A0040691

Unit of measurement mm (in)

Stainless steel housing F15

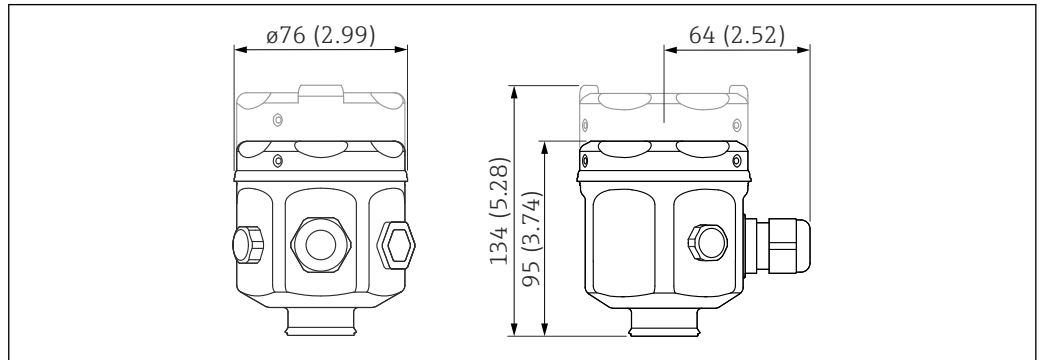

A0040692

Unit of measurement mm (in)

Stainless steel housing F17

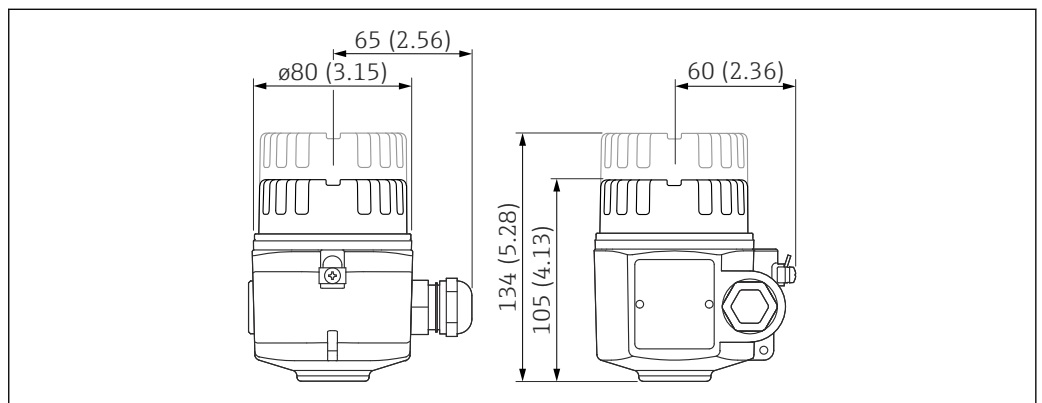

A0040693

Unit of measurement mm (in)

Aluminum housing F13

With the gas-tight process seal.

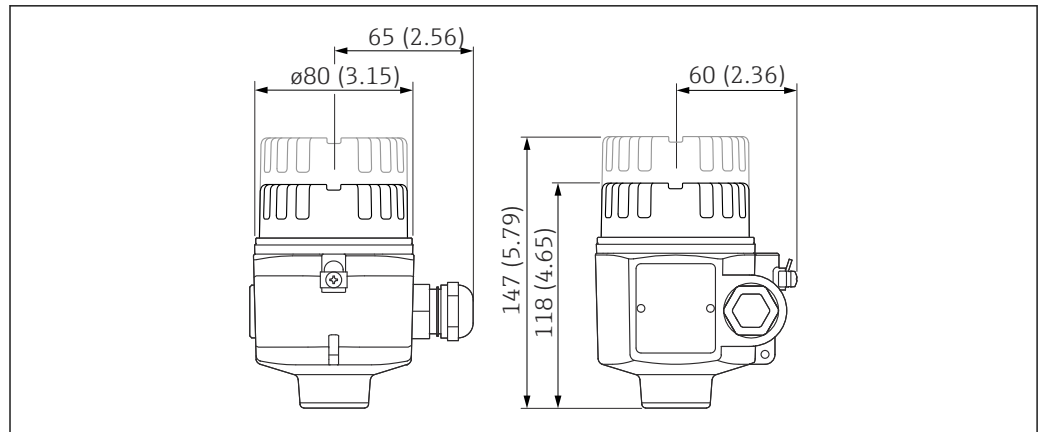

A0040694

Unit of measurement mm (in)

Stainless steel housing F27

With the gas-tight process seal.

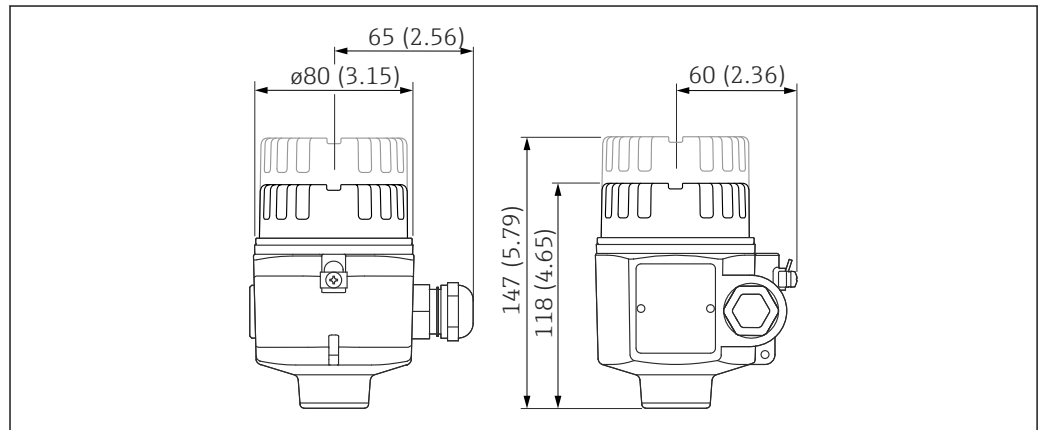

A0040694

Unit of measurement mm (in)

Aluminum housing T13

With separate connection compartment and gas-tight process seal.

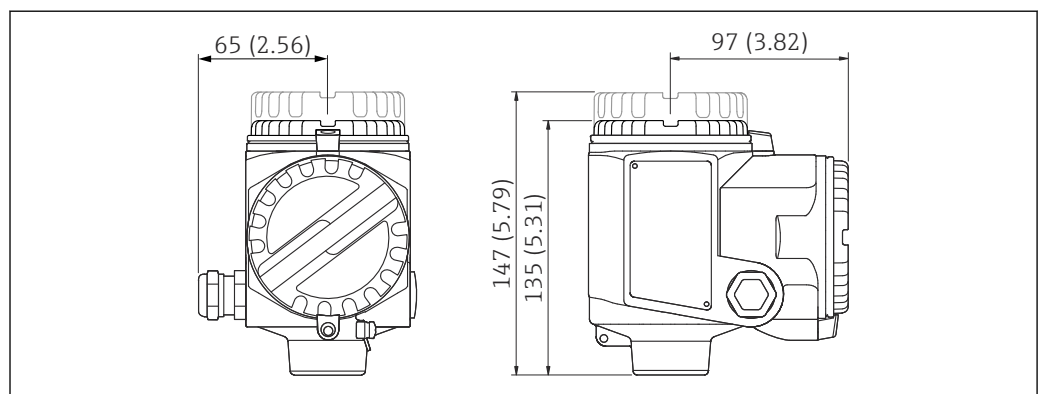

A0040695

Unit of measurement mm (in)

The extension height of housing with adapter

List of abbreviations:

- G - order code
- H1 - height without display
- H2 - height with display

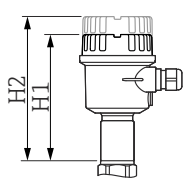
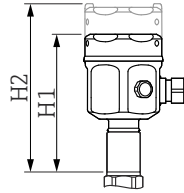
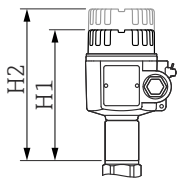
	A ¹⁾	B ²⁾	C ³⁾
	 <small>A0040696</small>	 <small>A0040697</small>	 <small>A0040698</small>
G	2	1	3
H1	143 mm (5.63 in)	141 mm (5.55 in)	150 mm (5.91 in)
H2	162 mm (6.38 in)	179 mm (7.05 in)	179 mm (7.05 in)

- 1) Polyester housing F16
- 2) Stainless steel housing F15
- 3) Stainless steel housing F17

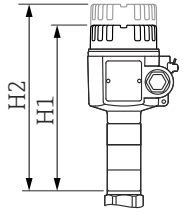
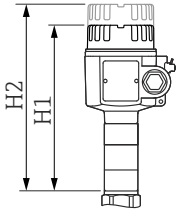
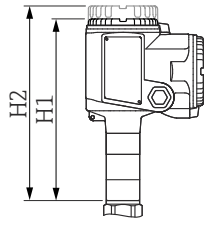
	D ¹⁾	E ²⁾	F ³⁾
	 <small>A0040699</small>	 <small>A0040699</small>	 <small>A0040700</small>
G	4	6	5
H1	194 mm (7.64 in)	194 mm (7.64 in)	210 mm (8.27 in)
H2	223 mm (8.78 in)	223 mm (8.78 in)	223 mm (8.78 in)

- 1) Aluminum housing F13
- 2) Stainless steel housing F27
- 3) Aluminum housing T13

Process connections

Thread G - DIN EN ISO 228-1

Seal material: elastomer

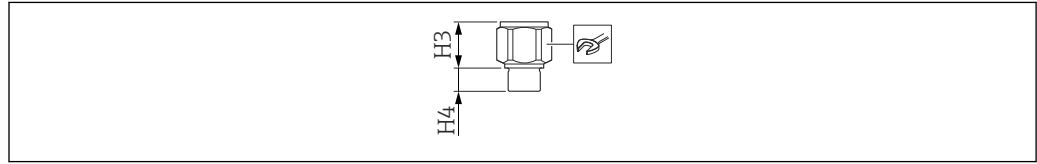

A0042280

22 Process connection with thread G overview

List of abbreviations:

- p_{\max} - maximum pressure value
- H3 - cone heights
- H4 - thread heights

Ø 10 mm (0.39 in)			Ø 14 mm (0.55 in)	
Version				
G½	G¾	G1	G¾	G1
Order code				
GCJ	GDJ	GEJ	GDJ	GEJ
p_{\max}				
25 bar (362.5 psi)	25 bar (362.5 psi)	25 bar (362.5 psi)	25 bar (362.5 psi)	25 bar (362.5 psi)
H3				
38 mm (1.5 in)	38 mm (1.5 in)	38 mm (1.5 in)	38 mm (1.5 in)	38 mm (1.5 in)
H4				
19 mm (0.75 in)	19 mm (0.75 in)	19 mm (0.75 in)	19 mm (0.75 in)	19 mm (0.75 in)
A0011222				
41	41	41	41	41

List of abbreviations:

- p_{\max} - maximum pressure value
- H3 - cone heights
- H4 - thread heights

Ø 16 mm (0.63 in)			Ø 22 mm (0.87 in)
Version			
G¾	G1	G1½	G1½
Order code			
GDJ	GEJ	GGJ	GGJ
p_{\max}			
25 bar (362.5 psi)	25 bar (362.5 psi)	100 bar (1 450 psi)	50 bar (725 psi)
H3			
38 mm (1.5 in)	38 mm (1.5 in)	41 mm (1.61 in)	85 mm (3.35 in)
H4			
19 mm (0.75 in)	19 mm (0.75 in)	25 mm (0.98 in)	25 mm (0.98 in)

Ø 16 mm (0.63 in)		Ø 22 mm (0.87 in)	
 A0011222			
41	41	55	55

Thread NPT - ANSI B 1.20.1

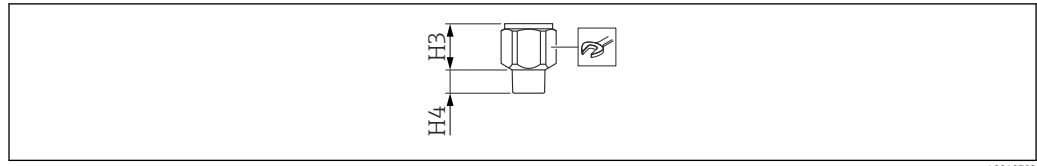

A0040702

23 Process connection with a NPT overview

List of abbreviations:

- p_{\max} - maximum pressure value
- H3 - cone heights
- H4 - thread heights

Ø 10 mm (0.39 in)			Ø 14 mm (0.55 in)	
Version				
NPT $\frac{1}{2}$	NPT $\frac{3}{4}$	NPT1	NPT $\frac{3}{4}$	NPT1
Order code				
RCJ	RDJ	REJ	RDJ	REJ
p_{\max}				
25 bar (362.5 psi)	25 bar (362.5 psi)	25 bar (362.5 psi)	25 bar (362.5 psi)	25 bar (362.5 psi)
H3				
38 mm (1.5 in)	38 mm (1.5 in)	38 mm (1.5 in)	38 mm (1.5 in)	38 mm (1.5 in)
H4				
19 mm (0.75 in)	19 mm (0.75 in)	19 mm (0.75 in)	19 mm (0.75 in)	19 mm (0.75 in)
A0011222				
41	41	41	41	41

List of abbreviations:

- p_{\max} - maximum pressure value
- H3 - cone heights
- H4 - thread heights

Ø 16 mm (0.63 in)			Ø 22 mm (0.87 in)
Version			
NPT $\frac{3}{4}$	NPT1	NPT1 $\frac{1}{2}$	NPT1 $\frac{1}{2}$
Order code			
RDJ	REJ	RGJ	RGJ
p_{\max}			
25 bar (362.5 psi)	25 bar (362.5 psi)	100 bar (1 450 psi)	50 bar (725 psi)
H3			
38 mm (1.5 in)	38 mm (1.5 in)	41 mm (1.61 in)	85 mm (3.35 in)
H4			
19 mm (0.75 in)	19 mm (0.75 in)	25 mm (0.98 in)	25 mm (0.98 in)
A0011222			
41	41	55	55

Threaded pipe joint - DIN 11851

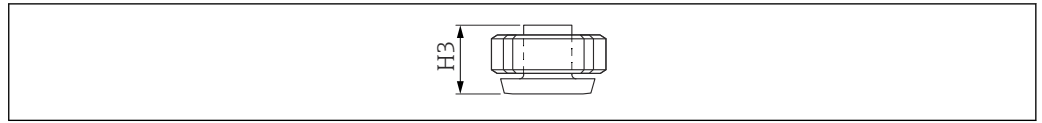

A0040703

24 Threaded pipe joint overview

List of abbreviations:

- p_{max} - maximum pressure value
- H3 - cone heights

\varnothing 10 mm (0.39 in)	\varnothing 14 mm (0.55 in)	\varnothing 16 mm (0.63 in)
Version		
DN50 PN40	DN50 PN40	DN50 PN40
Order code		
MRJ	MRJ	MRJ
p_{max}		
25 bar (362.5 psi)	25 bar (362.5 psi)	40 bar (580 psi)
H3		
57 mm (2.24 in)	66 mm (2.6 in)	66 mm (2.6 in)
Surface roughness ¹⁾		
$\leq 0.8 \mu\text{m}$ (31.5 μin)	$\leq 0.8 \mu\text{m}$ (31.5 μin)	$\leq 0.8 \mu\text{m}$ (31.5 μin)

1) Not in conjunction with inactive length

Tri-Clamp - ISO2852

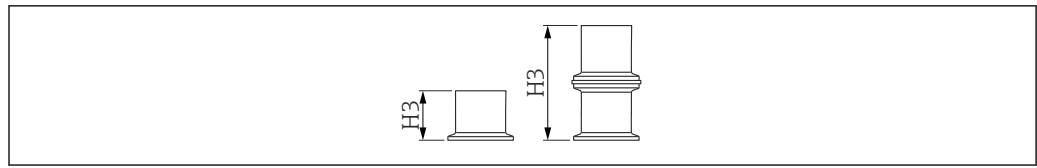

A0040704

25 Tri-Clamp process connection overview

List of abbreviations:

- p_{\max} - maximum pressure value
- H3 - cone heights

Ø 10 mm (0.39 in)		Ø 14 mm (0.55 in)		
Version				
DN25 1 in	DN38 1.5 in	DN25 1 in	DN38 1.5 in	DN40-51 2 in
Order code				
TCJ	TJJ	TCJ	TNJ	TDJ
p_{\max}¹⁾				
25 bar (362.5 psi)	25 bar (362.5 psi)	25 bar (362.5 psi)	25 bar (362.5 psi)	25 bar (362.5 psi)
H3				
57 mm (2.24 in)	57 mm (2.24 in)	66 mm (2.6 in)	66 mm (2.6 in)	66 mm (2.6 in)
Surface roughness²⁾				
≤ 0.8 µm (31.5 µin)	≤ 0.8 µm (31.5 µin)	≤ 0.8 µm (31.5 µin)	≤ 0.8 µm (31.5 µin)	≤ 0.8 µm (31.5 µin)

1) In the event of CRN approval, the maximum permitted process pressure is 11 bar (159.5 psi).

2) Not in conjunction with inactive length

Ø 16 mm (0.63 in)	
Version	
DN38 1.5 in	DN40-51 2 in
Order code	
TNJ	TDJ
p_{\max}¹⁾	
16 bar (232 psi)	16 bar (232 psi)
H3	
98 mm (3.86 in) ²⁾	66 mm (2.6 in)
Surface roughness³⁾	
≤ 0.8 µm (31.5 µin)	≤ 0.8 µm (31.5 µin)

1) In the event of CRN approval, the maximum permitted process pressure is 11 bar (159.5 psi).

2) Process connection: Tri-Clamp (47 mm (1.85 in)) with seal (2 mm (0.08 in)) and removable clamp (49 mm (1.93 in)).

3) Not in conjunction with inactive length

Tri-Clamp clad - ISO2852

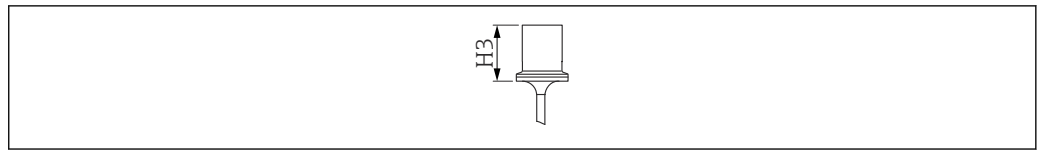

A0040705

26 Tri-Clamp clad overview

List of abbreviations:

- p_{max} - maximum pressure value
- H3 - cone heights

Ø 14 mm (0.55 in)		Ø 16 mm (0.63 in)	
Version			
DN38 1.5 in	DN40-51 2 in	DN38 1.5 in	DN40-51 2 in
Order code			
TJK	TDK	TJK	TDK
p_{max}¹⁾			
16 bar (232 psi)	16 bar (232 psi)	16 bar (232 psi)	16 bar (232 psi)
H3			
66 mm (2.6 in)	66 mm (2.6 in)	66 mm (2.6 in)	66 mm (2.6 in)
Surface roughness²⁾			
≤ 0.8 µm (31.5 µin)	≤ 0.8 µm (31.5 µin)	≤ 0.8 µm (31.5 µin)	≤ 0.8 µm (31.5 µin)

- 1) In the event of CRN approval, the maximum permitted process pressure is 11 bar (159.5 psi).
- 2) Not in conjunction with inactive length

Flanges

 The process pressure depends on the chosen flange.

EN1092-1

ANSI B 16.5

JIS B2220

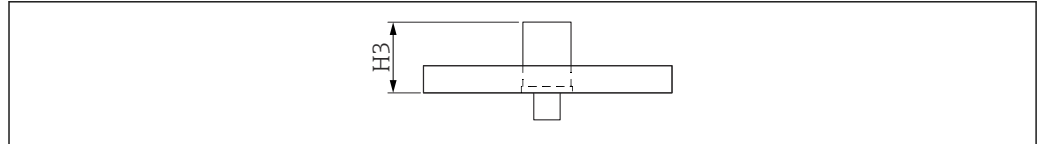

Version and order code:

- EN / B##
- ANSI / A##
- JIS / K##



A0040706

 27 Flange overview

	Ø 10 mm (0.39 in)	Ø 16 mm (0.63 in)	Ø 22 mm (0.87 in)
p_{max} ¹⁾			
	25 bar (362.5 psi)	100 bar (1450 psi)	50 bar (725 psi)
H3			
	57 mm (2.24 in)	66 mm (2.6 in)	111 mm (4.37 in)
Dimensions with inactive length			
	-	56 mm (2.2 in)	-
Additional information			
	 2)	 2)	 3)

- 1) Depends on flange
 2) Also clad (PTFE)
 3) Only clad (PTFE)

Hygiene connections

Thread G³/₄ with flush-mounted seal

For weld-in adapter, see chapter "Accessories" → 56.

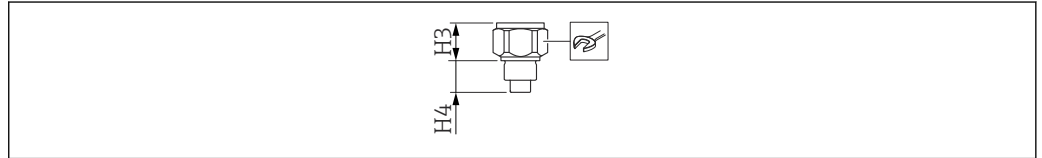

A0040707

28 Hygiene connection with G³/₄ thread with flush-mounted seal. Overview

List of abbreviations:

- p_{max} - maximum pressure value
- H3 - cone heights
- H4 - thread heights

Ø 10 mm (0.39 in)	
Version	G ³ / ₄
Order code	GQJ
P_{max}	25 bar (362.5 psi)
H3	31 mm (1.22 in)
H4	26 mm (1.02 in)
	<small>A0011222</small>
	41

Thread G1 with flush-mounted seal

For weld-in adapter see "Accessories" →  56.

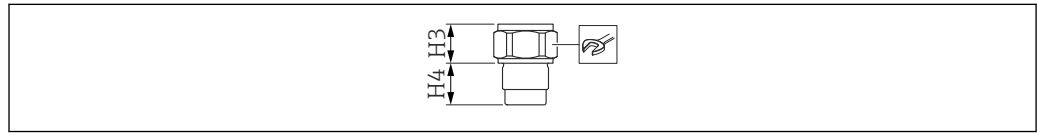

A0040708

 29 *Hygiene connection with G1 thread with flush-mounted seal. Overview*

List of abbreviations:

- p_{\max} - maximum pressure value
- H3 - cone heights
- H4 - thread heights

Ø 10 mm (0.39 in)	
Version	G1
Order code	GWJ
P_{\max}	25 bar (362.5 psi)
H3	27 mm (1.06 in)
H4	30 mm (1.18 in)
	A0011222
	41

Adapter 44 mm (1.73 in) with flush-mounted seal

Version

Universal adapter

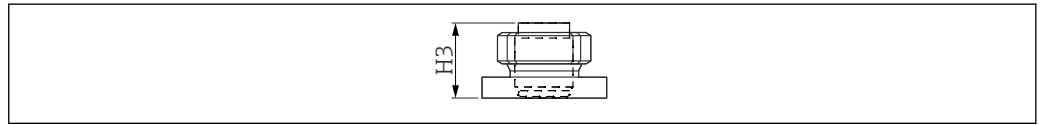

A0040709

30 Adapter 44 mm (1.73 in) with flush-mounted seal. Overview

Ø 16 mm (0.63 in) / Ø 14 mm (0.55 in)	
Order code	UPJ
P_{max} ¹⁾	16 bar (232 psi)
H3	57 mm (2.24 in)

1) Tightening torque 10 Nm (7.37 lbf ft)

Fully insulated rod probes

The active rod probe length L_1 is always fully insulated.

Total length of probe from sealing surface: $L = L_1 + L_3$ (+ 125 mm (4.92 in) with active buildup compensation + H_3 ⁷⁾)

Thickness of insulation:

- 10 mm (0.39 in) rod probe: 1 mm (0.04 in)
- 16 mm (0.63 in) rod probe: 2 mm (0.08 in)
- 22 mm (0.87 in) rod probe: 2 mm (0.08 in)

Length tolerances L_1 , L_3 :

- < 1 m (3.3 ft): 0 to -5 mm (0 to -0.2 in)
- 1 to 3 m (3.3 to 9.8 ft): 0 to -10 mm (0 to -0.39 in)
- 3 to 6 m (9.8 to 20 ft): 0 to -20 mm (0 to -0.79 in)

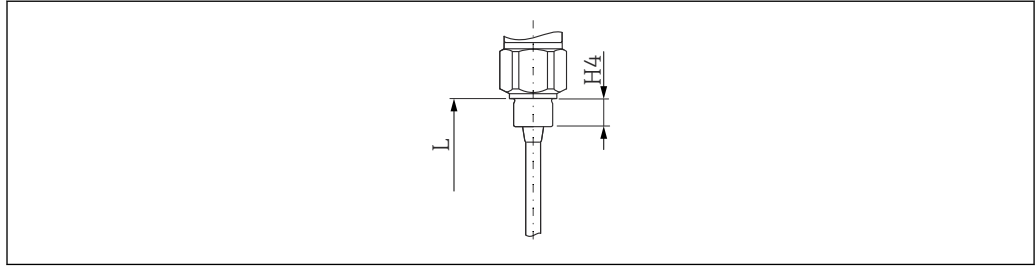

A0040736

31 The probe with G thread

L The total length of the probe

H_4 Thread height. Important value for calculating the exact probe length for process connections with a thread

→ 26

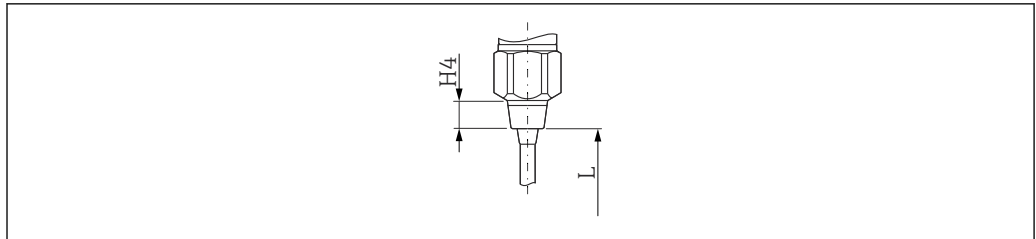

A0044656

32 The probe with the conical thread NPT

L The total length of the probe

H_4 Thread height. Important value for calculating the exact probe length for process connections with a thread

→ 26

7) Thread height, important for calculating the exact probe length for process connections with a thread → 26.

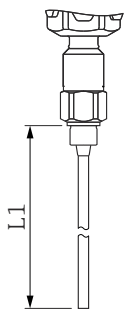
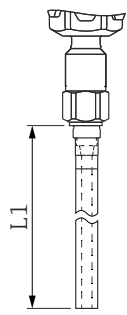
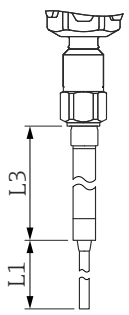
A ¹⁾		B ²⁾		C ³⁾	
					
A0042617		A0042618		A0042619	
Total length (L)					
100 to 4 000 mm (3.94 to 157 in)		100 to 4 000 mm (3.94 to 157 in)		200 to 6 000 mm (7.87 to 236 in)	
Active rod length (L1)					
100 to 4 000 mm (3.94 to 157 in)		100 to 4 000 mm (3.94 to 157 in)		100 to 4 000 mm (3.94 to 157 in)	
Inactive rod length (L3)					
-		-		100 to 2 000 mm (3.94 to 78.7 in)	
Probe rod diameter					
10 mm (0.39 in)	16 mm (0.63 in)	10 mm (0.39 in)	16 mm (0.63 in)	10 mm (0.39 in)	16 mm (0.63 in)
Ground tube diameter					
-		22 mm (0.87 in)	43 mm (1.69 in)	-	
Inactive length diameter					
-		-		22 mm (0.87 in)	43 mm (1.69 in)
Active buildup compensation diameter					
-		-		-	
Length of active buildup compensation					
-		-		-	
Lateral loading capacity at 20 °C (68 °F) less than					
15 Nm (11.06 lbf ft)	30 Nm (22.12 lbf ft)	40 Nm (29.5 lbf ft)	300 Nm (221.2 lbf ft)	30 Nm (22.12 lbf ft)	60 Nm (44.2 lbf ft)
For use in agitating tanks					
-		-	✓	-	
For aggressive liquids					
✓		-		-	
For high-viscosity liquids					
✓		-		✓	
For use in plastic tanks					
-		✓		-	
For use in mounting nozzles					
-		-		✓	
The probe can be used in the event of condensate on tank ceiling					
-		-		✓	

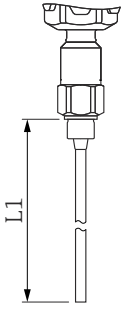
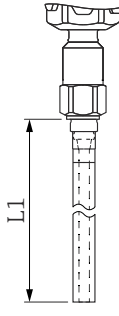
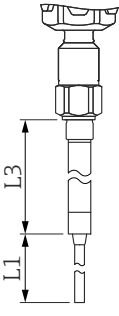
A ¹⁾	B ²⁾	C ³⁾
 <small>A0042617</small>	 <small>A0042618</small>	 <small>A0042619</small>
For high-viscosity conductive liquids		
-	-	-

- 1) Rod probe
- 2) Rod probe with ground tube
- 3) Rod probe with inactive length

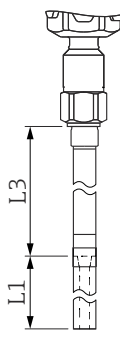
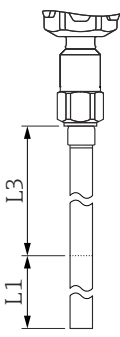
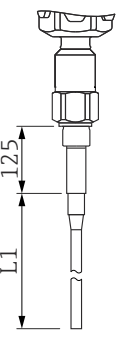
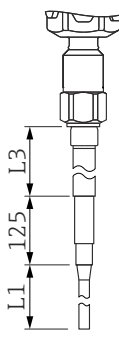
D ¹⁾	E ²⁾	F ³⁾	G ⁴⁾			
 <small>A0042620</small>	 <small>A0042621</small>	 <small>A0042622</small>	 <small>A0042623</small>			
Total length (L)						
200 to 6000 mm (7.87 to 236 in)	300 to 4000 mm (11.8 to 157 in)	225 to 4125 mm (8.86 to 162 in)	325 to 6000 mm (12.8 to 236 in)			
Active rod length (L1)						
100 to 4000 mm (3.94 to 157 in)	150 to 3000 mm (5.91 to 118 in)	100 to 4000 mm (3.94 to 157 in)	100 to 4000 mm (3.94 to 157 in)			
Inactive rod length (L3)						
100 to 2000 mm (3.94 to 78.7 in)	150 to 1000 mm (5.91 to 118 in)	-	100 to 2000 mm (3.94 to 78.7 in)			
Probe rod diameter						
10 mm (0.39 in)	16 mm (0.63 in)	22 mm (0.87 in) ⁵⁾	10 mm (0.39 in)	16 mm (0.63 in)	10 mm (0.39 in)	16 mm (0.63 in)
Ground tube diameter						
22 mm (0.87 in)	43 mm (1.69 in)	-	-	-	-	-
Inactive length diameter						
22 mm (0.87 in)	43 mm (1.69 in)	22 mm (0.87 in) ⁵⁾	-	-	22 mm (0.87 in)	43 mm (1.69 in)
Active buildup compensation diameter						
-	-	19 mm (0.75 in)	26 mm (1.02 in)	19 mm (0.75 in)	26 mm (1.02 in)	26 mm (1.02 in)
Length of active buildup compensation						
-	-	125 mm (4.92 in)		125 mm (4.92 in)		-
Lateral loading capacity at 20 °C (68 °F) less than						

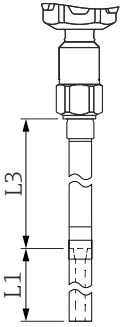
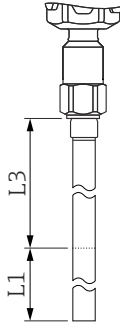
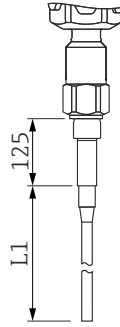
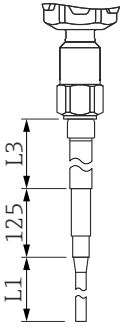
D ¹⁾		E ²⁾		F ³⁾		G ⁴⁾	
							
A0042620		A0042621		A0042622		A0042623	
40 Nm (29.5 lbf ft)	300 Nm (221.2 lbf ft)	25 Nm (18.4 lbf ft)		30 Nm (22.12 lbf ft)	60 Nm (44.2 lbf ft)	30 Nm (22.12 lbf ft)	60 Nm (44.2 lbf ft)
For use in agitating tanks							
-	✓	-	-	-	-	-	-
For aggressive liquids							
-	✓	-	-	-	-	-	-
For high-viscosity liquids							
-	✓	✓	✓	✓	✓	✓	✓
For use in plastic tanks							
✓	-	-	-	-	-	-	-
For use in mounting nozzles							
✓	✓	-	-	-	-	✓	✓
The probe can be used in the event of condensate on tank ceiling							
✓	✓	-	-	-	-	✓	✓
For high-viscosity conductive liquids							
-	-	✓	✓	✓	✓	✓	✓

- 1) Rod probe with inactive length and ground tube
- 2) Rod probe with fully insulated inactive length
- 3) Rod probe with active buildup compensation
- 4) Rod probe with inactive length and active buildup compensation
- 5) Probe tube

Fully insulated rod probes for hygiene applications



Total length of probe from sealing surface: $L = L1 + L3$ (+ 125 mm (4.92 in) with active buildup compensation).

Thickness of insulation:

- 14 mm (0.55 in) rod probe: 2 mm (0.08 in)
- 16 mm (0.63 in) rod probe: 2 mm (0.08 in)

Length tolerances L1, L3:

- < 1 m (3.3 ft): 0 to -5 mm (0 to -0.2 in)
- < 1 to 3 m (3.3 to 9.8 ft): 0 to -10 mm (0 to -0.39 in)
- < 3 to 6 m (9.8 to 20 ft): 0 to -20 mm (0 to -0.79 in)

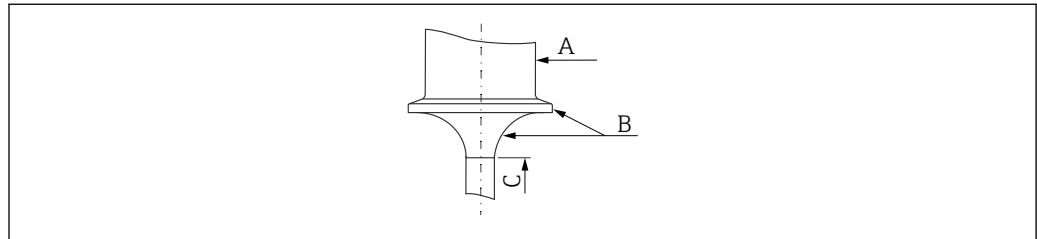

A0040742

- A 316L
- B PTFE
- C PFA

A ¹⁾	B ²⁾
<small>A0040743</small>	<small>A0042624</small>
Total length (L)	
100 to 4 000 mm (3.94 to 157 in)	200 to 2 125 mm (7.87 to 83.7 in)
Active rod length (L1)	
100 to 4 000 mm 3.94 to 157 in	75 to 2 000 mm (2.95 to 78.7 in)
Probe rod diameter	
16 mm (0.63 in)	14 mm (0.55 in)
Ground tube diameter	
-	-
Inactive length diameter	
-	-
Active buildup compensation diameter	
-	14 mm (0.55 in)
Length of active buildup compensation	
-	125 mm (4.92 in)
Lateral loading capacity at 20 °C (68 °F)	
< 30 Nm (22.12 lbf ft)	< 15 Nm (0.59 lbf ft)
For use in agitating tanks	

A ¹⁾	B ²⁾
-	-
For aggressive liquids	
✓	✓
For high-viscosity liquids	
✓	✓
For use in plastic tanks	
-	-
For use in mounting nozzles	
-	✓
The probe can be used in the event of condensate on tank ceiling	
-	✓
For high-viscosity conductive liquids	
-	✓

- 1) Rod probe with clad Tri-Clamp
- 2) Rod probe with fully insulated active buildup compensation and clad Tri-Clamp

Partially insulated rod probes for a switch point with millimeter accuracy in conductive liquids

i Total length of probe from sealing surface: $L = L1 + L3$ (+ 125 mm (4.92 in) with active buildup compensation + $H3$ ⁸⁾)

Thickness of insulation:

- 10 mm (0.39 in) rod probe: 1 mm (0.04 in)
- 16 mm (0.63 in) rod probe: 2 mm (0.08 in)

Length tolerances L1, L3:

- < 1 m (3.3 ft): 0 to -5 mm (0 to -0.2 in)
- 1 to 3 m (3.3 to 9.8 ft): 0 to -10 mm (0 to -0.39 in)
- 3 to 6 m (9.8 to 20 ft): 0 to -20 mm (0 to -0.79 in)

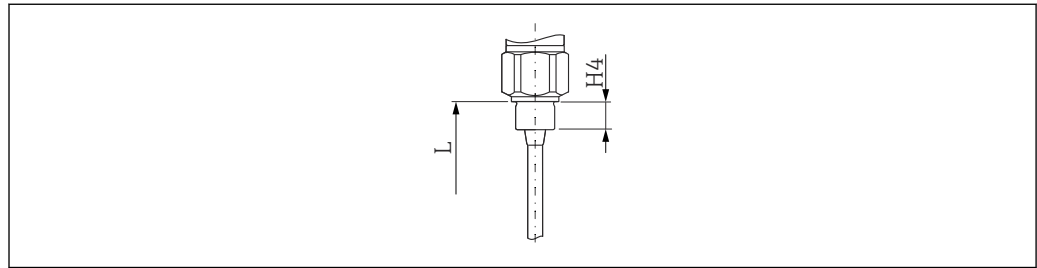

A0040736

33 The probe with G thread

L The total length of the probe

H4 Thread height. Important value for calculating the exact probe length for process connections with a thread

→ **26**

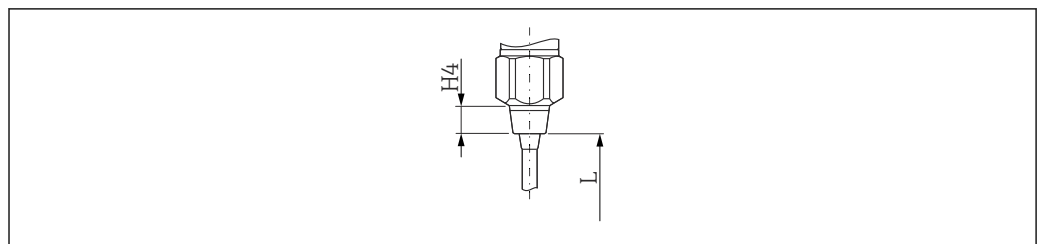

A0044656

34 The probe with the conical thread NPT

L The total length of the probe

H4 Thread height. Important value for calculating the exact probe length for process connections with a thread

→ **26**

A ¹⁾	B ²⁾	C ³⁾
<p style="text-align: right; font-size: small;">A0042625</p>	<p style="text-align: right; font-size: small;">A0042626</p>	<p style="text-align: right; font-size: small;">A0042627</p>
Total length (L)		
100 to 4 000 mm (3.94 to 157 in)	100 to 4 000 mm (3.94 to 157 in)	200 to 6 000 mm (7.87 to 236 in)

8) Thread height, important for calculating the exact probe length for process connections with a thread → **26**.

A ¹⁾		B ²⁾		C ³⁾	
Active rod length (L1)					
100 to 4 000 mm (3.94 to 157 in)		100 to 4 000 mm (3.94 to 157 in)		100 to 4 000 mm (3.94 to 157 in)	
Length of partial insulation (L2)					
75 to 3 950 mm (2.95 to 156 in)		75 to 3 950 mm (2.95 to 156 in)		75 to 3 950 mm (2.95 to 156 in)	
Inactive rod length (L3)					
-		-		100 to 2 000 mm (3.94 to 78.7 in)	
Probe rod diameter					
10 mm (0.39 in)	16 mm (0.63 in)	10 mm (0.39 in)	16 mm (0.63 in)	10 mm (0.39 in)	16 mm (0.63 in)
Inactive length diameter or ground tube diameter					
-		22 mm (0.87 in)	43 mm (1.69 in)	22 mm (0.87 in)	43 mm (1.69 in)
Active buildup compensation diameter					
-		-		-	
Length of active buildup compensation					
-		-		-	
Lateral loading capacity at 20 °C (68 °F) less than					
15 Nm (11.06 lbf ft)	30 Nm (22.12 lbf ft)	40 Nm (29.5 lbf ft)	300 Nm (221.2 lbf ft)	30 Nm (22.12 lbf ft)	60 Nm (44.2 lbf ft)
For use in agitating tanks					
-		-	✓	-	
For aggressive liquids					
-		-		-	
For high-viscosity liquids					
✓		-		✓	
For use in plastic tanks					
-		✓		-	
For use in mounting nozzles					
-		-		✓	
The probe can be used in the event of condensate on tank ceiling					
-		-		✓	
For high-viscosity conductive liquids					
-		-		-	

- 1) Rod probe
2) Rod probe with ground tube
3) Rod probe with inactive length

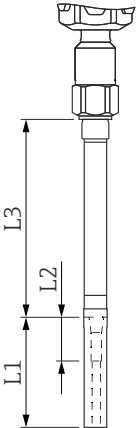
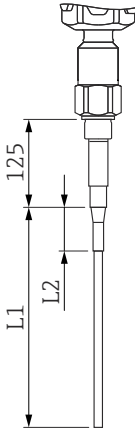
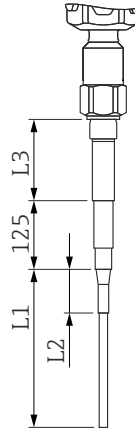
D ¹⁾		E ²⁾		F ³⁾	
					
A0042628		A0042629		A0042630	
Total length (L)					
200 to 6000 mm (7.87 to 236 in)		225 to 4000 mm (8.86 to 157 in)		100 to 6000 mm (3.94 to 236 in)	
Active rod length (L1)					
100 to 4000 mm (3.94 to 157 in)		100 to 4000 mm (3.94 to 157 in)		100 to 4000 mm (3.94 to 157 in)	
Length of partial insulation (L2)⁴⁾					
75 to 3950 mm (2.95 to 156 in)		75 to 3950 mm (2.95 to 156 in)		75 to 3950 mm (2.95 to 156 in)	
Inactive rod length (L3)					
100 to 2000 mm (3.94 to 78.7 in)		-		100 to 2000 mm (3.94 to 78.7 in)	
Probe rod diameter					
10 mm (0.39 in)	16 mm (0.63 in)	10 mm (0.39 in)	16 mm (0.63 in)	10 mm (0.39 in)	16 mm (0.63 in)
Inactive length diameter or ground tube diameter					
22 mm (0.87 in)	43 mm (1.69 in)	-		22 mm (0.87 in)	43 mm (1.69 in)
Active buildup compensation diameter					
-		19 mm (0.75 in)	26 mm (1.02 in)	19 mm (0.75 in)	26 mm (1.02 in)
Length of active buildup compensation					
-		125 mm (4.92 in)		125 mm (4.92 in)	
Lateral loading capacity at 20 °C (68 °F) less than					
40 Nm (29.5 lbf ft)	300 Nm (221.2 lbf ft)	30 Nm (22.12 lbf ft)	60 Nm (44.2 lbf ft)	30 Nm (22.12 lbf ft)	60 Nm (44.2 lbf ft)
For use in agitating tanks					
-	✓	-	-	-	-
For aggressive liquids					
-	-	-	-	-	-
For high-viscosity liquids					
-	-	✓	-	✓	✓
For use in plastic tanks					
✓	-	-	-	-	-
For use in mounting nozzles					
✓	-	-	-	✓	✓
The probe can be used in the event of condensate on tank ceiling					
✓	-	-	-	✓	✓

D ¹⁾	E ²⁾	F ³⁾
For high-viscosity conductive liquids		
-	✓	✓

- 1) Rod probe with inactive length and ground tube
- 2) Rod probe with active buildup compensation
- 3) Rod probe with inactive length and active buildup compensation
- 4) The L2 length must be > 25 mm (0.98) shorter than L1

Weight

Housing with process connection:

- F15, F16, F17, F13 approximately 4.00 kg (8.82 lb)
- T13 approximately 4.50 kg (9.92 lb)
- F27 approximately 5.50 kg (10.1 lb)

Flange weight

- Probe rod 10 mm (0.39 in): 0.5 kg/m (0.34 lb/ft)
- Probe rod 14 mm (0.55 in): 1.1 kg/m (0.74 lb/ft)
- Probe rod 16 mm (0.63 in): 1.1 kg/m (0.74 lb/ft)
- Probe rod 22 mm (0.87 in): 0.8 kg/m (0.54 lb/ft)

Technical data: probe**Capacitance values of the probe**

The basic capacitance of the probe is approximately 18 pF.

Additional capacitance

Mount the probe at a minimum distance of 50 mm (1.97 in) from a conductive container wall: approximately 1.3 pF/100 mm (3.94 in) in the air for a rod probe

Fully insulated probe rod in water:

- approximately 38 pF/100 mm (3.94 in) for 16 mm (0.63 in) rod
- approximately 45 pF/100 mm (3.94 in) for 10 mm (0.39 in) rod
- approximately 50 pF/100 mm (3.94 in) for 22 mm (0.87 in) rod
- approximately 74 pF/100 mm (3.94 in) for 14 mm (0.55 in) rod
-

Rod probe with the ground tube:

- approximately 6.4 pF/100 mm (3.94 in) in air
- approximately 38 pF/100 mm (3.94 in) in water for 16 mm (0.63 in) probe rod
- approximately 45 pF/100 mm (3.94 in) in water for 10 mm (0.39 in) probe rod

Materials

Material specifications as per AISI and DIN-EN.

In contact with the process

- probe rod, ground tube, inactive length, tensioning weight for rope probe: 316L (1.4435 or 1.4404)
- probe rod insulation:
 - if PFA selected: PFA (FDA 21 CFR 177.1550)
 - if PTFE selected: PTFE and PFA (FDA 21 CFR 177.1550)
- process connection: 316L (1.4435 or 1.4404)
- flat seal for process connection G³/₄ or G1: elastomer fiber, asbestos-free
- sealing ring for process connection G¹/₂, G³/₄, G1, G1¹/₂: elastomer fiber, asbestos-free, resistant to lubricants, solvents, steam, weak acids, and alkalis to 300 °C (572 °F) and to 100 bar (1450 psi)

Not in contact with the process

- ground terminals on housing (exterior): 304 (1.4301)
- the nameplate on housing (exterior): 304 (1.4301)
- cable glands:
 - housing F13, F15, F16, F17, F27: polyamide (PA) with C, D, E, F, H, M, J, P, S, 1, 4, 5, approval: nickel-plated brass
 - housing T13: nickel-plated brass
- polyester housing F16: PBT-FR with a cover made of PBT-FR or with sight glass made of PA12
 - cover seal: EPDM
 - adhesive nameplate: polyester foil (PET)
 - pressure compensation filter: PBT-GF20

- stainless steel housing F15: 316L (1.4404)
 - cover seal: silicone
 - cover clamp: 304 (1.4301)
 - pressure compensation filter: PBT-GF20, PA
- aluminum housing F17/F13/T13: EN-AC-ALSi10Mg, plastic-coated
 - cover seal: EPDM
 - cover clamp: nickel-plated brass
 - pressure compensation filter: silicone (not T13)
- stainless steel housing F27: 316L (1.4435)
 - cover seal: FVMQ, optional: EPDM seal available as a spare part
 - cover clamp: 316L (1.4435)

Operability

2-wire AC electronic insert FEI51

Power supply

- Supply voltage: 19 to 253 V_{AC}
- Power consumption: < 1.5 W
- Residual current consumption: < 3.8 mA
- Short-circuit protection
- Overvoltage category: II

Electrical connection

 Connect the electronic insert in series with an external load.

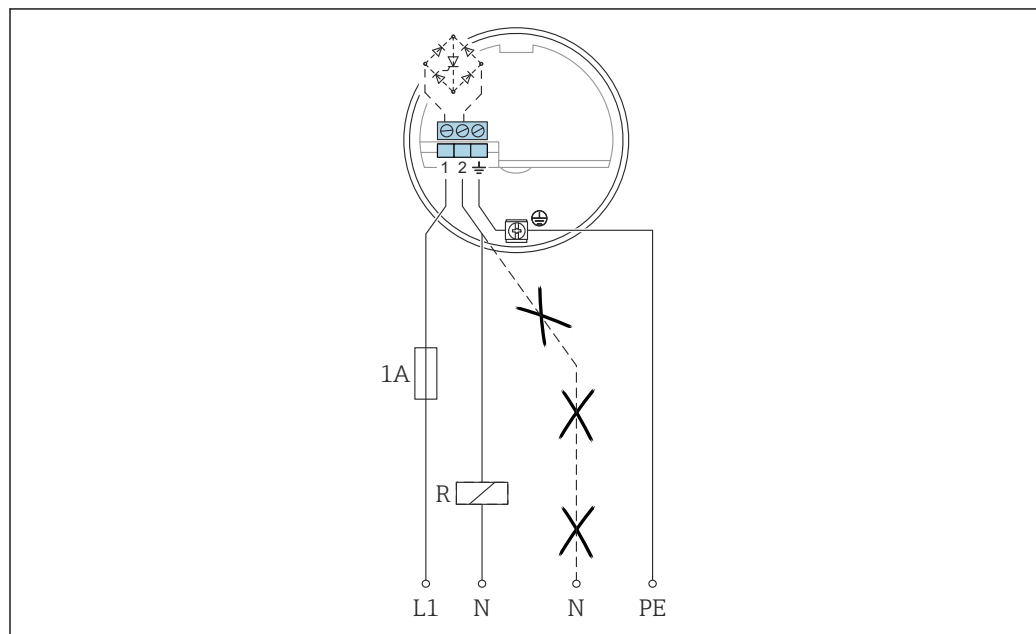

A0042387

L1 L1 phase cable
N Neutral cable
PE Grounding cable
R External load

Make sure that:

- the residual current consumption is in blocked state.
- for low voltage:
 - voltage drop across the load is such that the minimum terminal voltage at the electronic insert 19 V when blocked is not undershot
 - voltage drop across the electronics when switched through is observed (up to 12 V)
- a relay cannot de-energize with holding power below 1 mA⁹⁾

When selecting the relay, pay attention to the holding power and rated power.

Signal on alarm

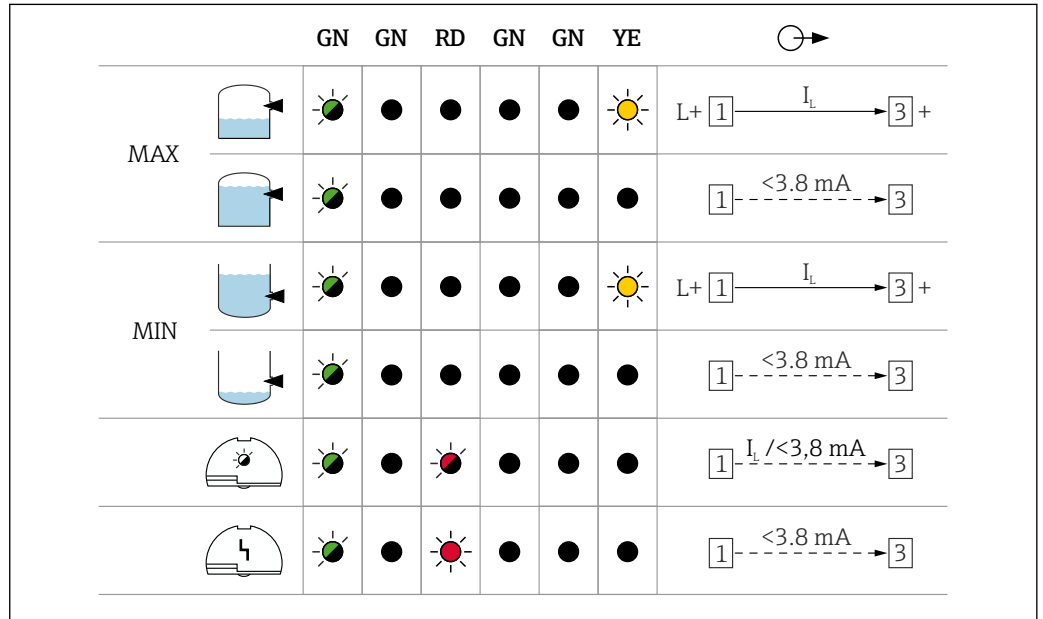

A0042586

Output signal

Output signal on power failure or in the event of damage to the sensor: < 3.8 mA

Connectable load

- For relays with a minimum holding power or rated power:
 - > 2.5 VA at 253 V_{AC} (10 mA)
 - > 0.5 VA at 24 V_{AC} (20 mA)
- Relays with a lower holding power or rated power can be operated by means of an RC module connected in parallel.
- For relays with a maximum holding power or rated power:
 - < 89 VA at 253 V_{AC}
 - < 8.4 VA at 24 V_{AC}
- Voltage drop across FEI51: maximum 12 V
- Residual current with blocked thyristor: 3.8 mA
- Load switched directly into the power supply circuit via the thyristor.

DC PNP electronic insert FEI52

Power supply

- Supply voltage: 10 to 55 V_{DC}
- Ripple:
 - maximum 1.7 V
 - 0 to 400 Hz
- Current consumption: < 20 mA
- Power consumption without load: maximum 0.9 W
- Power consumption with full load (350 mA): 1.6 W

9) If not: A resistor should be connected parallel to the relay (RC module available on request).

- Reverse polarity protection: yes
- Separation voltage: 3.7 kV
- Overvoltage category: II

Electrical connection

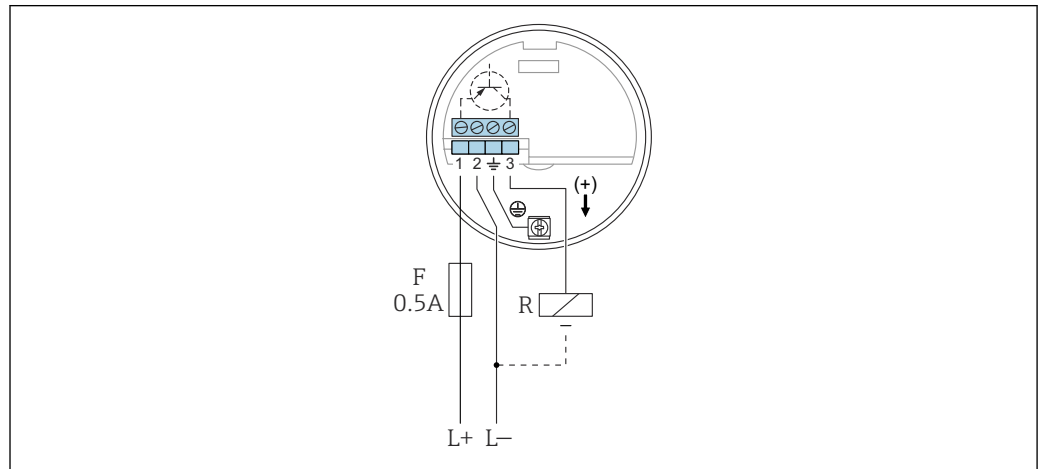

A0042388

- L+ Power input +
- L- Power input -
- F Fuse 0.5 A
- R External load: $I_{max} = 350 \text{ mA}$ $U_{max} = 55 \text{ V}_{DC}$

Preferably in conjunction with programmable logic controllers (PLC), DI modules in accordance with EN 61131-2.

Positive signal present at the switch output of the electronic system (PNP).

Output signal

		GN	GN	RD	GN	GN	YE	
MAX								$L+ \text{ [1] } \xrightarrow{I_L} \text{ [3] } +$
								$\text{[1]} \text{---} \xrightarrow{I_R} \text{ [3]}$
MIN								$L+ \text{ [1] } \xrightarrow{I_L} \text{ [3] } +$
								$\text{[1]} \text{---} \xrightarrow{I_R} \text{ [3]}$
								$\text{[1]} \text{---} \xrightarrow{I_L / I_R} \text{ [3]}$
								$\text{[1]} \text{---} \xrightarrow{I_R} \text{ [3]}$

A0042587

Signal on alarm

Output signal on power failure or in the event of device failure:
 $I_R < 100 \mu\text{A}$

Connectable load

- Load switched via transistor and separate PNP connection: maximum 55 V
- Load current: maximum 350 mA cyclical overload and short-circuit protection
- Residual current: < 100 µA with transistor blocked
- Capacitance load:
 - maximum 0.5 µF at 55 V
 - maximum 1 µF at 24 V
- Residual voltage: < 3 V for transistor switched through

**3-wire electronic insert
FEI53**

Power supply

- Supply voltage: 14.5 V_{DC}
- Current consumption: < 15 mA
- Power consumption: maximum 230 mW
- Reverse polarity protection: yes
- Separation voltage: 0.5 kV

Electrical connection

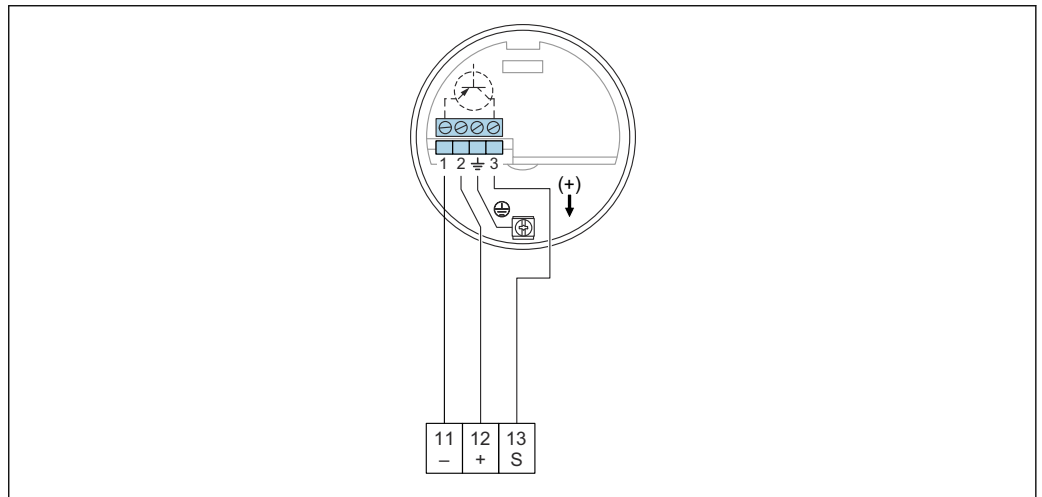

A0042389

- 11 The negative terminal in Nivotester FTC325
- 12 The positive terminal in Nivotester FTC325
- S Signal terminal in Nivotester FTC325

3 to 12 V signal.

For connecting to the switching unit, Nivotester FTC325 3-WIRE from Endress+Hauser.

Switching between minimum and maximum Safety in the Nivotester FTC325 3-WIRE.

Point level adjustment directly at the Nivotester.

Output signal

	GN	RD	→
			3 3 ... 12 V
			3 3 ... 12 V
			3 <2.7 V

A0042588

Signal on alarm

Voltage at terminal 3 opposite terminal 1: < 2.7 V

Connectable load

- Floating relay contacts in the connected switching unit Nivotester FTC325 3-WIRE
- For the contact load capacity, refer to the technical data of the switching device

AC and DC with relay output electronic insert FEI54**Power supply**

- Supply voltage:
 - 19 to 253 V_{AC} 50 to 60 Hz
 - 19 to 55 V_{DC}
- Power consumption: 1.6 W
- Reverse polarity protection: yes
- Separation voltage: 3.7 kV
- Overvoltage category: II

Electrical connection

 Please note the different voltage ranges for AC and DC.

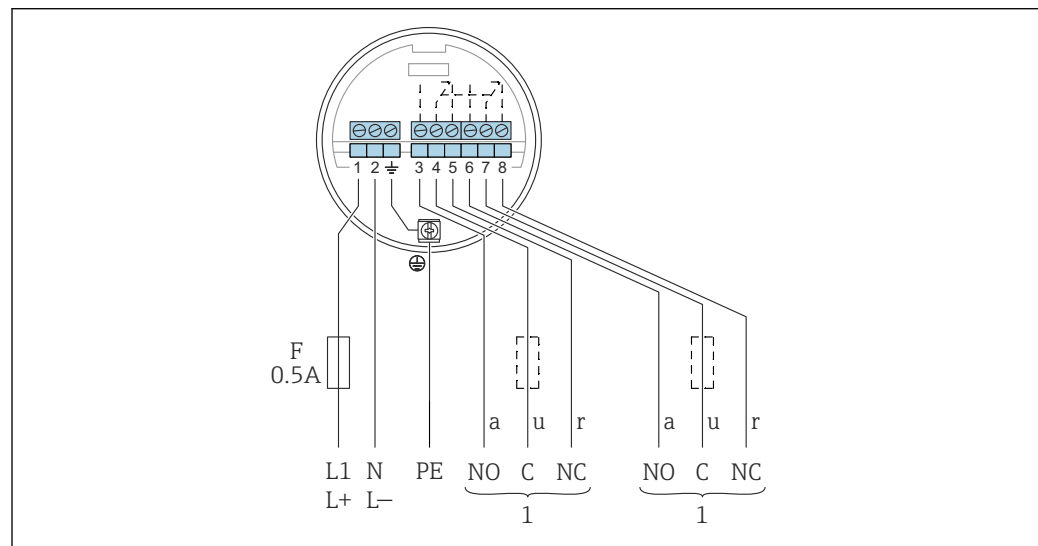

















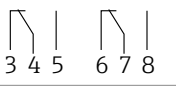







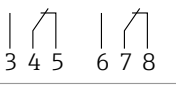







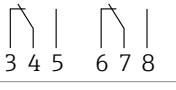







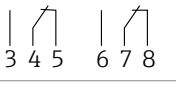





A0042390

- F* Fuse 0.5 A
L1 Phase (AC) terminal
L+ The positive (DC) terminal
N Neutral (AC) terminal
L- The negative (DC) terminal
PE Grounding cable
1 Refer also to connectable load

When connecting an instrument with high inductance, provide a spark arrester to protect the relay contact. A fine-wire fuse (depending on the load connected) protects the relay contact on short-circuiting. Both relay contacts switch simultaneously.

Output signal

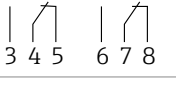
		GN	GN	RD	GN	GN	YE	
MAX								
								
MIN								
								
								
								

A0042528

Signal on alarm

Output signal on power failure or in the event of device failure: relay de-energized

Connectable load

- Loads switched via 2 floating changeover contacts (DPDT)
- maximum values (AC):
 - $I_{max} = 6 \text{ A}$
 - $U_{max} = 253 \text{ V}_{AC}$
 - $P_{max} = 1500 \text{ VA}$ at $\cos\varphi = 1$
 - $P_{max} = 750 \text{ VA}$ at $\cos\varphi > 0.7$
- maximum values (DC):
 - $I_{max} = 6 \text{ A}$ at 30 V_{DC}
 - $I_{max} = 0.2 \text{ A}$ at 125 V_{DC}
- The following applies when connecting a functional low-voltage circuit with double isolation as per IEC 1010:
 - sum of voltages of relay output and power supply maximum 300 V

SIL2 / SIL3 electronic insert
FEI55

Power supply

- Supply voltage: 11 to 36 V_{DC}
- Power consumption: < 600 mW
- Reverse polarity protection: yes
- Separation voltage: 0.5 kV

Electrical connection

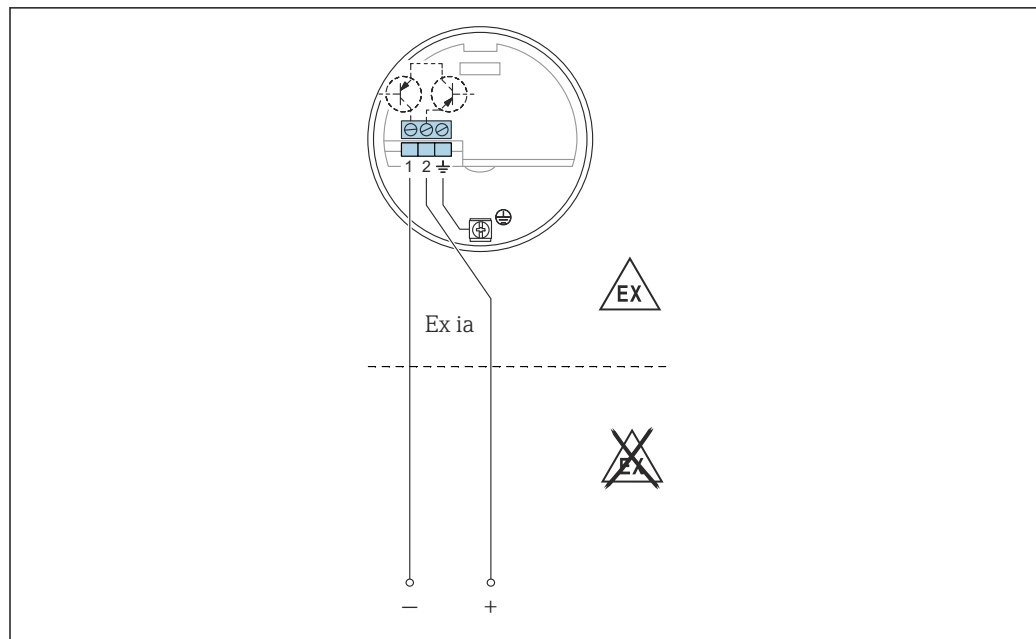

A0042391

Connect the insert to programmable logic controllers (PLC), AI modules 4 to 20 mA in accordance with EN 61131-2.

The point level signal is sent via an output signal jump from 8 to 16 mA.

Output signal

		GN	GN	RD	GN	GN	YE	
MAX								+ [2] $\xrightarrow{\sim 16 \text{ mA}}$ [1]
								+ [2] $\xrightarrow{\sim 8 \text{ mA}}$ [1]
MIN								+ [2] $\xrightarrow{\sim 16 \text{ mA}}$ [1]
								+ [2] $\xrightarrow{\sim 8 \text{ mA}}$ [1]
								+ [2] $\xrightarrow{\sim 8/16 \text{ mA}}$ [1]
								+ [2] $\xrightarrow{< 3.6 \text{ mA}}$ [1]

A0042529

Signal on alarm

Output signal on power failure or in the event of device failure: < 3.6 mA

Connectable load

- U:
 - 11 to 36 V_{DC} for non-hazardous area and Ex ia
 - 14.4 to 30 V_{DC} for Ex d
- I_{max} = 16 mA

PFM electronic insert FEI57S Power supply

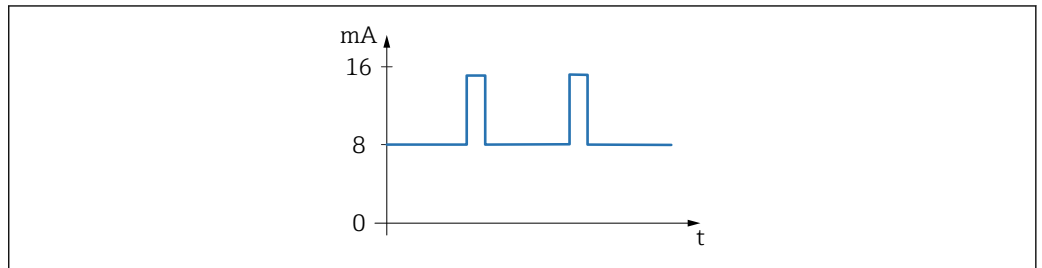

A0051934

35 PFM signal with frequency 17 to 185 Hz

- Supply voltage: 9.5 to 12.5 V_{DC}
- Power consumption: < 150 mW
- Reverse polarity protection: yes
- Separation voltage: 0.5 kV

Electrical connection

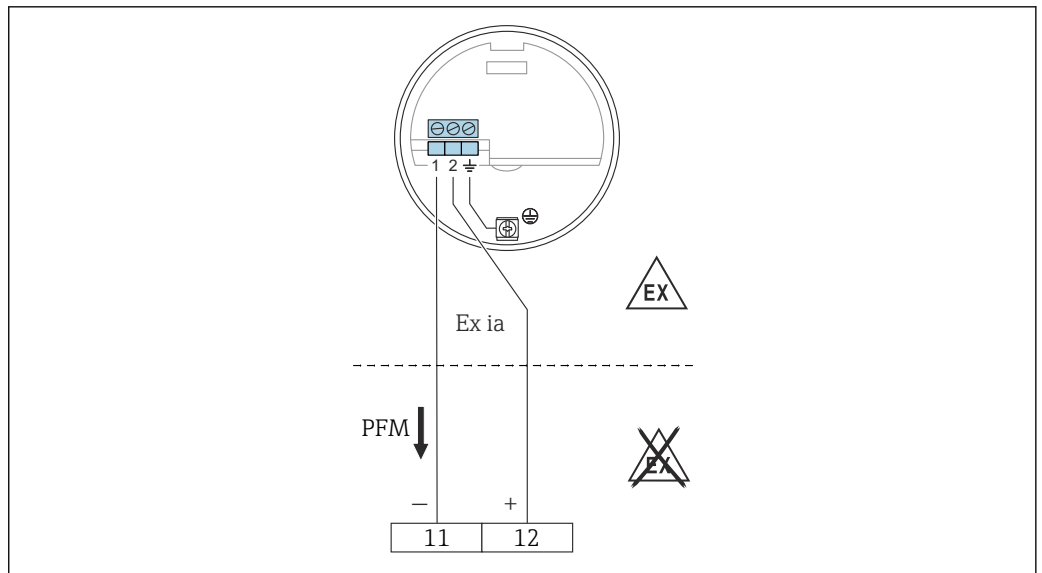

A0050141

- 11 The negative terminal in Nivotester FTC325
- 12 The positive terminal in Nivotester FTC325

For connecting to switching unit Nivotester FTC325 from Endress+Hauser.

PFM signal 17 to 185 Hz.

Switching between minimum and maximum safety in the Nivotester.

Output signal

PFM 60 to 185 Hz.

Signal on alarm

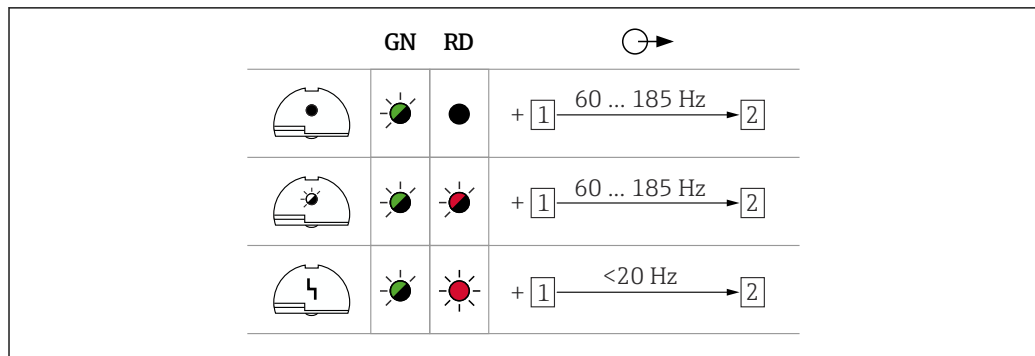

A0042589

Connectable load

- Floating relay contacts in the connected switching unit Nivotester: FTC325 PFM
- For the contact load capacity, refer to the technical data of the switching device.

NAMUR electronic insert
FEI58

Power supply

- Power consumption:
 - $< 6 \text{ mW}$ at $I < 1 \text{ mA}$
 - $< 38 \text{ mW}$ at $I = 2.2 \text{ to } 4 \text{ mA}$
- Interface connection data: IEC 60947-5-6

Electrical connection

-  In the case of Ex-d operation, the additional function can only be used if the housing is not exposed to an explosive atmosphere.

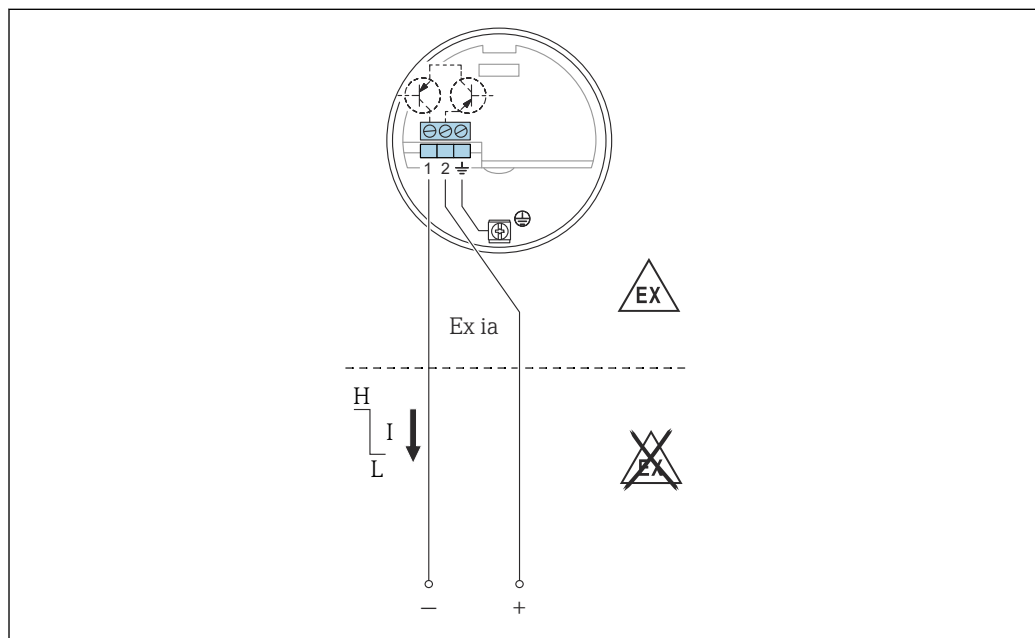

A0042393

 36 Terminals must be connected to isolating amplifier (NAMUR) IEC 60947-5-6

For connecting to isolating amplifiers as per NAMUR (IEC 60947-5-6), e.g. Nivotester FTL325N from Endress+Hauser. Change in output signal from high to low current in event of point level detection.

Additional function:

Test key on the electronic insert. Pressing the key interrupts the connection to the isolating amplifier.

Connection to Multiplexer:

Set 3 s as the cycle time at least.

Output signal

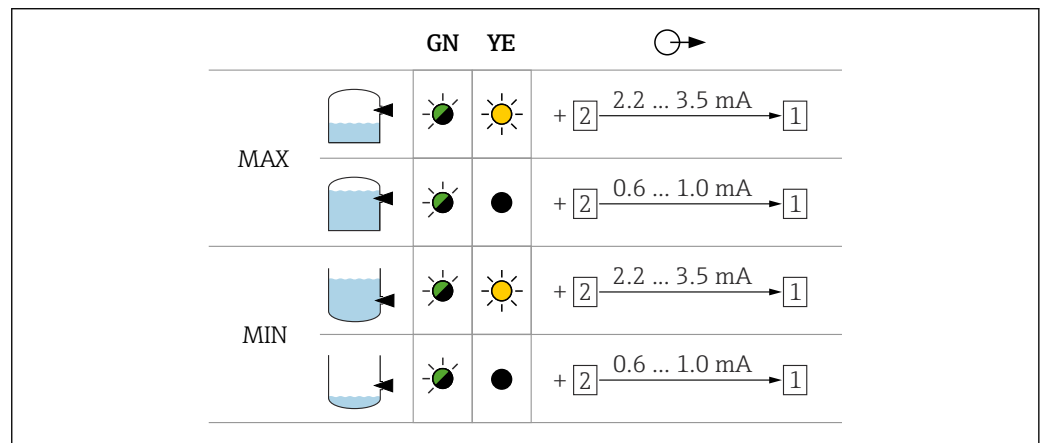

Signal on alarm

Output signal in the event of damage to the sensor: < 1.0 mA

Connectable load

- The technical data of the connected isolating amplifier as per IEC 60947-5-6 (NAMUR).
- Connection also to isolating amplifiers which have special safety circuits I > 3.0 mA.

Certificates and approvals

Current certificates and approvals for the product are available at www.endress.com on the relevant product page:

1. Select the product using the filters and search field.
2. Open the product page.
3. Select **Downloads**.

Other certificates and approvals for the product are available under <https://www.endress.com>-> Downloads.

Ordering information

Detailed ordering information is available from your nearest sales organization www.addresses.endress.com or in the Product Configurator at www.endress.com:

1. Select the product using the filters and search field.
2. Open the product page.
3. Select **Configuration**.



Product Configurator - the tool for individual product configuration

- Up-to-the-minute configuration data
- Depending on the device: Direct input of measuring point-specific information such as measuring range or operating language
- Automatic verification of exclusion criteria
- Automatic creation of the order code and its breakdown in PDF or Excel output format
- Ability to order directly in the Endress+Hauser Online Shop

Accessories

Protective cover

Protective cover for F13, F17 and F27 housing (without display)

order number: 71040497

Protective cover for F16 housing

order number: 71127760

Surge arresters

HAW562



- For supply lines: BA00302K.
- For signal lines: BA00303K.

HAW569



- For signal lines in field housing: BA00304K.
- For signal or supply lines in field housing: BA00305K.

Weld-in adapter

All available weld-in adapters are described in the document TI00426F.

The documentation is available in the Download section on Endress+Hauser web site: www.endress.com

Technical information

Nivotester FTC325

TI00380F

Documentation



- For an overview of the scope of the associated Technical Documentation, refer to the following:
- *Device Viewer* (www.endress.com/deviceviewer): Enter the serial number from the nameplate
 - *Endress+Hauser Operations app*: Enter serial number from nameplate or scan matrix code on nameplate.

Document function

The following documentation may be available depending on the version ordered:

Document type	Purpose and content of the document
Technical Information (TI)	<p>Planning aid for your device The document contains all the technical data on the device and provides an overview of the accessories and other products that can be ordered for the device.</p>
Brief Operating Instructions (KA)	<p>Guide that takes you quickly to the 1st measured value The Brief Operating Instructions contain all the essential information from incoming acceptance to initial commissioning.</p>
Operating Instructions (BA)	<p>Your reference document The Operating Instructions contain all the information that is required in the various phases of the life cycle of the device: from product identification, incoming acceptance and storage, to mounting, connection, operation and commissioning through to troubleshooting, maintenance and disposal.</p>
Description of Device Parameters (GP)	<p>Reference for your parameters The document provides a detailed explanation of each individual parameter. The description is aimed at those who work with the device over the entire life cycle and perform specific configurations.</p>
Safety Instructions (XA)	<p>Depending on the approval, safety instructions for electrical equipment in hazardous areas are also supplied with the device. The Safety Instructions are an integral part of the Operating Instructions.</p> <p> Information on the Safety Instructions (XA) relevant to the device is provided on the nameplate.</p>
Supplementary device-dependent documentation (SD/FY)	<p>Always comply strictly with the instructions in the relevant supplementary documentation. The supplementary documentation is an integral part of the device documentation.</p>



71673373

www.addresses.endress.com
