

# Technical Information

## JT33 TDLAS gas analyzer

Extractive TDLAS analyzer for reliable and accurate H<sub>2</sub>S measurements

For increased quality, process control, safety, and asset integrity



### Application

- H<sub>2</sub>S, LNG, NGL, refinery, biomethane, and carbon capture gas stream compositions
- Measurement ranges up to 500 ppmv

### Device Properties

- Compact controller with up to 3 I/Os
- Backlit display with touch control
- Web server interface for service and diagnostics
- With Class I, Division 1, and Ex approvals for use in hazardous areas Zone 1.

### Your benefits

- Reliable, accurate measurements
- Advanced diagnostics with Heartbeat Technology
- Tolerates contaminants and stream changes
- Proven performance
- Simple, intuitive user interface operation
- Verification report in a downloadable PDF
- Automatic validation for field measurement verification

## Table of Contents

<b>Introduction .....</b>	<b>3</b>	<b>Communications .....</b>	<b>16</b>
Document function .....	3	User interface .....	16
Symbols used .....	3	Heartbeat Technology .....	16
Standard documentation .....	3	Remote operation .....	17
Manufacturer address .....	3	Local operation .....	18
<b>Function and system design .....</b>	<b>4</b>	Service interface .....	19
Measuring principle .....	4	Supported operating tools .....	20
Differential TDLAS .....	6	HistoROM data management .....	21
WMS signal detection .....	7	<b>Certificates and approvals .....</b>	<b>23</b>
Measuring system .....	8	CE mark .....	23
Equipment architecture .....	9	Ex approval .....	23
Safety .....	9	CRN approval .....	23
Communications .....	10	Area classifications .....	23
<b>Installation .....</b>	<b>11</b>	<b>Ordering information .....</b>	<b>24</b>
Environment .....	11	Order codes .....	24
Dimensions .....	12	<b>Specifications .....</b>	<b>30</b>
Threaded entries .....	12	Gas specifications .....	30
Controller electrical connections .....	13	Technical data .....	33
Enclosure heater power .....	14		
Tubing connections .....	15		

## Introduction

**Document function** This Technical Information document contains information required to evaluate and specify the related equipment. A brief description of the installation and operation is also included. For additional operational instruction, see *Standard documentation* → .

**Symbols used** Informational symbol:

Symbol	Description
	Indicates additional information

**Standard documentation** All documentation is available:

- On the Endress+Hauser mobile app: [www.endress.com/supporting-tools](http://www.endress.com/supporting-tools)
- In the Downloads area of the Endress+Hauser website: [www.endress.com/downloads](http://www.endress.com/downloads)

This document is an integral part of the document package, which includes:

Part number	Document type	Description
BA02297C	Operating Instructions	A complete overview of the operations required to install, commission, and maintain the device
KA01655C	Brief Operating Instructions	Short instructions for standard installation and commissioning of the device
XA03137C	Safety Instructions	Requirements for installing or operating the analyzer as it relates to personnel or equipment safety
GP01198C	Description of device parameters	Reference for parameters, providing a detailed explanation of each individual parameter of the operating menu
SD02192C	Special Documentation Heartbeat Technology	Reference for using the Heartbeat Technology function integrated in the measuring device
SD03032C	Special Documentation Web server	Reference for using the web server integrated in the measuring device
SD03286C	Special Documentation	Validation of the J22 and JT33 TDLAS gas analyzer.
EA01426C	Installation Instructions	Installation instructions for the J22 and JT33 TDLAS gas analyzer firmware upgrade.

**Registered trademarks** **Modbus®**  
Registered trademark of SCHNEIDER AUTOMATION, INC.

**Manufacturer address** Endress+Hauser  
11027 Arrow Route  
Rancho Cucamonga, CA 91730  
United States  
[www.endress.com](http://www.endress.com)

## Function and system design

### Measuring principle

The JT33 operates in the near- to short-wavelength infrared. Each spectrometer consists of a tunable diode light source, sample cell, and detector specifically configured to enable high sensitivity measurement of a particular component within the presences of other gas phase constituents in the stream. The spectrometer is controlled by microprocessor-based electronics with embedded software that incorporates advanced operational and data processing algorithms.

### Sample conditioning system

A sample conditioning system (SCS) is offered with the JT33 TDLAS gas analyzer. The SCS has been specifically designed to deliver a sample stream that is representative of the process systems gas stream at the time of sampling. JT33 analyzers are designed for use with extractive gas sampling stations.

### How the analyzer works

The JT33 employs SpectraSensors tunable diode laser absorption spectroscopy (TDLAS) to detect the presence of hydrogen sulfide (H<sub>2</sub>S) in sample gases. Absorption spectroscopy is a widely used technique for sensitive trace species detection. Because the measurement is made without contacting the gas, the response is faster, more accurate, and significantly more reliable than traditional surface-based sensors that are subject to surface contamination.

In its simplest form, a diode laser absorption spectrometer consists of a sample cell with a mirror at one end, and a mirror or window at the opposite end, through which the laser beam can pass. The laser beam enters the cell and reflects off the mirrors, making multiple passes through the sample gas and eventually exiting the cell where the remaining beam intensity is measured by a detector. Sample gas flows continuously through the sample cell ensuring the sample is always representative of the flow in the main pipe.

Molecules in the sample gas each have characteristic absorption bands in the electromagnetic spectrum. When the output of the laser is tuned to a specific wavelength, the molecules with that particular absorption absorb energy from the incident beam. That is, as the beam of incident intensity,  $I_0(\lambda)$ , passes through the sample, attenuation occurs via absorption by the trace gas with absorption cross section  $\sigma(\lambda)$ . According to the Beer-Lambert absorption law, the intensity remaining,  $I(\lambda)$ , as measured by the detector at the end of the beam path of length  $l$ /(cell length x number of passes), is given by

$$I(\lambda) = I_0(\lambda)\exp[-\sigma(\lambda)lN]$$

where  $N$  represents the species concentration. Thus, the ratio of the absorption measured when the laser is tuned on-resonance versus off-resonance is directly proportional to the number of molecules of that particular species in the beam path, or

$$N = \frac{-1}{\sigma(\lambda)l} \ln \left[ \frac{I(\lambda)}{I_0(\lambda)} \right]$$

**Cutaway of JT33 TDLAS spectrometer**

The cutaway below shows the laser beam entering the cell and reflecting off the mirrors as the beam makes multiple passes through the sample gas.

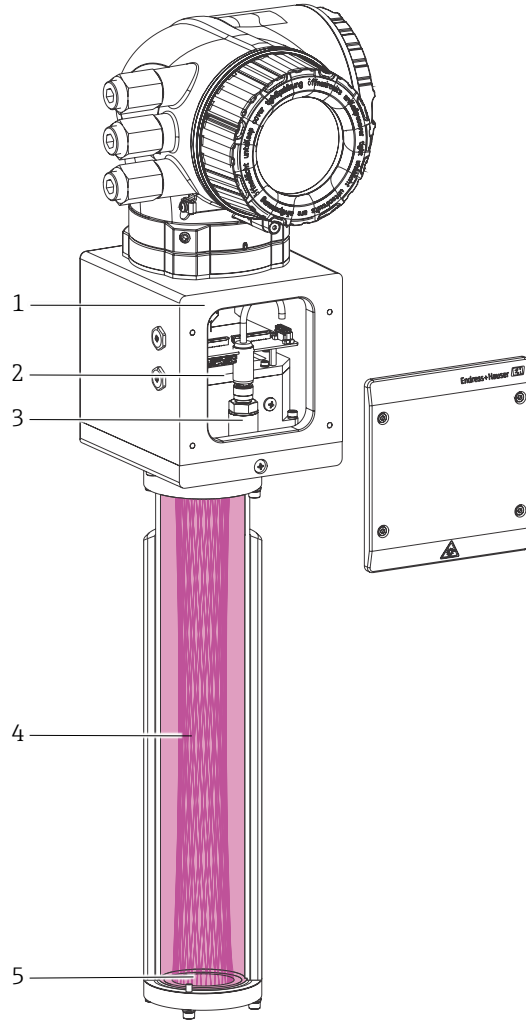

A0054820

Figure 1. Cutaway of JT33 TDLAS spectrometer

#	Description
1	Optical head
2	Laser and detector
3	Pressure sensor
4	Flow cell showing laser path (multi-pass)
5	Curved mirror

**Normalized absorption signal**

The figure below shows the typical, simplified raw data from a laser absorption spectrometer scan including the incident laser intensity,  $I_0(\lambda)$ , and the transmitted intensity,  $I(\lambda)$ . By normalizing the signal by the incident intensity, any laser output fluctuations are canceled and a typical, yet more pronounced absorption profile results.

Note that contamination of the mirrors results solely in lower overall signal. However, by tuning the laser off-resonance as well as on-resonance and normalizing the data, the technique self-calibrates every scan resulting in measurements that are unaffected by mirror contamination.

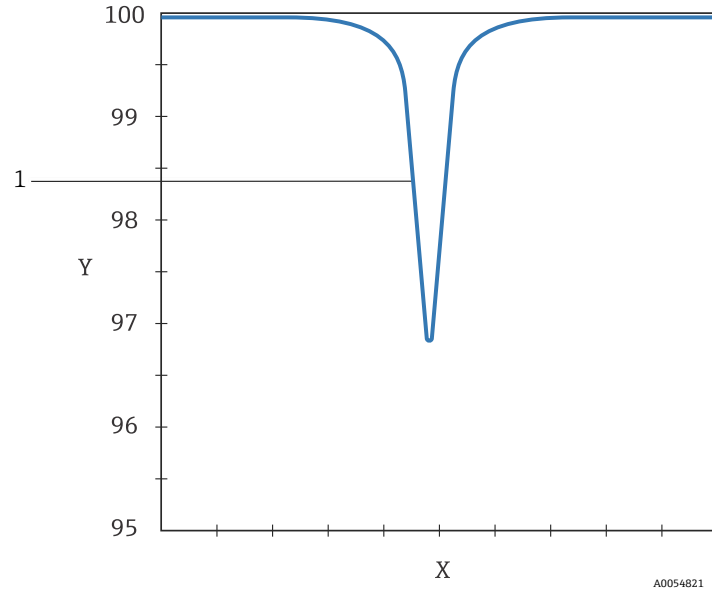

Figure 2. Typical normalized absorption signal from a laser diode absorption spectrometer

Item	Description
1	Normalized absorption signal
X axis	Wavelength [a.u.]
Y axis	Signal strength [ %]

**Differential TDLAS**

Similar to TDLAS, this technology involves subtracting 2 spectra from one another. A dry spectrum, a response from the sample when the analyte of interest has been completely removed, is subtracted from the wet spectrum, a response from the sample when the analyte is present. The remainder is a spectrum of the pure analyte. This technology is used to capture very low or trace measurements as well as when the background matrix changes over time.

**WMS signal detection**

Endress+Hauser takes the fundamental absorption spectroscopy concept a step further by using a sophisticated signal detection technique called wavelength modulation spectroscopy (WMS). When employing WMS, the laser drive current is modulated with a kHz sine wave as the laser is tuned rapidly. A lock-in amplifier is then used to detect the harmonic component of the signal that is at twice the modulation frequency ( $2f$ ), see the figure below. This phase-sensitive detection enables the filtering of low-frequency noise caused by turbulence in the sample gas, temperature or pressure fluctuations, low-frequency noise in the laser beam, or thermal noise in the detector.

With the resulting low-noise signal and the use of fast post-processing algorithms, reliable parts per million (ppm) detection levels are possible at real-time response rates (1 per second).

Measuring trace gases in various mixed hydrocarbon background streams is accomplished by selecting a different optimum diode laser wavelength between 700 to 3000 nm, which provides the least amount of sensitivity to background stream variations.

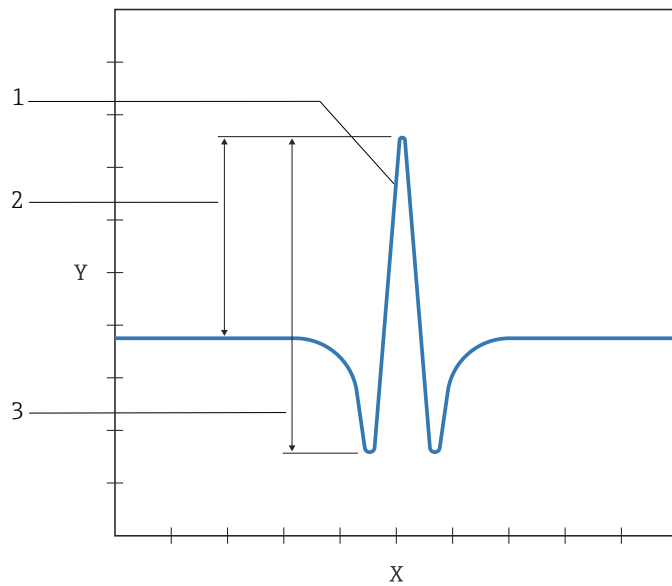

Figure 3. Simple normalized  $2f$  signal; analyte concentration proportional to the peak height or the peak-to-peak height, depending on the algorithm used

Item	Description
1	Normalized $2f$ spectrum
2	Peak height
3	Peak-to-peak height
X axis	Wavelength [a.u.]
Y axis	Transmission signal [a.u.]

**Measuring system**

The JT33 TDLAS gas analyzer is available in the configuration below.

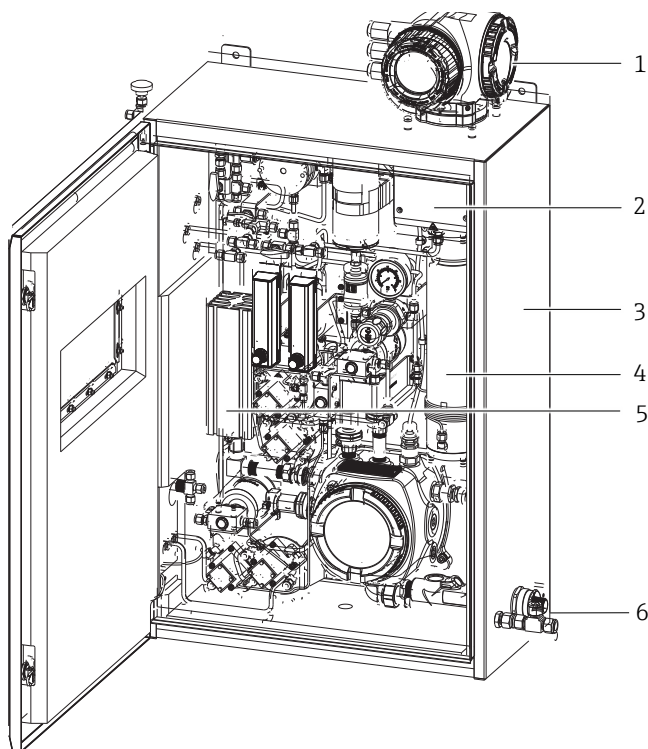

Figure 4. JT33 TDLAS gas analyzer system

#	Name	Description
1	Controller	Contains the power supply, HMI web server and 4-line backlit display, communications, and measurement control electronics
2	Optical head	Contains the laser, laser temperature control, detector, window, pressure and temperature sensors, and optical head electronics.
3	Enclosure	304 or 316 stainless steel enclosure, with or without a window; allows easy mounting to a wall or Unistrut frame; provides a protected environment for the SCS and spectrometer.
4	Sample cell and mirror	Sample gas flows through the cell by inlet and outlet ports. The laser beam passes through the cell multiple times while reflecting from the bottom mirror.
5	Heater system	Includes thermostat for condensation protection and temperature stabilization in colder weather; to reduce heat loss, the enclosure is insulated, including a heat trace boot for the gas inlet
6	Power input to SCS	The power for the SCS includes power for the heater and solenoid valves. The number of solenoid valves varies depending on the analyzer configuration.



Equipment architecture

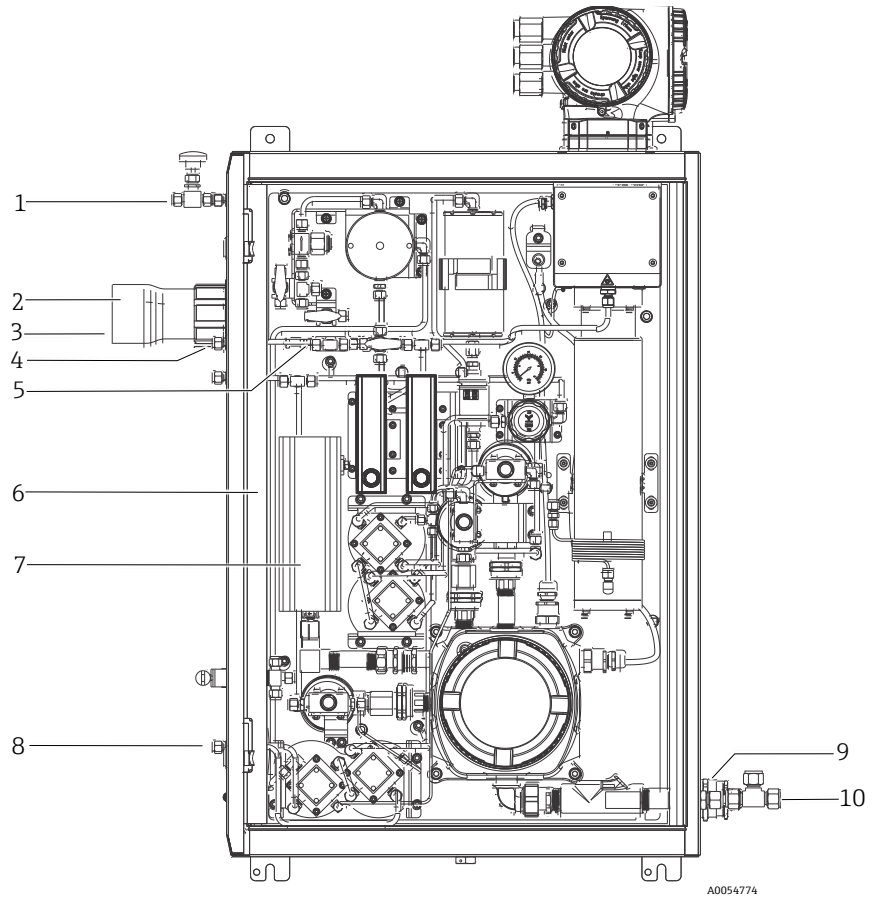

Figure 5. JT33 TDLAS gas analyzer with enclosed SCS, with heater

#	Description
1	Enclosure purge in/system purge in
2	Heat trace boot
3	Sample in
4	Sample vent, to safe area
5	Relief vent, factory set
6	Insulation, 5 walls plus door
7	Heater
8	Reference gas in
9	Power input
10	Enclosure purge out/test port

Safety

The JT33 offers a range of specific functions to support protective measures for the operator. These functions, if used correctly, can be configured by the user and will guarantee greater safety.

Function/Interface	Factory Setting	Recommendation
Write protection enabled with switch	Not enabled	Use on an individual basis following risk assessment.
Access code (also applies to web server log in)	Not enabled (0000)	Assign a custom access code during commissioning.
Web server	Enabled	On an individual basis following risk assessment.

**Protecting access with hardware write protection**

Write access to the device parameters using the local display. The web browser can be disabled with a write protection switch: DIP switch on the motherboard. When hardware write protection is enabled, only read access to the parameters is possible.

Hardware write protection is disabled by default from the factory.

**Protecting access with a password**

Different passwords are available to protect write access to the device parameters. The user-specific access code protects write access to the device parameters by the local display, such as web browser. Access authorization is regulated clearly through the use of a user-specific, modifiable access code.

**Access with web server**

The web server is enabled when the analyzer system is delivered. The web server can be disabled if necessary, such as after commissioning, by the web server functionality parameter.

The analyzer system and status information can be hidden on the log in page. This prevents unauthorized access to the data.

**Access with service interface (CDI-RJ45)**

The device can be accessed using the service interface (CDI-RJ45). Device-specific functions guarantee the secure operation of the JT33 in a network.

The use of relevant industrial standards and guidelines that have been defined by national and international safety committees, such as IEC/ISA62443 or the IEEE, is recommended. This includes organizational security measures such the assignment of access authorization as well as technical measures such as network segmentation.



Connection to the service interface (CDI-RJ45) shall only be permitted by trained personnel on a temporary basis for the purpose of test, repair, or overhaul of the equipment, and only if the area where the equipment is to be installed is known to be nonhazardous.

**Communications**

<b>Output type</b>	Modbus RS485 or Modbus TCP over Ethernet (I/O1)	$U_N = \text{DC } 30 \text{ V}$ $U_M = \text{AC } 250 \text{ V}$ $N = \text{nominal, } M = \text{maximum}$
	Relay output (I/O2 and/or I/O3)	$U_N = \text{DC } 30 \text{ V}$ $U_M = \text{AC } 250 \text{ V}$ $I_N = \text{DC } 100 \text{ mA/AC } 500 \text{ mA}$
	Configurable I/O <sup>1</sup> Current 4-20 mA I/O passive/active (I/O2 and/or I/O3)	$U_N = \text{DC } 30 \text{ V}$ $U_M = \text{AC } 250 \text{ V}$

<sup>1</sup> The configurable I/O can be configured by the HMI and web server interface, set as a 4-20 mA output to indicate concentration, cell temperature, pressure, or dew point temperature.

## Installation

### Environment

If operating outdoors:

- Install the measuring device in a shady location.
- Avoid direct sunlight, particularly in warm climatic regions.

### Readability of the local display

-20 to 60 °C (-4 to 140 °F)



The readability of the display may be impaired at temperatures outside the temperature range.

### Storage

- Select a storage location where moisture cannot collect in the JT33 controller or enclosure.
- If protection caps or protective covers are mounted, do not remove before installing the analyzer.

### Wall mounting

Mounting hardware used for the JT33 TDLAS gas analyzer must be able to support 4 times the weight of the instrument, approximately 89.9 kg (196 lb) to 102.5 kg (226 lb), depending on configuration. Refer to the *JT33 TDLAS gas analyzer Safety Instructions (XA03137C)* for installation-related safety information.

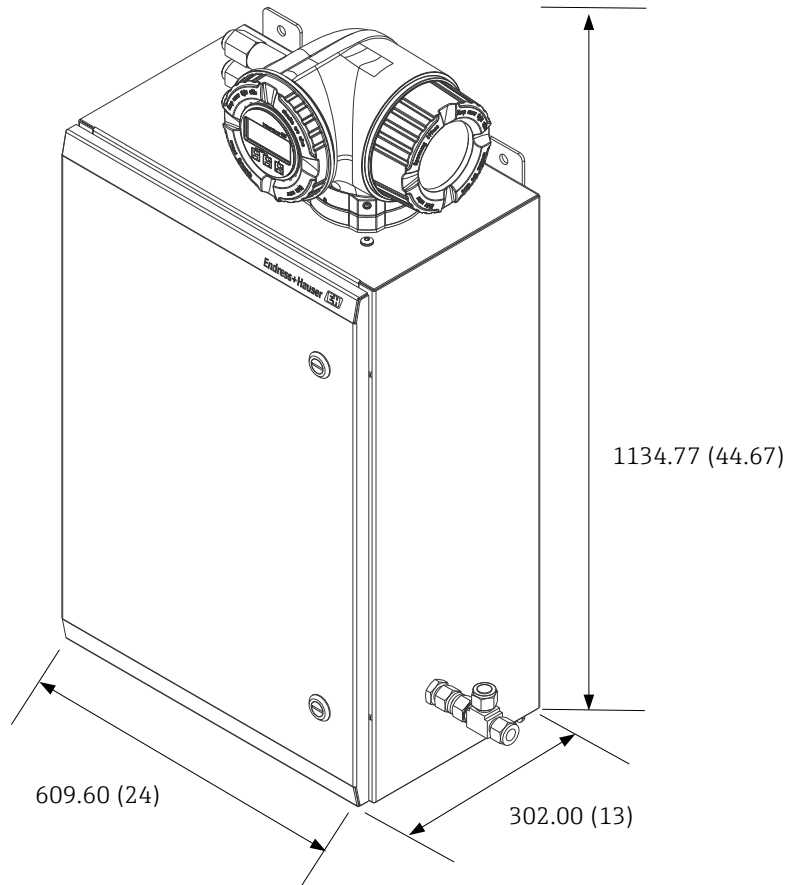

Figure 6. Slotted bottom mounting tabs



Figure 7. Top mounting tabs

**Dimensions**



A0054824

Figure 8. JT33 TDLAS gas analyzer with enclosed SCS. Dimensions: mm (in)

**Threaded entries**

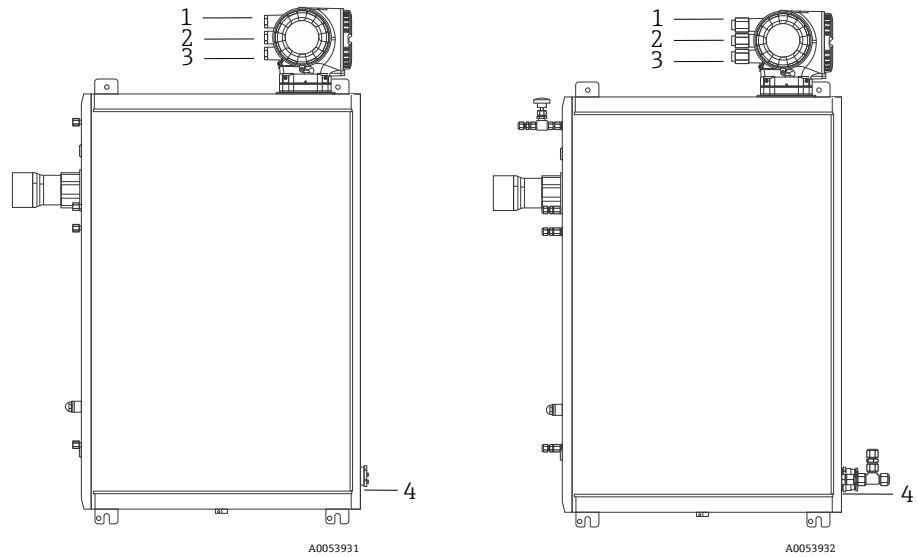
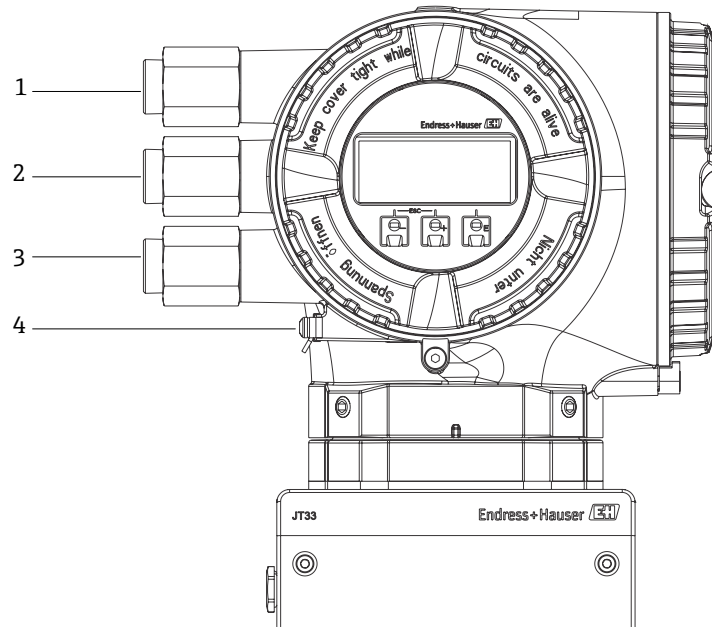

Figure 9. JT33 threaded entries on ATEX (left) and CSA (right) analyzer assemblies

Cable entry	Description	ATEX, IECEx, UKEx	cCSAus
1	Controller power	Female M20 x 1.5	½" NPTF
2	Modbus power	Female M20 x 1.5	½" NPTF
3	2 Configurable I/O	Female M20 x 1.5	½" NPTF
4	Measurement Accessory Controller (MAC) power	Male M25 x 1.5	¾" NPTM

**Controller electrical connections**



A0054799

Figure 10. Controller electrical connections

#	Description
1	Cable entry for supply voltage
2	Cable entry for signal transmission; I/O1, or Modbus RS485, or Ethernet network connection (RJ45)
3	Cable entry for signal transmission; I/O2, I/O3
4	Protective earth ground

## Enclosure heater power

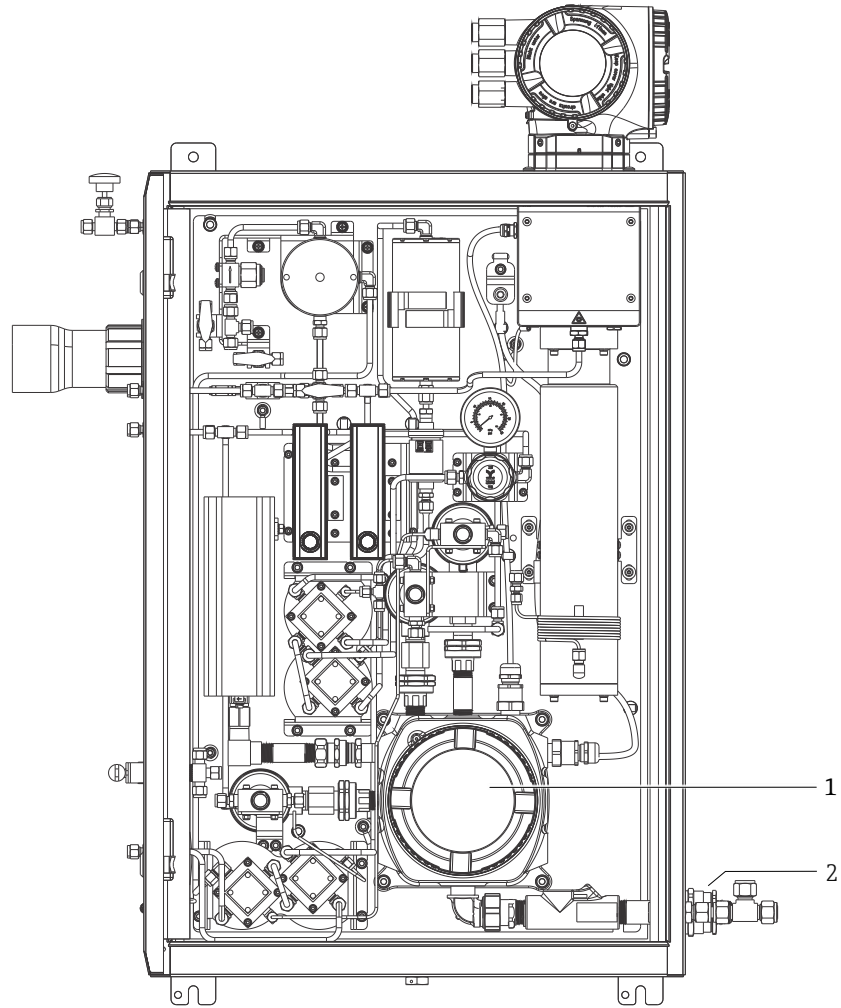

A0054774

Figure 11. Enclosure heater power

#	Description
1	MAC enclosure assembly, with power connection
2	Threaded entry for MAC power

**Tubing connections**

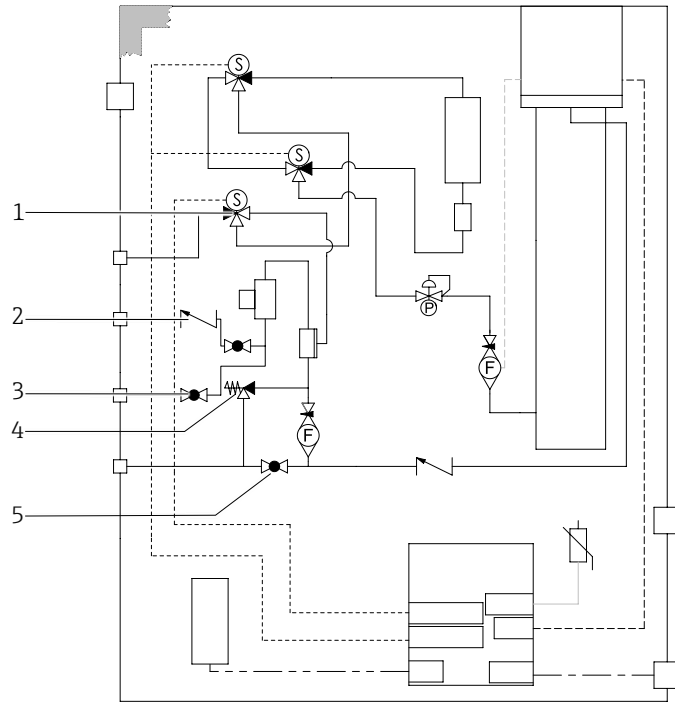

A0054804

Figure 12. Electrical differential with one point validation

#	Description
1	Validation inlet
2	Sample purge
3	Sample supply
4	Relief vent
5	System vent

## Communications

### User interface

Operator-oriented menu structure

- Commissioning
- Operation
- Diagnostics
- Expert level
- Validation

Fast and safe commissioning

- Guided menus and wizards for applications
- Menu guidance with brief descriptions of the individual parameter functions
- Access to the device using the web server

Reliable operation

- Uniform operating philosophy applied to device and operating tools
- If replacing electronic modules, transfer the device configuration using the integrated memory
- HistoROM backup, which contains the process and measuring device data and the event logbook
- No need to reconfigure

Increased measurement availability with efficient diagnostics

- Troubleshooting measures can be applied with the device and in the operating tools
- Varied simulation options, including event logbook and optional line recorder functions
- Auto-validation allows measurement verification against user-supplied gas standards.

### Heartbeat Technology

Package	Description
Heartbeat Verification + Monitoring	<p><b>Heartbeat Verification</b></p> <ul style="list-style-type: none"> <li>■ Traceable verification requirements met to DIN ISO 9001:2008 Chapter 7.6 a) "Control of monitoring and measuring equipment"</li> <li>■ Functional testing in the installed state without interrupting the process</li> <li>■ Traceable verification results report by request</li> <li>■ Simple testing process with local operation or other operating interfaces</li> <li>■ Clear measuring point pass/fail assessment with high test coverage within the framework of manufacturer specifications</li> <li>■ Extended calibration intervals according to operator's risk assessment</li> </ul> <p>Continuously supplies data, which are characteristic of the measuring principle, to an external condition monitoring system for monitoring preventive maintenance or process analysis. These data enable the operator to:</p> <ul style="list-style-type: none"> <li>■ Draw conclusions of the impact, using these data and other information</li> <li>■ Process the effect, such as corrosion, abrasion, and buildup, that influences have on the measurement performance over time</li> <li>■ Schedule service in a timely manner</li> <li>■ Monitor the process or product quality, such as gas pockets</li> </ul>



**Remote operation**

This communication interface is available in device versions with a Modbus RS485 output.

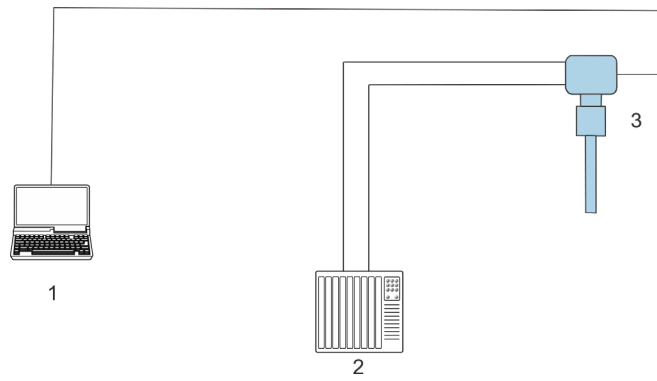

A0055166

Figure 13. Connecting through Modbus RS485 protocol (active)

#	Name
1	Computer with web browser, such as Internet Explorer, for temporarily accessing the device web server for settings and diagnostics
2	Automation/control system, such as PLC
3	JT33 TDLAS gas analyzer

This communication interface is available by Modbus TCP/IP network: star topology.

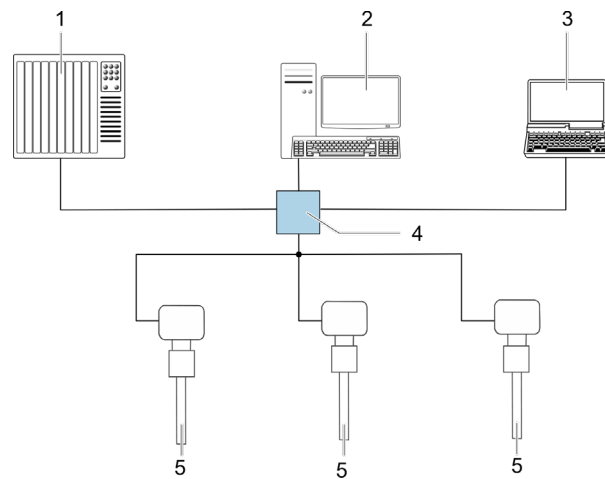

A0055167

Figure 14. Connecting through Modbus TCP protocol

#	Description
1	Automation/control system, such as PLC
2	Workstation for measurement operation
3	Computer with web browser for accessing the integrated device web server
4	Ethernet switch
5	JT33 TDLAS gas analyzer

## Local operation

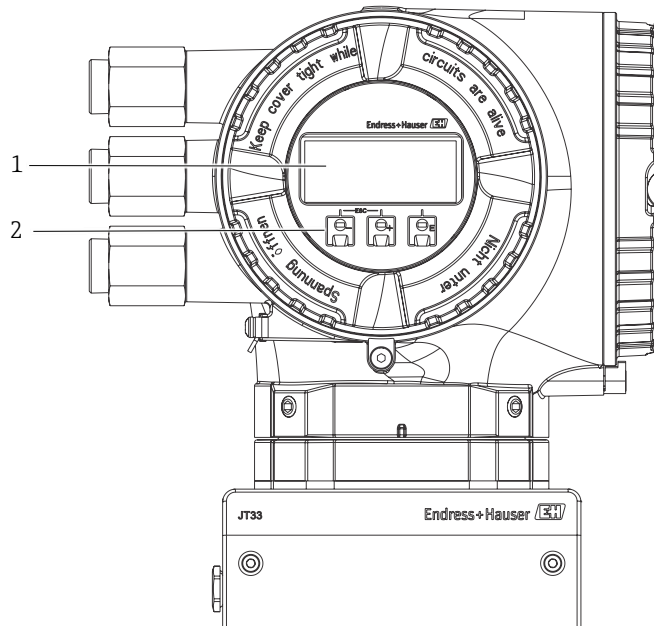

A0054799

Figure 15. Display module for local operation

#	Description
1	4-line backlit display
2	Through-glass optical keypad

### Display features

- 4-line illuminated, graphic display
- White background lighting; turns red to indicate a device error
- Configurable format for displaying measured variables and status variables
- Permitted ambient temperature for the display:  $-20$  to  $60$  °C ( $-4$  to  $140$  °F); potentially decreased display readability at temperatures outside the temperature range

### Operating features

- External operation with touch control (3 optical keys) without opening the housing
- Operating elements also accessible in hazardous areas

**Service interface**

**Service interface (CDI-RJ45)**

A temporary point-to-point connection can be established for on-site device configuration. With the housing open, the connection is established directly using the service interface (CDI-RJ45).

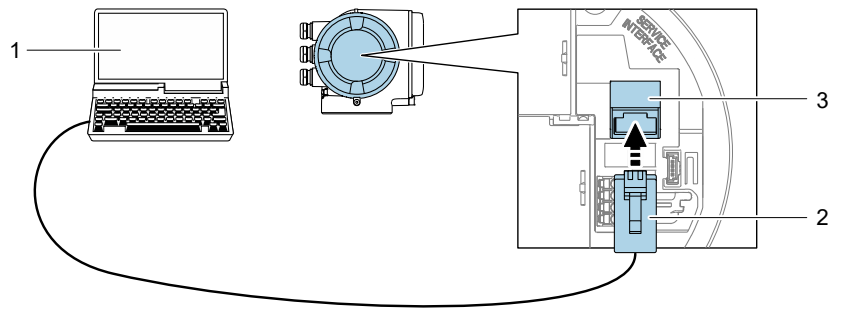

A0027563

Figure 16. Connection by service interface (CDI-RJ45)

#	Description
1	Computer with web browser, such as Internet Explorer or Microsoft Edge, for accessing the integrated device web server
2	Standard ethernet connecting cable with RJ45 connector
3	Service interface (CDI-RJ45) of the measuring device with access to the integrated web server

**Supported operating tools**

Different operating tools can be used for local or remote access to the measuring device. Depending on the tool used, access is possible with different operating units and through a variety of interfaces.

Supported operating tools	Operating unit	Interface	Additional information
Web browser	Notebook, PC, or tablet with web browser	CDI-RJ45 service interface	Special documentation for JT33

**Web server**

With the integrated web server, the device can be operated and configured using a web browser, service interface (CDI-RJ45), or a WLAN interface. The structure of the operating menu is the same as the local display. In addition to the measured values, status information on the device is also displayed, for easy monitoring. Device data and network parameters can also be managed.



Figure 17. Web browser user interface

#	Description
1	Function row
2	Local display language
3	Navigation area

**Supported functions**

Data exchange between the operating unit, such as a notebook, and the measuring device:

- Upload the configuration from the measuring device: XML format, configuration backup
- Save the configuration to the measuring device: XML format, restore configuration
- Export event list as a CSV file
- Export parameter settings as a CSV or PDF file; document the measuring point configuration
- Export the Heartbeat verification log
- Flash firmware version for device firmware upgrade, for example
- Download driver for system integration
- Visualize the saved measured values

**HistoROM data management**

The measuring device features HistoROM data management, which comprises both the storage and import/export of key device and process data. This ensures operation and servicing are far more reliable, secure, and efficient.



When the device is delivered, the factory settings of the configuration data are stored as a backup in the device memory. This memory can be overwritten with an updated data record, for example, after commissioning.

**Additional information on the data storage concept**

There are different types of data storage units in which device data are stored and used by the device.

	Device memory	T-DAT	S-DAT
Available data	<ul style="list-style-type: none"> <li>■ Event logbook for tracking diagnostic events</li> <li>■ Parameter data record backup</li> <li>■ Device firmware package</li> </ul>	<ul style="list-style-type: none"> <li>■ Measured value logging</li> <li>■ Current parameter data record, used by firmware at run time</li> <li>■ Maximum indicators (min/max values)</li> </ul>	<ul style="list-style-type: none"> <li>■ Sensor data</li> <li>■ Serial number</li> <li>■ Calibration data</li> <li>■ Device configuration, such as SW options, fixed I/O or multi I/O</li> </ul>
Storage location	Fixed on the user interface board in the connection compartment	Attachable to the user interface board in the connection compartment	Fixed in the optical head enclosure

**Data backup**

**Automatic**

- The most important device data—sensor and transmitter—are automatically saved in the DAT modules.
- If replacing the transmitter or measuring device: Once the T-DAT containing the previous device data has been exchanged, the new measuring device is ready for operation without any errors.
- If replacing the sensor: Once the sensor has been replaced, new sensor data are transferred from the S-DAT in the measuring device and the measuring device is ready for operation without any errors.
- If exchanging the electronics module, such as I/O electronics module: once the electronics module has been replaced, the software is compared against the current device firmware.  
The module software is upgraded or downgraded where necessary. The electronics module is available for use immediately afterwards without compatibility problems.

**Manual**

Additional customer-set parameter data record in the integrated device memory HistoROM backup for:

- Data backup function
- Backup and subsequent restoration of a device configuration in the device memory HistoROM backup
- Data comparison function: Comparison of the current device configuration with the device configuration saved in the device memory HistoROM backup

**Data Transfer**

Manual transfer of a configuration from one device to another using the export function of the specific operating tool, e.g., with web server: duplicate the configuration or store in an archive, such as for backup purposes.

**Event List**

- Automatic event tracking
- Data backup function
- Extended HistoROM application package gives chronological display of up to 100 event messages in the event list along with a time stamp, plain text description, and suggested remedial measures
- The event list can be exported and displayed in a variety of interfaces and operating tools, such as the web server, XLS and PDF.

**Data Logging**

Extended HistoROM application package gives manual tracking:

- Up to 1000 measured values recorded in 1 to 4 channels
- User-configurable recording interval
- Up to 250 measured values recorded with each of the 4 memory channels
- Export the measured value log in to a variety of export format web server.

## Certificates and approvals

**CE mark** The JT33 TDLAS gas analyzer meets the legal requirements described in Essential Health and Safety Requirements (EHSR) EU Directive 2014-34-EU and UK Statutory Requirements SI 2016 No.1107 (as amended) - Schedule 3A, Part 1. These are listed in the corresponding EU Declaration of Conformity along with the standards applied. Endress+Hauser confirms successful testing of the device by affixing to it the CE and UKCA mark.

**Ex approval** The measuring device is certified for use in potentially explosive atmospheres, and the relevant safety instructions are provided in the separate *JT33 TDLAS gas analyzer Safety Instructions (XA03137C)* manual. Reference is made to this document on the nameplate. The safety instructions containing all the relevant explosion protection data are available from the Endress+Hauser website.

**CRN approval** JT33 products may be specified with Canadian Registration Number (CRN) approval for both analyzer and sample system components. CRN-approved products are marked with a registration number.

**Area classifications**

Model	Certifications
JT33 TDLAS gas analyzer system	<p>cCSAus: Ex db ia [ia Ga] op is IIC T3 Gb                      Class I, Zone 1, AEx db ia [ia Ga] op is IIC T3 Gb                      [Ex ia] Class I, Division 1, Groups B, C, D, T3                      Tambient = -20 °C to 60 °C</p> <p>ATEX/IECEX/UKEX:  II 2(1)G                      Ex db ia [ia Ga] ib op is h IIC T3 Gb                      Tambient = -20 °C to 60 °C</p>
Ingress protection	Type 4X, IP66

## Ordering information

**Order codes**

Available order codes for the JT33 TDLAS gas analyzer are listed below. Refer to [www.endress.com/contact](http://www.endress.com/contact) to locate your local sales channel for more information.

Feature Number	Order Code	Description
Approval (Choose 1)		
10	BA	ATEX/UKEX + IECEX; Z1 2G ia ib IIC T3/T4 Gb
	CB <sup>2</sup>	cCSAus: [Ex ia] Cl.I Div. 1/Z1 [Ga] IIC T3/T4 Gb
	99	Special version, TSP – number to be specified
Analyte		
20	H <sub>2</sub> S	H <sub>2</sub> S measurement
H <sub>2</sub> S Measurement Range (Choose 1)		
30	A	0 to 10 ppm
	B	0 to 20 ppm
	C	0 to 50 ppm
	D	0 to 100 ppm
	E	0 to 500 ppm
	Y	Special version, TSP – number to be specified
H <sub>2</sub> O Measurement Range (Choose 1)		
40	N	None
	9	TSP – number to be specified
Additional Measurement Range		
50	N	None
O <sub>2</sub> Measurement Range (Choose 1)		
60	N	None
	Y	TSP – number to be specified

<sup>2</sup> CSA controller is shipped with plugged NPT adapters for power and I/O access.



Feature Number	Order Code	Description
Stream composition must be provided at time of order placement, except for option T01.		
70 <sup>3</sup>	T01	Natural gas, 90 % or more methane
	T02	Natural 50 % or more methane, 0 to 20 % ethane, 0 to 20 % CO2, 0 to 20 % N2
	T03	Natural gas, up to 50 % methane, 20 % ethane, and 50 % to 100 % CO2
	T22	NGL stream with 95 % or more ethane
	T23	NGL stream with 65 to 90 % ethane and 0 to 30 % propane
	T31	NGL Y-grade stream with 35 to 55 % ethane, 30 to 45 % propane, 0 to 20 % butanes and 0 to 6 % pentane+
	T32	NGL streams with 90 to 100 % propane, 0 to 8 % butanes
	T33	NGL stream with i-butanes 20 to 40 % and n-butane 55 to 90 %
	T42	NGL stream with up to 100 % propane and up to 100 % propylene
	T61	Gas stream with 70 to 90 % hydrogen, 8 to 20 % methane, 3 to 10 % ethane
	T62	Fuel or flare gas with 25 to 65 % H2, 15-55 % methane, 5 to 15 % ethane, 1 to 15 % propane, 1 to 15 % ethylene
	999	Special version, TSP – number to be specified
Venting to (Choose 1)		
80	A <sup>4</sup>	Atmosphere
	F <sup>5</sup>	Flare
Special Application (Choose 1)		
90	N	None
	Y	TSP – number to be specified
Measurement Wetted Materials (Choose 1)		
100	1 <sup>6</sup>	316 stainless steel; FKM seals
	9	Special version, TSP – number to be specified

<sup>3</sup> Stream composition must be provided upon order placement, except for option T01. Order will be delayed if stream composition is not provided.

<sup>4</sup> Venting to atmosphere means the analyzer can vent to pressures ranging from 800 to 1200 mbara (11.6 psia to 17.4 psia).

<sup>5</sup> Venting to flare means the analyzer can vent to pressures ranging from 800 to 1700 mbara (11.6 psia to 24.7 psia).

<sup>6</sup> FKM, also known as FPM, seals are a fluorinated, carbon-based synthetic rubber.

Feature Number	Order Code	Description
Power (Choose 1)		
110	A	AC 100 V to AC 240 V
	D <sup>7</sup>	DC 24 V
Output; Input 1 (Choose 1)		
120	1	Modbus RTU over RS485 (2-wire)
	2	Modbus TCP over Ethernet (RJ45)
Output; Input 2 (Choose 1)		
130 <sup>8</sup>	N	None
	1	Configurable I/O
	2	Relay Output
Output; Input 3 (Choose 1)		
140 <sup>8</sup>	N	None
	1	Configurable I/O
	2	Relay Output
Ambient Temperature (Choose 1)		
145 <sup>9</sup>	1 <sup>10</sup>	-20 to 50 °C (-4 to 122 °F)
	2 <sup>11</sup>	-10 to 60 °C (14 to 140 °F)
Controller Housing Material (Choose 1)		
150	1	Coated copper-free aluminum
	2	316 stainless steel
Controller Mounting (Choose 1)		
160	1	Fixed controller mount with integral HMI

<sup>7</sup> DC option is valid for controller power only. Sample conditioning system power is AC only. Refer to the technical data for detailed electrical specifications.

<sup>8</sup> Configurable I/O can be configured by customer for 4-20 mA input, output, or digital status/switch output.

<sup>9</sup> Identifying the operating/process gas temperature range allows the factory to make the correct heater settings for the analyzer sample conditioning system. For temperatures outside of these ranges, the analyzer should be installed in a temperature-stable shelter.

<sup>10</sup> The -20 to 50 °C option should be chosen when the analyzer is installed in temperate locations. It can also be selected when the analyzer is installed in cold regions where the temperature drops below 0° C; the lowest operational temperature is -20 °C.

<sup>11</sup> The -10 to 60 °C option should be chosen when the analyzer is installed in regions where the temperature ranges fluctuate up to 60 °C (such as the Middle East and India). It can also be selected when the analyzer is installed in regions where the temperature drops below 0 °C; the lowest operational temperature is -10 °C.

Feature Number	Order Code	Description
Sample Conditioning System and Enclosure (Choose 1)		
170	D	304 stainless steel
	E <sup>12</sup>	316 stainless steel
	H <sup>13</sup>	304 stainless steel, with window
	J <sup>12,13</sup>	316 stainless steel, with window
	Y	Special version; TSP – number to be specified
Validation Options (Choose 1)		
180 <sup>14</sup>	1 <sup>15</sup>	Manual validation
	2 <sup>16</sup>	Auto validation, 1-point
	4 <sup>16</sup>	Air operated auto validation, 1-point
	5 <sup>17</sup>	Air operated auto validation, 2-point
	Y	Special version; TSP – number to be specified
Filtration (Choose 1)		
190	A	Membrane separator with bypass
	N	None
	Y	Special version; TSP – number to be specified
Sample System Gas Connection (Choose 1)		
200	A	Imperial
	B <sup>18</sup>	Metric
	Y	Special version; TSP – number to be specified

<sup>12</sup> 316 stainless steel is available for offshore applications or installation locations in environments that cause corrosion.

<sup>13</sup> The window allows the customer to view the flowmeters, pressure regulator, and H<sub>2</sub>S indicator without opening the door and disturbing the heated system. This is useful for visually confirming that the flow rate of the flowmeters is correct, for viewing the pressure reading of the analyte being sent to the cell, and for checking the scrubber efficiency indicator for H<sub>2</sub>S contamination..

<sup>14</sup> A validation gas with a known amount of H<sub>2</sub>S in a carrier gas, such as nitrogen or methane, is used to validate that the analyzer is measuring correctly.

<sup>15</sup> Manual validation: The analyzer is supplied with a 3-way valve. Customers can connect the process gas and validation gas to the 3-way valve; gas inlet is switched from one to the other with a manual valve. The customer can add a padlock to lock out unexpected changes to the gas input.

<sup>16</sup> Auto-validation, 1-point with solenoid or pneumatic valve: An auto-validation cycle is initiated in the menu of the analyzer. A solenoid or pneumatic actuated valve is used to switch from the process gas to the validation gas.

<sup>17</sup> Auto-validation, 2-point with pneumatic valves: An auto-validation cycle is initiated in the menu of the analyzer. A pneumatic valve driven by air signals is used to switch from the process gas to the validation gas #1 and validation gas #2.

<sup>18</sup> When choosing the metric sample system gas connection option, imperial to metric conversion parts will ship in a separate package inside the analyzer crate.

Feature Number	Order Code	Description
Pressure Regulation (Choose 1)		
210	B	Pressure regulator plus pressure relief valve
	D <sup>19</sup>	Pressure regulator, premium, plus pressure relief valve
	Y	Special version; TSP – number to be specified (Must choose option D or Y when using Feature 590 option LS for CRN)
Flowmeter (Choose 1)		
220	F	Glass tube, factory default
	K	Glass tube, premium
	L <sup>20</sup>	Armored flowmeter, factory default
	M <sup>20</sup>	Armored Krohne flowmeter with Premium flow switches
	Y	Special version; TSP – number to be specified
Heating for Sample System (Choose 1)		
230 <sup>21</sup>	01 <sup>22</sup>	Heated, no heat-trace boot, AC 100 V
	02 <sup>22</sup>	Heated, with heat-trace boot, AC 100 V
	03	Heated, no heat-trace boot, AC 120 V
	04	Heated, with heat-trace boot, AC 120 V
	05	Heated, no heat-trace boot, AC 230 V
	06	Heated, with heat-trace boot, AC 230 V
	07	Heated, no heat-trace boot, AC 240 V
	08	Heated, with heat-trace boot, AC 240 V
	YY	Special version; TSP – number to be specified
Application-Specific Accessories		
240	A <sup>23</sup>	Safety purge for enclosed sample system (H <sub>2</sub> S > 300 ppm)
	N	None
	Y	Special version; TSP – number to be specified

<sup>19</sup> The premium pressure regulation option must be chosen when CRN is required.

<sup>20</sup> Option L or M must be chosen when CRN is required.

<sup>21</sup> A heated sample tube bundle is a prefabricated assembly designed to transport gas samples at a uniform temperature from the process sampling point to the inlet of the analyzer. A heat trace boot is used for connecting the sample tube to the analyzer. The heat trace boot option for the analyzer is the gas connection point to the analyzer. Various voltage options are available to suit different global area power requirements.

<sup>22</sup> Feature 170 options H and J (SCS and enclosure with a window) are not available with this option.

<sup>23</sup> A purge kit is required for applications where H<sub>2</sub>S concentration is higher than 300 ppm. The safety purge option for the enclosure includes 2 purges: 1 for the enclosure and 1 for the sample gas flow tubing.

Feature Number	Order Code	Description
Optional - Operating Language Display		
500	AA	English (default)
Optional – Alternative validation gas		
530 <sup>24</sup>	DM	100 % Methane (CH <sub>4</sub> )
	DN	100 % Nitrogen (N <sub>2</sub> )
	DC	100 % Carbon Dioxide (CO <sub>2</sub> )
	DY	Special version; TSP – number to be specified
Optional - Test, Certificate, Declaration		
580	JA	Inspection certificate 3.1, EN10204 (MTR)
	JB	NACE MR0175 / ISO 15156 + Inspection certificate 3.1, EN10204 (MTR)
	K9	Special version; TSP – number to be specified
Additional Approval (Optional)		
590	LS <sup>25</sup>	CRN
	L9	Special version; TSP – number to be specified
Marking (Optional)		
895	Z1	TAG
	Z9	Special version; TSP – number to be specified

<sup>24</sup> Analyzer setup from factory includes methane validation gas for natural gas streams and nitrogen for all other streams. Alternative validation gases change factory validation settings to customer preference.

<sup>25</sup> When choosing CRN approval for analyzer with sample conditioning system, the following components must be selected: A. Feature 10, option CB, B. Feature 210, option D, Feature 220, options L or M.

## Specifications

### Gas specifications

Component name	Chemical symbol	Natural gas streams (Feature 70)		
		Allowable component range <sup>26</sup>		
		Natural gas	Rich natural gas	Rich natural gas/Pure CO <sub>2</sub>
		Order code T01	Order code T02	Order code T03
		Application notes AI01217C/66, AI01304C, AI01303C, AI01251C, AI01246C, AI01255C	Application notes AI01217C/66, AI01304C, AI01303C, AI01251C, AI01246C, AI01255C	Application notes AI01217C/66, AI01361C
Methane	C <sub>1</sub>	90 to 100 %	50 to 100 %	0 to 50 %
Ethane	C <sub>2</sub>	0 to 7 %	0 to 20 %	0 to 20 %
Propane	C <sub>3</sub>	0 to 2 %	0 to 15 %	0 to 15 %
Butanes <sup>+</sup>	C <sub>4</sub>	0 to 1 %	0 to 5 %	0 to 5 %
Pentanes <sup>+</sup>	C <sub>5</sub>	0 to 0.2 %	0 to 2 %	0 to 2 %
Hexanes <sup>+</sup>	C <sub>6+</sub>	0 to 0.2 %	0 to 2 %	0 to 2 %
Carbon dioxide	CO <sub>2</sub>	0 to 3 %	0 to 20 %	50 to 100 %
Nitrogen and other inerts	N <sub>2</sub>	0 to 10 %	0 to 20 %	0 to 20 %
Hydrogen sulfide	H <sub>2</sub> S	0 to 300 ppmv	0 to 5 %	0 to 5 %
Water/moisture	H <sub>2</sub> O	0 to 5000 ppmv <sup>26</sup>	0 to 5000 ppmv <sup>26</sup>	0 to 5000 ppmv <sup>26</sup>

<sup>26</sup> For H<sub>2</sub>S measurements up to 50 ppmv, water content must be less than or equal to 5000 ppmv. For H<sub>2</sub>S measurements greater than 50 ppmv, water content must be less than 2%.

Component name	Chemical symbol	NGL streams (Feature 70)				
		Allowable component range				
		NGL ethane	NGL E/P mix	NGL Y-grade	NGL propane	NGL butane
		Order code T22	Order code T23	Order code T31	Order code T32	Order code T33
		Application note A101249C/66	Application note A101248C/66	Application note A101250C/66	Application note A101247C/66	---
Methane	C <sub>1</sub>	0 to 5 %	0 to 2 %	0 to 1.5 %	0 to 1 %	0 to 1 %
Ethane	C <sub>2</sub>	95 to 100 %	65 to 90 %	35 to 55 %	0 to 2 %	0 to 2 %
Propane	C <sub>3</sub>	0 to 3 %	0 to 30 %	30 to 45 %	90 – 100 %	0 to 3 %
Butanes <sup>+</sup>	C <sub>4</sub>	Sum of butanes and heavier components is 0 to 1 %	Sum of butanes and heavier components is 0 to 3 %	0 to 20 %	0 to 8 %	i-butane 20 to 40; n-butane 55 to 90
Pentanes <sup>+</sup>	C <sub>5</sub>	Sum of butanes and heavier components is 0 to 1 %	Sum of butanes and heavier components is 0 to 3 %	0 to 6 %	Sum of pentanes and hexanes and heavier components is 0 to 15 %	Sum of pentanes and hexanes and heavier components is 0 to 10 %
Hexanes <sup>+</sup>	C <sub>6+</sub>	Sum of butanes and heavier components is 0 to 1 %	Sum of butanes and heavier components is 0 to 3 %	---	Sum of pentanes and hexanes and heavier components is 0 to 15 %	Sum of pentanes and hexanes and heavier components is 0 to 10 %
Carbon dioxide	CO <sub>2</sub>	0 to 1 %	0 to 1 %	0 to 500 ppmv	200 ppmv	200 ppmv
Hydrogen sulfide	H <sub>2</sub> S	0 to 1 %	0 to 1 %	0 to 500 ppmv	0 to 100 ppmv	50 ppmv
Water/moisture	H <sub>2</sub> O	0 to 250 ppmv	0 to 250 ppmv	0 to 250 ppmv	50 ppmv	50 ppmv

Component name	Chemical symbol	Streams for refining and petrochemical applications (Feature 70)		
		Allowable component range		
		Propane/propylene mix	Hydrogen recycle	Fuel/flare gas
		Order code T42	Order code T61	Order code T62
		Application note AI01280C/66	Application notes AI01281C/66, AI01276C, AI01273C	Application notes AI01277C/66, AI01278C
Methane	C <sub>1</sub>	---	8 to 20 %	15 to 55 %
Ethane	C <sub>2</sub>	0 to 2 %	3 to 10 %	5 to 15 %
Propane	C <sub>3</sub>	0 to 100 %	0 to 5 %	1 to 15 %
Butanes <sup>+</sup>	C <sub>4</sub>	---	i-butanes 0 to 2 %; n-butane 0 to 2 %	i-butanes 0 to 5 %; n-butane 0 to 3 %
Pentanes <sup>+</sup>	C <sub>5</sub>	---	0 to 1 %	0 to 5 %
Carbon dioxide	CO <sub>2</sub>	---	---	0 to 5 %
Hydrogen sulfide	H <sub>2</sub> S	0 to 10 ppmv	---	0.5 to 300 ppmv
Water/moisture	H <sub>2</sub> O	0 to 10 ppmv	---	---
Oxygen	O <sub>2</sub>	---	---	0.1 to 5 %
Carbon monoxide	CO	---	---	0 to 5 %
Ethylene	C <sub>2</sub> H <sub>4</sub>	---	---	1 to 15 %
Propylene	C <sub>3</sub> H <sub>6</sub>	0 to 100 %	---	1 to 5 %
Hydrogen	H <sub>2</sub>	---	70 to 90 %	25 to 65 %



## Technical data

Measurement data	
Target component	H <sub>2</sub> S
Principle of measurement	Tunable diode laser absorption spectroscopy (TDLAS)
Measurement ranges	0 to 10 ppmv 0 to 500 ppmv Other ranges offered upon request
Repeatability	<b>Order codes T01 to T61:</b> ±100 ppbv or ±1 % of reading, whichever is greater <b>Order code T62:</b> ± 0.5 ppmv or ± 3 % of reading, whichever is greater
Accuracy	<b>Order codes T01 to T61:</b> ±200 ppbv or 3 % of reading, whichever is greater <b>Order code T62:</b> ± 1.5 ppm or 5 % of reading, whichever is greater
Limit of detection (LOD)	150 ppbv
Limit of quantification (LOQ)	500 ppbv
Application data	
Operational temperature	-20 to 50 °C (-4 to 122 °F) or -10 to 60 °C (14 to 140 °F)
Environmental temperature range	Storage: -40 to 60 °C (-40 to 140 °F) Ambient (T <sub>A</sub> ): -20 to 50 °C (-4 to 122 °F) Ambient (T <sub>A</sub> ): -20 to 60 °C (-4 to 140 °F)
Environment: pollution degree	Rated Type 4X and IP66 for outdoor use and is considered pollution degree 2 internally
Altitude	Up to 2000 m
Sample inlet pressure (SCS)	172 to 310 kPag (25 to 45 psig)
Sample cell operating pressure range	800 to 1200 mbar, standard 800 to 1700 mbar, optional
Sample flow rate	2.5 to 3 slpm (5.30 to 6.36 scfh)
Bypass flow rate	0.5 to 2.0 slpm (1 to 4.24 scfh)

Electrical and communication		
Controller display	4-line backlit display with touch control	
Controller operation	Configuration via display or web servers	
Controller housing materials	Copper-free aluminum with 60 to 150 mm polyester resin coating or cast stainless steel	
Input voltages: spectrometer	AC 100 to 240 V tolerance $\pm 10\%$ , 50/60 Hz, 10W <sup>27</sup> DC 24 V tolerance $\pm 20\%$ , 10W U <sub>M</sub> = AC 250 V	
Input voltages: SCS	AC 100 to 240 V $\pm 10\%$ , 50/60 Hz, 275W <sup>27</sup> U <sub>M</sub> = AC 250 V	
Ingress protection, analyzer and sample system	IP66, Type 4X	
Output type: spectrometer	Modbus RS485 or Modbus TCP over Ethernet (I/O1)	U <sub>N</sub> =DC 30 V U <sub>M</sub> =AC 250 V N=nominal, M = maximum
	Relay output (I/O2 and/or I/O3)	U <sub>N</sub> =DC 30 V U <sub>M</sub> =AC 250 V I <sub>N</sub> =DC 100 mA/AC 500 mA
	Configurable I/O Current 4-20 mA I/O passive/active (I/O2 and/or I/O3)	U <sub>N</sub> =DC 30 V U <sub>M</sub> =AC 250 V
	Intrinsically safe output (flow switch)	U <sub>o</sub> = Voc = $\pm 5.88$ V I <sub>o</sub> = Isc = 4.53 mA Po = 6.66 mW Co = Ca = 43 $\mu$ F Lo = La = 1.74 H

<sup>27</sup> Transient over-voltages according to Over Voltage Category II.

Electrical and communication		
Output type: SCS	Intrinsically safe output RS485 to optical head electronics (Manufacturer connection)	ATEX/IECEX/UKEX: J7 connector, Pin 1/Pin 2 w.r.t. enclosure earth  North America Zone/Division: J7 connector, Pin 1/Pin 2 w.r.t. enclosure ground/earth  $U_i = U_i/V_{max} = \pm 5.88 \text{ V}$ $I_i = I_i/I_{max} = -22.2 \text{ mA}$ , resistively limited by a minimum resistance $R_{min} = 265 \Omega$ $C_i = 0$ $L_i = 0$ $U_o = U_o/V_{oc} = 5.36 \text{ V}$ $I_o = I_o/I_{sc} = 39.7 \text{ mA}$ (resistively limited) $P_o = 52.9 \text{ mW}$
		Pin 1 w.r.t Pin 2  $U_i = U_i/V_{max} = \pm 11.76 \text{ V}$ $C_i = 0$ $L_i = 0$ $U_o = U_o/V_{oc} = \pm 5.36 \text{ V}$ $I_o = I_o/I_{sc} = \pm 10 \text{ mA}$ (resistively limited) $P_o = 13.3 \text{ mW}$
	Intrinsically safe output SCS thermistor	J5 connector $U_i/V_{max} = 0$ $U_o = V_{oc} = +5.88 \text{ V}, -1.0 \text{ V}$ $I_o = I_o/I_{sc} = 1.18 \text{ mA}$ (resistively limited) $P_o = 1.78 \text{ mW}$ $C_i = 0$ $L_i = 0$
	SCS heater output	$U_N = \text{AC } 100 \text{ to } 240 \text{ V } \pm 10 \%$ $U_M = \text{AC } 250 \text{ V}$ $I_N = \text{AC } 758 \text{ to } 2000 \text{ mA}$
	Output rating for solenoid valves	$U_N = \text{DC } 24 \text{ V}$ $U_M = \text{AC } 250 \text{ V}$ $I_N = 1 \text{ A contact rating}$ $P_{sov} = \leq 42 \text{ W}$

<b>Sample conditioning system (SCS)</b>	
Enclosure materials	Sample conditioning enclosure: 304 or 316 stainless steel Sample system panel: Anodized aluminum Enclosure window: Polycarbonate
Sample process temperature ( $T_P$ )	-20 to 60 °C (-4 to 140 °F)
Wetted materials including cell tube assembly	316L stainless steel FKM O-rings Glass PCTFE/PTFE
SCS components	Includes verification port and options for filtration, pressure regulation, flowmeters, flow switches, and safety purge. Also includes heater, solenoid and/or pneumatic valves, scrubber, and scrubber indicator.
<b>Certifications and Marks</b>	
	

[www.addresses.endress.com](http://www.addresses.endress.com)

---