

Technical Information

J22 TDLAS gas analyzer

extractive TDLAS analyzer for reliable and accurate measurements in Natural Gas stream compositions



Available with panel-mounted sample conditioning systems and enclosed, heated sample systems

With Class I, Division 1 and Ex approvals for use in hazardous areas Zone 1.

Application

- H₂O in Natural Gas
- Measurement ranges up to 6000 ppmv

Device Properties

- Compact controller with up to (3) I/Os
- Backlit display with touch control
- Web server interface for service and diagnostics

Your benefits

- Reliable, accurate measurements
- Advanced diagnostics with Heartbeat Technology
- Proven technology
- Intuitive and easy user interface operation
- Downloadable PDF verification report



Table of contents

Introduction	3	Communications.....	19
Document function	3	User interface	19
Symbols used	3	Heartbeat Technology	19
Manufacturer address	4	Local operation.....	20
Function and System Design.....	5	Remote operation.....	21
Measuring principle.....	5	Service interface.....	22
WMS signal detection	8	Supported operating tools.....	22
Measuring system.....	9	HistoROM data management	23
Equipment architecture.....	11	Certificates and approvals.....	25
Safety	12	CE mark.....	25
Communications	13	Ex approval	25
Installation	14	CRN approval.....	25
Environment.....	14	Area classifications	25
Dimensions.....	15	Ordering Information.....	27
Threaded cable entries	17	Order codes	27
Electrical connections.....	17	Gas specifications.....	30
Tubing connections.....	18	Technical data	31

Introduction

Document function This Technical Information document contains information required to evaluate and specify the related equipment. A brief description of the installation and operation are also included. Additional information is available for operational instruction. See *Standard Documentation*.

Symbols used

Informational symbols

Symbol	Description
	Indicates additional information

Documentation

All documentation is available:

- On the USB provided with the analyzer
- On the website: www.endress.com

Each analyzer shipped from the factory is packaged with documents for the model that was purchased. This document is an integral part of the complete document package, which includes:

Part Number	Document Type	Description
XA02708C	Safety Instructions	Requirements for installing or operating the J22 related to personnel or equipment safety.
XA03086C	Safety Instructions	Requirements for installing or operating the J22 TDLAS gas analyzer related to personnel or equipment safety for INMETRO (Brazil) certification.
XA03087C	Safety Instructions	Requirements for installing or operating the J22 TDLAS gas analyzer related to personnel or equipment safety for CML (Japan) certification.
XA03090C	Safety Instructions	Requirements for installing or operating the J22 TDLAS gas analyzer related to personnel or equipment safety for KC: ATEX/IECEX Zone 1 certification.
XA03211C	Safety Instructions	Requirements for installing or operating the J22 TDLAS gas analyzer related to personnel or equipment safety for PESO: ATEX/IECEX Zone 1 certification (for India).
BA02152C	Operating Instructions	A complete overview of the operations required to install, commission and maintain the device.
GP01198C	Device Parameters	Reference for parameters, providing a detailed explanation of each individual parameter of the operating menu.
SD03286C	Special Documentation	Description, guidelines, and procedure for validation of TDLAS gas analyzers.
EA01501C	Installation Instructions	Instructions for replacing measurement components for the J22 TDLAS gas analyzer.
EA01426C	Installation Instructions	Installation instructions for the J22 and JT33 TDLAS gas analyzer firmware upgrade.
EA01507C	Installation Instructions	Installation instructions for replacing the J22 and JT33 TDLAS gas analyzer electronics and display.

Registered trademarks

Modbus® Registered trademark of SCHNEIDER AUTOMATION, INC.

HistoROM®, Heartbeat Technology™ Registered or registration-pending trademarks of the Endress+Hauser Group

Manufacturer address

Endress+Hauser
11027 Arrow Route
Rancho Cucamonga, CA 91730
United States
www.endress.com

Function and System Design

Measuring principle

The J22 operates in the near to short-wavelength infrared. Each spectrometer consists of a tunable diode light source, sample cell and detector specifically configured to enable high sensitivity measurement of a particular component within the presences of other gas phase constituents in the stream. The spectrometer is controlled by microprocessor-based electronics with embedded software that incorporates advanced operational and data processing algorithms.

Sample conditioning system

A sample conditioning system (SCS) is optional with the J22 TDLAS gas analyzer. The SCS has been specifically designed to deliver a sample stream that is representative of the process systems stream at the time of sampling. J22 analyzers are designed for use with extractive natural gas sampling stations.

How the analyzers work

The J22 employs SpectraSensors tunable diode laser spectroscopy (TDLAS) to detect the presence of water (H₂O) in sample gases. Absorption spectroscopy is a widely used technique for sensitive trace species detection. Because the measurement is made without contacting the gas, the response is much faster, more accurate and significantly more reliable than traditional surface-based sensors that are subject to surface contamination.

In its simplest form, a diode laser absorption spectrometer consists of a sample cell with a mirror at one end, and a mirror or window at the opposite end, through which the laser beam can pass *Cutaway of J22 TDLAS gas analyzer spectrometer*. The laser beam enters the cell and reflects off the mirror(s) making multiple passes through the sample gas and eventually exiting the cell where the remaining beam intensity is measured by a detector. Sample gas flows continuously through the sample cell ensuring that the sample is always representative of the flow in the main pipe.

Molecules in the sample gas each have characteristic absorption bands in the electromagnetic spectrum. When the output of the laser is tuned to a specific wavelength, the molecules with that particular absorption will absorb energy from the incident beam. That is, as the beam of incident intensity, $I_0(\lambda)$, passes through the sample, attenuation occurs via absorption by the trace gas with absorption cross section $\sigma(\lambda)$. According to the Beer-Lambert absorption law, the intensity remaining, $I(\lambda)$, as measured by the detector at the end of the beam path of length l (cell length x number of passes), is given by

$$I(\lambda) = I_0(\lambda) \exp[-\sigma(\lambda)lN],$$

where N represents the species concentration. Thus, the ratio of the absorption measured when the laser is tuned on-resonance versus off-resonance is directly proportional to the number of molecules of that particular species in the beam path, or

$$N = \frac{-1}{\sigma(\lambda)l} \ln \left[\frac{I(\lambda)}{I_0(\lambda)} \right].$$

Cutaway of J22 TDLAS spectrometer

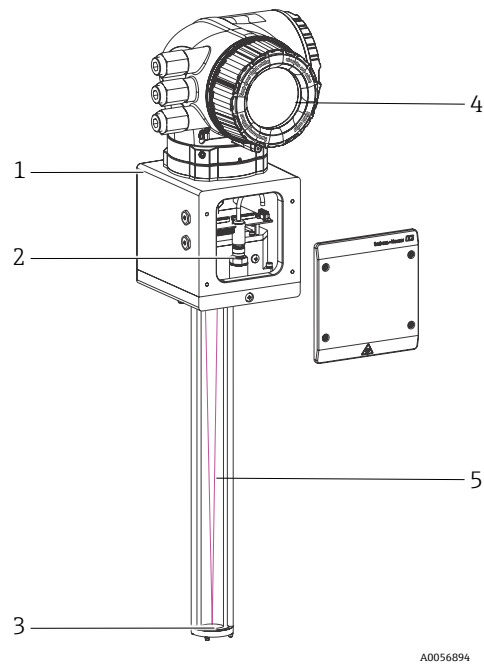

A0056894

Figure 1. Cutaway of J22 TDLAS gas analyzer spectrometer

#	Description
1	Optical head (the laser, detector and TEC are housed behind the optical window)
2	Pressure and temperature sensor
3	Curved mirror
4	User interface
5	Flow cell showing laser path (2-pass)

Normalized absorption signal

The figure below shows the typical raw data (simplified) from a laser absorption spectrometer scan including the incident laser intensity, $I_0(\lambda)$, and the transmitted intensity, $I(\lambda)$. By normalizing the signal by the incident intensity, any laser output fluctuations are canceled and a typical, yet more pronounced, absorption profile results.

Note that contamination of the mirrors results solely in lower overall signal. However, by tuning the laser off-resonance as well as on-resonance and normalizing the data, the technique self-calibrates every scan, resulting in measurements that are unaffected by mirror contamination.

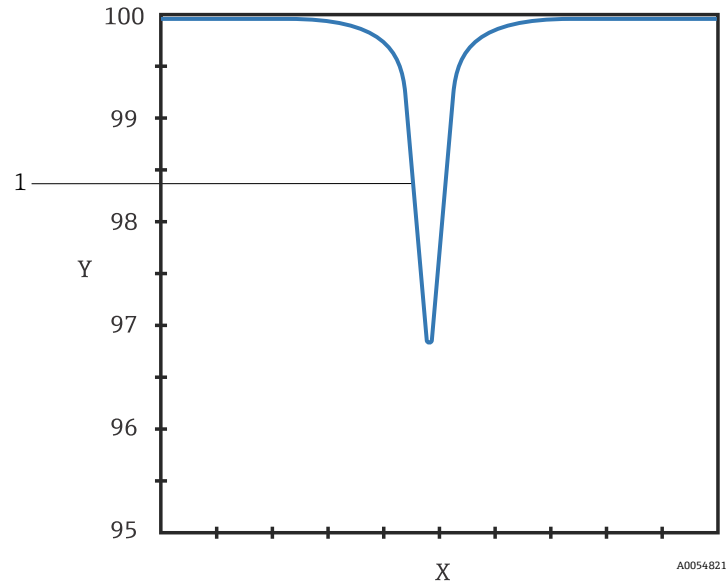

Figure 2. Typical normalized absorption signal from a laser diode absorption spectrometer

Item	Description
1	Normalized absorption signal
X axis	Wavelength [a.u.]
Y axis	Signal strength [%]

WMS signal detection

Endress+Hauser takes the fundamental absorption spectroscopy concept a step further by using a sophisticated signal detection technique called wavelength modulation spectroscopy (WMS). When employing WMS, the laser drive current is modulated with a kHz sine wave as the laser is rapidly tuned. A lock-in amplifier is then used to detect the harmonic component of the signal that is at twice the modulation frequency ($2f$). This phase-sensitive detection enables the filtering of low-frequency noise caused by turbulence in the sample gas, temperature and/or pressure fluctuations, low-frequency noise in the laser beam or thermal noise in the detector.

With the resulting low-noise signal and use of fast post-processing algorithms, reliable parts per million (ppm) detection levels are possible at real-time response rates (on the order of 1 second).

Measuring trace gases in varying mixed hydrocarbon background streams is accomplished by selecting a different optimum diode laser wavelength between 700-3000 nm, which provides the least amount of sensitivity to background stream variations.

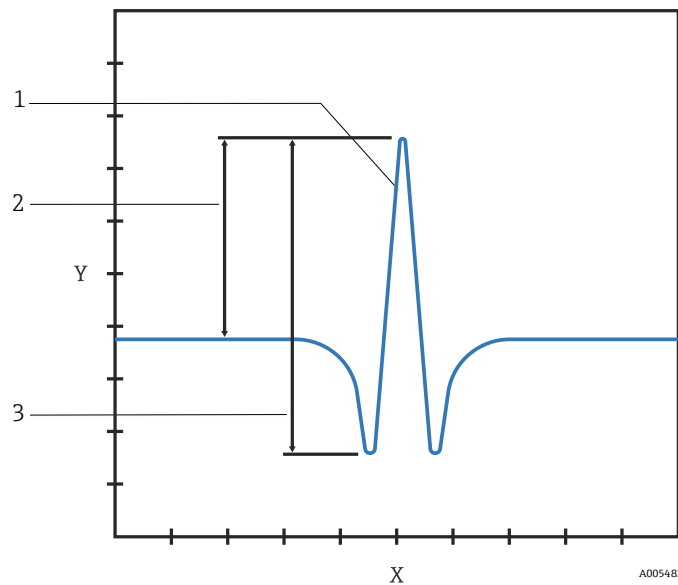

Figure 3. Simple normalized $2f$ signal; analyte concentration proportional to the peak height or the peak-to-peak height, depending on the algorithm used

Item	Description
1	Normalized $2f$ spectrum
2	Peak height
3	Peak-to-peak height
X axis	Wavelength [a.u.]
Y axis	Transmission signal [a.u.]

Measuring system

The J22 is offered as a stand-alone analyzer or accompanied by a sample conditioning system on a panel or in an enclosure.

J22 TDLAS gas analyzer

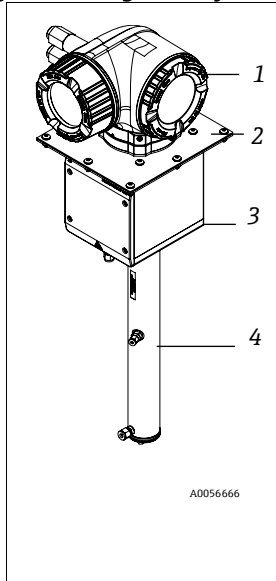

The base analyzer consists of:

1. Controller
Contains the power supply, HMI (Web server and 4-line back-lit display), communications and measurement control electronics.
2. Mounting plate
Optional mounting plate for customer installation into top-mount enclosure applications.
3. Optical head
Contains the laser, laser temperature control, detector, window, pressure and temperature sensors, optical head electronics.
4. Sample cell and mirror
Sample gas flows through the cell via an inlet and outlet port. The laser beam passes through the cell, reflecting once from the flat mirror on the bottom.

J22 TDLAS gas analyzer with SCS on panel

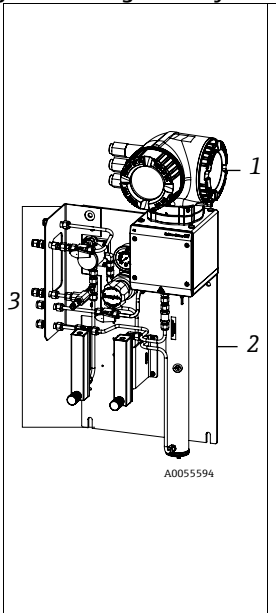

The analyzer system on a panel consists of the following and is designed for exterior mounting near the sample extraction point or inside a shelter.

1. J22 TDLAS gas analyzer
See description above.
2. Anodized aluminum panel
(Other materials can be special ordered)
Allows easy mounting to a wall, Unistrut frame, or post and provides a mounting surface of the sample conditioning components
3. Sample conditioning components
Components used to filter the gas while maintaining a representative sample and control the pressure and flow. An optional bypass is available as a speed loop and to continually sweep the dirty side of the membrane separator (→ 34).

**J22 TDLAS gas analyzer with enclosed SCS,
J22 TDLAS gas analyzer with enclosed SCS, with heater**

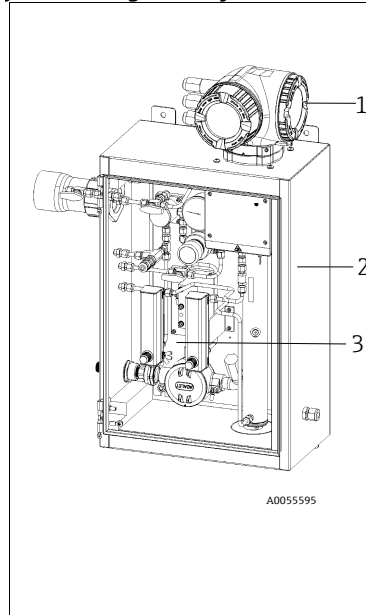

The enclosed analyzer system with optional heater consists of the following and is typically used for exterior mounting near the sample extraction point.

1. J22 TDLAS gas analyzer
See description above.
2. 304 stainless steel enclosure
(Other materials can be special ordered)
Allows easy mounting to a wall, Unistrut frame, or a post and provides a protected environment for the SCS and spectrometer.
3. Heater system (optional)
Includes an 80-watt heater with thermostat for condensation protection and stable temperatures in colder weather. When a heater is employed, the enclosure will be outfitted with insulation to reduce heat loss and a heat trace boot for the gas inlet.

Equipment architecture

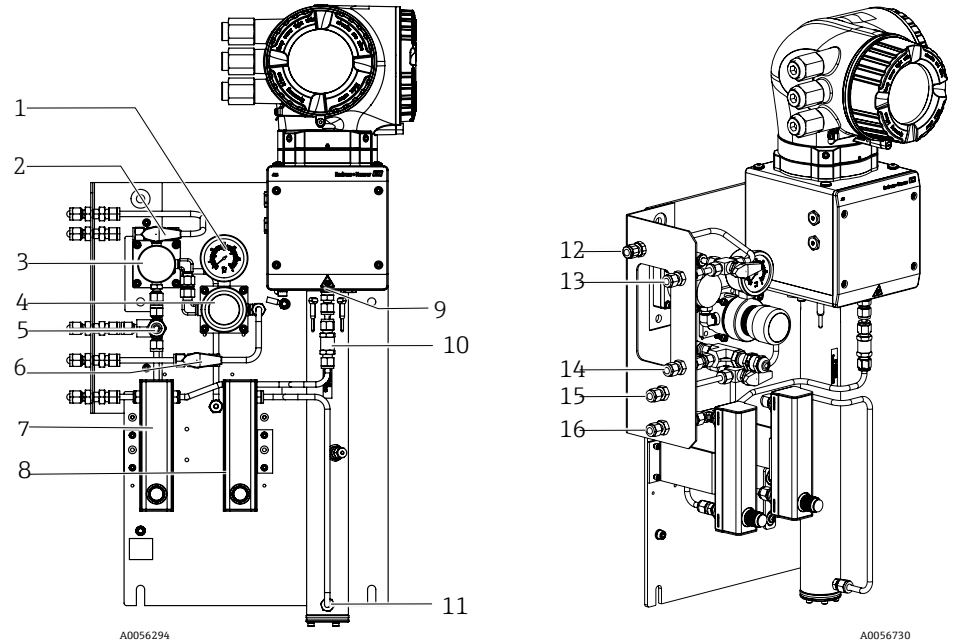

Figure 4. J22 TDLAS gas analyzer with SCS on panel - sample system and gas connections

- | | |
|---|--|
| 1 Pressure gauge | 12 Sample purge in, 140-310 kPa (20-45 psi) (optional) |
| 2 Gas select valve (purge in/sample in) | 13 Sample in, 140-310 kPa (20-45 psi) |
| 3 Membrane separator (optional) | 14 Relief vent, factory set, 350 kPa (50 psig) to safe area (optional) |
| 4 Pressure regulator | 15 Reference gas in, 15-70 kPa (2-10 psi) |
| 5 Pressure relief valve (optional) | 16 Sample vent, to safe area |
| 6 Reference gas on / off | |
| 7 Flow meter for bypass (optional) | |
| 8 Flow meter for analyzer | |
| 9 Cell outlet port | |
| 10 Check valve (optional) | |
| 11 Cell inlet port | |

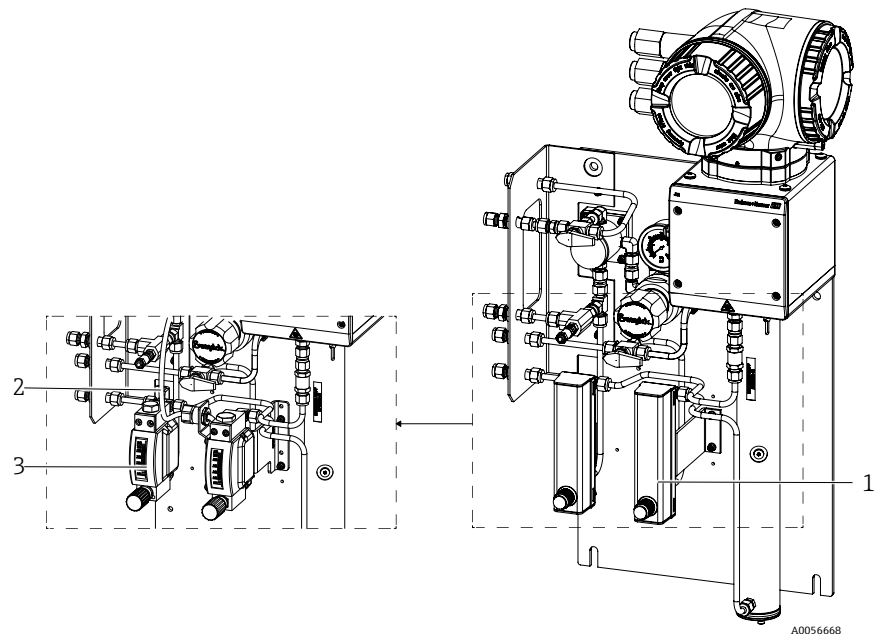

Figure 5. J22 TDLAS gas analyzer on panel, with flow meter options (2)

- | |
|---|
| 1 Flow meters (bypass and analyzer, optional) |
| 2 Flow sensor wire (optional) |
| 3 Armored flow meters (optional) |

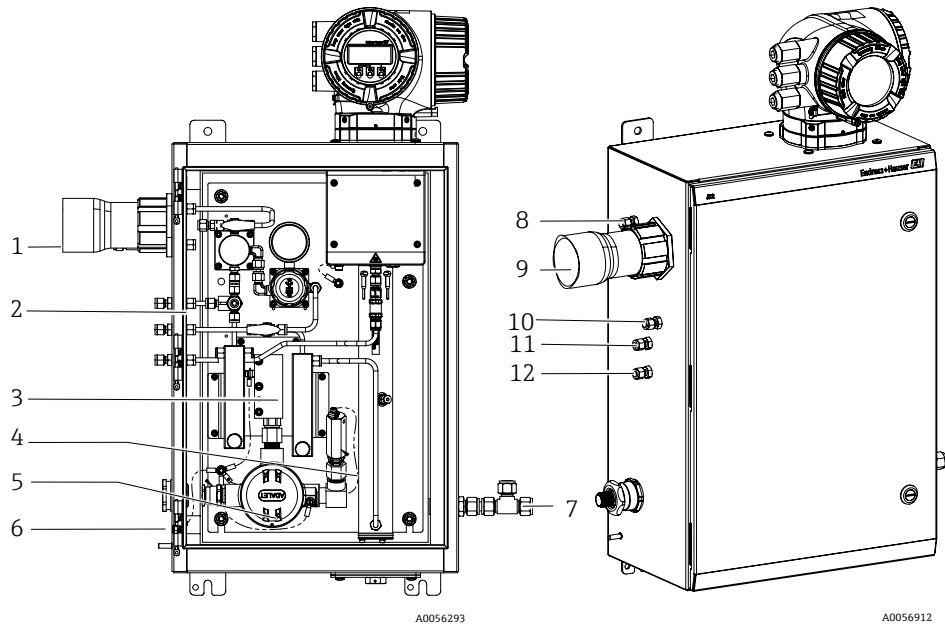

Figure 6. J22 TDLAS gas analyzer with enclosed SCS - sample system and gas connections

- | | |
|--|---|
| 1 Heat trace boot (optional) | 8 Enclosure purge in (optional) |
| 2 Insulation, 5 walls plus door (optional) | 9 Sample in, 140-310 kPa (20-45 psi) |
| 3 Heater block and plate (optional) | 10 Relief vent, Factory set, 350 kPa (50 psig), to safe area (optional) |
| 4 Thermostat (optional) | 11 Reference gas in, 15-70 kPa (2-10 psi) |
| 5 Heater power in terminal (optional) | 12 Sample vent, to safe area |
| 6 Cable entry (CSA shown) (optional) | |
| 7 Enclosure purge out, to safe area | |

Safety

The J22 offers a range of specific functions to support protective measures for the operator. These functions can be configured by the user and will guarantee greater operational safety if used correctly. An overview of the most important functions is provided below.

Function/Interface	Factory Setting	Recommendation
Write protection via hardware write protection switch	Not enabled	On an individual basis following risk assessment.
Access code (also applies to Web Server login)	Not enabled (0000)	Assign a customized access code during commissioning.
Web server	Enabled	On an individual basis following risk assessment.

Protecting access via hardware write protection

Write access to the device parameters via the local display. A web browser can be disabled via a write protection switch (DIP switch on the motherboard). When hardware write protection is enabled, only read access to the parameters is possible.

Hardware write protection is disabled by default from the factory.

Protecting access via a password

Different passwords are available to protect write access to the device parameters. The user-specific access code protects write access to the device parameters via the local display, such as a web browser. Access authorization is clearly regulated through the use of a user-specific access code.

User-specific access code

Write access to the device parameters via the local display. Web browser can be protected by the modifiable, user-specific access code.

Access via Web server

The Web server is enabled when the analyzer system is delivered. The Web server can be disabled if necessary (e.g., after commissioning) via the Web server functionality parameter.

The analyzer system and status information can be hidden on the login page. This prevents unauthorized access to the information.

Access via service interface (CDI-RJ45)

The device can be accessed via the service interface (CDI-RJ45). Device-specific functions guarantee the secure operation of the J22 in a network.

The use of relevant industrial standards and guidelines that have been defined by national and international safety committees, such as IEC/ISA62443 or the IEEE, is recommended. This includes organizational security measures such as the assignment of access authorization as well as technical measures such as network segmentation.



Connection to the service interface (CDI-RJ45) shall only be permitted by trained personnel on a temporary basis for the purpose of test, repair or overhaul of the equipment, and only if the area where the equipment is to be installed is known to be non-hazardous.

Communications

Output Type	Modbus RS485 or Modbus TCP over Ethernet (I/O1)	U _N = 30 VDC U _M = 250 VAC N = nominal, M = maximum
	Relay Output (I/O2 and/or I/O3)	U _N = 30 VDC U _M = 250 VAC I _N = 100 mA DC / 500 mA AC
	Configurable I/O ¹ (I/O2 and/or I/O3)	U _N = 30 VDC U _M = 250 VAC

¹ The configurable I/O can be configured by the HMI and Web server interface, set as a 4-20 mA output to indicate concentration, cell temperature, pressure or dewpoint temperature

Installation

Environment

If operating outdoors:

- Install the measuring device in a shady location.
- Avoid direct sunlight.

Readability of the local display

-20 °C to 60 °C (-4 °F to 140 °F)



The readability of the display may be impaired at temperatures outside the temperature range.

Storage

- ▶ Select a storage location where moisture cannot collect in the J22 controller or enclosure.
- ▶ If protection caps or protective covers are mounted, do not remove before installing the J22.

Mounting

Mounting the J22 is based on the style of analyzer. When ordered without a sample conditioning system, the J22 analyzer may be specified with an optional mounting plate for installation. When specified with a sample conditioning system the analyzer may be wall or post-mounted. Refer to the Safety and Operating Instructions for installation-related safety information.



Mounting hardware used for the J22 TDLAS gas analyzer must be able to support four times the weight of the instrument (approximately 16 kg (36 lbs) - 43 kg (95 lbs) depending on configuration).

Plate mounted

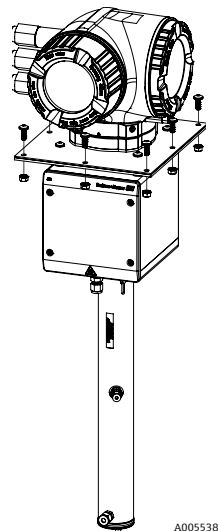

Figure 7. Optional mounting plate allows top-mounting of the J22 analyzer within user-supplied enclosure (not shown)

Wall mounted

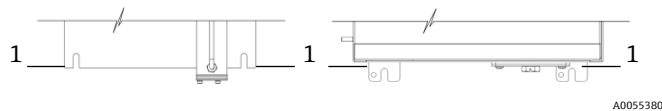

Figure 8. Slotted tabs (1) at base of panel or enclosure, mounting holes (not shown) at top of panel or enclosure

Post mounted

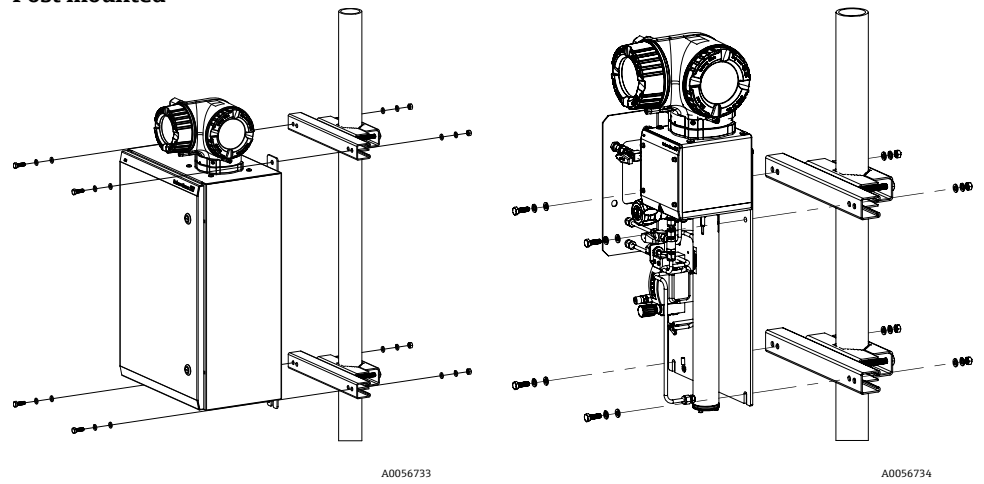

Figure 9. Post mounting of J22 TDLAS gas analyzer with enclosure (left) and on a panel (right)

Dimensions

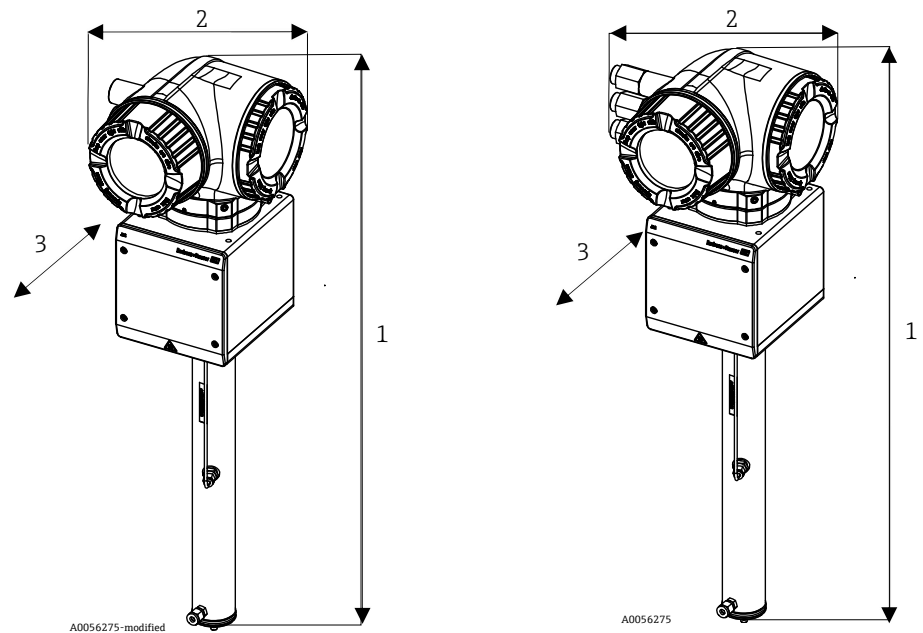

Figure 10. J22 TDLAS gas analyzer, ATEX configuration (left) and CSA configuration (right)

#	Description
1	CSA and ATEX: 727 mm (28.6 in.) high
2	CSA: 224 mm (8.8 in.) wide ATEX: 192 mm (7.5 in.) wide
3	CSA and ATEX: 236.2 mm (9.3 in.) deep

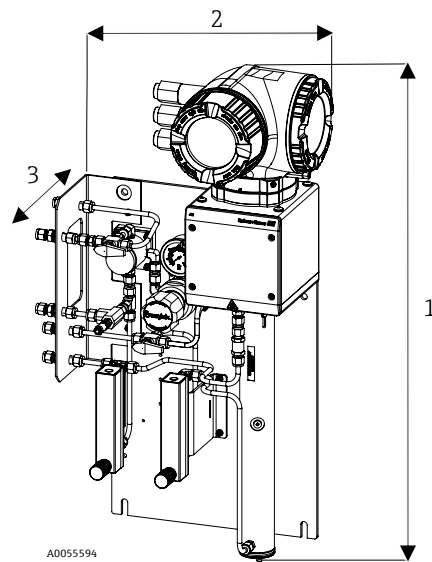

Figure 11. J22 TDLAS gas analyzer with SCS on panel

- 1 727 mm (28.6 in.) High
- 2 376 mm (14.8 in.) Wide
- 3 241 mm (9.5 in.) Deep

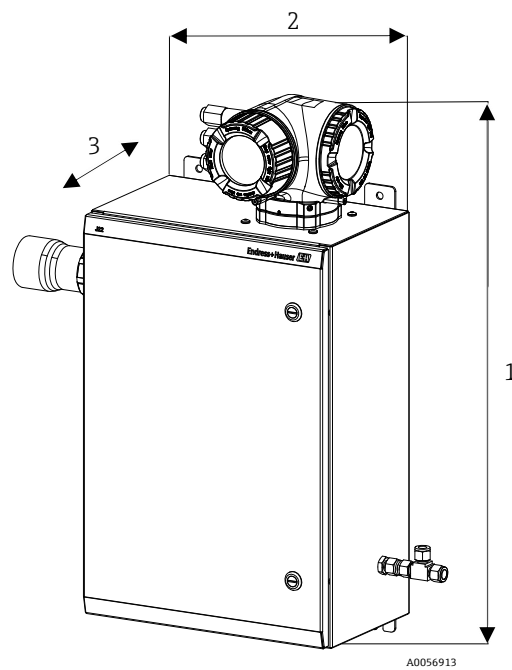

Figure 12. J22 TDLAS gas analyzer with enclosed SCS

- 1 838 mm (33 in.) High
- 2 406 mm (16 in.) Wide
- 3 255 mm (10 in.) Deep

Threaded cable entries

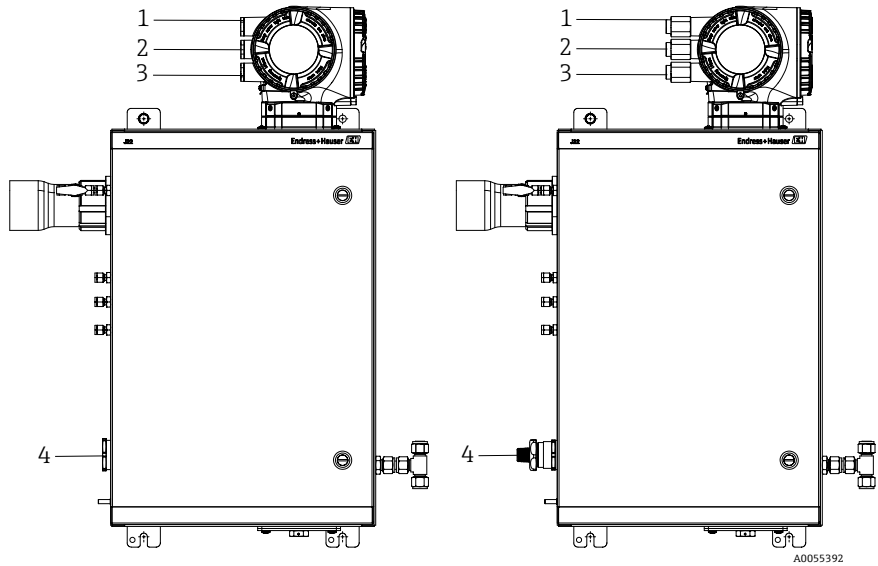

Figure 13. J22 threaded entries for enclosure for ATEX (left) and imperial (right) connections

Cable Entry	Description	ATEX, IECEx, INMETRO	Optional imperial connections
1	Controller power	M20 x 1.5	1/2 in. NPTF
2	Modbus output	M20 x 1.5	1/2 in. NPTF
3	(2) Configurable I/O	M20 x 1.5	1/2 in. NPTF
4	Heater power	M25 x 1.5	1/2 in. NPTM

Electrical connections

Controller connections

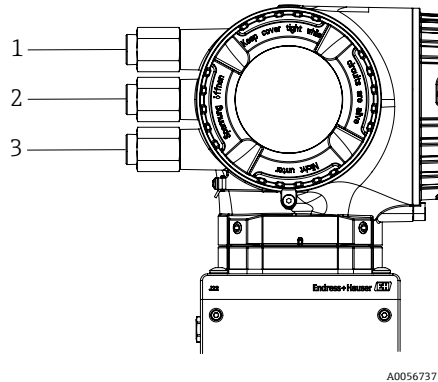
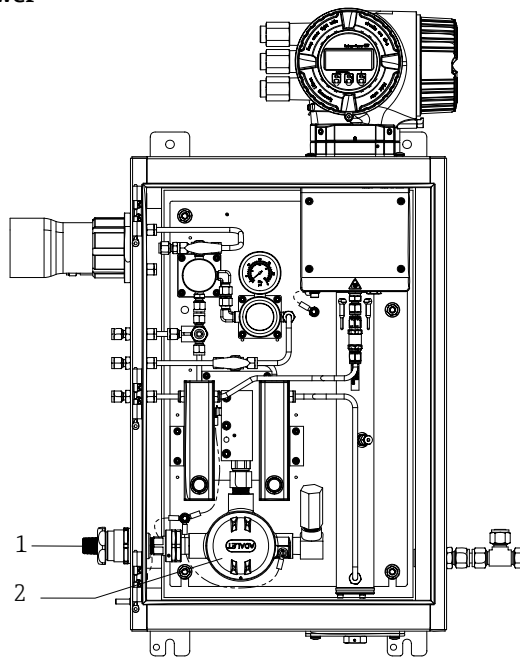

Figure 14. J22 TDLAS gas analyzer controller connections

#	Description
1	Cable entry for supply voltage
2	Cable entry for signal transmission; IO1, or Modbus RS485, or Ethernet network connection (RJ45)
3	Cable entry for signal transmission; IO2, IO3

Enclosure heater power



A0056293

Figure 15. J22 enclosure heater power connections

#	Description
1	Threaded entry for heater power
2	Heater power junction box (JB)

Tubing connections

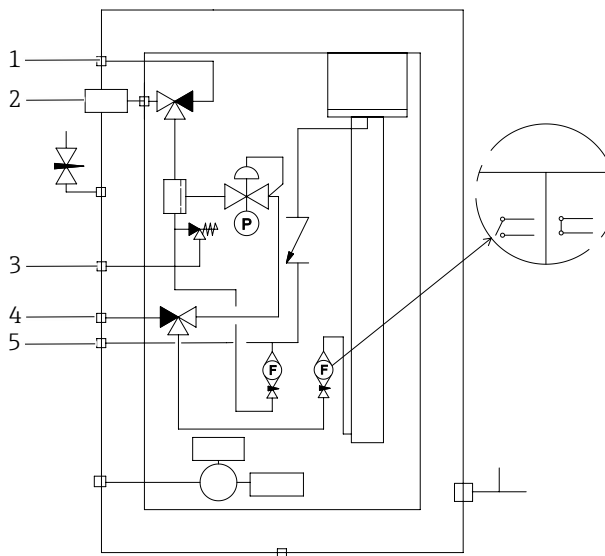

A0056767

Figure 16. J22 TDLAS gas analyzer flow diagram for fully loaded sample systems

#	Description
1	Sample purge
2	Sample supply
3	Relief vent
4	Validation inlet
5	System vent

Communications

User interface

Operator-oriented menu structure for user-specific tasks

- Commissioning
- Operation
- Diagnostics
- Expert level
- Validation

Fast and safe commissioning

- Guided menus for applications
- Menu guidance with brief descriptions of the individual parameter functions
- Access to the device via the web server

Reliable operation

- Uniform operating philosophy applied to device and operating tools
- If replacing electronic modules, transfer the device configuration via the integrated memory
- HistoROM backup which contains the process and measuring device data and the event logbook
- No need to reconfigure

Efficient diagnostics increase measurement availability

- Troubleshooting measures can be called up via the device and in the operating tools
- Diverse simulation options, logbook for events that occur and optional line recorder functions
- Auto-validation allows measurement verification against user-supplied gas standards.

Heartbeat Technology

Package	Description
Heartbeat Verification + Monitoring	<p>Heartbeat Verification</p> <ul style="list-style-type: none"> ■ Meets the requirement for traceable verification to DIN ISO 9001:2008 Chapter 7.6 a) "Control of monitoring and measuring equipment". ■ Functional testing in the installed state without interrupting the process. ■ Traceable verification results on request, including a report. ■ Simple testing process via local operation or other operating interfaces. ■ Clear measuring point assessment (pass/fail) with high test coverage within the framework of manufacturer specifications. ■ Extension of calibration intervals according to operator's risk assessment. <p>Continuously supplies data, which are characteristic of the measuring principle, to an external condition monitoring system for preventive maintenance or process analysis. These data enable the operator to:</p> <ul style="list-style-type: none"> ■ draw conclusions - using these data and other information - about the impact ■ process influences (such as corrosion, abrasion, buildup) have on the measuring performance over time ■ schedule servicing in time ■ monitor the process or product quality, e.g., gas pockets

Local operation

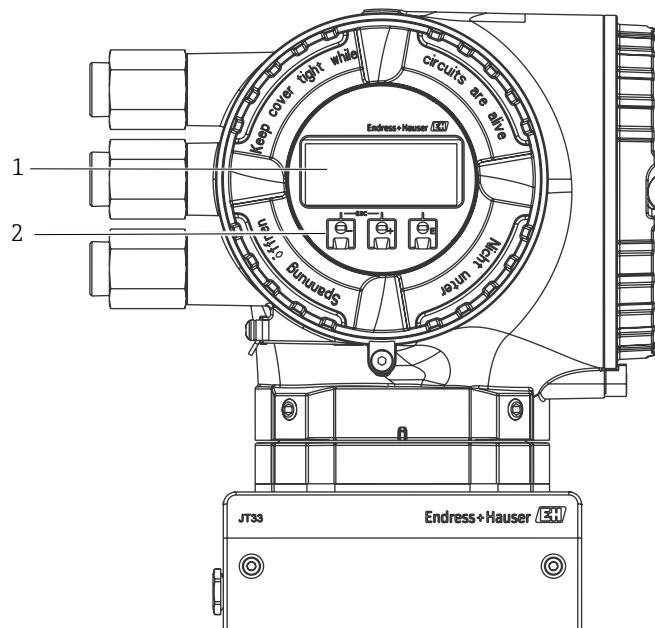

A0054799

Figure 17. J22 keypad and display for local operation

#	Description
1	4-line backlit display
2	Through-glass optical keypad

Display features

- 4-line, illuminated, graphic display
- White background lighting; switches to red in event of device errors
- Format for displaying measured variables and status variables can be individually configured
- Permitted ambient temperature for the display: -20 to 60 °C (-4 to 140 °F)
- The readability of the display may be impaired at temperatures outside the temperature range.

Operating features

- External operation via touch control (3 optical keys) without opening the housing: \oplus , \square , \boxplus
- Operating elements also accessible in hazardous areas

Remote operation

This communication interface is available in device versions with a Modbus RS485 output.

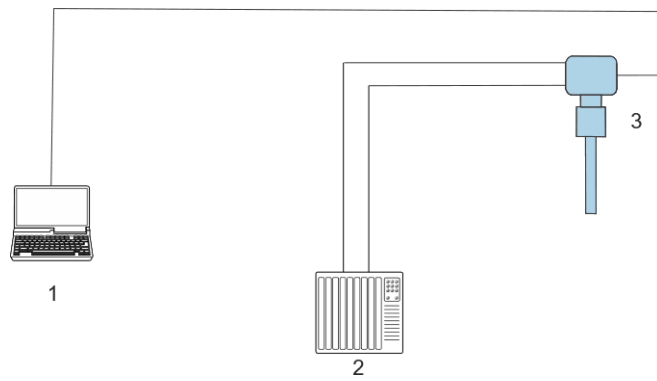

Figure 18. Options for remote connection through Modbus RS485 output

#	Name
1	Computer with web browser, such as Internet Explorer, for temporarily accessing the device web server for settings and diagnostics
2	Automation/control system, such as PLC
3	J22 TDLAS gas analyzer

Via Modbus TCP protocol

This communication interface is available via Modbus TCP/IP network: star topology.

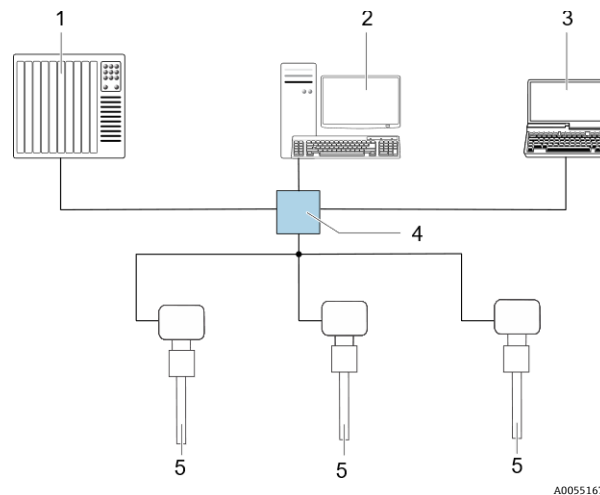

Figure 19. Options for remote operation via Modbus TCP protocol (star topology)

#	Description
1	Automation/control system, such as PLC
2	Workstation for measurement operation
3	Computer with web browser for accessing the integrated device web server
4	Ethernet switch
5	J22 TDLAS gas analyzer

Service interface

Service interface (CDI-RJ45)

A temporary point-to-point connection can be established to configure the device onsite. With the housing open, the connection is established directly via the service interface (CDI-RJ45) of the device.

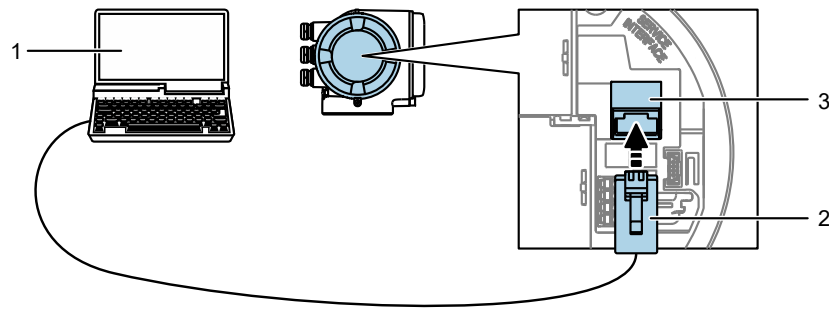

A0027563

Figure 20. Connection via service interface (CDI-RJ45)

#	Description
1	Computer with web browser, such as Internet Explorer or Microsoft Edge, for accessing the integrated device web server
2	Standard ethernet connecting cable with RJ45 connector
3	Service interface (CDI-RJ45) of the measuring device with access to the integrated web server

Supported operating tools

Different operating tools can be used for local or remote access to the measuring device. Depending on the operating tool used, access is possible with different operating units and via a variety of interfaces.

Supported Operating Tools	Operating Unit	Interface	Additional Information
Web browser	Notebook, pc or tablet with Web browser	CDI-RJ45 service interface	Special documentation for J22

Web server

Thanks to the integrated web server, the device can be operated and configured via a web browser and via a service interface (CDI-RJ45) or via a WLAN interface. The structure of the operating menu is the same as for the local display. In addition to the measured values, status information on the device is also displayed and allows the user to monitor the status of the device. The device data can also be managed and the network parameters can be configured.

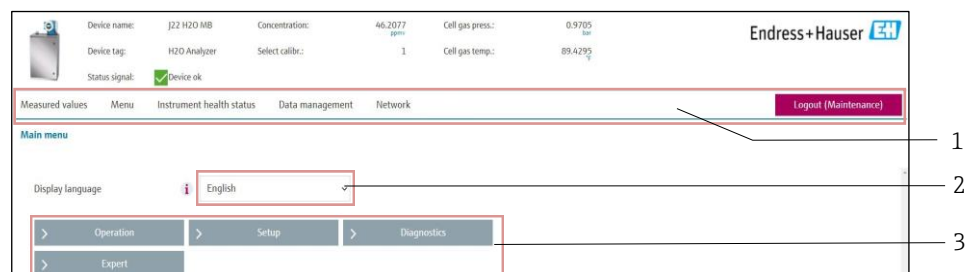

A0029418-SSI

Figure 21. Web server user interface

#	Description
1	Function row
2	Local display language
3	Navigation area

Supported functions

Data exchange between the operating unit (such as a notebook, for example) and the measuring device:

- Upload the configuration from the measuring device (XML format, configuration backup)
- Save the configuration to the measuring device (XML format, restore configuration)
- Export event list (.csv file)
- Export parameter settings (.csv file or PDF file, document the measuring point configuration)
- Export the Heartbeat verification log
- Flash firmware version for device firmware upgrade, for example
- Download driver for system integration
- Visualize the saved measured values

HistoROM data management

The measuring device features HistoROM data management. HistoROM data management comprises both the storage and import/export of key device and process data, making operation and servicing far more reliable, secure and efficient.



When the device is delivered, the factory settings of the configuration data are stored as a backup in the device memory. This memory can be overwritten with an updated data record, for example after commissioning.

Additional information on the data storage concept

There are different types of data storage units in which device data are stored and used by the device.

	Device Memory	T-DAT	S-DAT
Available data	<ul style="list-style-type: none"> ■ Event logbook such as diagnostic events for example ■ Parameter data record backup ■ Device firmware package 	<ul style="list-style-type: none"> ■ Measured value logging ■ Current parameter data record (used by firmware at run time) ■ Maximum indicators (min/ max values) 	<ul style="list-style-type: none"> ■ Sensor data ■ Serial number ■ Calibration data ■ Device configuration (e.g., SW options, fixed I/O or multi I/O)
Storage location	Fixed on the user interface board in the connection compartment	Attachable to the user interface board in the connection compartment	Fixed in the optical head enclosure

Data backup

Automatic

- The most important device data (sensor and transmitter) are automatically saved in the DAT modules.
- If the transmitter or measuring device is replaced: once the T-DAT containing the previous device data has been exchanged, the new measuring device is ready for operation without any errors.
- If the sensor is replaced: once the sensor has been replaced, new sensor data are transferred from the S-DAT in the measuring device and the measuring device is ready for operation without any errors.
- If exchanging the electronics module (e.g., I/O electronics module): Once the electronics module has been replaced, the software of the module is compared against the current device firmware.

The module software is upgraded or downgraded where necessary. The electronics module is available for use immediately afterwards without compatibility problems.

Manual

Additional parameter data record (customer set-up parameter settings) in the integrated device memory HistoROM backup for:

- Data backup function
- Backup and subsequent restoration of a device configuration in the device memory HistoROM backup
- Data comparison function: Comparison of the current device configuration with the device configuration saved in the device memory HistoROM backup

Data transfer

Manual transfer of a device configuration to another device using the export function of the specific operating tool, e.g., with Web server: to duplicate the configuration or to store in an archive (e.g., for backup purposes).

Event list

- Automatic event tracking
- Data backup function
- Extended HistoROM application package gives chronological display of up to 100 event messages in the events list along with a time stamp, plain text description and remedial measures
- The events list can be exported and displayed via a variety of interfaces and operating tools e.g., Web server



Data logging



Extended HistoROM application package gives manual tracking:

- Up to 1000 measured values recorded via 1 to 4 channels
- User configurable recording interval
- Up to 250 measured values recorded via each of the 4 memory channels
- Export the measured value log via a variety of interfaces and operating tools e.g., Web server

Certificates and approvals

CE mark	The J22 TDLAS gas analyzer meets the legal requirements of the applicable EU Directives. These are listed in the corresponding EU Declaration of Conformity along with the standards applied. Endress+Hauser confirms successful testing of the device by affixing the CE mark.
Ex approval	The measuring device is certified for use in hazardous areas and the relevant safety instructions are provided in the separate <i>Safety Instructions</i> . Reference is made to this document on the nameplate. The Safety Instructions containing all the relevant explosion protection data is available from the Endress+Hauser website.
CRN approval	J22 products may be specified with CRN approval (Canadian Registration Number) for both analyzer and sample system components. CRN-approved devices are marked with a registration number.

Area classifications	Model	Certifications
	J22 TDLAS gas analyzer	<p><u>cCSAus</u>: Ex db ia [ia Ga] op is IIC T4 Gb Class I, Zone 1, AEx db ia [ia Ga] op is IIC T4 Gb Class I, Division 1, Groups A, B, C, D, T4 Tambient = -20 °C to 60 °C</p> <p><u>ATEX/IECEX/UKEX</u>:  II 2G Ex db ia [ia Ga] ib op is IIC T4 Gb Tambient = -20 °C to 60 °C</p> <p><u>IECEX (PESO)</u>: Ex db ia [ia Ga] ib op is IIC T4 Gb Tambient = -20 °C to 60 °C</p> <p><u>JPN</u>: Ex db ia [ia Ga] ib op is IIC T4 Gb Tambient = -20 °C to 60 °C</p> <p><u>KTL</u>: Ex db ia [ia Ga] ib op is IIC T4 Gb Tambient = -20 °C to 60 °C</p> <p><u>INMETRO</u>: Ex db ia [ia Ga] ib op is IIC T4 Gb Tambient = -20 °C to 60 °C</p> <p><u>CNEx</u>: Ex db ia [ia Ga] ib op is IIC T4 Gb Tambient = -20 °C to 60 °C</p>
	J22 TDLAS gas analyzer with SCS ¹ on a panel	<p><u>cCSAus</u>: Ex db ia op is IIC T4 Gb Class I, Zone 1, AEx db ia op is IIC T4 Gb Class I, Division 1, Groups A, B, C, D, T4 Tambient = -20 °C to +60 °C</p> <p><u>ATEX/IECEX/UKEX</u>:  II 2G Ex db ia ib op is h IIC T4 Gb Tambient = -20 °C to 60 °C</p> <p><u>IECEX (PESO)</u>: Ex db ia [ia Ga] ib op is IIC T4 Gb (analyzer) SCS supplied with certified components Tambient = -20 °C to 60 °C</p> <p><u>JPN</u>: Ex db ia ib op is IIC T4 Gb Tambient = -20 °C to 60 °C</p> <p><u>KTL</u>: Ex db ia ib op is h IIC T4 Gb Tambient = -20 °C to 60 °C</p> <p><u>INMETRO</u>: Ex db ia ib op is h IIC T4 Gb Tambient = -20 °C to 60 °C</p> <p><u>CNEx</u>: Ex db ia ib op is h IIC T4 Gb Tambient = -20 °C to 60 °C</p>

J22 TDLAS gas analyzer with enclosed SCS ¹	<p><u>cCSAus</u>: Ex db ia op is IIC T4 Gb Class I, Zone 1, AEx db ia op is IIC T4 Gb Class I, Division 1, Groups A, B, C, D, T4 Tambient = -20 °C to 60 °C</p> <p><u>ATEX/IECEX/UKEX</u>:  II 2G Ex db ia ib op is h IIC T4 Gb Tambient = -20 °C to 60 °C</p> <p><u>IECEX (PESO)</u>: Ex db ia [ia Ga] ib op is IIC T4 Gb (analyzer) SCS supplied with certified components Tambient = -20 °C to 60 °C</p> <p><u>JPN</u>: Ex db ia ib op is IIC T4 Gb Tambient = -20 °C to 60 °C</p> <p><u>KTL</u>: Ex db ia ib op is h IIC T4 Gb Tambient = -20 °C to 60 °C</p> <p><u>INMETRO</u>: Ex db ia ib op is h IIC T4 Gb Tambient = -20 °C to 60 °C</p> <p><u>CNEEx</u>: Ex db ia ib op is h IIC T3 Gb Tambient = -20 °C to 60 °C</p>
J22 TDLAS gas analyzer with enclosed SCS ¹ , with heater	<p><u>cCSAus</u>: Ex db ia op is IIC T3 Gb Class I, Zone 1, AEx db ia op is IIC T3 Gb Class I, Division 1, Groups B, C, D, T3 Tambient = -20 °C to 60 °C</p> <p><u>ATEX/IECEX</u>:  II 2G Ex db ia ib op is h IIC T3 Gb Tambient = -20 °C to 60 °C</p> <p><u>IECEX (PESO)</u>: Ex db ia [ia Ga] ib op is IIC T4 Gb (analyzer) SCS supplied with certified components Tambient = -20 °C to 60 °C</p> <p><u>JPN</u>: Ex db ia ib op is IIC T3 Gb Tambient = -20 °C to 60 °C</p> <p><u>KTL</u>: Ex db ia ib op is h IIC T3 Gb Tambient = -20 °C to 60 °C</p> <p><u>INMETRO</u>: Ex db ia ib op is h IIC T3 Gb Tambient = -20 °C to 60 °C</p> <p><u>CNEEx</u>: Ex db ia ib op is h IIC T3 Gb Tambient = -20 °C to 60 °C</p>
Ingress Protection	Type 4X, IP66

¹ Sample Conditioning System

Ordering Information

Order codes

Available order codes for the J22 TDLAS gas analyzer are listed below. Refer to the website (<https://www.endress.com/contact>) to locate your local sales channel for more information.

Feature number	Order code	Description
Approval (Choose one)		
10	BA	ATEX/IECEX/UKEx: Z1, db ia [ia Ga] ib op is IIC T3/T4 Gb
	CB	cCSAus: CL.I DIV1 AEx/Ex db ia [ia Ga] op is IIC T3/T4 Gb ¹
	ID	PESO: Zone 1 Ex db ia [ia Ga] ib op is IIC T4 Gb (analyzer only, SCS supplied with certified components)
	JD	JPN: Zone 1, Ex db [Ga] IIC T3/T4 Gb
	KD	KTL: Zone 1 Ex db [Ga] IIC T3/T4 Gb
	MD	INMETRO: Zone 1, Ex db [Ga] IIC T3/T4 Gb
	HD	CNEx (China) : Zone1 Ex db [Ga] IIC T3/T4 Gb
Approval (Choose one)		
20	H ₂ O	H ₂ O
Measurement Range (Choose one)		
30	AA	0 to 500 ppmv H ₂ O
	AC	0 to 2000 ppmv H ₂ O
	AD	0 to 6000 ppmv H ₂ O
Stream Composition (Choose one)		
50	T2	Natural gas (Table 1 and Table 2)
	T3	T3
Venting Options (Choose one)		
60	A	Atmosphere
	F	Flare ³
Measurement Wetted Materials (Choose one)		
70	V	316 Stainless steel; FKM seals ⁴
Power (Choose one)		
80	A	100 to 240 VAC ⁵
	D	24 VDC 5
Output 1 (Choose one)		
90	1	Modbus RTU over RS485 (2-wire)
	2	Modbus TCP over Ethernet (RJ45)
Output 2 (Choose one)		
100	N	None

	1	Configurable I/O ⁶
	2	Relay output
Output 3 (Choose one)		
110	N	None
	1	Configurable I/O ⁶
	2	Relay output
Controller Housing (Choose one)		
120	1	Coated copper-free aluminum
	2	Cast stainless steel
Controller Mounting (Choose one)		
130	1	Fixed controller mount with HMI
	2	Fixed controller mount with HMI (plate mounting for user supplied enclosure) ⁷
Sample Conditioning System (Choose one)		
140	A	On Panel, anodized aluminum
	B	Enclosed, 304 Stainless Steel
	C	Enclosed, 316 Stainless Steel
	N	None ⁷
Filtration (Choose one)		
150	1	Membrane separator (no 7 micron filter) with bypass
	2	7 micron filter, no bypass ⁸
	N	None
Sample System Gas Connections (Choose one)		
160	A	Imperial
	B	Metric ⁹
Pressure Regulation (Choose one)		
170	A	Pressure regulator (factory default)
	B	Pressure regulator plus pressure relief valve (factory default)
	C	Pressure regulator, Parker ¹⁰
	D	Pressure regulator, Parker, plus pressure relief valve
	N	None
Flow Meter (Choose one)		
180	F	Glass tube, factory default
	G	Armored flow meter, factory default

	K	Glass tube, Krohne ¹⁰
	N	None
	P	Armored Krohne flow meter with Krohne flow switches
Heating Options (Choose one)		
190	1	Heated + Heat-Trace Boot, 100 to 240 VAC ¹¹
	8	None
Safety Purge (Choose one)		
200	A	For enclosed SCS (H ₂ S >300 ppm) ¹²
	B	For panel mount SCS (H ₂ S>300 ppm) ¹²
	N	None
Optional – Test, Certificate, Declaration		
580 ⁶	JA	Inspection certificate 3.1, EN10204 (MTR) (includes sample system)
	JB	NACE MR0175 / ISO 15156 plus inspection certificate 3.1, EN10204 (MTR) (includes sample system)
	JH	Inspection certificate 3.1, EN10204 (MTR) (analyzer only)
580 ⁶	JI	NACE MR0175 / ISO 15156 plus inspection certificate 3.1, EN10204 (MTR) (analyzer only)
	K9	Special version, TSP - no. to be spec.
Optional – Additional Approvals		
590	LS	CRN Approval for analyzer and sample conditioning system ¹³

Notes

1. CSA controller is shipped with plugged NPT adapters for power and I/O access.
2. Stream composition must be provided upon order placement. Order will be delayed if stream composition is not provided.
3. Vent to flare option includes a backpressure check valve to prevent gas flow back into the analyzer.
4. FKM, also known as FPM, seals are a fluorinated, carbon-based synthetic rubber.
5. 24 VDC option is valid for controller power only. Sample conditioning system power are AC only. Refer to the Technical Data for detailed electrical specifications.
6. Configurable I/O can be configured by customer for 4-20mA input, output or digital status/switch output.
7. When choosing “none” for a sample conditioning system, all other options for sample conditioning should be “none” with the exception that a sample system gas connection type should be chosen. Analyzers purchased for mounting in third-party sample system enclosure should select controller mounting with plate mount bracket for top-down installation.
8. When choosing the filter with no bypass option, the pressure regulator with a pressure relief valve is not a valid combination.
9. When choosing the metric sample system gas connection option, Imperial to metric conversion parts will ship in a separate package inside the analyzer crate.
10. When choosing the premium option with Parker pressure regulation, the premium flow meter option for Krohne must be chosen.
11. Heating is not available for panel mount sample conditioning systems. Refer to the Technical Data for detailed electrical specifications.
12. A purge kit is required for applications where H₂S concentration is higher than 300 ppm.
 - a. The safety purge option for the enclosure include two (2) purges; one for the enclosure and one for the sample gas flow tubing.
 - b. There is only one safety purge for the sample gas flow tubing on a panel mount configuration.

13. When choosing CRN approval for analyzer with sample conditioning system the following components must be selected:
- Feature 170: Order Codes C, D, N
 - Feature 180: Order Code G, P, N

Gas specifications

Component name	Chemical symbol	Allowable component range 1		
		Natural Gas	Rich Natural Gas	Rich Natural Gas/ Pure CO ₂
		Table 1	Table 2	Table 3
Methane	C ₁	90 to 100%	50 to 100%	0 to 50%
Ethane	C ₂	0 to 7%	0 to 20%	0 to 20%
Propane	C ₃	0 to 2%	0 to 15%	0 to 15%
Butanes	C ₄	0 to 1%	0 to 5%	0 to 5%
Pentanes	C ₅	0 to 0.2%	0 to 2%	0 to 2%
Hexanes and Heavier	C ₆₊	0 to 0.2%	0 to 2%	0 to 2%
Carbon Dioxide	CO ₂	0 to 3%	0 to 20%	50 to 100%
Nitrogen and other Inerts	N ₂	0 to 10%	0 to 20%	0 to 20%
Hydrogen Sulfide	H ₂ S	0 to 300 ppmv	0 to 5%	0 to 5%
Water	H ₂ O	0 to 5000 ppmv	0 to 5000 ppmv	0 to 5000 ppmv

1. For this table, stream composition must be supplied at the time of order placement.

Technical data	
Measurement data	
Target component	H ₂ O in Natural Gas
Principle of measurement	Tunable Diode Laser Absorption Spectroscopy (TDLAS)
Measurement ranges	0 to 500 ppmv (0 to 24 lb/mmscf) 0 to 2000 ppmv (0 to 95 lb/mmscf) 0 to 6000 ppmv (0 to 284 lb/mmscf)
Repeatability	± 1 ppmv or ±1% of reading (whichever is greater)
Accuracy	± 2 ppmv, plus 2% of reading (refer to calibration certificate included with analyzer for specific accuracy values)
Application data	
Ambient temperature range	-20 °C to +60 °C (-4 °F to +140 °F), during operation
Environmental Temperature Range/ Sample Cell Temperature Range	Storage (analyzer and analyzer on panel): -40 °C to +60 °C (-40 °F to +140 °F) Storage (analyzer with enclosed SCS ²): -30 °C to +60 °C (-22 °F to +140 °F) Operation: -20 °C to +60 °C (-4 °F to +140 °F)
Environment: Pollution Degree	J22 is rated Type 4X and IP66 for outdoor use and is considered pollution degree 2 internally
Altitude	Up to 2,000 m
Sample Inlet Pressure	140-310 kPaG (20-45 psi)
Measurement Ranges	500 ppmv = 24 lb/mmscf 2000 ppmv = 95 lb/mmscf 6000 ppmv = 284 lb/mmscf
Sample Cell Operating Pressure Range	800-1200 mbar (standard) 800-1700 mbar (optional)
Sample Flow Rate	0.5-1.0 slpm (1-2 scfh)
Bypass Flow Rate	0.5-1.0 slpm (1-2 scfh)
Electrical and communication	
Controller display	4-line back-lit display with touch control
Controller operation	Configuration via display or web servers
Controller housing materials	Copper-free aluminum with 60-150 µm polyester resin coating Cast stainless steel, 1.4409 (CF3M) similar to 316L

Outputs and Communications	I/O1: Modbus RTU over RS485 or Modbus TCP over Ethernet I/O2 and 3: Software configurable; set as relay output, analog output (4-20 mA) or digital/status output	
Power supply	Controller: 24 VDC \pm 20% or 100 to 240 VAC \pm 10%, 50/60 Hz, 10W $U_M=250$ VAC Optional heater: 100 to 240 VAC \pm 10%, 50/60 Hz, 80W	
Output Type	Modbus RS485 or Modbus TCP over Ethernet (IO1)	$U_N = 30$ VDC $U_M = 250$ VAC N = nominal, M = maximum
	Relay Output (IO2 and/or IO3)	$U_N = 30$ VDC $U_M=250$ VAC $I_N=100$ mA DC/500 mA AC
	Configurable IO (IO2 or IO3)	$U_N=30$ VDC $U_M=250$ VAC
	Intrinsically Safe Output (Flow Switch)	$U_o = \pm 5.88$ V $I_o = 4.53$ mA $P_o = 6.6$ mW $C_o = 43$ μ F $L_o = 1.74$ H
Ingress protection (analyzer and sample system)	IP66, Type 4X	
Sample conditioning system		
Panel and enclosure materials	Sample panel: anodized aluminum Sample conditioning enclosure: 304 stainless steel	
Inlet pressure range	140 to 310 kPa (20 to 45 psi)	
Sample cell operating pressure range	Application dependent 800 to 1200 mbara (atmosphere) - Standard 800 to 1700 mbara (flare) - Optional	
Sample cell tested pressure range	-25 to 689 kPa (-7.25 to 100 psig)	
Maximum cell pressure	345 kPa (50 psig)	
Analyzer flow rate	Not including bypass: 0.5 to 1.0 slpm (1 to 2 scfh) Bypass flow: 0.5 slpm (1 scfh) in addition to analyzer flow	
Wetted materials including sample measurement cell	316L stainless steel, Fluoroelastomer (FKM) O-rings, glass	
Sample conditioning components	Includes verification port and options for filtration, pressure regulation, flow meters, flow switches and safety purge	

Certifications and marks



www.addresses.endress.com
