

Operating Instructions

Cerabar S PMC71, PMP71, PMP75

Process pressure measurement
PROFIBUS PA



Make sure the document is stored in a safe place such that it is always available when working on or with the device.

To avoid danger to individuals or the facility, read the "Basic safety instructions" section carefully, as well as all other safety instructions in the document that are specific to working procedures.

The manufacturer reserves the right to modify technical data without prior notice. Your Endress+Hauser distributor will supply you with current information and updates to this manual.

Table of contents

1	About this document	4	7.9	System units (SET UNIT TO BUS)	68
1.1	Document function	4	8	Maintenance	69
1.2	Symbols	4	8.1	Cleaning instructions	69
1.3	Registered trademarks	5	8.2	Exterior cleaning	69
2	Basic safety instructions	6	9	Troubleshooting	70
2.1	Requirements for the personnel	6	9.1	Messages	70
2.2	Intended use	6	9.2	Response of outputs to errors	78
2.3	Workplace safety	6	9.3	Confirming messages	80
2.4	Operational safety	6	9.4	Repair	81
2.5	Hazardous area	7	9.5	Repair of Ex-certified devices	81
2.6	Product safety	7	9.6	Spare parts	81
3	Identification	8	9.7	Returns	81
3.1	Product identification	8	9.8	Disposal	81
3.2	Device designation	8	9.9	Software history	82
3.3	Scope of delivery	8	9.10	Hardware history	82
3.4	Certificates and approvals	9	10	Technical data	83
4	Mounting	10		Index	84
4.1	Incoming acceptance, transport, storage	10			
4.2	Installation requirements	10			
4.3	General installation instructions	11			
4.4	Installation instructions	11			
4.5	Post-installation check	20			
5	Wiring	21			
5.1	Connecting the device	21			
5.2	Connecting the measuring unit	22			
5.3	Overvoltage protection (optional)	23			
5.4	Post-connection check	23			
6	Operation	24			
6.1	On-site display (optional)	24			
6.2	Operating elements	25			
6.3	PROFIBUS PA communication protocol	28			
6.4	On-site operation – on-site display connected	48			
6.5	Endress+Hauser operating program	51			
6.6	HistoROM®/M-DAT (optional)	51			
6.7	Locking/unlocking operation	53			
6.8	Factory setting (reset)	54			
7	Commissioning	57			
7.1	Configuring messages	57			
7.2	Installation and function check	57			
7.3	Commissioning via Class 2 master (FieldCare) ..	58			
7.4	Selecting the language and measuring mode ..	58			
7.5	Position adjustment	60			
7.6	Pressure measurement	61			
7.7	Level measurement	63			
7.8	Scaling OUT value	67			





1 About this document

1.1 Document function







These Operating Instructions contain all the information that is required in the various phases of the life cycle of the device: from product identification, incoming acceptance and storage, to mounting, connection, operation and commissioning through to troubleshooting, maintenance and disposal.

1.2 Symbols



1.2.1 Safety symbols

Symbol	Meaning
 A0011189-EN	DANGER! This symbol alerts you to a dangerous situation. Failure to avoid this situation will result in serious or fatal injury.
 A0011190-EN	WARNING! This symbol alerts you to a dangerous situation. Failure to avoid this situation can result in serious or fatal injury.
 A0011191-EN	CAUTION! This symbol alerts you to a dangerous situation. Failure to avoid this situation can result in minor or medium injury.
 A0011192-EN	NOTE! This symbol contains information on procedures and other circumstances that do not result in personal injury.









1.2.2 Electrical symbols

Symbol	Meaning	Symbol	Meaning
	Direct current		Alternating current
	Direct current and alternating current		Ground connection A grounded terminal which, as far as the operator is concerned, is grounded via a grounding system.
	Protective ground connection A terminal that must be connected to the ground prior to establishing any other connections.		Equipotential connection A connection that has to be connected to the plant grounding system: This may be a potential equalization line or a star grounding system depending on national or company codes of practice.

1.2.3 Tool symbols

Symbol	Meaning
 A0011221	Allen key
 A0011222	Open-ended wrench

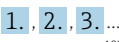
1.2.4 Symbols for certain types of Information

Symbol	Meaning
 A0011182	Permitted Indicates procedures, processes or actions that are allowed.
 A0011184	Not permitted Indicates procedures, processes or actions that are forbidden.
 A0011193	Tip Indicates additional information.
 A0028658	Reference to documentation
 A0028659	Reference to page.
 A0028660	Reference to graphic
 A0031595	Series of steps
 A0018343	Result of a series of actions
 A0028673	Visual inspection

1.2.5 Symbols in graphics

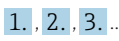
Symbol	Meaning
1, 2, 3, 4 etc.	Numbering of main items
 A0031595	Series of steps
A, B, C, D etc.	Views

1.2.6 Symbols on the device

Symbol	Meaning
 A0019159	Safety notice Observe the safety instructions contained in the associated operating instructions.

1.3 Registered trademarks

KALREZ®

Registered label of E.I. Du Pont de Nemours & Co., Wilmington, USA

TRI-CLAMP®

Registered label of Ladish & Co., Inc., Kenosha, USA

PROFIBUS PA®

Registered trademark of the PROFIBUS Trade Organization, Karlsruhe, Germany

GORE-TEX®

Trademark of W.L. Gore & Associates, Inc., USA

2 Basic safety instructions

2.1 Requirements for the personnel

The personnel responsible for installation, commissioning, diagnostics and maintenance must fulfil the following requirements:

- Trained, qualified specialists must have a relevant qualification for this specific function and task
- They must be authorized by the plant operator
- They must be familiar with national regulations
- Before beginning work, the specialist staff must have read and understood the instructions in the Operating Instructions and supplementary documentation as well as in the certificates (depending on the application)
- They must follow instructions and comply with basic conditions

The operating personnel must fulfil the following requirements:

- Are instructed and authorized according to the requirements of the task by the facility's owner-operator
- They must follow the instructions in these Operating Instructions

2.2 Intended use

The Cerabar S is a pressure transmitter for measuring level or pressure.

2.2.1 Incorrect use

The manufacturer is not liable for damage caused by improper or unintended use.

Clarification for borderline cases:

In the case of special fluids and fluids used for cleaning, Endress+Hauser is glad to provide assistance in clarifying the corrosion resistance of wetted materials, but does not accept any warranty or liability.

2.3 Workplace safety

When working on and with the device:

- Wear the required personal protective equipment as per national regulations.
- Switch off the supply voltage before connecting the device.

2.4 Operational safety

Risk of injury!

- ▶ Operate the device only if it is in proper technical condition, free from errors and faults.
- ▶ The operator is responsible for ensuring that the device is in good working order.

Modifications to the device

Unauthorized modifications to the device are not permitted and can lead to unforeseeable dangers:

- ▶ If, despite this, modifications are required, consult with Endress+Hauser.

Repair

To ensure continued operational safety and reliability:

- ▶ Carry out repairs on the device only if they are expressly permitted.
- ▶ Observe federal/national regulations pertaining to the repair of an electrical device.
- ▶ Use original spare parts and accessories from Endress+Hauser only.

2.5 Hazardous area

To eliminate danger to persons or the installation when the device is used in the hazardous area (e.g. explosion protection, pressure vessel safety):

- Check the nameplate to determine whether the ordered device can be used for the intended application in the hazardous area.
- Comply with the instructions in the separate supplementary documentation, which is an integral part of this manual.

2.6 Product safety

This measuring instrument is designed in accordance with good engineering practice to meet state-of-the-art safety requirements, has been tested, and left the factory in a condition in which it is safe to operate. It meets general safety standards and legal requirements. It also conforms to the EC directives listed in the device-specific EC Declaration of Conformity. Endress+Hauser confirms this by affixing the CE mark to the device.

3 Identification

3.1 Product identification

The measuring instrument can be identified in the following ways:

- Nameplate specifications
- Order code with breakdown of the device features on the delivery note
- Enter the serial number from the nameplates in W@M Device Viewer (www.endress.com/deviceviewer): All the information about the measuring instrument is displayed.

For an overview of the technical documentation provided, enter the serial number from the nameplates in W@M Device Viewer (www.endress.com/deviceviewer).

3.1.1 Manufacturer address

Endress+Hauser SE+Co. KG
Hauptstraße 1
79689 Maulburg, Germany
Address of the manufacturing plant: See nameplate.

3.2 Device designation

3.2.1 Nameplate

Different nameplates are used depending on the device version.

The nameplates contain the following information:

- Manufacturer name and device name
- Address of the certificate holder and country of manufacture
- Order code and serial number
- Technical data
- Approval-specific information

Compare the data on the nameplate with your order.

3.2.2 Identification of sensor type

See parameter "Sensor Meas.Type" in Operating Instructions BA00296P.

3.3 Scope of delivery

The scope of delivery comprises:

- Cerabar S pressure transmitter
- For devices with the "HistoROM/M-DAT" option:
CD-ROM with Endress+Hauser operating program
- Optional accessories

Documentation supplied:

- The BA00295P and BA00296P Operating Instructions are available on the Internet.
→ See: www.de.endress.com → Download.
- Brief Operating Instructions KA01022P
- Leporello KA00244P
- Final inspection report
- Additional Safety Instructions with ATEX, IECEx and NEPSI devices
- Optional: factory calibration certificate, test certificates

3.4 Certificates and approvals

CE mark, Declaration of Conformity

The devices are designed to meet state-of-the-art safety requirements, have been tested and left the factory in a condition in which they are safe to operate. The devices comply with the applicable standards and regulations as listed in the EC Declaration of Conformity and thus comply with the statutory requirements of the EC Directives. Endress+Hauser confirms the successful testing of the device by affixing to it the CE mark.

4 Mounting

4.1 Incoming acceptance, transport, storage

4.1.1 Incoming acceptance

- Check the packaging and contents for any signs of damage.
- Check the shipment, make sure nothing is missing and that the scope of supply matches your order.

4.1.2 Transportation to measuring point

▲ WARNING

Incorrect transportation

Housing, membrane and capillary may become damaged, and there is a risk of injury!

- ▶ Transport the measuring instrument to the measuring point in its original packaging or by the process connection (with secure transport protection for the membrane).
- ▶ Follow the safety instructions and transport conditions for devices weighing more than 18 kg (39.6 lbs).
- ▶ Do not use capillaries as a carrying aid for the diaphragm seals.

4.1.3 Storage

The measuring instrument must be stored in a dry, clean area and protected against impact (EN 837-2).

Storage temperature range:

See Technical Information.

4.2 Installation requirements

4.2.1 Installation dimensions

For dimensions, please refer to "Mechanical construction" section in TI00383P.

4.3 General installation instructions

- Devices with a G 1 1/2 thread:
 - When screwing the device into the tank, the flat seal has to be positioned on the sealing surface of the process connection. To avoid additional strain on the process membrane, the thread should never be sealed with hemp or similar materials.
- Devices with NPT threads:
 - Wrap Teflon tape around the thread to seal it.
 - Tighten the device at the hexagonal bolt only. Do not turn at the housing.
 - Do not overtighten the thread when screwing in the screw. Max. torque: 20 to 30 Nm (14.75 to 22.13 lbf ft)
- For the following process connections, a tightening torque of max. 40 Nm (29.50 lbf ft) is required:
 - Thread ISO228 G1/2 (order option "1A" or "1B")
 - Thread DIN13 M20 x 1.5 (order option "1N" or "1P")

4.3.1 Mounting sensor modules with PVDF thread

▲ WARNING

Risk of damage to process connection!

Risk of injury!

- ▶ Sensor modules with PVDF thread must be installed with the mounting bracket provided!

▲ WARNING

Material fatigue from pressure and temperature!

Risk of injury due to bursting of parts! The thread can become loose if exposed to high pressure and temperature loads.

- ▶ The integrity of the thread must be checked regularly and the thread may need to be re-tightened with the maximum tightening torque of 7 Nm (5.16 lbf ft). Teflon tape is recommended for sealing the 1/2" NPT thread.

4.4 Installation instructions

- Due to the orientation of the Cerabar S, a zero point shift may occur, i.e. when the container is empty or partially full, the measured value does not display zero. You can correct this zero point shift either via the "zero" key on the electronic insert, or on the outside of the device or via the on-site display. See → 25, "Position of operating elements", → 26, "Function of operating elements" and → 60, "Position adjustment".
- For PMP75, please refer to → 14 "Installation instructions for devices with diaphragm seals – PMP75".
- It is possible to rotate the housing by up to 380° to ensure optimum readability of the on-site display. See also → 19, "Rotating the housing".
- Endress+Hauser offers a mounting bracket for installation on pipes or walls. See also → 16, "Wall and pipe mounting (optional)".

4.4.1 Installation instructions for devices without diaphragm seals – PMP71, PMC71

NOTICE

Damage to the device!

If a heated Cerabar S is cooled during the cleaning process (e.g. by cold water), a vacuum develops for a short time, and as a result, moisture can enter the sensor through the pressure compensation (1).

► Mount the device as follows.

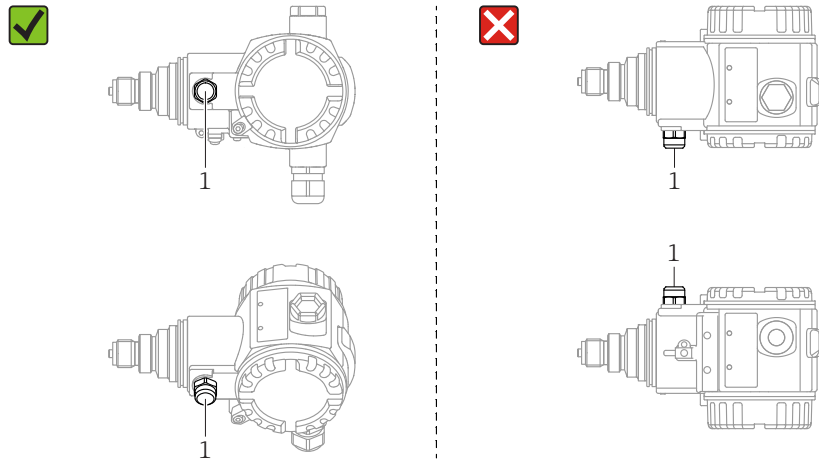

- Keep the pressure compensation and GORE-TEX® filter (1) free from contamination and water.
- Cerabar S devices without diaphragm seals are mounted in accordance with the same guidelines as a manometer (DIN EN 837-2). We recommend the use of shutoff devices and siphons. The orientation depends on the measuring application.
- Do not clean or touch process membranes with hard or pointed objects.
- The device must be installed as follows in order to comply with the cleanability requirements of the ASME-BPE (Part SD Cleanability):

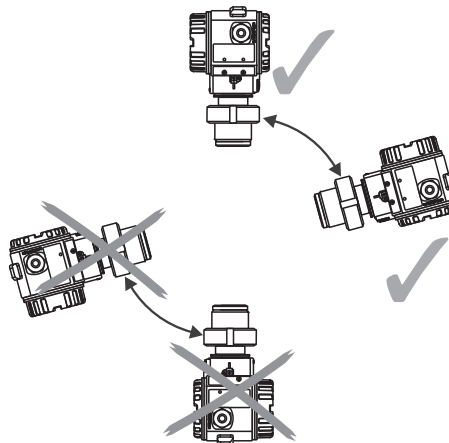

Pressure measurement in gases

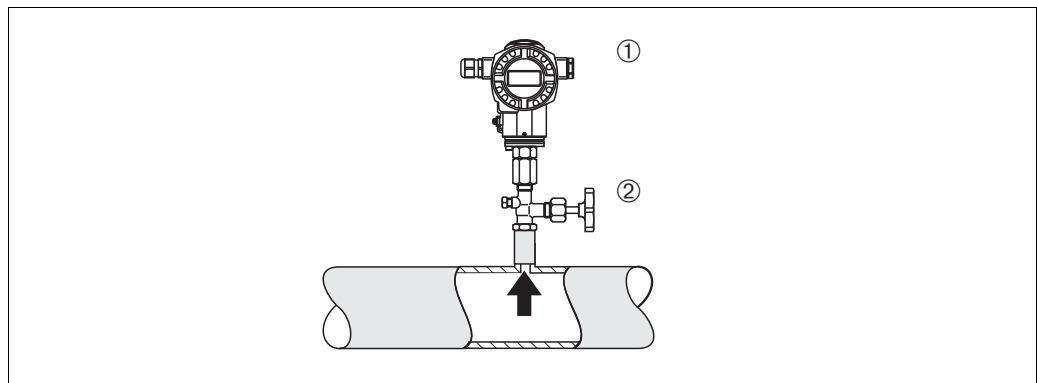

Fig. 1: Measuring arrangement for pressure measurement in gases

- 1 Cerabar S
- 2 Shutoff device

P01-PMx7xxxx-11-xx-xx-xx-001

Mount the Cerabar S with shutoff device above the tapping point so that any condensate can flow into the process.

Pressure measurement in steams

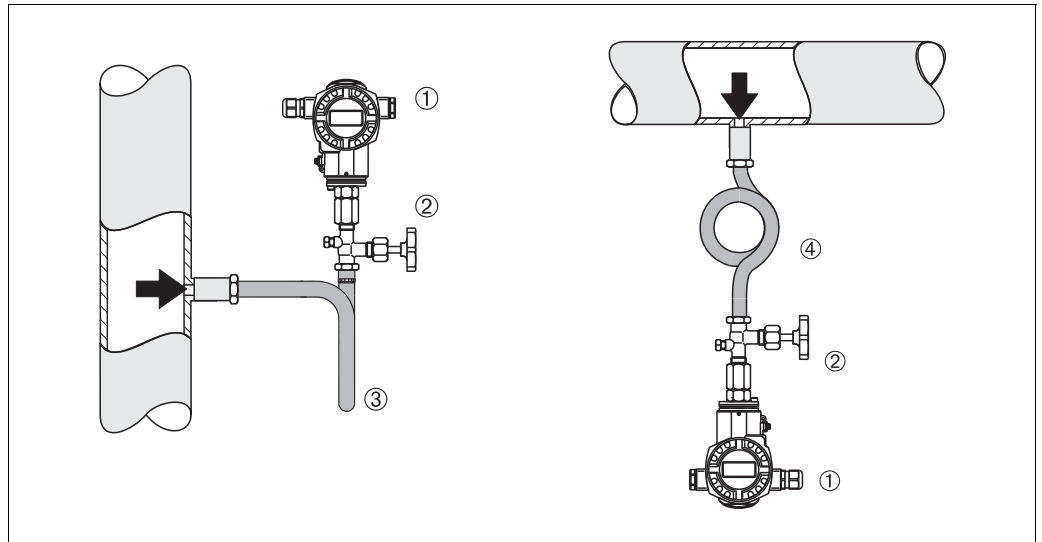

Fig. 2: Measuring arrangement for pressure measurement in steams

- 1 Cerabar S
- 2 Shutoff device
- 3 U-shaped siphon
- 4 Circular siphon

Observe the maximum permitted ambient temperature of the transmitter!

Mounting:

- Preferably mount the device with an O-shaped siphon below the tapping point
The device may also be mounted above the tapping point
- Fill the siphon with liquid before commissioning

Advantages of using siphons:

- Protection of the measuring instrument from hot, pressurized media by forming and accumulating condensate
- Damping of pressure shocks
- The defined water column only causes minimal (negligible) measurement errors and minimal (negligible) thermal effects on the device

For technical data (e.g. materials, dimensions or order numbers), see the accessory document SD01553P.

Pressure measurement in liquids

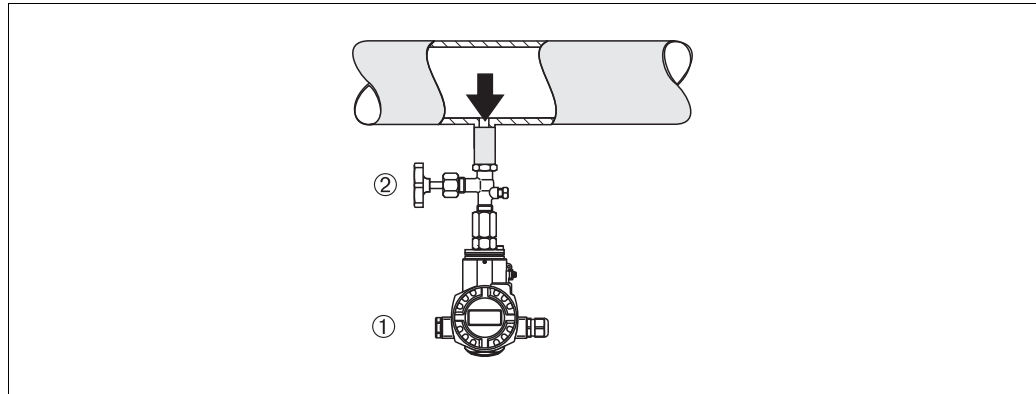

Fig. 3: Measuring arrangement for pressure measurement in liquids

- 1 Cerabar S
2 Shutoff device

Mount the Cerabar S with the shutoff device below or at the same level as the tapping point.

Level measurement

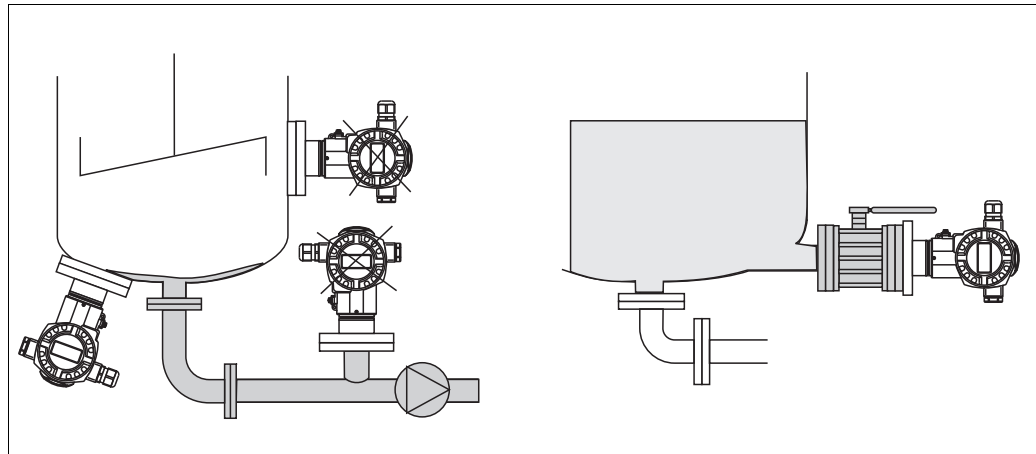

Fig. 4: Measuring arrangement for level

- Always install the Cerabar S below the lowest measuring point.
- Do not mount the device in the fill flow, or at a point in the tank which could be affected by pressure pulses from an agitator.
- Do not mount the device in the suction area of a pump.
- The adjustment and functional test can be carried out more easily if you mount the device downstream from a shutoff device.

4.4.2 Installation instructions for devices with diaphragm seals – PMP75

- Cerabar S devices with diaphragm seals are screwed in, flanged or clamped on, depending on the type of diaphragm seal.
- Please note that the hydrostatic pressure of the liquid columns in the capillaries can cause zero point shift. The zero point shift can be corrected.
- Do not clean or touch the process membrane of the diaphragm seal with hard or pointed objects.
- Do not remove the protection on the process membrane until just before installation.

NOTICE**Incorrect handling!**

Damage to the device!

- ▶ The diaphragm seal and the pressure sensor together form a closed, calibrated system which is filled with filling fluid through a hole in the upper part. This hole is sealed and not to be opened.
- ▶ When using a mounting bracket, sufficient strain relief must be ensured for the capillaries in order to prevent the capillary bending down (bending radius ≥ 100 mm (3.94 in)).
- ▶ Please observe the application limits of the diaphragm seal fill fluid as detailed in the Technical Information for Cerabar S TI00383P, "Planning instructions for diaphragm seal systems" section.

NOTICE

In order to obtain more precise measurement results and to avoid a defect in the device, mount the capillaries as follows:

- ▶ Mount capillaries vibration-free (in order to avoid additional pressure fluctuations)
- ▶ Do not mount in the vicinity of heating or cooling lines
- ▶ Insulate the capillaries if the ambient temperature is below or above the reference temperature
- ▶ With a bending radius of ≥ 100 mm (3.94 in)
- ▶ Do not use the capillaries as a carrying aid for the diaphragm seals!

Vacuum application

See Technical Information.

Mounting with temperature isolator

See Technical Information.

4.4.3 Seal for flange mounting**NOTICE****Incorrect measurement results.**

The seal is not allowed to press against the process membrane as this could affect the measurement result.

- ▶ Ensure that the seal is not touching the process membrane.

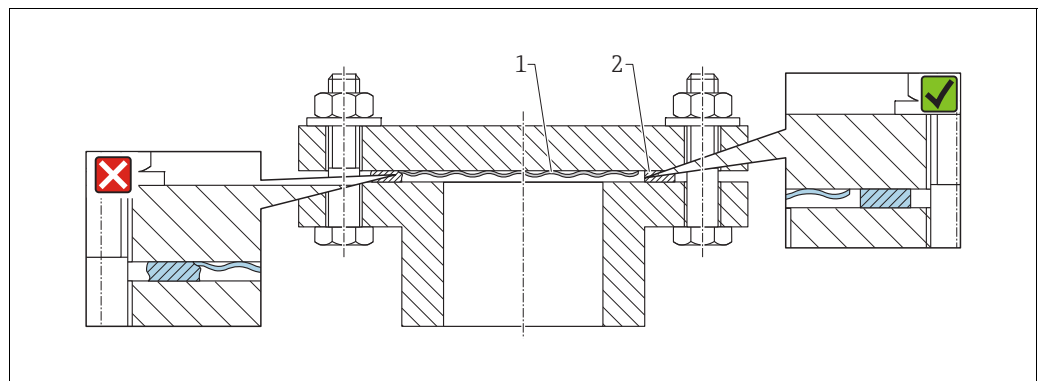

Fig. 5:

- 1 Process membrane
- 2 Seal

4.4.4 Heat insulation – PMC71 high temperature version and PMP75

See Technical Information.

4.4.5 Wall and pipe mounting (optional)

Endress+Hauser offers a mounting bracket for installation on pipes or walls (for pipe diameters from 1 ¼" to 2").

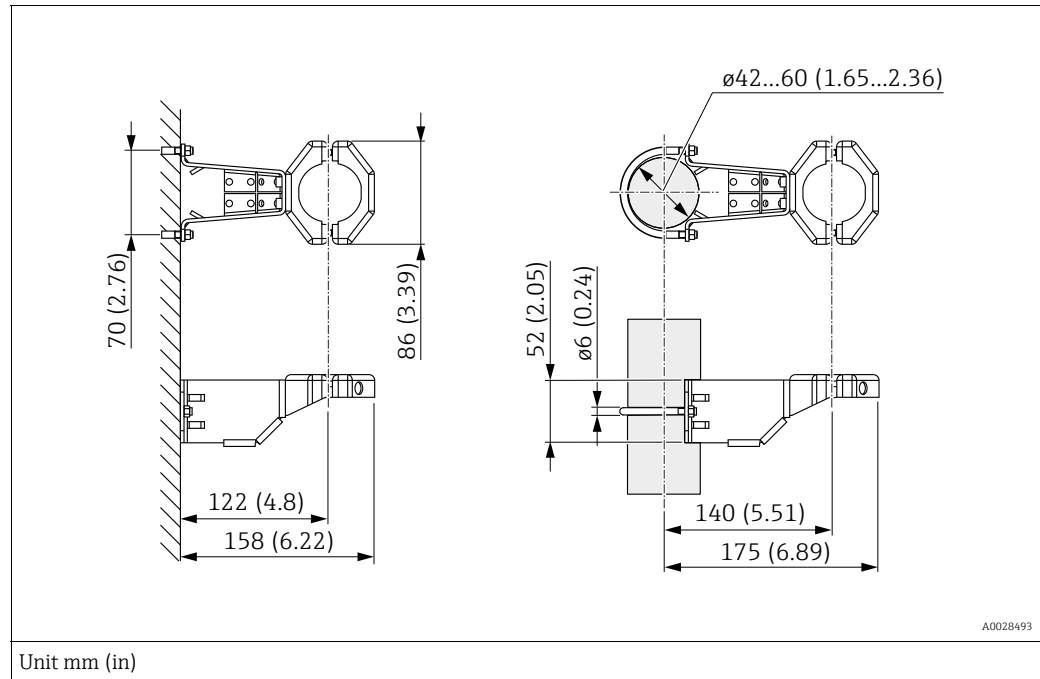

Please note the following when mounting:

- Devices with capillaries: mount capillaries with a bending radius ≥ 100 mm (3.94 in).
- When mounting on a pipe, tighten the nuts on the bracket uniformly with a torque of at least 5 Nm (3.69 lbs ft).

4.4.6 Assembling and mounting the "separate housing" version

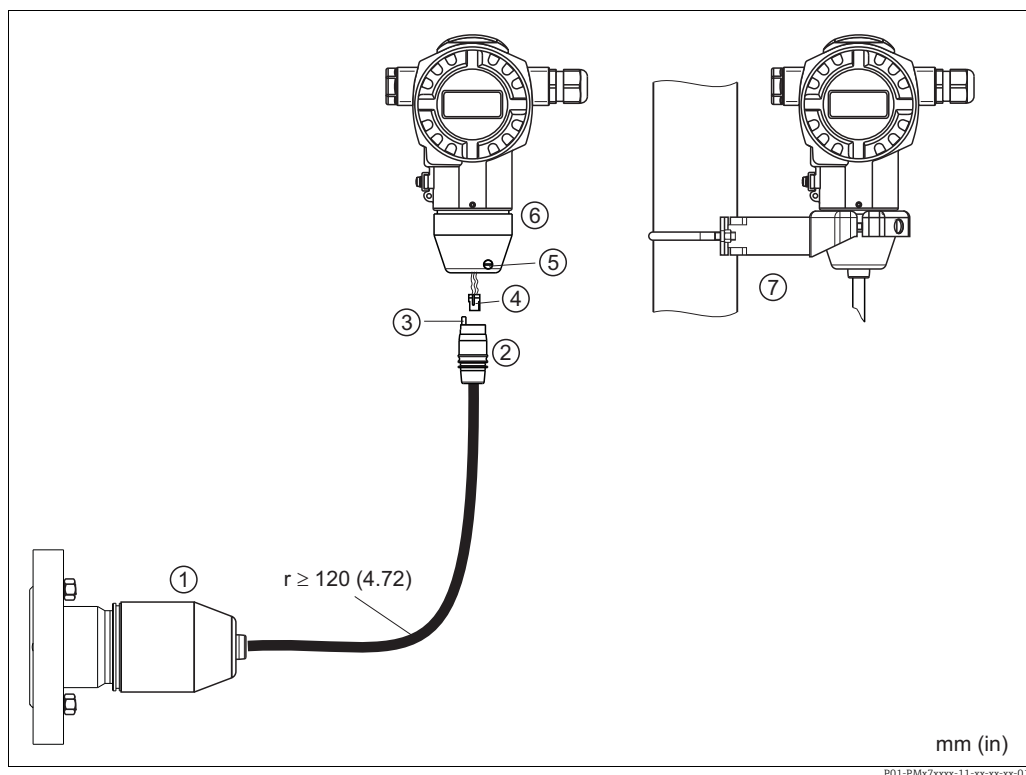

Fig. 6: "Separate housing" version

- 1 In the "separate housing" version, the sensor is supplied with process connection and cable fitted.
- 2 Cable with connection jack
- 3 Pressure compensation
- 4 Plug
- 5 Locking screw
- 6 Housing fitted with housing adapter, included
- 7 Mounting bracket suitable for wall and pipe mounting, included

Assembly and mounting

1. Connect plug (item 4) into the corresponding connection jack of the cable (item 2).
2. Plug the cable into the housing adapter (item 6).
3. Tighten the locking screw (item 5).
4. Mount the housing on a wall or pipe using the mounting bracket (item 7).
When mounting on a pipe, tighten the nuts on the bracket uniformly with a torque of at least 5 Nm (3.69 lbf ft).
Mount the cable with a bending radius (r) \geq 120 mm (4.72 in).

4.4.7 PMP71, version prepared for diaphragm seal mount – welding recommendation

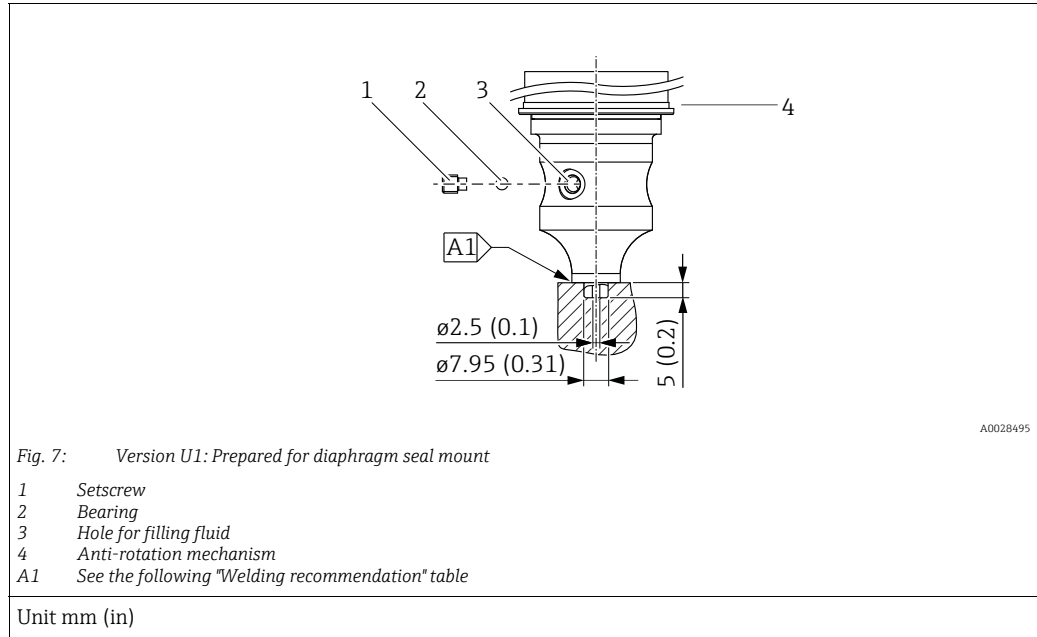

In the "U1" version, the anti-rotation mechanism (4) on the housing is not mounted at the factory but is enclosed. Fit the anti-rotation mechanism (4) after mounting the diaphragm seal.

Welding recommendation

For the "U1 Prepared for diaphragm seal mount" version, in feature 70 "Process connection; Material" in the order code up to, and including, 40 bar sensors (600 psi), Endress+Hauser recommends welding on the diaphragm seals as follows: the total welding depth of the fillet weld is 1 mm (0.04 in) at an external diameter of 16 mm (0.63 in). Welding is performed according to the WIG method.

Consecutive seam no.	Sketch/welding groove shape, dimension as per DIN 8551	Base material matching	Welding method DIN EN ISO 24063	Welding position	Inert gas, additives
A1 for sensors ≤ 40 bar (600 psi)		Adapter made of 316L (1.4435) to be welded to diaphragm seal made of 316L (1.4404/1.4435)	141	PB	Inert gas Ar/H 95/5 Additive: 1.4430 (ER 316L Si)

Information on filling

The diaphragm seal must be filled as soon as it has been welded on.

- Once it is welded into the process connection, the sensor assembly must be properly filled with a fill fluid and sealed gas-tight with a sealing ball and lock screw. Once the diaphragm seal has been filled, at the zero point the device display should not exceed 10% of the full scale value of the cell measuring range. The internal pressure of the diaphragm seal must be corrected accordingly.
- Adjustment / calibration:
 - The device is operational once it has been fully assembled.
 - Perform a reset. The device must then be calibrated to the process measuring range as described in the Operating Instructions.

4.4.8 Rotating the housing

The housing can be rotated by up to 380° by loosening the setscrew.

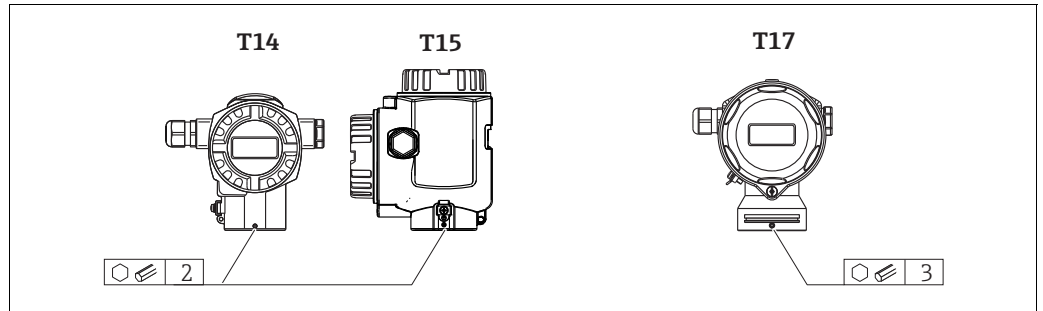

A0019996

1. T14 housing: loosen the setscrew with a 2 mm (0.08 in) Allen key.
T15 and T17 housing: loosen the setscrew with a 3 mm (0.12 in) Allen key.
2. Rotate the housing (max. up to 380°).
3. Retighten the setscrew with 1 Nm (0.74 lbf ft).

4.4.9 Closing the housing covers

NOTICE

Devices with EPDM cover seal - leaking transmitter!

Mineral-, animal- or plant-based lubricants cause the EPDM cover seal to swell and the transmitter to leak as a result.

- ▶ It is not necessary to grease the thread due to the coating applied to the thread at the factory.

NOTICE

The housing cover can no longer be closed.

Damaged thread!

- ▶ When closing the housing cover, please ensure that the thread of the cover and housing are free from dirt, e.g. sand. If you encounter resistance when closing the covers, then check the threads again for dirt or fouling.

Closing the cover on a hygienic stainless steel housing (T17)

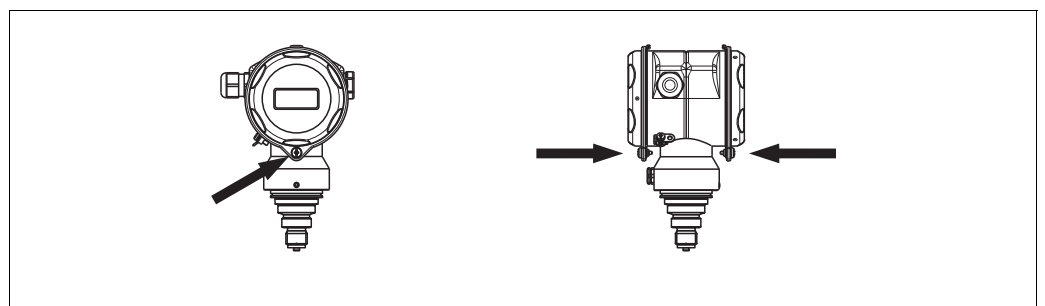

P01-PMx/xxxx-17-xx-xx-xx-002

Fig. 8: Closing the cover

The covers for the terminal compartment and electronics compartment are hooked into the housing and closed with a screw in each case. These screws should be finger-tightened (2 Nm (1.48 lbf ft)) to the stop to ensure that the covers sit tightly.

4.5 Post-installation check

After installing the device, carry out the following checks:

- Are all screws firmly tightened?
- Are the housing covers screwed down tight?

5 Wiring

5.1 Connecting the device

⚠ WARNING

Risk of electric shock!

If the operating voltage is > 35 VDC: Dangerous contact voltage at terminals.

- ▶ In a wet environment, do not open the cover if voltage is present.

⚠ WARNING

Electrical safety is compromised by an incorrect connection!

- Risk of electric shock and/or explosion! Switch off the supply voltage before connecting the device.
- When using the measuring instrument in hazardous areas, installation must also comply with the applicable national standards and regulations and the Safety Instructions or Installation or Control Drawings.
- Devices with integrated overvoltage protection must be grounded.
- Protective circuits against reverse polarity, HF influences, and overvoltage peaks are integrated.
- The supply voltage must match the supply voltage on the nameplate.
- Switch off the supply voltage before connecting the device.
- Remove housing cover of the terminal compartment.
- Guide cable through the gland. For cable specification see → 23, "Cable specification". Tighten the cable glands or cable entries so that they are leak-tight. Counter-tighten the housing entry. Use a suitable tool with width across flats SW24/25 (8 Nm (5.9 lbf ft) for the M20 cable gland.
- Connect the device as indicated in the following diagram.
- Screw down housing cover.
- Switch on the supply voltage.

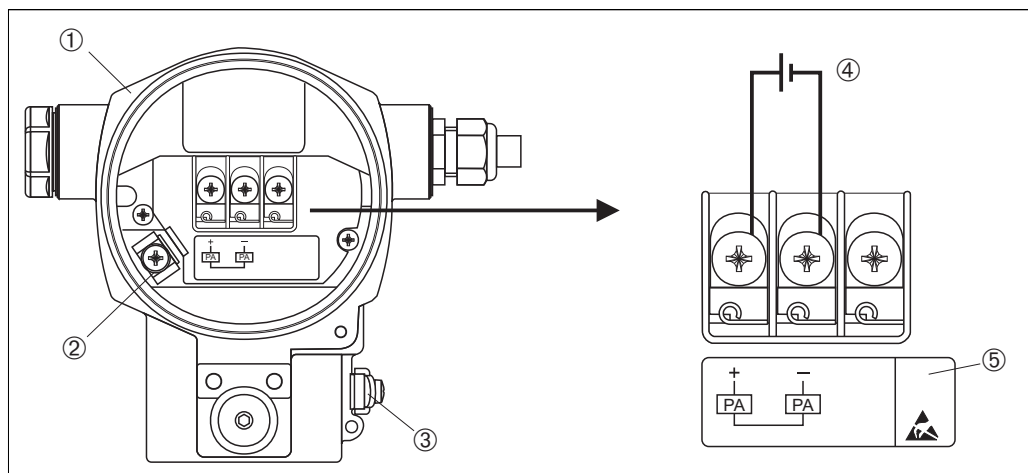
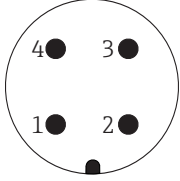

Fig. 9: Electrical connection of PROFIBUS PA
Please refer also to → 22, "Supply voltage".

- 1 Housing
- 2 Internal ground terminal
- 3 External ground terminal
- 4 Supply voltage, for version in non-hazardous area = 9 to 32 V DC
- 5 Devices with integrated overvoltage protection are labeled OVP (overvoltage protection) here.

5.1.1 Connection of devices with M12 plug

PIN assignment for M12 plug	PIN	Meaning
	1	Signal +
	2	Not assigned
	3	Signal -
	4	Earth

5.1.2 Devices with 7/8" plug

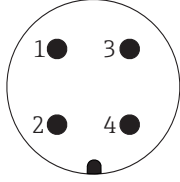
PIN assignment for 7/8" plug	PIN	Meaning
	1	Signal -
	2	Signal +
	3	Not assigned
	4	Shielding

5.1.3 Cable version connection

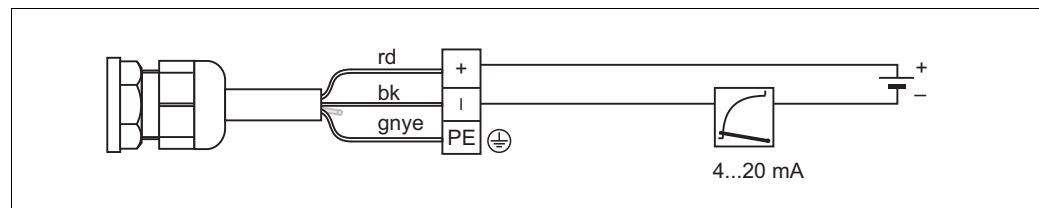

Fig. 10: rd = red, bk = black, gnye = green/yellow

P01-PMz4xxxx-04-xx-xx-xx-010

5.2 Connecting the measuring unit

For further information on the network structure and grounding and for further bus system components such as bus cables, see the relevant documentation, e.g. Operating Instructions BA00034S "Guidelines for planning and commissioning PROFIBUS DP/PA" and the PNO Guideline.

5.2.1 Supply voltage

⚠ WARNING

Supply voltage might be connected!

Risk of electric shock and/or explosion!

- ▶ When using the measuring instrument in hazardous areas, installation must also comply with the applicable national standards and regulations and the Safety Instructions or Installation or Control Drawings.
- ▶ All explosion protection data are provided in separate Ex documentation, which is available on request. The Ex documentation is supplied as standard with all devices approved for use in explosion hazardous areas.

Version for non-hazardous areas: 9 to 32 V DC

5.2.2 Current consumption

Up to HW Version 1.10: 11 mA \pm 1 mA, switch-on current corresponds to IEC 61158-2, Clause 21.

As of HW Version 02.00: 13 mA \pm 1 mA, switch-on current corresponds to IEC 61158-2, Clause 21.

As of Hardware Version 1.10, you will find a label on the electronic insert in the device.

5.2.3 Terminals

- Supply voltage and internal ground terminal: 0.5 to 2.5 mm² (20 to 14 AWG)
- External ground terminal: 0.5 to 4 mm² (20 to 12 AWG)

5.2.4 Cable specification

- Use a twisted, shielded twin-core cable, preferably cable type A.
- Outer cable diameter: 5 to 9 mm (0.2 to 0.35 in)

For further information on the cable specifications, see Operating Instructions BA00034S "Guidelines for planning and commissioning PROFIBUS DP/PA", PNO Guideline 2.092 "PROFIBUS PA User and Installation Guideline" and IEC 61158-2 (MBP).

5.2.5 Grounding and shielding

The Cerabar S must be grounded, for example by means of the external ground terminal.

Different grounding and shielding installation methods are available for PROFIBUS PA networks such as:

- Isolated installation (see also IEC 61158-2)
- Installation with multiple grounding
- Capacitive installation.

5.3 Overvoltage protection (optional)

NOTICE

Device could be destroyed!

Devices with integrated overvoltage protection must be grounded.

Devices showing option "M" in feature 100 "Additional options 1" or feature 110 "Additional options 2" in the order code are equipped with overvoltage protection (→ see also Technical Information TI00383P "Ordering information").

- Overvoltage protection:
 - Nominal functioning DC voltage: 600 V
 - Nominal discharge current: 10 kA
- Surge current check $\hat{i} = 20$ kA satisfied as per DIN EN 60079-14: 8/20 μ s
- Arrester AC current check $I = 10$ A satisfied

5.4 Post-connection check

Perform the following checks after completing the electrical installation of the device:

- Does the supply voltage match the specification on the nameplate?
- Is the device properly connected?
- Are all screws firmly tightened?
- Are the housing covers screwed down tight?

As soon as voltage is applied to the device, the green LED on the electronic insert lights up for a few seconds or the connected on-site display lights up.

6 Operation

Feature 20 "Output; operation" in the order code provides you with information on the operating options available to you.

Version in the order code		Operation
M	PROFIBUS PA; external and LCD	Via on-site display and 1 key on the exterior of the device
N	PROFIBUS PA; internal and LCD	Via on-site display and 1 key on the inside of the device
O	PROFIBUS PA; internal	Without on-site display, 1 key on the inside of the device

6.1 On-site display (optional)

A 4-line liquid crystal display (LCD) is used for display and operation. The on-site display shows measured values, fault messages and notice messages. The display of the device can be turned in 90° steps. Depending on the orientation of the device, this makes it easy to operate the device and read the measured values.

Functions:

- 8-digit measured value display including sign and decimal point, unit display.
- Bar Graph as graphic display of standardized value of the Analog Input Block (see also graphic, → 67, "Scaling OUT value").
- Simple and complete menu guidance thanks to separation of the parameters into several levels and groups.
- Menu guidance in 8 languages (de, en, fr, es, it, nl, jp, ch)
- Each parameter is given a 3-digit ID number for easy navigation.
- Option for configuring the display according to individual requirements and desires, such as language, alternating display, contrast setting, display of other measured values such as sensor temperature.
- Comprehensive diagnostic functions (fault and warning message).
- Rapid and safe commissioning with the Quick Setup menus.

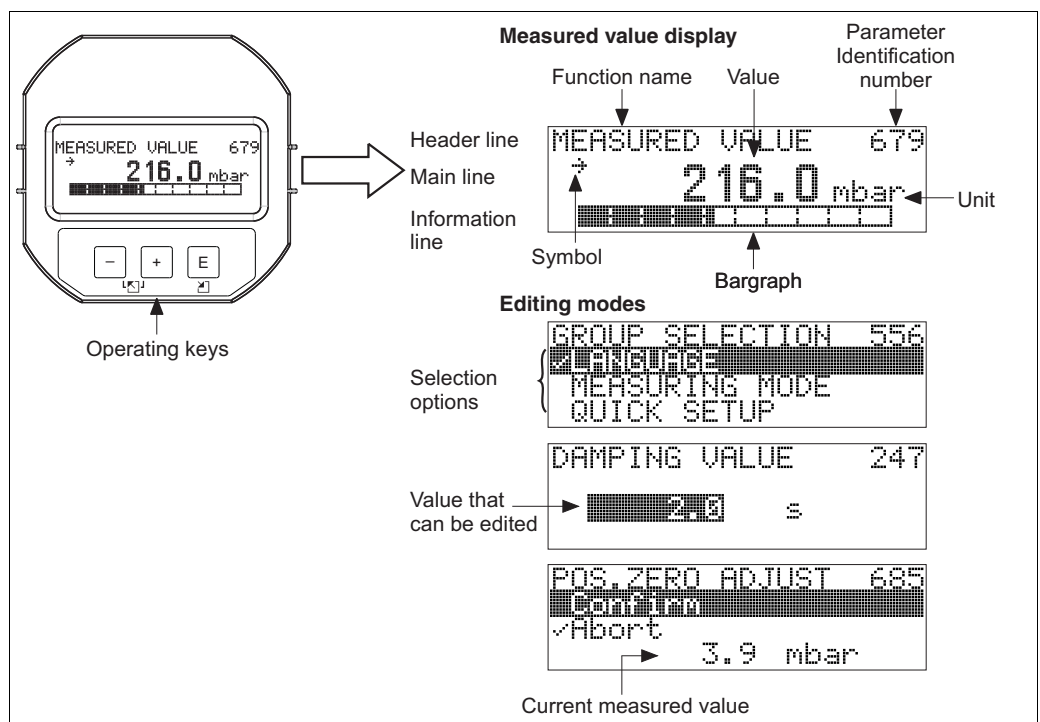

P01-xxxxxxx-07-xx-xx-xx-011

The following table illustrates the symbols that can appear on the on-site display. Four symbols may appear at the same time.

Symbol	Meaning
	Alarm symbol - Symbol flashing: warning, device continues measuring. - Symbol permanently lit: error, device does not continue measuring. <i>Note:</i> The alarm symbol may overlie the tendency symbol.
	Lock symbol The operation of the device is locked. Unlock device, see → 53, "Locking/unlocking operation".
	Communication symbol Data transfer via communication.
	Tendency symbol (increasing) The primary value of the Transducer Block is increasing.
	Tendency symbol (decreasing) The primary value of the Transducer Block is decreasing.
	Tendency symbol (constant) The primary value of the Transducer Block has remained constant over the past few minutes.

6.2 Operating elements

6.2.1 Position of operating elements

With regard to aluminum and stainless steel housings (T14), the operating key is located either outside the device under the protective cap or inside on the electronic insert. In hygienic stainless steel housings (T17), the operating key is always located inside on the electronic insert. In addition, there are three operating keys on the optional on-site display.

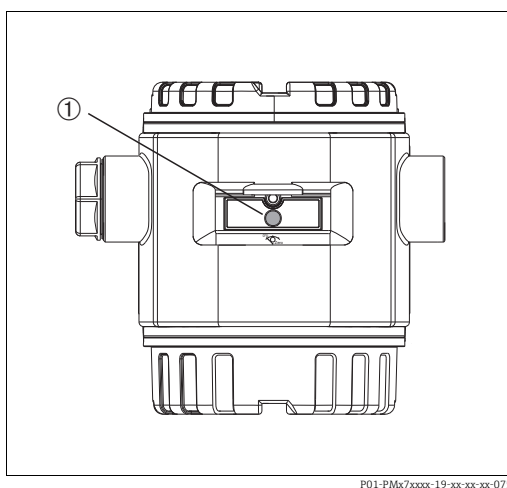

P01-PMx7xxxx-19-xx-xx-xx-075

Fig. 11: Operating key external, under the protective cap

- 1 Operating key for position adjustment (zero point correction) and total reset

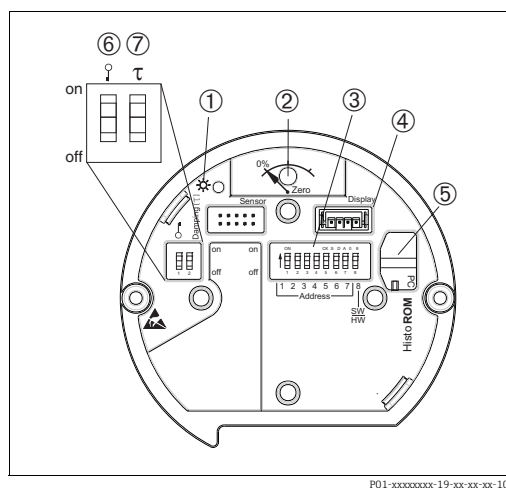

P01-xxxxxxx-19-xx-xx-xx-105

Fig. 12: Operating keys, internal

- 1 Green LED to indicate value being accepted
- 2 Operating key for position adjustment (zero point correction) and total reset
- 3 DIP switch for hardware address
- 4 Slot for optional display
- 5 Slot for optional HistoROM®/M-DAT
- 6 DIP switch for locking/unlocking measured value-related parameters
- 7 DIP switch for damping on/off

6.2.2 Function of operating elements

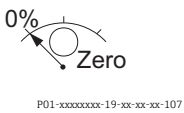
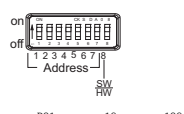
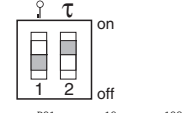
Operating elements	Meaning
 <p>P01-xxxxxxxx-19-xx-xx-xx-107</p>	<ul style="list-style-type: none"> – Position adjustment (zero point correction): Press key for at least 3 seconds. If the LED on the electronic insert lights up briefly, the pressure applied has been accepted for position adjustment. See also the following section "Performing on-site position adjustment". – Total reset: Press key for at least 12 seconds. The LED on the electronic insert lights up briefly if a reset is being carried out.
 <p>P01-xxxxxxxx-19-xx-xx-xx-109</p>	<p>Set the address in the bus. See also → 31, "Device identification and addressing".</p>
 <p>P01-xxxxxxxx-19-xx-xx-xx-108</p>	<ul style="list-style-type: none"> – DIP switch 1: for locking/unlocking measured value-related parameters. Factory setting: off (unlocked). See also → 53, "Locking/unlocking operation". – DIP switch 2: damping on/off. Factory setting: on (damping on)





Performing on-site position adjustment

- Operation must be unlocked. See → 53, "Locking/unlocking operation".
- The device is configured for the "Pressure" measuring mode as standard. You can switch measuring modes by means of the MEASURING MODE parameter. See → 58, "Selecting the language and measuring mode".
- The pressure applied must be within the nominal pressure limits of the sensor. See information on the nameplate.

Perform position adjustment:

1. Pressure is present at the device.
2. Press key for at least 3 seconds.
3. If the LED on the electronic insert lights up briefly, the pressure applied has been accepted for position adjustment.
If the LED does not light up, the pressure applied was not accepted. Observe the input limits. For error messages, see → 70, "Messages".

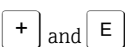
6.2.3 Function of operating elements – on-site display connected

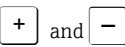
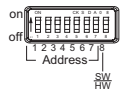
Operating key(s)	Meaning
	<ul style="list-style-type: none"> - Navigate upwards in the picklist - Edit the numerical values or characters within a function
	<ul style="list-style-type: none"> - Navigate downwards in the picklist - Edit the numerical values or characters within a function
	<ul style="list-style-type: none"> - Confirm entry - Jump to the next menu item
	<p>Contrast setting of on-site display: darker</p>
	<p>Contrast setting of on-site display: brighter</p>
	<p>ESC functions:</p> <ul style="list-style-type: none"> - Exit the editing mode without saving the modified value - You are in a menu within a function group. The first time you press the keys simultaneously, you go back a parameter within the function group. Each time you press the keys simultaneously after that, you go up a level in the menu. - You are in the menu at a selection level: each time you press the keys simultaneously, you go up a level in the menu. <p><i>Note:</i> The terms function group, level and selection level are explained → 48, "Menu structure".</p>
 <p style="font-size: small; margin-top: 5px;">P01-xxxxxxxx-19-xx-xx-xx-109</p>	<p>Set the address in the bus. See also → 31, "Device identification and addressing".</p>

6.3 PROFIBUS PA communication protocol

6.3.1 System architecture

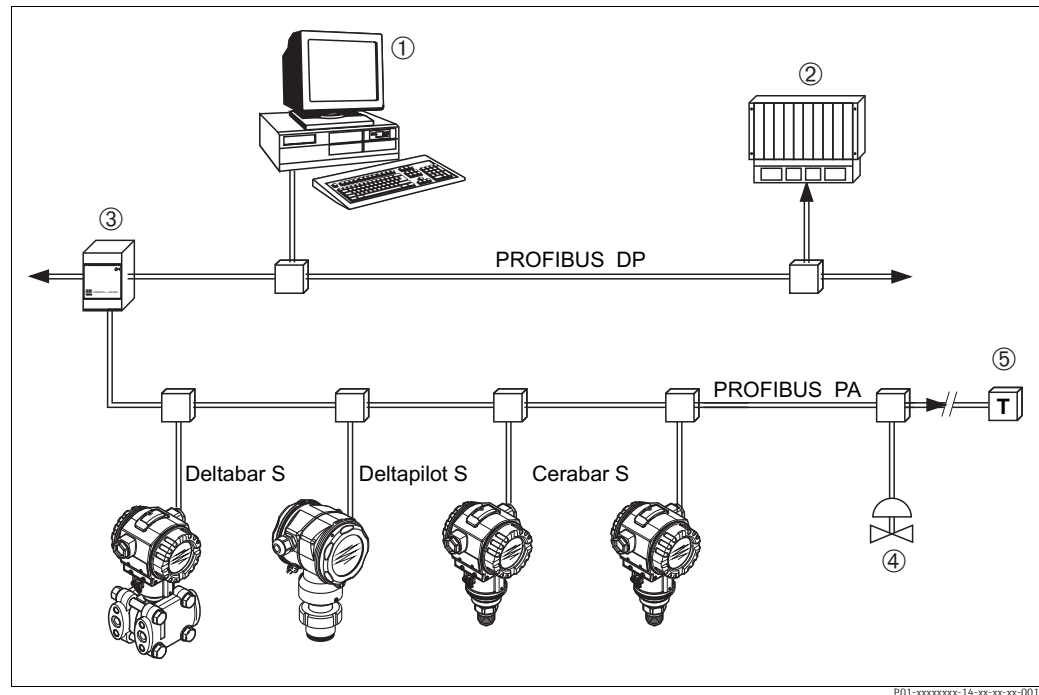

Fig. 13: PROFIBUS system architecture

- 1 PC with PROFIBUS interface card (Profiboard/Proficard) and FieldCare operating program (Class 2 master)
- 2 PLC (Class 1 master)
- 3 Segment coupler (DP/PA signal converter and bus feed unit)
- 4 Other measuring instruments and adjusters such as valves
- 5 PROFIBUS PA terminating resistor

Further information on PROFIBUS PA can be found in Operating Instructions BA00034S "Guidelines for planning and commissioning PROFIBUS DP/PA", the PNO Guideline and standards IEC 61158, IEC 61784, EN 50170/DIN 19245 and EN 50020 (FISCO model).

6.3.2 Number of devices

- The Endress+Hauser Cerabar S devices meet the requirements of the FISCO model.
- Due to the low current consumption, the following can be operated at one bus segment when installation is performed according to FISCO

Up to HW Version 1.10:

- Up to 9 Cerabar S devices for Ex ia, CSA and FM IS applications
- Up to 32 Cerabar S devices in all other applications, e.g. in non-Ex areas, Ex nA etc.

As of HW Version 02.00:

- Up to 7 Cerabar S devices for Ex ia, CSA and FM IS applications
- Up to 27 Cerabar S devices in all other applications, e.g. in non-Ex areas, Ex nA etc.

The maximum number of measuring instruments at one bus segment is defined by their current consumption, the performance of the bus coupler, and the required bus length.

As of Hardware Version 1.10, you will find a label on the electronic insert in the device.

6.3.3 Operation

Special configuration and operating programs from various manufacturers are available for configuring the device, such as the Endress+Hauser operating program FieldCare (see → 51, "Endress+Hauser operating program"). This operating program makes it possible to configure the PROFIBUS PA and device-specific parameters. The predefined function blocks allow uniform access to network and device data.

6.3.4 Identification number of the device

The "IDENT NUMBER SEL" parameter allows users to modify the identification number. The "IDENT NUMBER SEL" identification number must support the following settings:

Values for "IDENT NUMBER SEL."	Description
0 "0x9700"	Profile-specific transmitter identification number with the "Classic" or "Condensed" status.
1 "0x1541"	Identification number of the new Cerabar S generation (PMC71, PMP71, PMP75).
127 "Auto. Id. Num."	Device adaptation mode (the device can communicate using a variety of identification numbers), see "Smart device management" (automatic smart device management).
128 "0x1501"	Compatibility mode for the old Cerabar S generation (PMC731, PMP731, PMC631, PMP635).

The "Automatic Identification Number Selection" (value = 127) for Profile 3.02 is described in the section on smart device management (automatic smart device management). The choice of identification number affects the status and diagnostic messages ("Classic" or "Condensed"). "Old" identification numbers work with the "Classic" status and old diagnostic messages.

Depending on the configuration data of the user or the behavior selected in the COND.STATUS DIAG "Physical" block parameter, new identification numbers and the profile identification number work with either the "Condensed" or "Classic" status.

The identification number can only be changed if no cyclic communication is taking place with the device.

Cyclic data transmission and the corresponding identification number of the device remain the same until cyclic transmission is aborted and reestablished or the device is shut down. When reestablishing cyclic data transmission the device uses the last identification number. The choice of identification number also determines how many modules are assigned during cyclic communication. All blocks are internally instantiated in advance for all the devices but only the configured modules can be accessed depending on the entries in the device master data.

Table of the function blocks:

"IDENT NUMBER SEL" parameter	0 (Profile-specific)	128 (Old identification number)	127 (Auto. identification number)	1 (New identification number)
Cerabar S	3 blocks (PB, TB, AI)	...	Depends on the identification number automatically selected.	3 Blocks (PB, TB, AI)
	1 module (1x AI)	...		1 module (1x AI)

Table of the identification numbers:

Value for "IDENT NUMBER SEL"	Identification number	Selection text	Status	Diagnostics
0 (Profile-specific 3.x)	0x9700	0x9700	Classic status / Condensed status	New diagnostic messages
128 (Old identification number)	0x1501	0x1501	Classic status	Old diagnostic messages
127 (Adaptation mode)	0x9700/0x1501/ 0x1541	Auto. identification number "Auto ID. Num."	Depends on ID numbers	Depends on ID numbers
1 (New identification number)	0x1541	0x1541	Classic status / Condensed status	New diagnostic messages

Smart device management (automatic smart device management)

Smart PA device management is performed by automatically adapting the device identification number. This makes it possible to replace old devices with new models without having to modify the PLC, allowing the transition from an installed device technology to a more sophisticated technology without interrupting the process.

With the "Automatic Identification Number Selection" option, the device behavior and rules (diagnostics, cyclic communication etc.) remain the same as those for a static identification number. The identification number is selected automatically depending on the recognized request frame -"Set Slave Parameter" or "Set Slave Address".

It is permitted to change the identification number in two specific device transition states, namely in the adaptation mode and only if the identification number is listed in the table above.

If the identification number is undefined and the selector is set to "Auto ID. Num." following a "Get Slave Diagnosis" frame, the device returns an identification number diagnostic value which is compatible with the device. After every new "Get Slave Diagnose" frame, the device returns another identification number that is compatible with the device until the PLC sends a "Set Slave Address" or "Set Slave Parameter" frame with a known identification number.

6.3.5 Device identification and addressing

Note the following:

- An address must be assigned to every PROFIBUS PA device. Only when the address is configured correctly will the measuring instrument be recognized by the control system/master.
- Each address may only be assigned once in each PROFIBUS PA network.
- Valid device addresses are in the range from 0 to 125.
- The address 126 which is set at the factory can be used to check the function of the device and to connect to a PROFIBUS PA network that is in operation. This address must be changed subsequently to add additional devices.
- All devices have the address 126 and software addressing on leaving the factory.
- The FieldCare operating program is delivered with the address 0 (default setting).

There are two ways to assign the device address to a Cerabar S:

- Via an operating program of the DP Class 2 master, such as FieldCare or
- On site using the DIP switches.

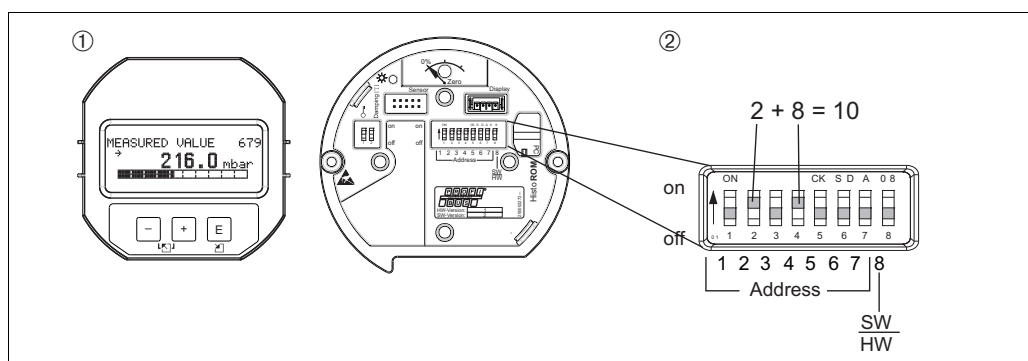

Fig. 14: Setting the device address using the DIP switches

- 1 If necessary, remove the (optional) on-site display
- 2 Set the hardware address via the DIP switches

Hardware addressing

Hardware addressing is configured as follows:

1. Set DIP switch 8 (SW/HW) to "Off".
2. Set the address with DIP switches 1 to 7 (see figure above).
3. You have to wait 10 seconds for a change in address to take effect. The device is restarted.

DIP switch	1	2	3	4	5	6	7
Weighting in "On" position	1	2	4	8	16	32	64
Weighting in "Off" position	0	0	0	0	0	0	0

Software addressing

Software addressing is configured as follows:

1. Set DIP switch 8 (SW/HW) to "On" (factory setting)
2. The device is restarted.
3. The device reports its current address. Factory setting: 126
4. Configure the address via the configuration program.
See the next section for information on how to enter a new address via FieldCare. For other operating programs, please refer to the relevant Operating Instructions.

Configuring a new address via FieldCare. DIP switch 8 (SW/HW) is set to "On" (SW):

1. Using the "Device Operation" menu → select the "Connect" option. The "Open Connection Wizard" screen is displayed.
2. The device reports its current address. Factory setting: 126 ¹⁾
3. The device has to be disconnected from the bus before you can assign the device a new address. For this purpose, select the "Disconnect" option in the → "Device Operation" menu.
4. Using the "Device Operation" menu → "Device Functions" → "Additional Functions" → select "Set Device Station Address". The "PROFIdtm DPV1 (Set Device Station address)" screen is displayed.
5. Enter the new address and confirm with "Set".
6. The new address is assigned to the device.

1) The address 126 is not adjustable via the menu. After a reset (code 2712) the address is stored as a default address in the device.

6.3.6 System integration

Device master data (GSD files)

The device is ready for system integration following commissioning via the Class 2 master (FieldCare). To integrate the field devices into the bus system, the PROFIBUS PA system requires a description of the device such as device identification, ID number, supported communication features, module structure (combination of cyclic input and output telegrams) and meaning of diagnosis bits.

These data are contained in a Device Master File (GSD file) which is placed at the disposal of the PROFIBUS DP master (e.g. PLC) while the communication system is being commissioned. Device bitmaps, which appear as icons in the network tree, can also be integrated.

The following versions of GSD are possible when using devices that support the "PA devices" profile:

- Manufacturer-specific GSD, ID number: 0x1541:
This GSD ensures unrestricted functionality of the field device.
All device-specific process parameters and functions are available.
- Manufacturer-specific GSD, ID number: 0x1501:
The device behaves like a Cerabar S PMC731, PMP731, PMC631, PMP635.
See Operating Instructions BA00168P.
- Profile GSD:
As an alternative to the manufacturer-specific GSD, the PNO makes a general database file available with the name PA139700.gsd for devices with an Analog Input Block. This file supports the transmission of the primary value. The transmission of a 2nd cyclic value or a display value is not supported. If a system is commissioned with the profile GSDs, devices of different manufacturers can be exchanged.

The following Device Master Files (GSD) can be used with the Cerabar S:

Name of device	Comments	ID number (IDENT_NUMBER_SELECT) ¹⁾	GSD	Type file	Bit map
Cerabar S PROFIBUS PA	Profile GSD	0x9700	PA139700.gsd		
	Device-specific GSD	0x1541 ²⁾	EH3x1541.gsd EH021541.gsd ³⁾		EH_1541_d.bmp/.dib EH_1541_n.bmp/.dib EH_1541_s.bmp/.dip
	Device-specific GSD, the device behaves like a Cerabar S PMC731, PMP731, PMC631, PMP635. See Operating Instructions BA00168P.	0x1501 ²⁾	EH3_1501.gsd EH3x1501.gsd	EH31501x.200	EH_1501_d.bmp/.dib EH_1501_n.bmp/.dib EH_1501_s.bmp/.dip

- 1) Select the corresponding ID number by means of the IDENT NUMBER SEL parameter
menu path FieldCare: PROFILE VIEW → PHYSICAL BLOCK → PB PARAMETER
menu path on-site display: GROUP SELECTION → OPERATING MENU → TRANSMITTER INFO → PA DATA.
- 2) Each device receives an ID number from the Profibus User Organization (PNO). The name of the Device Master File (GSD) is derived from this. For Endress+Hauser, this ID No. starts with the manufacturer ID "15xx".
- 3) The Profile 3.02 GSD file with the "Condensed status" option is only compatible with SW 04.01.zz and must be imported individually into the configuration tool.

The "IDENT NUMBER SEL" parameter can only be changed if either the device is not integrated into the cyclic communication (not planned in the PLC) or the cyclic communication of the PLC is at Stop. If an attempt is nevertheless made to change the parameter via a configuration software program, such as FieldCare, the entry is ignored.

The Device Master Files (GSD) for Endress+Hauser devices can be acquired in the following manner:

- Endress+Hauser website: <http://www.endress.com> → Downloads → Search for "GSD"
- PNO website: <http://www.profibus.com> (Products – Product Guide)
- On CD-ROM from Endress+Hauser, order number: 56003894

The profile device master data (GSD files) of the PNO can be acquired as follows:

- PNO website: <http://www.profibus.com> (Products – Profile GSD Library)

Directory structure of GSD files from Endress+Hauser

For Endress+Hauser field devices with PROFIBUS PA interface, all the data which are needed for configuration are contained in a compressed file. After unpacking the file, the following structure is generated:

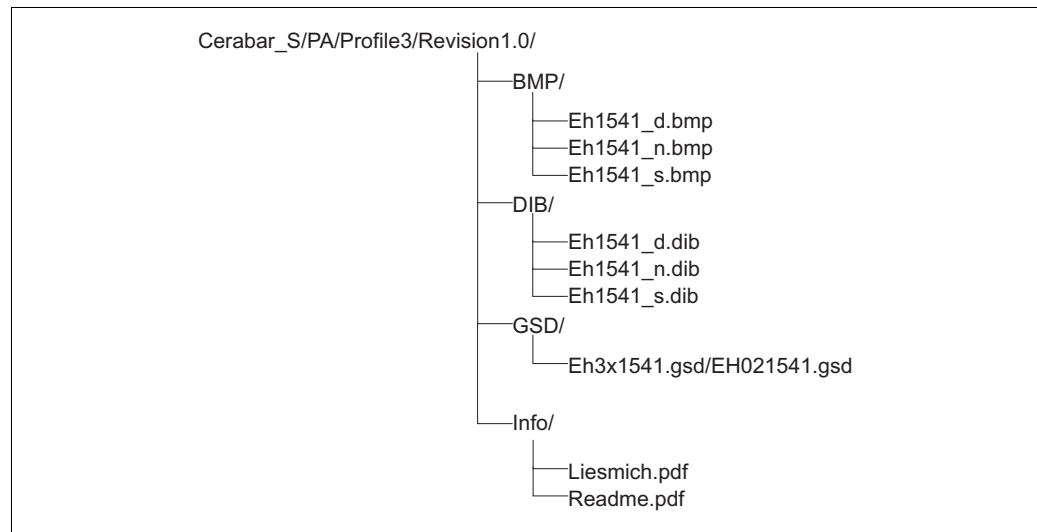

Fig. 15: Directory structure of GSD 1541

P01-PMx7xxxx-02-xx-xx-xx-003

- Revision x.x stands for the corresponding device version.
- Information relating to the implementation of the field transmitter and any dependencies in the device software can be found in the "Info" folder. Read this information carefully before configuring.
- Device-specific bitmaps can be found in the "BMP" and "DIB" directories. The utilization of these will depend on the configuration software that is being used.

Working with Device Master Files (GSD)

The Device Master Files (GSD) must be integrated into a specific subdirectory of the PROFIBUS DP configuration software of the PLC used. Depending on the software used, these files can be either copied to the program-specific directory or imported into the database using an import function in the configuration software.

Detailed information on the directories to which the Device Master Files (GSD) are to be saved is provided in the description of the configuration software used.

6.3.7 Cyclic data exchange

Cerabar S block model

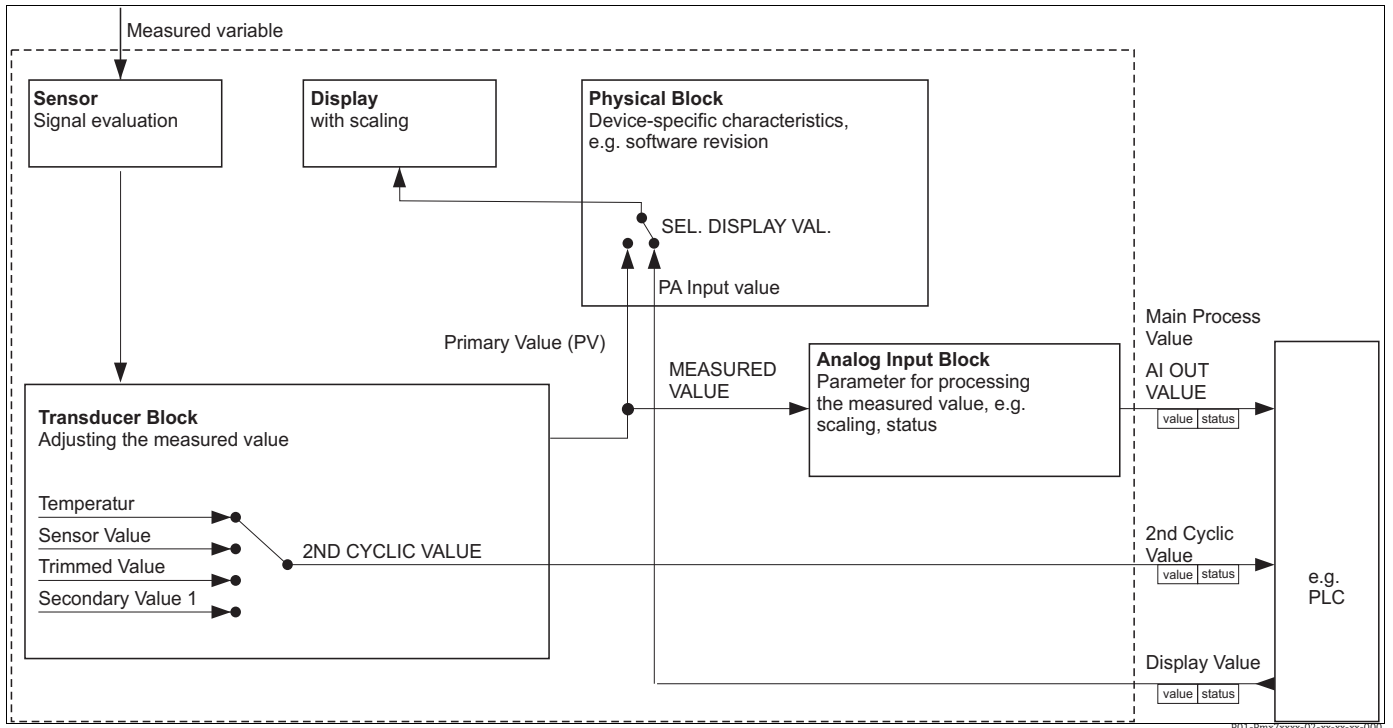

Fig. 16: The block model shows what data can be transmitted between the Cerabar S and the Class 1 master (e.g. PLC) during cyclic data exchange. Using the configuration software of your PLC, compile the cyclic data telegram with the aid of modules (see also "Modules for the cyclic data diagram" in this section). The parameters, written in CAPS, are parameters in the operating program (e.g. FieldCare) which you can use to make settings for the cyclic data telegram or to display values (see also "Parameter description" in this section).

Cerabar S function blocks

PROFIBUS uses predefined function blocks to describe the function blocks of a device and to specify uniform data access.

The following blocks are implemented in the Cerabar S:

- **Physical Block:**
The Physical Block contains device-specific features such as the device type, manufacturer, version etc. as well as functions such as write protection management and ID number switching
- **Transducer Block:**
The transducer block contains all the measuring and device-specific parameters of the device. The Cerabar S Transducer Block contains the pressure measuring principle for use as a pressure and level transmitter.
- **Analog Input Block (function block):**
The Analog Input Block contains the signal processing functions of the measured value such as scaling, special function calculations, simulation etc.

Parameter description

Parameter name	Description
OUT VALUE	<p>This parameter shows the digital output value of the Analog Input Block.</p> <p>Menu path FieldCare: PROFILE VIEW → ANALOG INPUT BLOCK → AI PARAMETER</p> <p>Menu path on-site display: GROUP SELECTION → OPERATING MENU → TRANSMITTER INFO → PA DATA</p>
PA INPUT VALUE	<p>This value is transmitted from the PLC to the Cerabar S. The PA INPUT VALUE can be displayed on the on-site display (see also this table, SEL. DISPLAY VAL.).</p> <p>Menu path FieldCare: PROFILE VIEW → PHYSICAL BLOCK → PB PARAMETER</p> <p>Menu path on-site display: GROUP SELECTION → OPERATING MENU → TRANSMITTER INFO → PA DATA</p>
SEL.DISPLAY VAL.	<p>Use this parameter to specify whether the primary value or a value of the PLC is shown on the on-site display.</p> <p>Menu path FieldCare: MANUFACTURER VIEW → OPERATING MENU → DISPLAY or PROFILE VIEW → PHYSICAL BLOCK → PB PARAMETER → PROFIBUS PA CONF</p> <p>Menu path on-site display: GROUP SELECTION → OPERATING MENU → TRANSMITTER INFO → PA DATA</p> <p>Options:</p> <ul style="list-style-type: none"> ▪ Primary value (PV): the primary value is shown on the on-site display. ▪ Input value: a value from the PLC is displayed on the on-site display (see this table, PA INPUT VALUE). <p>Example for the "Input value" option:</p> <ul style="list-style-type: none"> ▪ Two Cerabar S devices measure the pressure drop by means of a filter. The differential pressure is formed in the PLC. Use the "Input value" option to assign this calculated value to the on-site display. <p>Factory setting:</p> <ul style="list-style-type: none"> ▪ Primary value (PV)
2ND CYCLIC VALUE	<p>Use this parameter to specify which value is transmitted via the bus as the second cyclic value.</p> <p>Menu path FieldCare: PROFILE VIEW → PHYSICAL BLOCK → PB PARAMETER → PROFIBUS PA CONF</p> <p>Menu path on-site display: GROUP SELECTION → OPERATING MENU → TRANSMITTER INFO → PB PARAMETER → PROFIBUS PA CONF</p> <p>Options:</p> <ul style="list-style-type: none"> ▪ Temperature ▪ Sensor value: corresponds to the SENSOR PRESSURE parameter ▪ Trimmed value: corresponds to the CORRECTED PRESS. parameter ▪ Secondary value 1: corresponds to the PRESSURE parameter <p>The SENSOR PRESSURE, CORRECTED PRESSURE and PRESSURE parameters are displayed in the PROCESS VALUES menu (menu path: MANUFACTURER VIEW → OPERATING MENU → PROCESS INFO → PROCESS VALUES).</p> <p>The TEMPERATURE parameter is displayed in the TB PARAMETER menu (menu path: PROFILE VIEW → TRANSDUCER BLOCK → TB PARAMETER)</p> <p>Factory setting:</p> <ul style="list-style-type: none"> ▪ Temperature

Modules for the cyclic data diagram

Cerabar S makes the following modules available for the cyclic data diagram:

- Main process value
Depending on the operating mode selected, a pressure or level value is transmitted here.
- 2ND CYCLIC VALUE
Depending on the option selected, a temperature, the sensor value, trimmed value or secondary value 1 is transmitted here.
- Display value
This is any value that is transmitted from the PLC to the Cerabar S. This value can also be shown on the on-site display.
- FREE PLACE
Select this empty module if a value should not be used in the data telegram.

Structure of the output data PLC → Cerabar S

With the Data_Exchange service, a PLC can read output data from the Cerabar S in the call telegram. The cyclic data telegram has the following structure:

Index output data	Data	Access	Data format/comments
0, 1, 2, 3	Display value	Write	32 bit floating point number (IEEE 754)
4	Status code	Write	See "Status codes" section

Structure of the input data Cerabar S → PLC

With the Data_Exchange service, a PLC can read input data from the Cerabar S in the response telegram. The cyclic data telegram has the following structure:

Index input data	Data	Access	Data format/comments
0, 1, 2, 3	Main process value: pressure or level	Read	32 bit floating point number (IEEE 754)
4	Status code for main process value	Read	See "Status codes"
5, 6, 7, 8	2ND CYCLIC VALUE: temperature, sensor value, trimmed value or secondary value 1	Read	32 bit floating point number (IEEE 754)
9	Status code for 2ND CYCLIC VALUE	Read	See "Status codes"

Status codes

Cerabar S supports the "Condensed status" function as defined in the PNO specification. However, the "Classic" status is also supported to ensure compatibility with older devices in the S series and due to the profile-specific identification number ("0x9700").

If the profile number and new identification number are selected, the status type can be set via the "COND.STATUS DIAG" parameter.

The "Condensed" and/or "Classic" status and their current active states are displayed by the "Physical Block" in the "Feature" parameter. The measuring instrument supports the following status codes for the output value parameters of the Analog Input Block:

Classic status:

Status code	Device status	Meaning	Output value (OUT value) (Analog Input)	2ND CYCLIC VALUE
0000 0000	Bad	Not specific	X ¹⁾	X
0000 0100	Bad	Configuration error (e.g. adjustment not performed correctly)	X ¹⁾	X
0000 1100	Bad	Device error	X ¹⁾	X
0001 0000	Bad	Sensor error	X ¹⁾	X
0001 1100	Bad	Out of service (target mode)	X	X
0100 0000	Uncertain	Not specific	X	X
0100 0100	Uncertain	Last valid value (failure behavior = 1)	X	X
0100 1000	Uncertain	Substitute value (failure behavior = 0)	X	X
0100 1100	Uncertain	Initial value (failure behavior = 1)	X	X
0101 1100	Uncertain	Configuration error (e.g. linearization table not increasing monotonically)	X	X
0101 0011	Uncertain	Sensor conversion not accurate - constant	X	X
0101 0010	Uncertain	Sensor conversion - limit value exceeded	X	X
0101 0001	Uncertain	Sensor conversion - limit value undershot	X	X
0110 0000	Uncertain	Simulation value	X	X
1000 0000	GOOD	Good	X	X
1000 1000	GOOD	Warning limit	X	X
1000 1001	GOOD	Warning limit - limit value exceeded	X	X
1000 1010	GOOD	Warning limit - limit value undershot	X	X
1000 1100	GOOD	Alarm limit	X	X
1000 1101	GOOD	Alarm limit - limit value exceeded	X	X
1000 1110	GOOD	Alarm limit - limit value undershot	X	X

1) Only if the analog input failure behavior = 2 ("Status BAD")

Condensed status:

The main reason for implementing the "Condensed" status mode in the Profibus PA Profile 3.02 is to clarify the diagnostic events resulting from use in the PCS/DCS and in the operating station.

Furthermore, this functionality also implements the requirements of NE 107.

The following "Condensed" status codes are configured via the device.

Status code ¹⁾	Device status	Meaning	Output value (OUT value) (Analog Input 1)	2ND CYCLIC VALUE
0010 01xx	Bad ²⁾	Maintenance alarm, advanced diagnostics present	X ³⁾	X
0010 10xx	Bad ²⁾	Process error, no maintenance required	X ³⁾	X
0011 11xx	Bad ²⁾	Function check / local override	X ³⁾	X
0010 0011	Bad ²⁾	Switch off	X	X
0111 1011	UNCERTAIN (Uncertain)	Process error, no maintenance required - limit value constant	X	X
0111 1010	UNCERTAIN (Uncertain)	Process error, no maintenance required - limit value exceeded	X	X
0111 1001	UNCERTAIN (Uncertain)	Process error, no maintenance required - limit value undershot	X	X
0111 1000	UNCERTAIN (Uncertain)	Process error, no maintenance required	X	X
0110 10xx	UNCERTAIN (Uncertain)	Maintenance required	X	X
0100 1011	UNCERTAIN (Uncertain)	Substitute value	X	
0100 1111	UNCERTAIN (Uncertain)	Initial value	X	
0111 0011	UNCERTAIN (Uncertain)	Simulated value, start	X	X
0111 0100	UNCERTAIN (Uncertain)	Simulated value, end	X	
1000 0000	GOOD	Good	X	X
1011 1100	GOOD	Function check	X	X
1010 01xx	GOOD	Maintenance required	X	X
1010 10xx	GOOD	Maintenance required	X	X

1) Variable x: 0 or 1

2) See → Kap. 9.2.1

3) Only if the analog input failure behavior = 2 ("Status BAD")

6.3.8 Acyclic data exchange

Acyclic data exchange is used:

- To transmit commissioning or maintenance parameters
- To display measured variables not contained in the cyclic data diagram.

Using acyclic data exchange, device parameters can be modified even when the device is involved in cyclic data exchange with a PLC.

There are two types of acyclic data exchange:

- Acyclic communication via the C2 channel (MS2)
- Acyclic communication via the C1 channel (MS1)

Acyclic communication via the C2 channel (MS2)

When communicating via the C2 channel, a master opens a communication channel by means of a service access point (SAP) to access the device. A master that supports acyclic communication via the C2 channel is called a Class 2 master. FieldCare, for example, is a Class 2 master.

All the device parameters have to be made known to the master before data can be exchanged via PROFIBUS.

The following options are available here:

- A configuration program in the master which accesses the parameters via slot and index addresses (e.g. FieldCare)
- A software component (DTM: Device Type Manager)
 - The DTM can be found on the FieldCare CD.
 - The number of Class 2 masters that can simultaneously communicate with a device is restricted to the number of SAPs available for this communication. Cerabar S supports MS2 communication with two SAPs. Here, you must make certain that they do not both attempt to write-access the same data, since otherwise the data consistency cannot be guaranteed.
- Using the C2 channel for acyclic data exchange increases the cycle times of the bus system. This should be taken into account when programming the control system.

Acyclic communication via the C1 channel (MS1)

With acyclic communication via the C1 channel, a master that is already communicating cyclically with the device also opens an acyclic communication channel via SAP 0x33 (special SAP for MS1). The master can then acyclically read or write the parameters like a Class 2 master via slot and index addresses. Cerabar S supports MS1 communication with one SAP.

NOTICE

Shortening the lifetime of the device!

Parameters written acyclically are written to memory modules (EEPROM, Flash, etc.). These are resistant to voltage. The memory modules are only designed for a limited number of writes which is not even remotely reached in normal operation without MS1 (during configuration). This figure can be quickly exceeded as a result of incorrect programming and thus the operating time of a device can be drastically reduced.

- ▶ In the application program, avoid constantly writing parameters, e.g. for every cycle of the program.

6.3.9 Slot/index tables

The device parameters are listed in the following tables. You can access the parameters by means of the slot and index number. The individual blocks each contain standard parameters, block parameters and manufacturer-specific parameters. If you use FieldCare as the operating program, input screens are available as the user interface.

General explanatory remarks

Object type

- Record: contains data structure (DS)
- Array: group of a certain data type
- Simple: contains individual data types such as Float

Data type

- DS: data structure, contains data types such as Unsigned8, Octet String etc.
- Float: IEEE 754 format
- Integer:
 - Integer8: value range = -128 to 127
 - Integer16: value range = -32768 to 32767
 - Integer32: value range = -2^{31} to 2^{31}
- Octet String: binary coded
- Visible String: ASCII coded
- Unsigned:
 - Unsigned8: value range = 0 to 255
 - Unsigned16: value range = 0 to 65535
 - Unsigned32: value range = 0 to 4294967295

Storage Class

- Cst: constant parameter
- D: dynamic parameter
- N: non-volatile parameter
- S: static parameter

Device management

Parameter	Slot	Index	Object type	Data type	Size [byte]	Storage Class	Read	Write
Directory object header	1	0	Array	Unsigned16	12	Cst	x	
Composite list directory entries	1	1	Array	Unsigned16	24	Cst	x	
GAP directory continuous	1	2 – 8						
GAP reserved	1	9 – 15						

Physical Block

Parameter	Slot	Index	Object type	Data type	Size [byte]	Storage Class	Read	Write
Physical Block standard parameters								
BLOCK OBJECT	0	16	Record	DS-32	20	Cst	x	
STATIC REVISION NO.	0	17	Simple	Unsigned16	2	N	x	
TAG	0	18	Simple	Visible String	32	S	x	x
STRATEGY	0	19	Simple	Unsigned16	2	S	x	x
ALERT KEY	0	20	Simple	Unsigned8	1	S	x	x
TARGET MODE	0	21	Simple	Unsigned8	1	S	x	x
MODE BLK	0	22	Record	DS-37	3	D	x	
ALARM SUM	0	23	Record	DS-42	8	D	x	
Physical Block parameters								
SOFTWARE VERSION	0	24	Simple	Visible String	16	Cst	x	
HARDWARE REV.	0	25	Simple	Visible String	16	Cst	x	
MANUFACTURER ID	0	26	Simple	Unsigned16	2	Cst	x	
DEVICE NAME STR.	0	27	Simple	Visible String	16	Cst	x	
DEVICE SERIAL No.	0	28	Simple	Visible String	16	Cst	x	
DIAGNOSTICS	0	29	Simple	Octet String	4	D	x	
DIAGNOSIS EXTENSION	0	30	Simple	Octet String	6	D	x	
DEVICE CERTIFICATION	0	33	Simple	Visible String	32	Cst	x	
INSERT PIN No.	0	34	Simple	Unsigned16	2	N	x	x
ADDITIONAL INFO.	0	36	Simple	Visible String	32	S	x	x
USER DESCRIPTION	0	37	Simple	Visible String	32	S	x	x
INSTALLATION DATE	0	38	Simple	Visible String	16	S	x	x
IDENT NUMBER SEL	0	40	Simple	Unsigned8	1	S	x	x
DIP STATUS	0	41	Simple	Unsigned8	1	D	x	
FEATURE	0	42	Record	DS-68	8	N	x	
COND.STATUS DIAG	0	43	Simple	Unsigned8	1	S	x	x
Physical Block, Endress+Hauser parameters								
ALARM STATUS	0	54	Record	E+H specific	5	D	x	
LAST DIAG. CODE	0	55	Record	E+H specific	5	D	x	
UP/DOWNLOAD FEATURE	0	56	Simple	Unsigned8	1	Cst	x	
UP/DOWNLOAD CTRL	0	57	Simple	Unsigned8	1	D		x
UP/DOWN PARAM	0	58	Simple	OctetString	20	D	x	x
BUS ADDRESS	0	59	Simple	Unsigned8	1	D	x	
SET UNIT TO BUS	0	61	Simple	Unsigned8	1	S	x	x
PA INPUT VALUE	0	62	Record	E+H specific	6	D	x	x
SEL. DISPLAY VAL.	0	63	Simple	Unsigned8	1	S	x	x
PROFILE REVISION	0	64	Simple	Visible String	32	Cst	x	
RESET ALL ALARMS	0	65	Simple	Unsigned8	1	S	x	x
IDENT-NUMBER	0	66	Simple	Unsigned16	2	D	x	
2ND CYCLIC VALUE	0	68	Simple	Unsigned8	1	S	x	x
DEVICE DESIGN.	0	69	Simple	Visible String	32	S	x	
CONFIG RECORDER	0	74	Simple	Unsigned16	2	D	x	
OPERATING HOURS	0	75	Simple	Unsigned32	4	D	x	
SIM. ERROR NO.	0	76	Simple	Unsigned16	2	D	x	x
SIMULATE	0	77	Simple	Unsigned8	1	D	x	x
LANGUAGE	0	78	Simple	Unsigned8	1	N	x	x
DISPLAY CONTRAST	0	79	Simple	Unsigned8	1	S	x	x
MAIN LINE CONT.	0	80	Simple	Unsigned8	1	N	x	x
MAIN LINE FORMAT	0	81	Simple	Unsigned8	1	D	x	x
ALTERNATE DATA	0	82	Simple	Unsigned8	1	N	x	x
UNIT TEXT	0	83	Simple	Visible String	8	S	x	x
USER DESCRIPTION	0	84	Simple	Visible String	32	S	x	x
ACK. ALARM MODE	0	85	Simple	Unsigned8	1	S	x	x
ACK. ALARM	0	86	Simple	Unsigned8	1	D	x	x
SELECT ALARM TYPE	0	87	Simple	Unsigned8	1	S	x	x
ERROR NO.	0	88	Simple	Unsigned16	2	D	x	x
ALARM DELAY	0	89	Simple	Float	4	S	x	x
ALARM DISPL. TIME	0	90	Simple	Float	4	S	x	x
3RD CYCLIC VALUE	0	93	Simple	Unsigned8	1	S	x	x
HistoROM AVAIL.	0	94	Simple	Unsigned8	1	D	x	
HIST. SAVING CYCL	0	95	Simple	Unsigned8	1	S	x	x
HistoROM CONTROL	0	96	Simple	Unsigned8	1	S	x	x
ELECTR. SERIAL NO.	0	97	Simple	Visible String	32	Cst	x	

Parameter	Slot	Index	Object type	Data type	Size [byte]	Storage Class	Read	Write
PCB TEMPERATURE	0	98	Simple	Float	4	D	x	
Allowed Min.TEMP	0	99	Simple	Float	4	Cst	x	
Allowed Max. TEMP	0	100	Simple	Float	4	Cst	x	
PCB COUNT T>Tmax	0	101	Simple	Unsigned16	2	D	x	
PCB MAX. TEMP	0	102	Simple	Float	4	D	x	
PCB COUNT T<Tmin	0	103	Simple	Unsigned16	4	D	x	
PCB MIN. TEMP.	0	104	Simple	Float	4	D	x	
MAIN LINE FORMAT	0	106	Simple	Unsigned8	1	D	x	
DOWNLOAD FUNCT.	0	107	Simple	Unsigned8	1	N	x	x
STATUS LOCKING	0	108	Simple	Unsigned8	1	D	x	x
DEVICE STATUS	0	109	Simple	Unsigned8	1	S	x	
STATUS SELECT EVENT 727	0	110	Simple	Unsigned8	1	S	x	x
STATUS SELECT EVENT 115	0	111	Simple	Unsigned8	1	S	x	x
STATUS SELECT EVENT 120	0	112	Simple	Unsigned8	1	S	x	x
STATUS SELECT EVENT 731	0	113	Simple	Unsigned8	1	S	x	x
STATUS SELECT EVENT 730	0	114	Simple	Unsigned8	1	S	x	x
STATUS SELECT EVENT 733	0	115	Simple	Unsigned8	1	S	x	x
STATUS SELECT EVENT 732	0	116	Simple	Unsigned8	1	S	x	x
STATUS SELECT EVENT 726	0	117	Simple	Unsigned8	1	S	x	x
STATUS SELECT EVENT 715	0	118	Simple	Unsigned8	1	S	x	x
STATUS SELECT EVENT 719	0	119	Simple	Unsigned8	1	S	x	x
STATUS SELECT EVENT 717	0	120	Simple	Unsigned8	1	S	x	x
STATUS SELECT EVENT 718	0	121	Simple	Unsigned8	1	S	x	x
STATUS SELECT EVENT 740	0	122	Simple	Unsigned8	1	S	x	x
STATUS SELECT EVENT 716	0	123	Simple	Unsigned8	1	S	x	x
STATUS SELECT	0	124	Record	14xUnsigned8	14	S	x	x
SWITCH_STATUS_LIST	0	125	Record	2x Unsigned8	2	D	x	
SENSOR SER. No.	0	126	Simple	Visible String	16	S	x	

Analog Input Block

Parameter	Slot	Index	Object type	Data type	Size [byte]	Storage Class	Read	Write
Analog Input Block standard parameters								
BLOCK OBJECT	1	16	Record	DS-32	20	Cst	x	
STATIC REVISION NO.	1	17	Simple	Unsigned16	2	N	x	
TAG	1	18	Simple	Visible String	32	S	x	x
STRATEGY	1	19	Simple	Unsigned16	2	S	x	x
ALERT KEY	1	20	Simple	Unsigned8	1	S	x	x
TARGET MODE	1	21	Simple	Unsigned8	1	S	x	x
MODE BLK	1	22	Record	DS-37	3	D	x	
ALARM SUM	1	23	Record	DS-42	8	D	x	
Analog Input Block parameters								
BATCH	1	24	Record	DS-67	10	S	x	x
OUT	1	26	Record	DS-33	5	D	x	x ¹⁾
PV SCALE	1	27	Array	Float	8	S	x	x
OUT SCALE	1	28	Record	DS-36	11	S	x	x
LIN TYPE	1	29	Simple	Unsigned8	1	S	x	x
CHANNEL	1	30	Simple	Unsigned16	2	S	x	x
FILTER TIME CONST	1	32	Simple	Float	4	S	x	x
FAIL SAFE MODE	1	33	Simple	Unsigned8	1	S	x	x
FAIL SAFE DEFAULT VALUE	1	34	Simple	Float	4	S	x	x
LIMIT HYSTERESIS	1	35	Simple	Float	4	S	x	x
UPPER LIMIT ALARM	1	37	Simple	Float	4	S	x	x
UPPER LIMIT WARNING	1	39	Simple	Float	4	S	x	x
LOWER LIMIT WARNING	1	41	Simple	Float	4	S	x	x
LOWER LIMIT ALARM	1	43	Simple	Float	4	S	x	x
HI HI ALARM	1	46	Record	DS-39	16	D	x	
HI ALARM	1	47	Record	DS-39	16	D	x	
LO ALARM	1	48	Record	DS-39	16	D	x	
LO LO ALARM	1	49	Record	DS-39	16	D	x	
SIMULATE	1	50	Record	DS-50	6	S	x	x
VIEW_1_FB	1	61	Simple	Octet String	18	D	x	

1) If MODE_BLK Actual = Manual (MAN)

Transducer Block

Parameter	Slot	Index	Object type	Data type	Size [byte]	Storage Class	Read	Write
Transducer Block standard parameters								
BLOCK OBJECT	2	16	Record	DS-32	20	Cst	x	
STATIC REVISION NO.	2	17	Simple	Unsigned16	2	N	x	
TAG	2	18	Simple	Visible String	32	S	x	x
STRATEGY	2	19	Simple	Unsigned16	2	S	x	x
ALERT KEY	2	20	Simple	Unsigned8	1	S	x	x
TARGET MODE	2	21	Simple	Unsigned8	1	S	x	x
MODE BLK	2	22	Record	DS-37	3	D	x	
ALARM SUM	2	23	Record	DS-42	8	D	x	
SENSOR PRESSURE	2	24	Simple	Float	4	D	x	
PRESS.SENS HILIM	2	25	Simple	Float	4	N	x	
PRESS.SENS LOLIM	2	26	Simple	Float	4	N	x	
HIGH SENSOR TRIM	2	27	Simple	Float	4	S	x	x
LOW SENSOR TRIM	2	28	Simple	Float	4	S	x	x
MINIMUM SPAN	2	29	Simple	Float	4	N	x	
PRESS. ENG. UNIT	2	30	Simple	Unsigned16	2	S	x	
TRIMMED_VALUE (CORRECTED PRESS.)	2	31	Record	DS-33	5	D	x	
SENSOR MEAS. TYPE	2	32	Simple	Unsigned16	2	N	x	
SENSOR SER. No.	2	33	Simple	Unsigned32	4	N	x	
PRIMARY VALUE (MEASURED VALUE)	2	34	Record	DS-33	5	D	x	
PRIM_VALUE_UNIT	2	35	Simple	Unsigned16	2	S	x	x
PRIM_VALUE_TYPE	2	36	Simple	Unsigned16	2	S	x	x
DIAPHRAG.MAT.	2	37	Simple	Unsigned16	2	S	x	
FILLING FLUID	2	38	Simple	Unsigned16	2	S	x	
SEAL TYPE	2	40	Simple	Unsigned16	2	S	x	x
PROC.CONN.TYPE	2	41	Simple	Unsigned16	2	S	x	x
MAT.PROC.CONN. +	2	42	Simple	Unsigned16	2	S	x	x
TEMPERATURE (SENSOR TEMP.)	2	43	Record	DS-33	5	D	x	
TEMP. ENG. UNIT	2	44	Simple	Unsigned16	2	S	x	x
SEC_VALUE_1 (PRESSURE)	2	45	Record	DS-33	5	D	x	
SEC_VALUE1_UNIT	2	46	Simple	Unsigned16	2	S	x	x
SEC_VALUE_2	2	47	Record	DS-33	5	D	x	
SEC_VALUE2_UNIT	2	48	Simple	Unsigned16	2	S	x	x
LIN_TYP	2	49	Simple	Unsigned8	1	S	x	x
SCALE IN	2	50	Array	Float	8	S	x	x
SCALE OUT	2	51	Array	Float	8	S	x	x
LOW_FLOW_CUT_OFF	2	52	Simple	Float	4	S	x	x
FLOW_LIN_SQUARE	2	53	Simple	Float	4	S	x	x
TAB_ACTUAL_NUMB	2	54	Simple	Unsigned8	1	N	x	
LINE-NUMB:	2	55	Simple	Unsigned8	1	D	x	x
TAB_MAX_NR	2	56	Simple	Unsigned8	1	N	x	
TAB_MIN_NR	2	57	Simple	Unsigned8	1	N	x	
TAB_OP_CODE	2	58	Simple	Unsigned8	1	D	x	x
TAB_STATE	2	59	Simple	Unsigned8	1	D	x	
TAB_XY_VALUE	2	60	Array	Float	8	D	x	x
MAX. MEAS.PRESS.	2	61	Simple	Float	4	N	x	x ¹⁾
MIN. MEAS.PRESS.	2	62	Simple	Float	4	N	x	x ¹⁾
MAX. MEAS.TEMP.	2	63	Simple	Float	4	N	x	x ¹⁾
MIN. MEAS.TEMP.	2	64	Simple	Float	4	N	x	x ¹⁾
EMPTY CALIB.	2	75	Simple	Float	4	S	x	x
FULL CALIB.	2	76	Simple	Float	4	S	x	x
TANK CONTENT UNIT	2	77	Simple	Unsigned16	2	N	x	
UNIT FLOW	2	78	Simple	Unsigned16	2	N	x	x
DAMPING VALUE	2	79	Simple	Float	4	S	x	x
MAX FLOW	2	80	Simple	Float	4	S	x	x
MAX. PRESS. FLOW	2	81	Simple	Float	4	S	x	x
Pmin ALARM WINDOW	2	82	Simple	Float	4	S	x	x
Pmax ALARM WINDOW	2	83	Simple	Float	4	S	x	x
Tmin ALARM WINDOW	2	84	Simple	Float	4	S	x	x
Tmax ALARM WINDOW	2	85	Simple	Float	4	S	x	x
SIMULATED VALUE	2	86	Simple	Float	4	D	x	x
SIMULATE	2	87	Simple	Unsigned8	1	D	x	x
COUNTER P>Pmin	2	88	Simple	Unsigned16	2	D	x	
COUNTER P<Pmax	2	89	Simple	Unsigned16	2	D	x	
COUNTER T>Tmax	2	90	Simple	Unsigned16	2	D	x	

Parameter	Slot	Index	Object type	Data type	Size [byte]	Storage Class	Read	Write
COUNTER T < Tmin	2	91	Simple	Unsigned16	2	D	x	
MEAS. VAL. TREND	2	92	Simple	Unsigned8	1	D	x	
TOTALIZER 1	2	93	Simple	Visible String	8	D	x	
TOTAL. 1 OVERFLOW	2	94	Simple	Visible String	8	D	x	
TOTALIZER 2	2	95	Simple	Visible String	8	D	x	
TOTAL. 2 OVERFLOW	2	96	Simple	Visible String	8	D	x	
TEMP Abs RANGE	2	97	Simple	Float	4	Cst	x	
Tmin SENSOR	2	98	Simple	Float	4	Cst	x	
Tmax SENSOR	2	99	Simple	Float	4	Cst	x	
SENS H/WARE REV	2	100	Simple	Unsigned8	1	Cst	x	
Pmax PROC. CONN.	2	101	Simple	Float	4	S	x	x
TOTAL. 1 ENG. UNIT	2	102	Simple	Unsigned16	2	S	x	x
TOTAL. 2 ENG. UNIT	2	103	Simple	Unsigned16	2	S	x	x
FACT.U.U.TOTAL.1	2	104	Simple	Float	4	S	x	x
FACT.U.U.TOTAL.2	2	105	Simple	Float	4	S	x	x
TOT. 1 USER UNIT	2	106	Simple	Visible String	8	S	x	x
TOTALIZER 2 UNIT	2	107	Simple	Visible String	8	S	x	x
NEG. FLOW TOT. 1	2	108	Simple	Unsigned8	1	S	x	x
NEG. FLOW TOT. 2	2	109	Simple	Unsigned8	1	S	x	x
RESET TOTALIZER 1	2	110	Simple	Unsigned8	1	S	x	x
FLOW-MEAS. TYPE	2	111	Simple	Unsigned8	1	S	x	x
CUSTOMER UNIT F	2	112	Simple	Visible String	8	S	x	x
CUST.UNIT FACT.F	2	113	Simple	Float	4	S	x	x
CUSTOMER UNIT P	2	114	Simple	Visible String	8	S	x	x
CUST.UNIT FACT.P	2	115	Simple	Float	4	S	x	x
POS. ZERO ADJUST	2	116	Simple	Unsigned8	1	D	x	x
POS. INPUT VALUE	2	117	Simple	Float	4	S	x	x
CALIB. OFFSET	2	118	Simple	Float	4	S	x	x
TANK DESCRIPTION	2	119	Simple	Visible String	32	S	x	x
LIN. EDIT MODE	2	120	Simple	Unsigned8	1	N	x	x
CALIBRATION MODE	2	121	Simple	Unsigned8	1	S	x	x
ADJUST DENSITY	2	122	Simple	Float	4	N	x	
LEVEL UNIT TXT	2	123	Simple	Visible String	8	S	x	x
CUST.UNIT FACT.L	2	124	Simple	Float	4	S	x	x
CUST. UNIT CONT.	2	125	Simple	Visible String	8	S	x	x
FACTOR TANK CONT.	2	126	Simple	Float	4	S	x	x
DENSITY UNIT	2	127	Simple	Unsigned16	2	S	x	x
ADJUST DENSITY	2	128	Simple	Float	4	S	x	x
TANK VOLUME	2	129	Simple	Float	4	S	x	x
TANK HEIGHT	2	130	Simple	Float	4	S	x	x
100% POINT	2	131	Simple	Float	4	S	x	x
ZERO POSITION	2	132	Simple	Float	4	S	x	x
LEVEL MIN.	2	133	Simple	Float	4	S	x	x
LEVEL MAX.	2	134	Simple	Float	4	S	x	x
PROCESS DENSITY	2	135	Simple	Float	4	S	x	x
MAX TURNDOWN	2	136	Simple	Float	4	S	x	
SENSOR CHANGES	2	137	Simple	Unsigned16	2	S	x	
P PEAKHOLD.STEP	2	138	Simple	Float	4	S	x	
T PEAKHOLD.STEP	2	139	Simple	Float	4	S	x	
ACC. OF GRAVITY	2	140	Simple	Float	4	S	x	
CREEP FLOW HYST.	2	141	Simple	Float	4	S	x	
LEVEL BEFORE LIN.	2	142	Simple	Float	4	D	x	
ENG. UNIT LEVEL	2	145	Simple	Unsigned16	2	S	x	x
UNIT VOLUME	2	146	Simple	Unsigned16	2	S	x	x
CUSTOMER UNIT V	2	147	Simple	Visible String	8	S	x	x
CUST.UNIT FACT.V	2	148	Simple	Float	4	S	x	x
SET.L.FL.CUT-OFF	2	149	Simple	Float	4	S	x	x
MAT.PROC.CONN. -	2	150	Simple	Unsigned16	2	S	x	x
TANK CONTENT	2	151	Simple	Float	4	D	x	
SUPPRESSED FLOW	2	152	Simple	Float	4	D	x	
RESET PEAKHOLD	2	153	Simple	Unsigned8	1	D	x	x
MEASURING MODE	2	154	Simple	Unsigned8	1	S	x	x
UNIT FLOW	2	155	Simple	Unsigned16	2	S	x	x
TOTALIZER 1 UNIT (Volume operat. cond.)	2	156	Simple	Unsigned16	2	S	x	x
TOTALIZER 2 UNIT (Volume operat. cond.)	2	157	Simple	Unsigned16	2	S	x	x
LOW FLOW CUT-OFF	2	158	Simple	Unsigned8	1	S	x	x
LO TRIM MEASURED	2	159	Simple	Float	4	N	x	

Parameter	Slot	Index	Object type	Data type	Size [byte]	Storage Class	Read	Write
HI TRIM MEASURED	2	160	Simple	Float	4	N	x	
PERCENT UNIT	2	161	Simple	Unsigned16	2	Cst	x	x
X-VAL:	2	162	Simple	Float	4	N	x	x
Y-VAL:	2	163	Simple	Float	4	N	x	x
MASS FLOW UNIT	2	164	Simple	Unsigned16	2	S	x	x
SIM.FLOW VALUE	2	165	Simple	Float	4	D	x	x
STD. FLOW UNIT	2	166	Simple	Unsigned16	2	S	x	x
NORM FLOW UNIT	2	167	Simple	Unsigned16	2	S	x	x
TOTALIZER 1 UNIT (Mass p. cond.)	2	168	Simple	Unsigned16	2	S	x	x
TOTALIZER 2 UNIT (Mass p. cond.)	2	169	Simple	Unsigned16	2	S	x	x
TOTALIZER 1 UNIT (Volume std. cond.)	2	170	Simple	Unsigned16	2	S	x	x
TOTALIZER 2 UNIT (Vol. std. cond.)	2	171	Simple	Unsigned16	2	S	x	x
TOTALIZER 1 UNIT - (Vol. norm cond.)	2	172	Simple	Unsigned16	2	S	x	x
TOTALIZER 2 UNIT (Vol. norm cond.)	2	173	Simple	Unsigned16	2	S	x	x
MASS UNIT	2	174	Simple	Unsigned16	2	S	x	x
CUST.UNIT FACT.M	2	175	Simple	Float	4	S	x	x
CUSTOMER UNIT M	2	176	Simple	Visible String	8	S	x	x
HEIGHT UNIT	2	177	Simple	Unsigned16	2	S	x	x
CUST.UNIT FACT.H	2	178	Simple	Float	4	S	x	x
CUSTOMER UNIT H	2	179	Simple	Visible String	8	S	x	x
EMPTY PRESSURE	2	180	Simple	Float	4	N	x	
FULL PRESSURE	2	181	Simple	Float	4	N	x	
SIM. LEVEL	2	182	Simple	Float	4	D	x	x
SIM. TANK CONT.	2	183	Simple	Float	4	D	x	x
LEVEL MODE	2	184	Simple	Float	4	S	x	x
ACTIV LIN.TAB.X	2	185	Simple	Float	4	N	x	
X-VAL (semi-autom.):	2	186	Simple	Float	4	D	x	
TANK CONTENT MAX.	2	188	Simple	Float	4	S	x	x
TANK CONTENT MIN.	2	189	Simple	Float	4	S	x	x
HYDR. PRESS MAX.	2	190	Simple	Float	4	S	x	x
TAB. ACTIVATE	2	191	Simple	Unsigned8	1	D	x	
TABLE EDITOR	2	192	Simple	Unsigned8	1	N	x	x
ACTIVE LIN. TAB. Y	2	193	Simple	Float	4	N	x	x
HYDR. PRESS MIN.	2	194	Simple	Float	4	S	x	x
VALUE LIN. MIN.	2	195	Simple	Float	4	S	x	x
VALUE LIN. MAX	2	196	Simple	Float	4	S	x	x
TOTALIZER 1	2	197	Simple	Float	4	D	x	
TOTALIZER 2	2	198	Simple	Float	4	D	x	
LIN. MEASURAND	2	199	Simple	Unsigned8	1	S	x	x
LIND. MEASURAND	2	200	Simple	Unsigned8	1	S	x	x
COMB.MEASURAND.	2	201	Simple	Unsigned8	1	S	x	x
TABLE SELECTION	2	202	Simple	Unsigned8	1	S	x	x
TABLE EDITOR	2	203	Simple	Unsigned8	1	S	x	x
AREA UNIT	2	204	Simple	Unsigned16	2	S	x	x
SIM. PRESSURE	2	205	Simple	Float	4	D	x	x
PRESSURE ABS RNG	2	206	Simple	Float	4	Cst	x	
PRESSURE INVERT	2	207	Simple	Unsigned8	1	N	x	x
HEIGHT UNIT	2	240	Simple	Unsigned16	2	S	x	x
CALIBRATION MODE	2	241	Simple	Unsigned8	1	S	x	x
EMPTY HEIGHT	2	242	Simple	Float	4	S	x	x
FULL HEIGHT	2	243	Simple	Float	4	S	x	x
DENSITY UNIT	2	244	Simple	Unsigned16	2	S	x	x
ADJUST DENSITY	2	245	Simple	Float	4	S	x	x
PROCESS DENSITY	2	246	Simple	Float	4	S	x	x
MEAS.LEVEL EASY	2	247	Simple	Float	4	N	x	x
LEVEL SELECTION	2	248	Simple	Unsigned8	1	S	x	x
OUTPUT UNIT	2	249	Simple	Unsigned16	2	S	x	x

1) can only be reset

6.3.10 Data format

In the case of PROFIBUS PA, the cyclic transmission of analog values to the PLC is effected in data blocks 5 bytes long. The measured value is portrayed in the first 4 bytes in the form of floating point numbers in accordance with IEEE standard. The 5th byte contains standardized status information belonging to the device.

Byte 1	Byte 2	Byte 3	Byte 4	Byte 5
Measured value as IEEE 754 floating point number				Status

The measured value is transmitted as an IEEE 754 floating point number as follows:

$$\text{Measured value} = (-1)^{\text{Sign}} \times 2^{(E - 127)} \times (1 + F)$$

D15	D14	D13	D12	D11	D10	D9	D8	D7	D6	D5	D4	D3	D2	D1	D0	
Sign		Exponent (E)								Fraction (F)						
		2 ⁷	2 ⁶	2 ⁵	2 ⁴	2 ³	2 ²	2 ¹	2 ⁰	2 ⁻¹	2 ⁻²	2 ⁻³	2 ⁻⁴	2 ⁻⁵	2 ⁻⁶	2 ⁻⁷
Fraction (F)																
2 ⁻⁸	2 ⁻⁹	2 ⁻¹⁰	2 ⁻¹¹	2 ⁻¹²	2 ⁻¹³	2 ⁻¹⁴	2 ⁻¹⁵	2 ⁻¹⁶	2 ⁻¹⁷	2 ⁻¹⁸	2 ⁻¹⁹	2 ⁻²⁰	2 ⁻²¹	2 ⁻²²	2 ⁻²³	

Example

40 F0 00 00 hex = 0100 0000 1111 000 000 000 0000 binary

$$\begin{aligned} \text{Value} &= (-1)^0 \times 2^{(129 - 127)} \times (1 + 2^{-1} + 2^{-2} + 2^{-3}) \\ &= 1 \times 2^2 \times (1 + 0.5 + 0.25 + 0.125) \\ &= 1 \times 4 \times 1.875 \\ &= 7.5 \end{aligned}$$

- Not all programmable logic controllers support the IEEE 754-format. A conversion module must then be used or written.
- Depending on the type of data management (Most-Significant-Byte or Low-Significant-Byte) used in the PLC (master), it may also be necessary to change the byte sequence (byte-swapping routine).

Data strings

Some data types, e.g. DS-36, are listed in the slot/index table. These data types are data strings, structured according to PROFIBUS PA Specification Part 1, Version 3.x. They consist of several elements that are addressed by means of the slot, index and sub-index:

Parameter name	Type	Slot	Index	Element	Sub-index	Type	Size [byte]
OUT	DS-33	1	26	OUT VALUE	1	Float	4
				OUT STATUS	5	Unsigned8	1

Parameter name	Type	Slot	Index	Element	Sub-index	Type	Size [byte]
OUT SCALE	DS-36	1	28	EU_100_PERCENT	1	Float	4
				EU_0_PERCENT	5	Float	4
				UNITS_INDEX	9	Unsigned16	2
				DECIMAL POINT	11	Integer8	1

6.4 On-site operation – on-site display connected

If the on-site display is connected, the three operating keys are used to navigate through the operating menu, see → 27, "Function of operating elements – on-site display connected".

6.4.1 Menu structure

The menu is split into four levels. The three upper levels are used to navigate while you use the bottom level to enter numerical values, select options and save settings.

The structure of the OPERATING MENU depends on the measuring mode selected, e.g. if the "Pressure" measuring mode is selected, only the functions necessary for this mode are displayed.

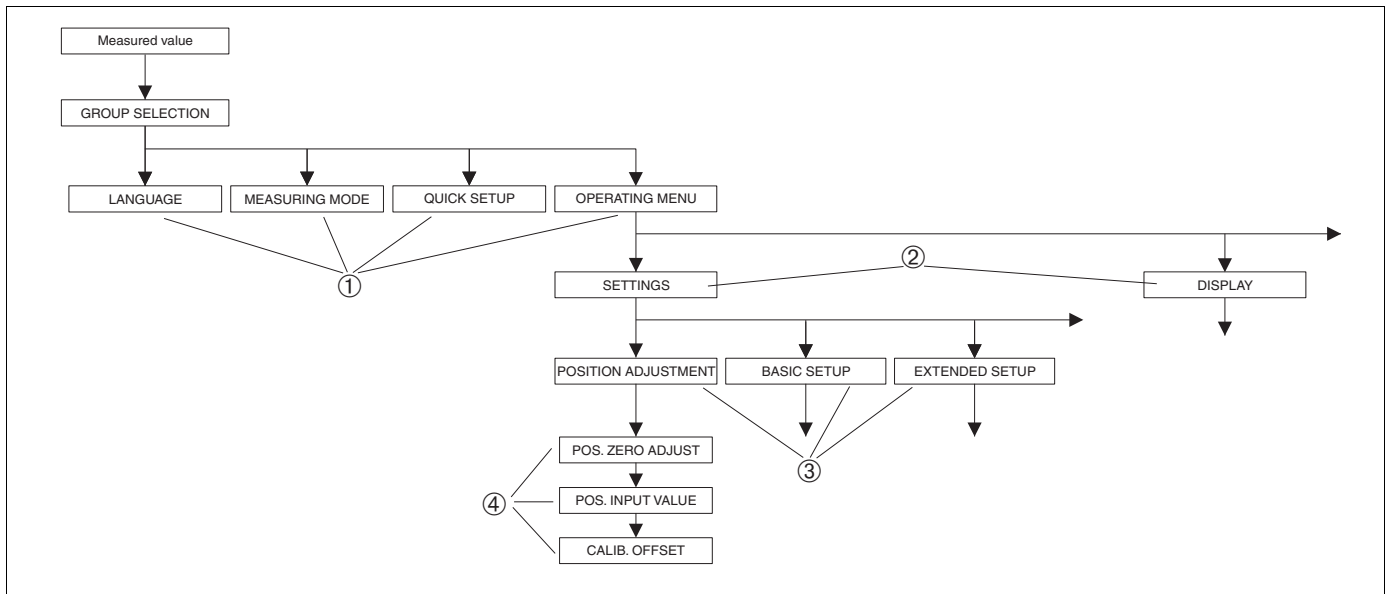

Fig. 17: Menu structure

- 1 1st selection level
- 2 2nd selection level
- 3 Function groups
- 4 Parameters

The LANGUAGE and MEASURING MODE parameters are only shown via the on-site display on the 1st selection level. In FieldCare, the LANGUAGE parameter is displayed in the DISPLAY group and the MEASURING MODE parameter is displayed in the QUICK SETUP menus or in the BASIC SETUP function group.

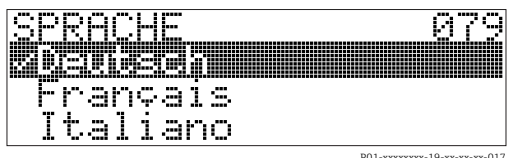
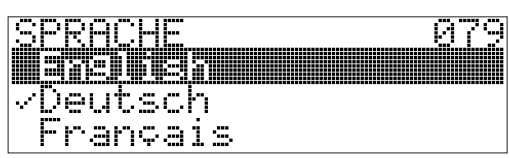
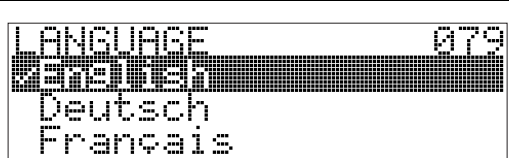

6.4.2 Selecting an option

Example: select "English" as the language of the menu.

On-site display	Operation
 <p>SPRACHE 079 Deutsch Français Italiano</p> <p><small>P01-xxxxxxxx-19-xx-xx-xx-017</small></p>	<p>"German" has been selected as the menu language. A ✓ in front of the menu text indicates the option that is currently active.</p>
 <p>SPRACHE 079 English ✓Deutsch Français</p> <p><small>P01-xxxxxxxx-19-xx-xx-xx-033</small></p>	<p>Select English with "+" or "-".</p>
 <p>LANGUAGE 079 English Deutsch Français</p> <p><small>P01-xxxxxxxx-19-xx-xx-xx-034</small></p>	<ol style="list-style-type: none"> 1. Confirm your choice with "E". A ✓ in front of the menu text indicates the option that is currently active. (English is now selected as the menu language.) 2. Jump to the next item with "E".

6.4.3 Taking pressure applied at device as value

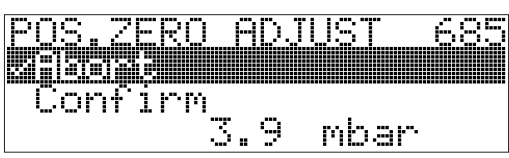
Example: performing position adjustment.

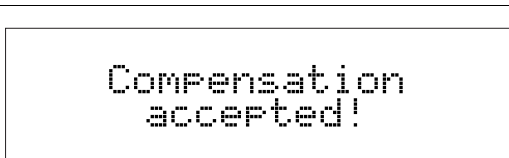
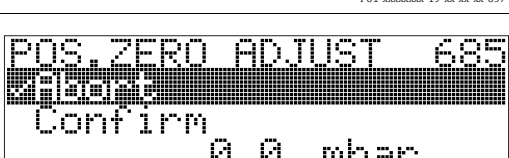
On-site display	Operation
 <p>POS.ZERO ADJUST 685 Confirm 3.9 mbar</p> <p><small>P01-xxxxxxxx-19-xx-xx-xx-158</small></p>	<p>The bottom line on the on-site display shows the pressure present, here 3.9 mbar.</p>
 <p>POS.ZERO ADJUST 685 Confirm ✓Abort 3.9 mbar</p> <p><small>P01-xxxxxxxx-19-xx-xx-xx-159</small></p>	<p>Use "+" or "-" to switch to the "Confirm" option. The active selection is highlighted in black.</p>
 <p>Compensation accepted!</p> <p><small>P01-xxxxxxxx-19-xx-xx-xx-037</small></p>	<p>Use "E" to assign the value (3.9 mbar) to the POS. ZERO ADJUST parameter. The device confirms the calibration and jumps back to the parameter, here POS. ZERO ADJUST (see next graphic).</p>
 <p>POS.ZERO ADJUST 685 Confirm Confirm 0.0 mbar</p> <p><small>P01-xxxxxxxx-19-xx-xx-xx-160</small></p>	<p>Switch to the next parameter with "E".</p>

6.4.4 Editing a value

Example: adjusting DAMPING VALUE function from 2.0 s to 30.0 s.

See also → 27, "Function of operating elements – on-site display connected".

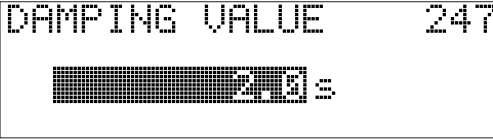
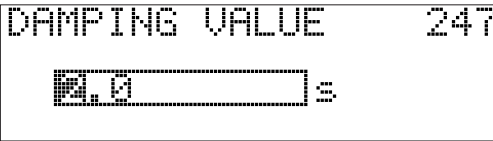
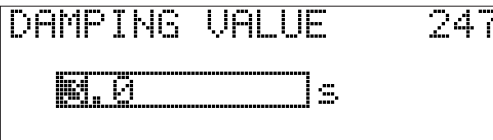
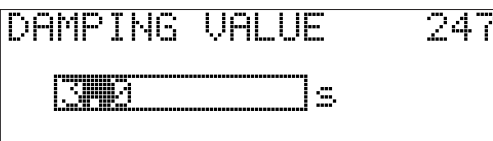
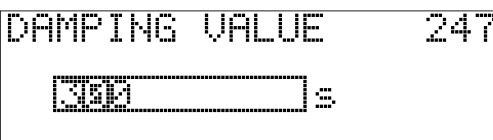
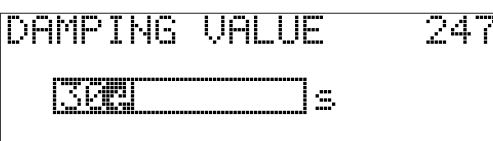
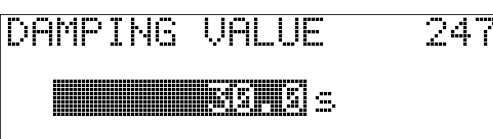
On-site display	Operation
 <p style="text-align: right; font-size: small;">P01-xxxxxxxx-19-xx-xx-xx-023</p>	<p>The on-site display shows the parameter to be changed. The value highlighted in black can be changed. The "s" unit is fixed and cannot be changed.</p>
 <p style="text-align: right; font-size: small;">P01-xxxxxxxx-19-xx-xx-xx-027</p>	<ol style="list-style-type: none"> 1. Press "+" or "-" to get to the editing mode. 2. The first digit is highlighted in black.
 <p style="text-align: right; font-size: small;">P01-xxxxxxxx-19-xx-xx-xx-028</p>	<ol style="list-style-type: none"> 1. Use "+" to change "2" to "3". 2. Confirm "3" with "E". The cursor jumps to the next position (highlighted in black).
 <p style="text-align: right; font-size: small;">P01-xxxxxxxx-19-xx-xx-xx-029</p>	<p>The decimal point is highlighted in black, i.e. you can now edit it.</p>
 <p style="text-align: right; font-size: small;">P01-xxxxxxxx-19-xx-xx-xx-030</p>	<ol style="list-style-type: none"> 1. Keep pressing "+" or "-" until "0" is displayed. 2. Confirm "0" with "E". The cursor jumps to the next position. "↓" is displayed and is highlighted in black. See next graphic.
 <p style="text-align: right; font-size: small;">P01-xxxxxxxx-19-xx-xx-xx-031</p>	<p>Use "E" to save the new value and exit the editing mode. See next graphic.</p>
 <p style="text-align: right; font-size: small;">P01-xxxxxxxx-19-xx-xx-xx-032</p>	<p>The new value for the damping is now 30.0 s.</p> <ul style="list-style-type: none"> - Jump to the next parameter with "E". - You can get back to the editing mode with "+" or "-".

6.5 Endress+Hauser operating program

The FieldCare operating program is an Endress+Hauser asset management tool based on FDT technology. Using FieldCare, you can configure all Endress+Hauser devices and devices from other manufacturers that support the FDT standard. You can find hardware and software requirements on the Internet: www.endress.com → Search: FieldCare → FieldCare → Technical data.

FieldCare supports the following functions:

- Configuration of transmitters in online operation
- Loading and saving of device data (upload/download)
- Tank linearization
- HistoROM[®]/M-DAT analysis
- Documenting the measuring point

Connection options:

- PROFIBUS PA via segment coupler and PROFIBUS interface card
- PROFIBUS PA via Fieldgate FXA720, segment coupler and PROFIBUS interface card
- Commubox FXA291 with ToF Adapter FXA291 via service interface
- In the "Level Standard" measuring mode, the configuration data that were loaded via FDT upload cannot be written again (FDT download). These data are only used to document the measuring point.
- Further information on FieldCare can be found on the Internet: <http://www.endress.com> → Downloads → Text search: FieldCare).

6.6 HistoROM[®]/M-DAT (optional)

NOTICE

Device could be destroyed!

Detach the HistoROM[®]/M-DAT module from the electronic insert or attach it to the insert in a de-energized state only.

HistoROM[®]/M-DAT is a memory module, which is attached to the electronic insert and fulfils the following functions:

- Back-up copy of configuration data
- Copying configuration data from one transmitter to another transmitter
- Cyclic recording of pressure and sensor temperature measured values
- Recording diverse events, such as alarms, configuration changes, underrange and overrange counters for pressure and temperature, exceeding and undershooting the user limits for pressure and temperature, etc.
- The HistoROM[®]/M-DAT can be retrofitted at any stage (order number: 52027785).
- The HistoROM data and the data in the device are analyzed once a HistoROM[®]/M-DAT module is attached to the electronic insert and power is re-established to the device. During the analysis, the messages "W702, HistoROM data not consistent" and "W706, Configuration in HistoROM and device not identical" can occur. For measures, see →  70, "Messages."

6.6.1 Copying configuration data

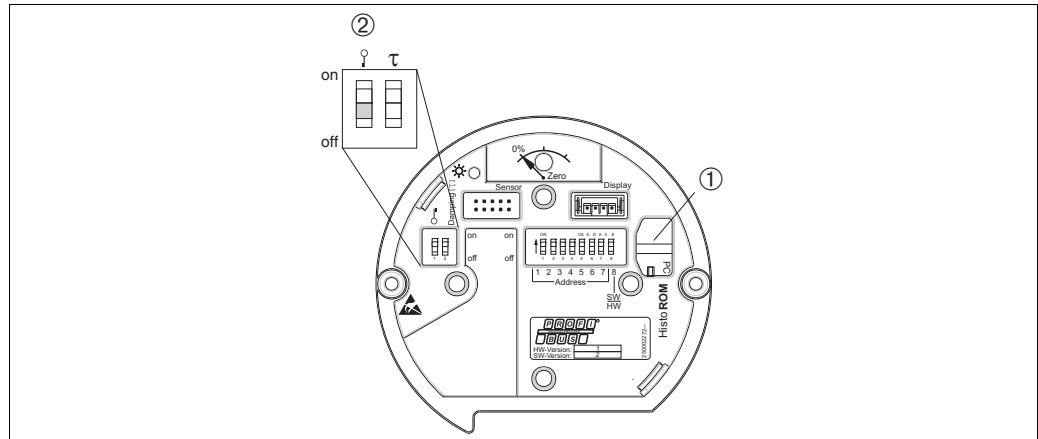

P01-xxxxxxx-19-xx-xx-xx-110

Electronic insert with optional HistoROM®/M-DAT memory module

- 1 Optional HistoROM®/M-DAT
- 2 To copy configuration data from the HistoROM®/M-DAT to a device or from a device to a HistoROM®/M-DAT, the operation must be unlocked (DIP switch 1, position "Off", parameter INSERT PIN No = 2457). See also → 53, "Locking/unlocking operation".

On-site operation via on-site display (optional) or remote operation

Copying configuration data from a device to a HistoROM®/M-DAT module:

Operation must be unlocked.

1. Disconnect the device from the supply voltage.
2. Attach the HistoROM®/M-DAT module to the electronic insert.
3. Re-establish the supply voltage to the device.
4. The DOWNLOAD SELECT. parameter (OPERATION menu) setting has no influence on an upload from the device into HistoROM.
5. Using the HistoROM CONTROL parameter, select the option "Device → HistoROM" as the data transfer direction.
6. Wait approx. 20 seconds. Configuration data are loaded from the device to the HistoROM®/M-DAT module. The device is not restarted.
7. Disconnect device from the supply voltage again.
8. Detach memory module.
9. Re-establish the supply voltage to the device.

Copying configuration data from a HistoROM®/M-DAT to a device:

Operation must be unlocked.

1. Disconnect the device from the supply voltage.
2. Attach the HistoROM®/M-DAT module to the electronic insert. Configuration data from another device are stored in the HistoROM®/M-DAT.
3. Re-establish the supply voltage to the device.
4. Use the DOWNLOAD SELECT parameter (OPERATION menu) to select which parameters are to be overwritten.

The following parameters are overwritten according to the selection:

– **Configuration copy (factory setting):**

all parameters except DEVICE SERIAL No., DEVICE DESIGN, TAG DESCRIPTOR, DESCRIPTION, IDENT NUMBER SEL, BUS ADDRESS and the parameters in the POSITION ADJUSTMENT, PROCESS CONNECTION, SENSOR TRIM and SENSOR DATA group.

– **Device replacement:**

all parameters except DEVICE SERIAL No., IDENT NUMBER SEL, DEVICE DESIGN, and the parameters in the POSITION ADJUSTMENT, PROCESS CONNECTION, SENSOR TRIM and SENSOR DATA group.

– **Electronics replacement:**

all parameters except the parameters in the SENSOR DATA group.

Factory setting: Configuration copy

5. Using the HistoROM CONTROL parameter (OPERATION menu), select the option "HistoROM → Device" as the data transfer direction.
6. Wait approx. 45 seconds. Configuration data are loaded from the HistoROM®/M-DAT to the device. The device is restarted.
7. Before removing the HistoROM®/M-DAT again from the electronic insert, disconnect the device from the supply voltage.

6.7 Locking/unlocking operation

Once you have entered all the parameters, you can lock your entries against unauthorized and undesired access.

You have the following possibilities for locking/unlocking operation:

- Via the DIP switch on the electronic insert, locally at the device.
- Via the on-site display (optional)
- Via communication, e.g. FieldCare

The  symbol on the on-site display indicates that operation is locked. Parameters which refer to how the display appears, e.g. LANGUAGE and DISPLAY CONTRAST can still be altered.



If operation is locked by means of the DIP switch, you can only unlock operation again by means of the DIP switch. If operation is locked by means of remote operation e.g. FieldCare, you can only unlock operation again by means of remote operation.

The table provides an overview of the locking functions:

Locking via	View/read parameters	Modify/write via ¹⁾		Unlocking via		
		On-site display	Remote operation	DIP switch	On-site display	Remote operation
DIP switch	Yes	No	No	Yes	No	No
On-site display	Yes	No	No	No	Yes	Yes
Remote operation	Yes	No	No	No	Yes	Yes

1) Parameters which refer to how the display appears, e.g. LANGUAGE and DISPLAY CONTRAST can still be altered.

6.7.1 Locking/unlocking operation locally via DIP switch

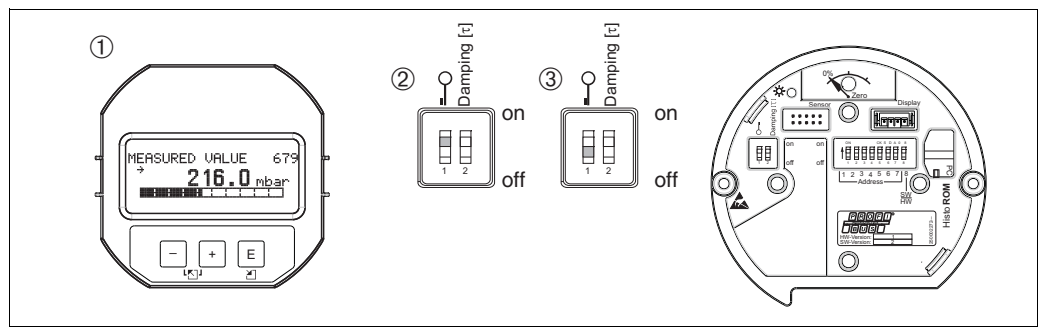

P01-xxxxxxx-19-xx-xx-xx-111

Fig. 18: DIP switch position "Hardware locking" on the electronic insert

- 1 If necessary, remove the (optional) on-site display
- 2 DIP switch is at "on": operation is locked.
- 3 DIP switch is at "off": operation is unlocked (operation possible)

6.7.2 Locking/unlocking operation via remote operation

	Description
Locking operation	<ol style="list-style-type: none"> 1. Select INSERT PIN No parameter, menu path on-site display: GROUP SELECTION ® OPERATING MENU ® OPERATING ® INSERT PIN No. Menu path in FieldCare: MANUFACTURER VIEW ® OPERATING MENU ® OPERATION ® INSERT PIN No. 2. To lock operation, enter "0" for the parameter.
Unlocking operation	<ol style="list-style-type: none"> 1. Select INSERT PIN No. parameter. 2. To unlock operation, enter "2457" for the parameter.

6.8 Factory setting (reset)

- Total reset: Press zero-key for at least 12 seconds. The LED on the electronic insert lights up briefly if a reset is being carried out.
- By entering a certain code, you can completely, or partially, reset the entries for the parameters to the factory settings. (For factory settings, refer to the Operating Instructions BA00296P "Cerabar S/Deltabar S/Deltapilot S, Description of device functions".) Enter the code by means of the ENTER RESET CODE parameter (OPERATION menu). There are various reset codes for the device. The following table illustrates which parameters are reset by the particular reset codes. Operation must be unlocked to reset parameters (see → 53, "Locking/unlocking operation").



- Any customer-specific configuration carried out at the factory is not affected by a reset (customer-specific configuration remains). If, after a reset, you wish the parameters to be reset to the factory settings, please contact Endress+Hauser Service.
- The OUT value may have to be rescaled after resetting with code 1, 40864 or 33333. See also → [67](#), "Scaling OUT value" and → [68](#), "System units (SET UNIT TO BUS)".

Reset code	Description and effect
1 or 40864	<p>Total reset</p> <ul style="list-style-type: none"> - This reset resets the following parameters: <ul style="list-style-type: none"> - POSITION ADJUSTMENT function group - BASIC SETUP function group - EXTENDED SETUP function group - LINEARIZATION function group (an existing linearization table is deleted) - TOTALIZER SETUP function group - OUTPUT group - PA DATA function group, SET UNIT TO BUS, 2ND CYCLIC VALUE, SEL.DISPLAY VALUE parameters - TRANSMITTER DATA function group, TAG DESCRIPTION, ADDITIONAL INFO parameters. - MESSAGES function group - All configurable messages ("Error" type) are set to "Warning". See also → 70, "Messages" and → 78, "Response of outputs to errors". - USER LIMITS function group - The bus address is not affected. - Any simulation running is terminated. - The device is restarted.
33333	<p>User reset</p> <ul style="list-style-type: none"> - This reset resets the following parameters: <ul style="list-style-type: none"> - POSITION ADJUSTMENT function group - BASIC SETUP function group, apart from customer-specific units - EXTENDED SETUP function group - TOTALIZER SETUP function group - OUTPUT group - PA DATA function group, SET UNIT TO BUS, 2ND CYCLIC VALUE, SEL.DISPLAY VALUE parameters - TRANSMITTER DATA function group, TAG DESCRIPTION, ADDITIONAL INFO parameters. - Any simulation running is terminated. - The device is restarted.
35710	<p>Measuring mode level reset</p> <ul style="list-style-type: none"> - Depending on the settings for the LEVEL MODE, LIN MEASURAND, LINd MEASURAND or COMB. MEASURAND parameters, the parameters needed for this measuring task will be reset. - Any simulation running is terminated. - The device is restarted. <p>Example LEVEL MODE = linear and LIN. MEASURAND = level</p> <ul style="list-style-type: none"> ■ HEIGHT UNIT = m ■ CALIBRATION MODE = wet ■ EMPTY CALIB. = 0 ■ FULL CALIB. = Sensor end value converted to mH₂O, e.g. 5.99 mH₂O for a 500 mbar (7.5 psi) sensor
34846	<p>Display reset</p> <ul style="list-style-type: none"> - This reset resets all parameters related to how the display appears (DISPLAY group). - Any simulation running is terminated. - The device is restarted.
41888	<p>HistoROM reset</p> <p>The measured value and event buffers are deleted. During the reset, the HistoROM has to be attached to the electronic insert.</p>

Reset code	Description and effect
2506	PowerUp reset (warm start) <ul style="list-style-type: none">- This reset resets all the parameters in the RAM. Data are read back anew from the EEPROM (processor is initialized again).- Any simulation running is terminated.- The device is restarted.
2712	Bus address reset <ul style="list-style-type: none">- The device address configured via the bus is reset to the 126 factory setting.- Any simulation running is terminated.- The device is restarted.

7 Commissioning

The device is configured for the "Pressure" measuring mode at the factory. The measuring range and the unit in which the measured value is transmitted, as well as the digital output value of the Analog Input Block OUT, correspond to the data on the nameplate. Following a reset with code 1, 40864 or 33333 the OUT Value may have to be rescaled (see also → [67](#), "Scaling OUT value" and → [68](#), "System units (SET UNIT TO BUS)").

▲ WARNING

The permitted process pressure is exceeded!

Risk of injury due to bursting of parts! Warning messages are generated if pressure is too high.

- ▶ If a pressure that is greater than the maximum permitted pressure is present at the device, messages "E115 Sensor overpressure" and "E727 Sensor pressure error - overrange" are output in succession. Only use the device within the sensor range limits!

NOTICE

The permitted process pressure is undershot!

Output of messages if pressure is too low.

- ▶ If a pressure that is lower than the minimum permitted pressure is present at the device, messages "E120 Sensor low pressure" and "E727 Sensor pressure error - overrange" are output in succession. Only use the device within the sensor range limits!

7.1 Configuring messages

- Messages E727, E115 and E120 are "Error" messages and can be configured as a "Warning" or an "Alarm". These messages are configured as "Warning" messages at the factory. This setting prevents the current output from assuming the set alarm current value for applications (e.g. cascade measurement) where the user is consciously aware of the fact that the sensor range can be exceeded.
- We recommend setting messages E727, E115 and E120 to "Alarm" in the following instances:
 - It is not necessary to go outside the sensor range for the measuring application.
 - A position adjustment must be carried out that has to correct a large measurement error as a result of the orientation of the device (e.g. devices with a diaphragm seal).

7.2 Installation and function check

Carry out a post-installation and a post-connection check as per the checklist before commissioning the device.

- Checklist for "post-installation check", → [20](#).
- Checklist for "post-connection check", → [23](#).

7.3 Commissioning via Class 2 master (FieldCare)

The procedure for commissioning and operating the FieldCare program is described in the integrated FieldCare online help.

Proceed as follows to commission the device:

1. Check the hardware write protection on the electronic insert (see → [§ 53](#), "Locking/unlocking operation").
The DIP STATUS parameter shows the status of the hardware write protection (menu path: MANUFACTURER VIEW → TRANSMITTER INFO → TRANSMITTER DATA)
2. Enter the tag name by means of the ADDITIONAL INFO parameter. (Menu path: MANUFACTURER VIEW → TRANSMITTER INFO → TRANSMITTER DATA or PROFILE VIEW → PB PARAMETER → DEVICE)
3. Assign the device an address in the bus (see also → [§ 31](#), "Device identification and addressing")
4. Configure manufacturer-specific device parameters via the MANUFACTURER VIEW menu.
5. Configure the PHYSICAL BLOCK (menu path: PROFILE VIEW → PHYSICAL BLOCK)
6. Configure the ANALOG INPUT BLOCK.
 - In the Analog Input Block, the input value or input range can be scaled in accordance with the requirements of the automation system (see → [§ 67](#), "Scaling OUT value") or perform SET.UNIT.TO.BUS (Kap. 7.9).
 - If necessary, configure the limit values.
7. Configure the cyclic data communication (see → [§ 33](#), "System integration" and → [§ 35](#), "Cyclic data exchange").

7.4 Selecting the language and measuring mode

7.4.1 On-site operation

The LANGUAGE and MEASURING MODE parameters are on the 1st selection level.
See also → [§ 48](#), "Menu structure".

The following languages are available:

- Deutsch
- English
- Français
- Italiano
- Español
- Nederlands
- Chinese (CHS)
- Japanese (JPN)

The following measuring modes are available:

- Pressure
- Level

7.4.2 FieldCare

The MEASURING MODE parameter is displayed in the QUICK SETUP menus in FieldCare and in the BASIC SETUP function group.

The following measuring modes are available:

- Pressure
- Level

The LANGUAGE parameter is arranged in the DISPLAY group.

- Use the LANGUAGE parameter to select the menu language for the on-site display.
- Select the menu language for FieldCare using the "Language Button" in the configuration window. Select the menu language for the FieldCare frame using the "Extra" menu → "Options" → "Display" → "Language".

The following languages are available:

- Deutsch
- English
- Français
- Italiano
- Español
- Nederlands
- Chinese (CHS)
- Japanese (JPN)

7.5 Position adjustment

Due to the orientation of the device, there may be a shift in the measured value, i.e. when the vessel is empty or partly filled, the measured value does not display zero. There are three ways to perform position adjustment.

- Menu path on-site display:
GROUP SELECTION → OPERATING MENU → SETTINGS → POSITION ADJUST.
- Menu path FieldCare:
MANUFACTURER VIEW → OPERATING MENU → SETTINGS → POSITION ADJUST.

Parameter name	Description
POS. ZERO ADJUST Entry	<p>Position adjustment – the pressure difference between zero (set point) and the measured pressure need not be known.</p> <p>Example:</p> <ul style="list-style-type: none"> – MEASURED VALUE = 2.2 mbar (0.032 psi) – Correct the MEASURED VALUE via the POS. ZERO ADJUST parameter using the "Confirm" option. This means that you are assigning the value 0.0 to the pressure present. – MEASURED VALUE (after pos. zero adjust) = 0.0 mbar <p>The CALIB. OFFSET parameter displays the resulting pressure difference (offset) by which the MEASURED VALUE was corrected.</p> <p>Factory setting: 0.0</p>
POS. INPUT VALUE Entry	<p>Position adjustment – the pressure difference between zero (set point) and the measured pressure need not be known. To correct the pressure difference, a reference measurement value (e.g. from a reference device) is required.</p> <p>Example:</p> <ul style="list-style-type: none"> – MEASURED VALUE = 0.5 mbar (0.0073 psi) – For the POS. INPUT VALUE parameter, specify the desired set point for the MEASURED VALUE, e.g. 2.0 mbar (0.029 psi). ($\text{MEASURED VALUE}_{\text{new}} = \text{POS. INPUT VALUE}$) – MEASURED VALUE (after entry for POS. INPUT VALUE) = 2.0 mbar (0.029 psi) – The CALIB. OFFSET parameter displays the resulting pressure difference (offset) by which the MEASURED VALUE was corrected. $\text{CALIB. OFFSET} = \text{MEASURED VALUE}_{\text{old}} - \text{POS. INPUT VALUE}$, here: $\text{CALIB. OFFSET} = 0.5 \text{ mbar (0.0073 psi)} - 2.0 \text{ mbar (0.029 psi)} = -1.5 \text{ mbar (0.022 psi)}$ <p>Factory setting: 0.0</p>
CALIB. OFFSET Entry	<p>Position adjustment - the pressure difference between zero (set point) and the measured pressure is known.</p> <p>Example:</p> <ul style="list-style-type: none"> – MEASURED VALUE = 2.2 mbar (0.032 psi) – Using the CALIB. OFFSET parameter, enter the value by which the MEASURED VALUE should be corrected. To correct the MEASURED VALUE to 0.0 mbar, you must enter the value 2.2 here. ($\text{MEASURED VALUE}_{\text{new}} = \text{MEASURED VALUE}_{\text{old}} - \text{CALIB. OFFSET}$) – MEASURED VALUE (after entry for calib. offset) = 0.0 mbar <p>Factory setting: 0.0</p>

7.6 Pressure measurement

7.6.1 Information regarding pressure measurement

- A Quick Setup menu is available for both the "Pressure" and "Level" measuring modes and guides you through the most important basic functions. You specify which Quick Setup menu should be displayed with the setting in the MEASURING MODE parameter. See also → 58, "Selecting the language and measuring mode".
- For a detailed description of the parameters see the Operating Instructions BA00296P "Cerabar S/Deltabar S/Deltapilot S, Description of device functions"
 - Table 6, POSITION ADJUSTMENT
 - Table 7, BASIC SETUP
 - Table 16, EXTENDED SETUP
- For differential pressure measurement, select the "Pressure" option by means of the MEASURING MODE parameter. The operating menu is then structured according to the measuring mode that is selected.

▲ WARNING

Changing the measuring mode affects the span (URV)!

This situation can result in product overflow.

- ▶ If the measuring mode is changed, the span setting (URV) must be verified in the operating menu "SETTINGS → BASIC SETUP" and reconfigured if necessary!

7.6.2 Quick Setup menu for the "Pressure" measuring mode

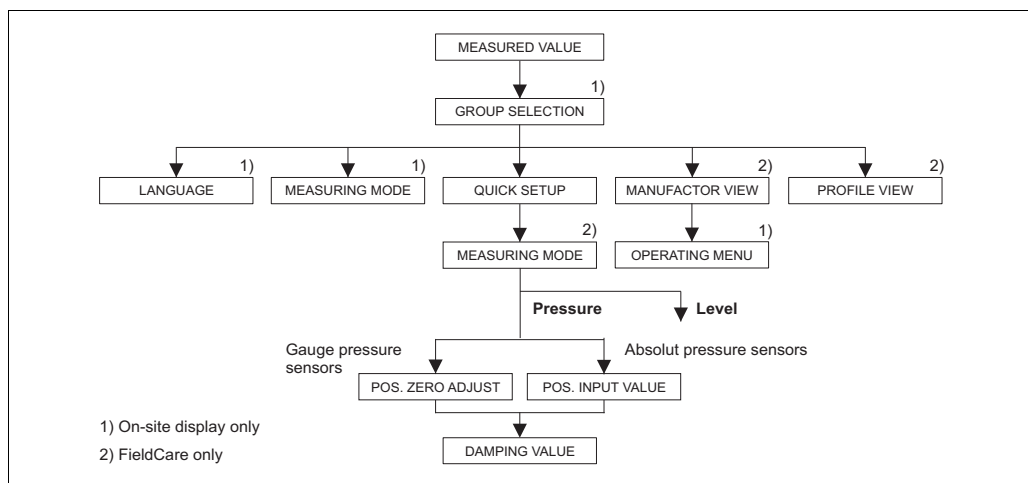



Fig. 19: Quick Setup menu for the "Pressure" measuring mode

On-site operation	FieldCare
<p>Measured value display Switch from the measured value display to GROUP SELECTION with F.</p>	<p>Measured value display Select the QUICK SETUP menu.</p>
<p>GROUP SELECTION Select the MEASURING MODE parameter.</p>	<p>MEASURING MODE Select "Pressure" option.</p>
<p>MEASURING MODE Select "Pressure" option.</p>	
<p>GROUP SELECTION Select the QUICK SETUP menu.</p>	

On-site operation	FieldCare
<p>POS. ZERO ADJUST Due to the orientation of the device, there may be a shift in the measured value. You correct the MEASURED VALUE via the POS. ZERO ADJUST parameter using the "Confirm" option, i.e. you assign the value 0.0 to the pressure present.</p>	<p>POS. ZERO ADJUST Due to the orientation of the device, there may be a shift in the measured value. You correct the MEASURED VALUE via the POS. ZERO ADJUST parameter using the "Confirm" option, i.e. you assign the value 0.0 to the pressure present.</p>
<p>POS. INPUT VALUE Due to the orientation of the device, there may be a shift in the measured value. Via the POS. INPUT VALUE parameter, specify the desired set point for the MEASURED VALUE.</p>	<p>POS. INPUT VALUE Due to the orientation of the device, there may be a shift in the measured value. Via the POS. INPUT VALUE parameter, specify the desired set point for the MEASURED VALUE.</p>
<p>DAMPING VALUE Enter damping time (time constant τ). The damping affects the speed at which all subsequent elements, such as the on-site display, measured value and OUT value of the Analog Input Block react to a change in the pressure.</p>	<p>DAMPING VALUE Enter damping time (time constant τ). The damping affects the speed at which all subsequent elements, such as the on-site display, measured value and OUT value of the Analog Input Block react to a change in the pressure.</p>

For on-site operation, see also

-  27, "Function of operating elements – on-site display connected" and
-  48, "On-site operation – on-site display connected".

7.7 Level measurement

7.7.1 Information on level measurement

- The Level and Pressure operating modes each have a quick setup menu which guides you through the most important basic functions. See →  65 for the "Level" quick setup menu.
- Furthermore, the three level modes "Level Easy Pressure", "Level Easy Height" and "Level Standard" are available to you for level measurement. You can select from the "Linear", "Pressure linearized" and "Height linearized" level types for the "Level Standard" level mode. The table in the "Overview of level measurement" section below provides an overview of the various measuring tasks.
 - In the "Level Easy Pressure" and "Level Easy Height" level modes, the values entered are not tested as extensively as in the "Level Standard" level mode. The values entered for EMPTY CALIB./FULL CALIB., EMPTY PRESSURE/FULL PRESSURE and EMPTY HEIGHT/FULL HEIGHT must have a minimum interval of 1% for the "Level Easy Pressure" and "Level Easy Height" level modes. The value will be rejected, and a message displayed, if the values are too close together. Other limit values are not checked, i.e. the values entered must be appropriate for the sensor and the measuring task for the measuring instrument to be able to measure correctly.
 - The "Level Easy Pressure" and "Level Easy Height" level modes encompass fewer parameters than the "Level Standard" mode and are used for quick and easy configuration of a level application.
 - Customer-specific units of fill level, volume and mass or a linearization table may only be entered in the "Level Standard" level mode.
- For a detailed parameter description and examples of parameters, see the Operating Instructions BA00296P "Cerabar S/Deltabar S/Deltapilot S, Description of device functions".

WARNING

Changing the measuring mode affects the span (URV)!

This situation can result in product overflow.

- ▶ If the measuring mode is changed, the span setting (URV) must be verified in the operating menu "SETTINGS → BASIC SETUP" and reconfigured if necessary!

7.7.2 Overview of level measurement

Measuring task	LEVEL SELECTION/ LEVEL MODE	Measured variable options	Description	Note	Measured value display
The measured variable is in direct proportion to the measured pressure. Calibration is performed by entering two pressure-level value pairs.	LEVEL SELECTION: Level Easy Pressure	Via OUTPUT UNIT parameter: %, level, volume or mass units.	<ul style="list-style-type: none"> - Calibration with reference pressure – wet calibration, see Operating Instructions BA00296P. - Calibration without reference pressure – dry calibration, see Operating Instructions BA00296P. 	<ul style="list-style-type: none"> - Incorrect entries are possible - Customized units are not possible 	The measured value display and the LEVEL BEFORE LIN parameter show the measured value.
The measured variable is in direct proportion to the measured pressure. Calibration is performed by entering the density and two height-level value pairs.	LEVEL SELECTION: Level Easy Height	Via OUTPUT UNIT parameter: %, level, volume or mass units.	<ul style="list-style-type: none"> - Calibration with reference pressure – wet calibration, see Operating Instructions BA00296P. - Calibration without reference pressure – dry calibration, see Operating Instructions BA00296P. 	<ul style="list-style-type: none"> - Incorrect entries are possible - Customized units are not possible 	The measured value display and the LEVEL BEFORE LIN parameter show the measured value.
The measured variable is in direct proportion to the measured pressure.	LEVEL SELECTION: Level standard/ LEVEL MODE: Linear	Via the LINEAR MEASURAND parameter: - % (level) - Level - Volume - Mass	<ul style="list-style-type: none"> - Calibration with reference pressure – wet calibration, see Operating Instructions BA00296P. - Calibration without reference pressure – dry calibration, see Operating Instructions BA00296P. 	<ul style="list-style-type: none"> - Incorrect entries are rejected by the device - Customized level, volume and mass units are possible 	The measured value display and the LEVEL BEFORE LIN parameter show the measured value.
The measured variable is not in direct proportion to the measured pressure as, for example, with containers with a conical outlet. A linearization table must be entered for the calibration.	LEVEL SELECTION: Level standard/ LEVEL MODE: Pressure linearized	Via LIND MEASURAND parameter: - Pressure + % - Pressure + volume - Pressure + mass	<ul style="list-style-type: none"> - Calibration with reference pressure: semi-automatic entry of linearization table, see Operating Instructions BA00296P. - Calibration without reference pressure: manual entry of linearization table, see Operating Instructions BA00296P. 	<ul style="list-style-type: none"> - Incorrect entries are rejected by the device - Customized level, volume and mass units are possible 	The measured value display and the TANK CONTENT parameter show the measured value.
<ul style="list-style-type: none"> - Two measured variables are required or - The container shape is given by value pairs, such as height and volume. <p>The 1st measured variable %-height or height must be in direct proportion to the measured pressure. The 2nd measured variable volume, mass or % must not be in direct proportion to the measured pressure. A linearization table must be entered for the 2nd measured variable. The 2nd measured variable is assigned to the 1st measured variable by means of this table.</p>	LEVEL SELECTION: Level standard/ LEVEL MODE: Height linearized	Via COMB. MEASURAND parameter: - Height + volume - Height + mass - Height + % - %-height + volume - %-height + mass - %-height + %	<ul style="list-style-type: none"> - Calibration with reference pressure: wet calibration and semi-automatic entry of linearization table, see Operating Instructions BA00296P. - Calibration without reference pressure: dry calibration and manual entry of linearization table, see Operating Instructions BA00296P. 	<ul style="list-style-type: none"> - Incorrect entries are rejected by the device - Customized level, volume and mass units are possible 	<p>The measured value display and the TANK CONTENT parameter display the 2nd measured value (volume, mass or %).</p> <p>The LEVEL BEFORE LIN parameter displays the 1st measured value (%-height or height).</p>

7.7.3 Quick Setup menu for the Level measuring mode

- Some parameters are only displayed if other parameters are appropriately configured. For example, the EMPTY CALIB. parameter is only displayed in the following cases:
 - LEVEL SELECTION "Level Easy Pressure" and CALIBRATION MODE "Wet"
 - LEVEL SELECTION "Level Standard", LEVEL MODE "Linear" and CALIBRATION MODE "Wet"
 You can find the LEVEL MODE and CALIBRATION MODE parameters in the BASIC SETUP function group.
- The following parameters are set to the following values in the factory:
 - LEVEL SELECTION: Level Easy Pressure
 - CALIBRATION MODE: Wet
 - OUTPUT UNIT or LIN. MEASURAND: %
 - EMPTY CALIB.: 0.0
 - FULL CALIB.: 100.0
- The quick setup is suitable for simple and quick commissioning. If you wish to make more complex settings, e.g. change the unit from "%" to "m", you will have to calibrate using the BASIC SETUP group. See Operating Instructions B00A296P.

⚠ WARNING

Changing the measuring mode affects the span (URV)!

This situation can result in product overflow.

- ▶ If the measuring mode is changed, the span setting (URV) must be verified in the operating menu "SETTINGS → BASIC SETUP" and reconfigured if necessary!

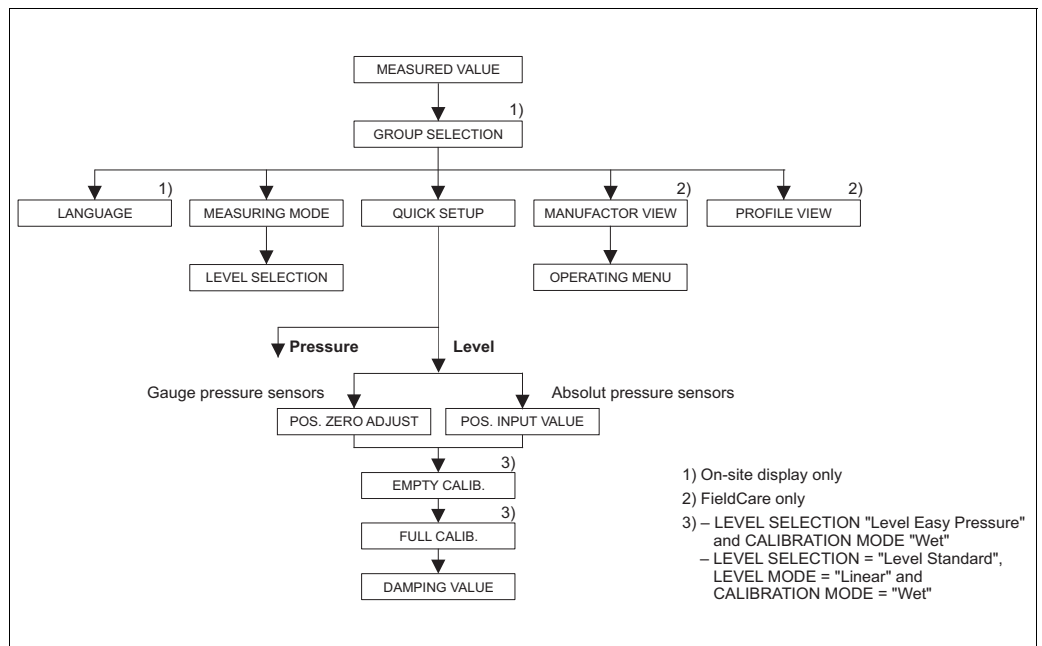



Fig. 20: Quick Setup menu for the "Level" measuring mode

On-site operation	FieldCare
Measured value display Switch from the measured value display to GROUP SELECTION with F.	Measured value display Select the QUICK SETUP menu.
GROUP SELECTION Select the MEASURING MODE.	MEASURING MODE Select "Level" option.
MEASURING MODE Select "Level" option.	
LEVEL SELECTION Select level mode. For an overview, see → 64.	LEVEL SELECTION Select level mode. For an overview, see → 64.

On-site operation	FieldCare
GROUP SELECTION Select the QUICK SETUP menu.	
POS. ZERO ADJUST Due to the orientation of the device, there may be a shift in the measured value. You correct the MEASURED VALUE via the POS. ZERO ADJUST parameter using the "Confirm" option, i.e. you assign the value 0.0 to the pressure present.	POS. ZERO ADJUST Due to the orientation of the device, there may be a shift in the measured value. You correct the MEASURED VALUE via the POS. ZERO ADJUST parameter using the "Confirm" option, i.e. you assign the value 0.0 to the pressure present.
POS. INPUT VALUE Due to the orientation of the device, there may be a shift in the measured value. Via the POS. INPUT VALUE parameter, specify the desired set point for the MEASURED VALUE.	POS. INPUT VALUE Due to the orientation of the device, there may be a shift in the measured value. For the POS. INPUT VALUE parameter, specify the desired set point for the MEASURED VALUE.
EMPTY CALIB. ¹⁾ Enter level value for the lower calibration point. For this parameter, enter a level value which is assigned to the pressure present at the device.	EMPTY CALIB. ¹⁾ Enter level value for the lower calibration point. For this parameter, enter a level value which is assigned to the pressure present at the device.
FULL CALIB. ¹⁾ Enter level value for the upper calibration point. For this parameter, enter a level value which is assigned to the pressure present at the device.	FULL CALIB. ¹⁾ Enter level value for the upper calibration point. For this parameter, enter a level value which is assigned to the pressure present at the device.
DAMPING VALUE Enter damping time (time constant τ). The damping affects the speed at which all subsequent elements, such as the on-site display, measured value and OUT value of the Analog Input Block react to a change in the pressure.	DAMPING VALUE Enter damping time (time constant τ). The damping affects the speed at which all subsequent elements, such as the on-site display, measured value and OUT value of the Analog Input Block react to a change in the pressure.

- 1) - LEVEL SELECTION "Level Easy Pressure" and CALIBRATION MODE "Wet"
 - LEVEL SELECTION "Level Standard", LEVEL MODE "Linear" and CALIBRATION MODE "Wet"

For on-site operation, see also

-  27, "Function of operating elements – on-site display connected" and
 →  48, "On-site operation – on-site display connected".

7.8 Scaling OUT value

In the Analog Input Block, the input value or input range can be scaled in accordance with the automation requirements.

Example:

The measuring range 0 to 500 mbar (0 to 7.5 psi) should be rescaled to 0 to 10000.

- Select PV SCALE group.

Menu path: PROFILE VIEW → ANALOG INPUT BLOCK → AI PARAMETER

- Enter "0" as the LOWER VALUE.

- Enter "500" as the UPPER VALUE.

- Select OUT SCALE group.

Menu path: PROFILE VIEW → ANALOG INPUT BLOCK → AI PARAMETER

- Enter "0" as the LOWER VALUE.

- Enter "10000" as the UPPER VALUE.

- For UNIT, select "User unit" for example.

The unit selected here does not have any effect on the scaling.

- Result:

At a pressure of 350 mbar (5.25 psi), the value 7000 is output to the PLC as the OUT value.

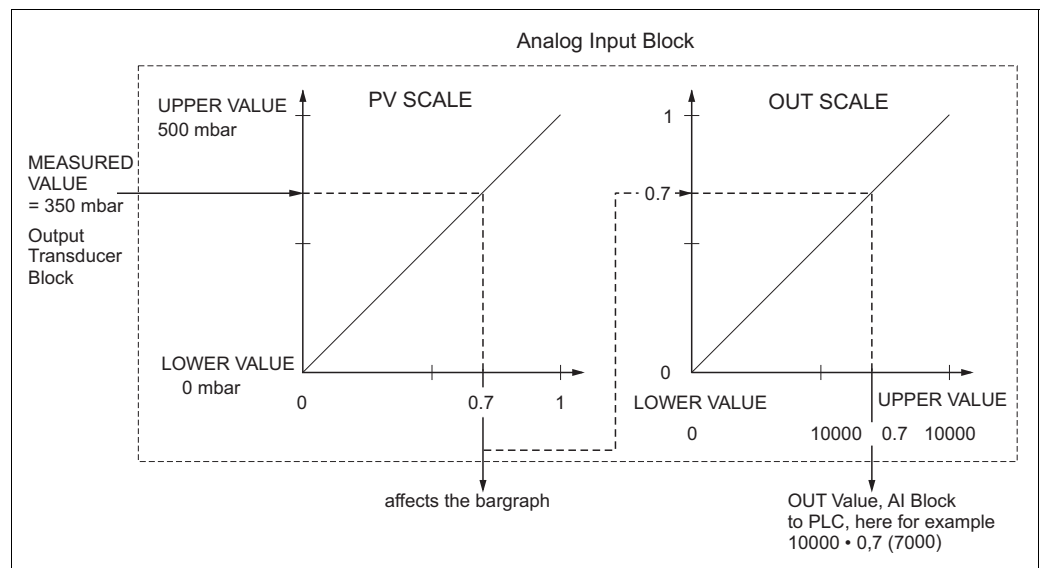

P01-xMx7xxxx-05-xx-xx-xx-002

- The OUT value can only be scaled via remote operation (e.g. FieldCare).
- When a unit changes within a measuring mode, the limits for PV SCALE are converted.
- When the measuring mode is changed, no conversion takes place. The device has to be recalibrated if the measuring mode is changed.
- Via the "SET.UNIT.TO.BUS" parameter (menu path: TRANSMITTER INFO → PA DATA) confirm with "Accept" to adapt the scaling of the Analog Input Block automatically to the Transducer Block. The OUT unit is updated accordingly (→ Kap. 7.9).

7.9 System units (SET UNIT TO BUS)

The Cerabar S on-site display and the MEASURED VALUE (FieldCare) show the same value as standard. The bar graph on the on-site display corresponds to the standardized value of the Analog Input Block. The digital output value of the OUT Analog Input Block works independently of the MEASURED VALUE or of the on-site display.

The following options are available so that the on-site display or the MEASURED VALUE and the digital output value show the same value:

- Set the values for the lower and upper limit of PV SCALE and OUT SCALE in the Analog Input Block as equal (see also →  67, "Scaling OUT value"):
 - LOWER VALUE (PV SCALE) = LOWER VALUE (OUT SCALE)
 - UPPER VALUE (PV SCALE) = UPPER VALUE (OUT SCALE)
- Confirm the option "Accept" by means of the SET UNIT TO BUS parameter. By confirming this, the limits for PV SCALE and OUT SCALE are automatically set as equal. The OUT unit assumes the value of the PV unit.

Example:

The on-site display or the MEASURED VALUE and the OUT value display 100 mbar (1.5 psi). Select the new unit "psi" by means of the PRESS. ENG. UNIT parameter.

- Display
 - On-site display and MEASURED VALUE: 1.45 psi (97 psi)
 - OUT value: 100 mbar (1.5 psi)
- Confirm the option "Accept" by means of the SET UNIT TO BUS parameter.
Menu path on-site display: GROUP SELECTION → OPERATING MENU → TRANSMITTER INFO → PA DATA
- Result:
The OUT value displays 1.45 psi (97 psi).

In the following instances, the on-site display or the MEASURED VALUE and the digital output value of the OUT Analog Input Block no longer display the same value:

- If you change the operating mode
- If you change the values for PV SCALE
- If you change the values for OUT SCALE
- If you change the unit of the primary value.

CAUTION

Note Dependencies when setting parameters!

- ▶ If you confirm the SET UNIT TO BUS parameter, please note that a change in the digital output value could affect the control system.

8 Maintenance

Keep the pressure compensation and GORE-TEX® filter (1) free from contamination and water.

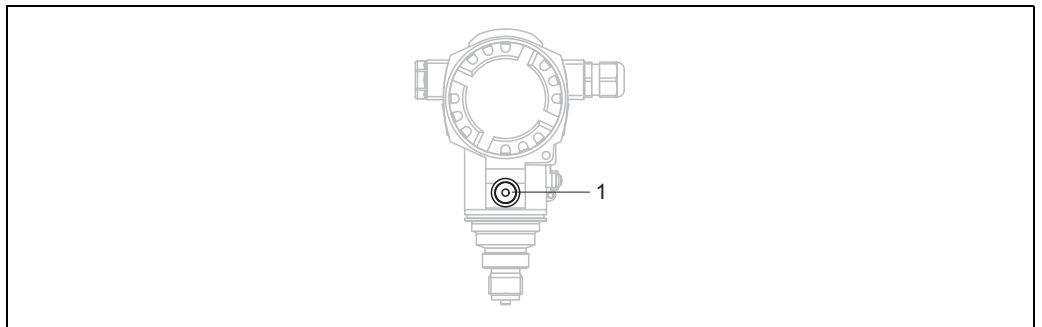

P01-PMC71xxx-17-xx-xx-xx-001

8.1 Cleaning instructions

Endress+Hauser provides flushing rings as an accessory to enable cleaning of the process membrane without removing the transmitter from the process.

For further information, please contact your local Endress+Hauser Sales Center.

8.1.1 PMP75

We recommend you perform CIP (cleaning in place (hot water)) before SIP (sterilization in place (steam)) for inline seals.

Frequent use of SIP cleaning increases the stress and strain on the process membrane. Under unfavorable conditions, frequent changes of temperature can lead to process membrane material fatigue and potentially leaks over the long term.

8.2 Exterior cleaning

Please note the following points when cleaning the measuring instrument:

- The cleaning agents used should not corrode the surface and the seals.
- Mechanical damage to the process membrane, e.g. due to pointed objects, must be avoided.
- Observe the degree of protection of the device. See the nameplate if necessary .

9 Troubleshooting

9.1 Messages

The following table lists all the possible messages that can occur.

The device differentiates between the error types "Alarm", "Warning" and "Error".

You may specify whether the device should react as if for an "Alarm" or "Warning" for "Error" messages. → See "Corresponds to NA 64" column and Section 8.2 "Response of outputs to errors".

In addition, the "Message category NE 107" column classifies the messages in accordance with NAMUR Recommendation NE 107:

- Failure (F)
- Function check (C)
- Out of specification (S)
- Maintenance required (M)

Error message display on the on-site display:

- The measured value display shows the message with the highest priority. → See "Priority" column.
- The ALARM STATUS parameter shows all the messages present in descending order of priority. You can scroll through all the messages present with the S key or O key.

Message display in FieldCare:

- The ALARM STATUS parameter shows the message with the highest priority. → See "Priority" column.

The device status (Device functions/Diagnostics menu) displays the status signal, the error message, cause and remedial measures.



- If the device detects a defect in the on-site display during initialization, special error messages are generated. → For the error messages, see Page 77, Section 8.1.1 "On-site display error messages".
- For support and further information, please contact Endress+Hauser Service.
- → See also Section 8.4, 8.5 and 8.6.
- The PROFIBUS status is updated depending on the message type, or depending on the setting for flexible alarms.

Code	Corresponds to NA 64	Message category NE 107	Message/description	Cause	Measure	Priority
101 (A101)	Alarm B	Failure (F)	F>Sensor electronic EEPROM error	<ul style="list-style-type: none"> - Electromagnetic effects are greater than specifications in the technical data. (→ See Section 9.) This message normally only appears briefly. - Sensor defect. 	<ul style="list-style-type: none"> - Wait a few minutes. - Restart the device. Perform reset (Code 2506 or 33062). - Block off electromagnetic effects or eliminate source of disturbance. - Replace sensor. 	17
102 (W102)	Warning C	Maintenance required (M)	M>Checksum error in EEPROM: peakhold segment	<ul style="list-style-type: none"> - Main electronics defect. Correct measurement can continue as long as you do not need the peak hold indicator function. 	<ul style="list-style-type: none"> - Replace main electronics. 	51
106 (W106)	Warning C	Function check (C)	C>Downloading - please wait	<ul style="list-style-type: none"> - Downloading. 	<ul style="list-style-type: none"> - Wait for download to complete. 	50

Code	Corresponds to NA 64	Message category NE 107	Message/description	Cause	Measure	Priority
110 (A110)	Alarm B	Failure (F)	F>Checksum error in EEPROM: configuration segment	<ul style="list-style-type: none"> - The supply voltage is disconnected when writing. - Electromagnetic effects are greater than specifications in the technical data. (→ See Section 9.) - Main electronics defect. 	<ul style="list-style-type: none"> - Reestablish supply voltage. If necessary, perform reset (Code 1 or 40864) and carry out calibration again. - Block off electromagnetic effects or eliminate sources of disturbance. - Replace main electronics. 	6
113 (A113)	Alarm B	Failure (F)	F>ROM failure in transmitter electronics.	<ul style="list-style-type: none"> - Main electronics defect. 	<ul style="list-style-type: none"> - Replace main electronics. 	1
115 (E115)	Error B Factory setting: Warning	Out of specification (S)	S>Sensor overpressure	<ul style="list-style-type: none"> - Overpressure present. - Sensor defect. 	<ul style="list-style-type: none"> - Reduce pressure until message disappears. - Replace sensor. 	29
116 (W116)	Warning C	Maintenance required (M)	M>Download error, repeat download	<ul style="list-style-type: none"> - The file is corrupt. - During the download, the data are not correctly transmitted to the processor, e.g. due to open cable connections, spikes (ripple) on the supply voltage or electromagnetic effects. 	<ul style="list-style-type: none"> - Use another file. - Check cable connection PC – transmitter. - Block off electromagnetic effects or eliminate sources of disturbance. - Perform reset (Code 1 or 40864) and carry out calibration again. - Repeat download. 	36
120 (E120)	Error B Factory setting: Warning	Out of specification (S)	S>Sensor low pressure	<ul style="list-style-type: none"> - Pressure too low. - Sensor defect. 	<ul style="list-style-type: none"> - Increase pressure until message disappears. - Replace sensor. 	30
121 (A121)	Alarm B	Failure (F)	F>Checksum error in factory segment of EEPROM	<ul style="list-style-type: none"> - Main electronics defect. 	<ul style="list-style-type: none"> - Replace main electronics. 	5
122 (A122)	Alarm B	Failure (F)	F>Sensor not connected	<ul style="list-style-type: none"> - Cable connection sensor –main electronics disconnected. - Electromagnetic effects are greater than specifications in the technical data. (→ See Section 9.) - Main electronics defect. - Sensor defect. 	<ul style="list-style-type: none"> - Check cable connection and repair if necessary. - Block off electromagnetic effects or eliminate source of disturbance. - Replace main electronics. - Replace sensor. 	13
130 (A130)	Alarm B	Failure (F)	F>EEPROM is defect.	<ul style="list-style-type: none"> - Main electronics defect. 	<ul style="list-style-type: none"> - Replace main electronics. 	10
131 (A131)	Alarm B	Failure (F)	F>Checksum error in EEPROM: min/max segment	<ul style="list-style-type: none"> - Main electronics defect. 	<ul style="list-style-type: none"> - Replace main electronics. 	9
132 (A132)	Alarm B	Failure (F)	F>Checksum error in totalizer EEPROM	<ul style="list-style-type: none"> - Main electronics defect. 	<ul style="list-style-type: none"> - Replace main electronics. 	7
133 (A133)	Alarm B	Failure (F)	F>Checksum error in History EEPROM	<ul style="list-style-type: none"> - An error occurred when writing. - Main electronics defect. 	<ul style="list-style-type: none"> - Perform reset (Code 1 or 40864) and carry out calibration again. - Replace main electronics. 	8
602 (W602)	Warning C	Function check (C)	C>Linearization curve not monotone	<ul style="list-style-type: none"> - The linearization table is not increasing or decreasing monotonically. 	<ul style="list-style-type: none"> - Add to or correct linearization table. Then accept linearization table again. 	55

Code	Corresponds to NA 64	Message category NE 107	Message/description	Cause	Measure	Priority
604 (W604)	Warning C	Function check (C)	C>Linearization table not valid. Less than 2 points or points too close	Note! From software version "03.10.xx" onwards, there is no min. span for the Y-points.	<ul style="list-style-type: none"> - Add to linearization table. Accept linearization table again if necessary. - Correct linearization table and accept again. 	58
				<ul style="list-style-type: none"> - The linearization table consists of less than 2 points. - At least 2 points in the linearization table are too close together. A minimum gap of 0.5 % of the distance between two points must be maintained. Spans for the "Pressure linearized" option: HYDR. PRESS MAX. - HYDR. PRESS MIN.; TANK CONTENT MAX. - TANK CONTENT MIN. Spans for the "Height linearized" option: LEVEL MAX - LEVEL MIN; TANK CONTENT MAX. - TANK CONTENT MIN. 		
613 (W613)	Warning I	Function check (C)	C>Simulation is active	<ul style="list-style-type: none"> - Simulation is switched on, i.e. the device is not measuring at present. 	<ul style="list-style-type: none"> - Deactivate simulation. 	58
616 (W616)	Warning I	Function check (C)	C>Simulation is active (AI)	<ul style="list-style-type: none"> - Simulation of the AI Block is switched on, i.e. the Main Process Value (AI OUT VALUE) that is output does not correspond to the sensor signal. 	<ul style="list-style-type: none"> - Switch off simulation of the AI Block (ANALOG INPUT BLOCK → Set the AI STANDARD PARAMETER → TARGET MODE to Automatic and set AI PARAMETER/SIMULATE to No). 	58
700 (W700)	Warning C	Maintenance required (M)	M>Last configuration not stored	<ul style="list-style-type: none"> - An error occurred when writing or reading configuration data or the power supply was disconnected. - Main electronics defect. 	<ul style="list-style-type: none"> - Perform reset (Code 1 or 40864) and carry out calibration again. - Replace main electronics. 	52
702 (W702)	Warning C	Maintenance required (M)	M>HistoROM data not consistent	<ul style="list-style-type: none"> - Data were not written correctly to the HistoROM, e.g. if the HistoROM was detached during the writing process. - HistoROM does not have any data. 	<ul style="list-style-type: none"> - Repeat upload. - Perform reset (Code 1 or 40864) and carry out calibration again. - Copy suitable data to the HistoROM. (→ See also Page 52, Section 5.6.1 "Copying configuration data".) 	53
703 (A703)	Alarm B	Failure (F)	F>Measurement error	<ul style="list-style-type: none"> - Fault in the main electronics. - Main electronics defect. 	<ul style="list-style-type: none"> - Briefly disconnect device from the power supply. - Replace main electronics. 	22
704 (A704)	Alarm B	Function check (C)	C>Measurement error	<ul style="list-style-type: none"> - Fault in the main electronics. - Main electronics defect. 	<ul style="list-style-type: none"> - Briefly disconnect device from the power supply. - Replace main electronics. 	12
705 (A705)	Alarm B	Failure (F)	F>Measurement error	<ul style="list-style-type: none"> - Fault in the main electronics. - Main electronics defect. 	<ul style="list-style-type: none"> - Briefly disconnect device from the power supply. - Replace main electronics. 	21

Code	Corresponds to NA 64	Message category NE 107	Message/description	Cause	Measure	Priority
706 (W706)	Warning C	Maintenance required (M)	M>Configuration in HistoROM and device not identical.	<ul style="list-style-type: none"> Configuration (parameters) in the HistoROM and in the device not identical. 	<ul style="list-style-type: none"> Copy data from the device to the HistoROM. (→ See also Page 52, Section 5.6.1 "Copying configuration data".) Copy data from the HistoROM to the device. (→ See also Page 52, Section 5.6.1 "Copying configuration data".) The message remains if the HistoROM and the device have different software versions. The message goes out if you copy the data from the device to the HistoROM. Device reset codes such as 1 or 40864 do not have any effect on the HistoROM. That means that if you do a reset, the configurations in the HistoROM and in the device may not be the same. 	57
707 (A707)	Alarm B	Function check (C)	C>X-VAL. of lin. table out of edit limits	<ul style="list-style-type: none"> At least one X-VALUE in the linearization table is either below the value for HYDR. PRESS. MIN. or LEVEL MIN or above the value for HYDR. PRESS. MAX. or LEVEL MAX. 	<ul style="list-style-type: none"> Carry out calibration again. (→ See also Operating Instructions BA00296P or these Operating Instructions, Page 2.) 	37
710 (W710)	Warning C	Function check (C)	B>Set span too small. Not allowed	<ul style="list-style-type: none"> Values for calibration (e.g. lower range value and upper range value) are too close together. The sensor was replaced and the customer-specific configuration does not suit the sensor. Unsuitable download carried out. 	<ul style="list-style-type: none"> Adjust calibration to suit sensor. (→ See also Operating Instructions BA00296P, parameter description MINIMUM SPAN or these Operating Instructions, Page 2.) Adjust calibration to suit sensor. Replace sensor with a suitable sensor. Check configuration and perform download again. 	49
713 (A713)	Alarm B	Function check (C)	C>100% POINT level out of edit limits	<ul style="list-style-type: none"> The sensor was replaced. 	<ul style="list-style-type: none"> Carry out calibration again. 	38
715 (E715)	Error C Factory setting: Warning	Out of specification (S)	S>Sensor over temperature	<ul style="list-style-type: none"> The temperature measured in the sensor is higher than the upper nominal temperature of the sensor. (→ See also Operating Instructions BA00296P, parameter description Tmax SENSOR or these Operating Instructions, Page 2.) Unsuitable download carried out. 	<ul style="list-style-type: none"> Reduce process temperature/ ambient temperature. Check configuration and perform download again. 	32
716 (E716)	Error B Factory setting: Alarm	Failure (F)	F>Sensor membrane broken	<ul style="list-style-type: none"> Sensor defect. 	<ul style="list-style-type: none"> Replace sensor. Reduce the pressure. 	24

Code	Corresponds to NA 64	Message category NE 107	Message/description	Cause	Measure	Priority
717 (E717)	Error C Factory setting: Warning	Out of specification (S)	S>Transmitter over temperature	<ul style="list-style-type: none"> - The temperature measured in the electronics is greater than the upper nominal temperature of the electronics (+88 °C +190 °F). - Unsuitable download carried out. 	<ul style="list-style-type: none"> - Reduce ambient temperature. - Check configuration and perform download again. 	34
718 (E718)	Error C Factory setting: Warning	Out of specification (S)	S>Transmitter under temperature	<ul style="list-style-type: none"> - The temperature measured in the electronics is smaller than the lower nominal temperature of the electronics (-43 °C -45 °F). - Unsuitable download carried out. 	<ul style="list-style-type: none"> - Increase ambient temperature. Insulate device if necessary. - Check configuration and perform download again. 	35
719 (A719)	Alarm B	Function check (C)	C>Y-VAL of lin. table out of edit limits	<ul style="list-style-type: none"> - At least one Y-VALUE in the linearization table is below the MIN. TANK CONTENT or above the MAX. TANK CONTENT. 	<ul style="list-style-type: none"> - Carry out calibration again. (→ See also Operating Instructions BA00296P, chapter 5 or these Operating Instructions, Page 2.) 	39
720 (E720)	Error C Factory setting: Warning	Out of specification (S)	S>Sensor under temperature	<ul style="list-style-type: none"> - The temperature measured in the sensor is less than the lower nominal temperature of the sensor. (→ See also Operating Instructions BA00296P, parameter description Tmin SENSOR or Operating Instructions, Page 2.) - Unsuitable download carried out. - Loose connection at sensor cable 	<ul style="list-style-type: none"> - Increase process temperature/ambient temperature. - Check configuration and perform download again. - Wait a short period of time and tighten the connection, or avoid loose connection. 	33
721 (A721)	Alarm B	Function check (C)	C>ZERO POSITION level out of edit limits	<ul style="list-style-type: none"> - LEVEL MIN or LEVEL MAX has been changed. 	<ul style="list-style-type: none"> - Perform reset (Code 35710) and carry out calibration again. 	40
722 (A722)	Alarm B	Function check (C)	C>EMPTY CALIB. or FULL CALIB. out of edit limits	<ul style="list-style-type: none"> - LEVEL MIN or LEVEL MAX has been changed. 	<ul style="list-style-type: none"> - Perform reset (Code 35710) and carry out calibration again. 	41
725 (A725)	Alarm B	Failure (F)	F>Sensor connection error, cycle disturbance	<ul style="list-style-type: none"> - Electromagnetic effects are greater than specifications in the technical data. (→ See Kap. 10.) - Setscrew loose. - Sensor or main electronics defect. 	<ul style="list-style-type: none"> - Block off electromagnetic effects or eliminate source of disturbance. - Retighten setscrew with 1 Nm (0.74 lbf ft) (see Kap. 4.4.8). - Replace sensor or main electronics. 	25
726 (E726)	Error C Factory setting: Warning	Out of specification (S)	S>Sensor temperature error - overrange	<ul style="list-style-type: none"> - Electromagnetic effects are greater than specifications in the technical data. (→ See Section 9.) - Process temperature is outside permitted range. - Sensor defect. 	<ul style="list-style-type: none"> - Block off electromagnetic effects or eliminate source of disturbance. - Check temperature present, reduce or increase if necessary. - If the process temperature is within the permitted range, replace sensor. 	31

Code	Corresponds to NA 64	Message category NE 107	Message/description	Cause	Measure	Priority
727 (E727)	Error C Factory setting: Warning	Out of specification (S)	S>Sensor pressure error - overrange	<ul style="list-style-type: none"> - Electromagnetic effects are greater than specifications in the technical data. (→ See Section 9.) - Pressure is outside permitted range. - Sensor defect. 	<ul style="list-style-type: none"> - Block off electromagnetic effects or eliminate source of disturbance. - Check pressure present, reduce or increase if necessary. - If the pressure is within the permitted range, replace sensor. 	28
728 (A728)	Alarm B	Failure (F)	F>RAM error	<ul style="list-style-type: none"> - Fault in the main electronics. - Main electronics defect. 	<ul style="list-style-type: none"> - Briefly disconnect device from the power supply. - Replace main electronics. 	2
729 (A729)	Alarm B	Failure (F)	F>RAM error	<ul style="list-style-type: none"> - Fault in the main electronics. - Main electronics defect. 	<ul style="list-style-type: none"> - Briefly disconnect device from the power supply. - Replace main electronics. 	3
730 (E730)	Error C Factory setting: Warning	Out of specification (S)	S>LRV user limits exceeded	<ul style="list-style-type: none"> - Pressure measured value has undershot the value specified for the Pmin ALARM WINDOW parameter. - Loose connection at sensor cable 	<ul style="list-style-type: none"> - Check system/pressure measured value. - Change value for Pmin ALARM WINDOW if necessary. (→ See also Operating Instructions BA00296P, parameter description Pmin ALARM WINDOW or these Operating Instructions, Page 2.) - Wait a short period of time and tighten the connection, or avoid loose connection. 	46
731 (E731)	Error C Factory setting: Warning	Out of specification (S)	S>URV user limits exceeded	<ul style="list-style-type: none"> - Pressure measured value has overshoot the value specified for the Pmax ALARM WINDOW parameter. 	<ul style="list-style-type: none"> - Check system/pressure measured value. - Change value for Pmax ALARM WINDOW if necessary. (→ See also Operating Instructions BA00296P, parameter description Pmax ALARM WINDOW or these Operating Instructions, Page 2.) 	45
732 (E732)	Error C Factory setting: Warning	Out of specification (S)	S>LRV Temp. User limits exceeded	<ul style="list-style-type: none"> - Temperature measured value has undershot the value specified for the Tmin ALARM WINDOW parameter. - Loose connection at sensor cable 	<ul style="list-style-type: none"> - Check system/temperature measured value. - Change value for Tmin ALARM WINDOW if necessary. (→ See also Operating Instructions BA00296P, parameter description Tmin ALARM WINDOW or these Operating Instructions, Page 2.) - Wait a short period of time and tighten the connection, or avoid loose connection. 	48

Code	Corresponds to NA 64	Message category NE 107	Message/description	Cause	Measure	Priority
733 (E733)	Error C Factory setting: Warning	Out of specification (S)	S>URV Temp. User limits exceeded	<ul style="list-style-type: none"> Temperature measured value has overshoot the value specified for the Tmax ALARM WINDOW parameter. 	<ul style="list-style-type: none"> Check system/temperature measured value. Change value for Tmax ALARM WINDOW if necessary. (→ See also Operating Instructions BA00296P, parameter description Tmax ALARM WINDOW or these Operating Instructions, Page 2.) 	47
736 (A736)	Alarm B	Failure (F)	F>RAM error	<ul style="list-style-type: none"> Fault in the main electronics. Main electronics defect. 	<ul style="list-style-type: none"> Briefly disconnect device from the power supply. Replace main electronics. 	4
737 (A737)	Alarm B	Failure (F)	F>Measurement error	<ul style="list-style-type: none"> Fault in the main electronics. Main electronics defect. 	<ul style="list-style-type: none"> Briefly disconnect device from the power supply. Replace main electronics. 	20
738 (A738)	Alarm B	Failure (F)	F>Measurement error	<ul style="list-style-type: none"> Fault in the main electronics. Main electronics defect. 	<ul style="list-style-type: none"> Briefly disconnect device from the power supply. Replace main electronics. 	19
739 (A739)	Alarm B	Failure (F)	F>Measurement error	<ul style="list-style-type: none"> Fault in the main electronics. Main electronics defect. 	<ul style="list-style-type: none"> Briefly disconnect device from the power supply. Replace main electronics. 	23
740 (E740)	Error C Factory setting: Warning	Maintenance required (M)	M>Calculation overflow, bad configuration, hardware defect	<ul style="list-style-type: none"> Level measuring mode: Level mode* "LIND. MEASURAND.": The measured pressure has undershot the value for HYDR. PRESS. MIN. or overshoot the value for HYDR. PRESS. MAX. (*For other level modes: The measured level did not reach the LEVEL MIN value or exceeded the LEVEL MAX value.) Pressure measuring mode: Main electronics defect. 	<ul style="list-style-type: none"> Check configuration and carry out calibration again if necessary. Select a device with a suitable measuring range. See also Operating Instructions BA296P, parameter description LEVEL MIN or these Operating Instructions, Page 2. Replace main electronics. 	27
741 (A741)	Alarm B	Function check (C)	C>TANK HEIGHT out of edit limits	<ul style="list-style-type: none"> LEVEL MIN or LEVEL MAX has been changed. 	<ul style="list-style-type: none"> Perform reset (Code 35710) and carry out calibration again. 	43
742 (A742)	Alarm B	Failure (F)	F>Sensor connection error (upload)	<ul style="list-style-type: none"> Electromagnetic effects are greater than specifications in the technical data. (→ See Section 9.) This message normally only appears briefly. Cable connection between sensor and main electronics disconnected. Sensor defect. 	<ul style="list-style-type: none"> Wait a few minutes. Perform reset (Code 35710) and carry out calibration again. Check cable connection and repair if necessary. Replace sensor. 	18
743 (A743)	Alarm B	Failure (F)	F>Electronic PCB error during initialization	<ul style="list-style-type: none"> Electromagnetic effects are greater than specifications in the technical data. (→ See Section 9.) This message normally only appears briefly. Main electronics defect. 	<ul style="list-style-type: none"> Wait a few minutes. Restart the device. Perform reset (Code 2506 or 33062). Replace main electronics. 	14

Code	Corresponds to NA 64	Message category NE 107	Message/description	Cause	Measure	Priority
744 (A744)	Alarm B	Failure (F)	F>Main electronic PCB error	<ul style="list-style-type: none"> Electromagnetic effects are greater than specifications in the technical data. (→ See Section 9.) Main electronics defect. 	<ul style="list-style-type: none"> Restart the device. Perform reset (Code 2506 or 33062). Block off electromagnetic effects or eliminate source of disturbance. Replace main electronics. 	11
745 (W745)	Warning C	Maintenance required (M)	M>Sensor data unknown	<ul style="list-style-type: none"> Sensor does not suit the device (electronic sensor nameplate). Device continues measuring. 	<ul style="list-style-type: none"> Replace sensor with a suitable sensor. 	54
746 (W746)	Warning C	Function check (C)	C>Sensor connection error - initializing	<ul style="list-style-type: none"> Electromagnetic effects are greater than specifications in the technical data. (→ See Section 9.) This message normally only appears briefly. Overpressure or low pressure present. 	<ul style="list-style-type: none"> Wait a few minutes. Restart the device. Perform reset (Code 1 or 40864). Block off electromagnetic effects or eliminate source of disturbance. Reduce or increase pressure. 	26
747 (A747)	Alarm B	Failure (F)	F>Sensor software not compatible to electronics	<ul style="list-style-type: none"> Sensor does not suit the device (electronic sensor nameplate). 	<ul style="list-style-type: none"> Replace sensor with a suitable sensor. 	16
748 (A748)	Alarm B	Failure (F)	F>Memory failure in signal processor	<ul style="list-style-type: none"> Electromagnetic effects are greater than specifications in the technical data. (→ See Section 9.) Main electronics defect. 	<ul style="list-style-type: none"> Block off electromagnetic effects or eliminate source of disturbance. Replace main electronics. 	15
750 (A750)	Warning C	Function check (C)	C>Configuration not permitted	<ul style="list-style-type: none"> By means of the operation profile, options were selected for the configuration of the device but the options do not suit one another. For example, if the option "1" (linearization table) was selected for LIN_TYPE and the unit "1347 (m³/s)" was selected for PRIMARY_VALUE_UNIT. 	<ul style="list-style-type: none"> Check configuration. Perform reset (Code 1 or 40864) and recalibrate the device. 	44



9.1.1 On-site display error messages

If the device detects a defect in the on-site display during initialization, the following error messages can be displayed:

Message	Measure
Initialization, VU Electr. Defect A110	Replace on-site display.
Initialization, VU Electr. Defect A114	
Initialization, VU Electr. Defect A281	
Initialization, VU Checksum Err. A110	
Initialization, VU Checksum Err. A112	
Initialization, VU Checksum Err. A171	
Initialization	Supply voltage too low. Set supply voltage to the correct value.

9.2 Response of outputs to errors

The device differentiates between the message types "Alarm", "Warning" and "Error".
 → See the following table and Page 70, Section 8.1 "Messages".

Output	A (Alarm)	W (Warning)	E (Error: Alarm/Warning)
PROFIBUS	The process variable in question is transmitted with the status BAD.	Device continues measuring. The process variable in question is transmitted with the status 'Uncertain'.	For this error, you can enter whether the device should react as in the event of an alarm or as in the event of a warning. The output status is transmitted accordingly with the status BAD, UNCERTAIN, or GOOD. To configure the status for this error, you can configure the "SELECT ALARM TYPE" parameter (see BA00296P) or the relevant parameter in Fieldcare (menu path: PROFILE VIEW → PHYSICAL BLOCK → PB PARAMETER → PV STATUS CONFIG (→ Kap. 9.2.2)). Note: "GOOD" can only be configured as the status to be output via Fieldcare in the "PV STATUS CONFIG" menu path.
Bar graph (on-site display)	The bar graph assumes the values specified via the FAILSAFE MODE (FAIL_TYPE ¹) and the FAIL SAFE DEFAULT VALUE (FAIL SAFE DEFAULT VALUE ¹) parameters. → See also Section 8.2.1.	Device continues measuring.	For this error, you can enter whether the device should react as in the event of an alarm or as in the event of a warning. See corresponding "Alarm" or "Warning" column.
On-site display	<ul style="list-style-type: none"> - The measured value and message are displayed alternately - Measured value display:  -symbol is permanently displayed. Message display <ul style="list-style-type: none"> - A + 3-digit number such as A122 and - Description 	<ul style="list-style-type: none"> - The measured value and message are displayed alternately - Measured value display:  -symbol flashes. Message display: <ul style="list-style-type: none"> - W + 3-digit number such as W613 and - Description 	<ul style="list-style-type: none"> - The measured value and message are displayed alternately - Measured value display: see corresponding "Alarm" or "Warning" column Message display: <ul style="list-style-type: none"> - E + 3-digit number such as E713 and - Description
Remote operation (FieldCare)	In the case of an alarm, the ALARM STATUS ² parameter displays a 3-digit number such as 122 for "Sensor connection error, incorrect data".	In the case of a warning, the ALARM STATUS ² parameter displays a 3-digit number such as 613 for "Simulation is active".	In the case of an error, the ALARM STATUS ² parameter displays a 3-digit number such as 731 for "Pmax ALARM WINDOW undershot".

- Parameters are displayed via remote operation (e.g. FieldCare) only.
 Menu path: PROFILE VIEW → ANALOG INPUT BLOCK → AI PARAMETER → FAIL SAFE MODE
- Menu path on-site display: GROUP SELECTION → OPERATING MENU → DIAGNOSTICS → MESSAGES
 Menu path FieldCare: MANUFACTURER VIEW → OPERATING MENU → DIAGNOSTICS → MESSAGES

9.2.1 Analog Input Block

If the Analog Input Block receives an input or simulation value with the status BAD, the Analog Input Block uses the failsafe mode defined in the FSAFE_TYPE¹ parameter.

The following options are available by means of the FSAFE_TYPE¹ parameter:

- Last valid out val.
The last valid value is used for further processing with the status UNCERTAIN.
- FAIL SAFE DEFAULT VALUE
The value specified by means of the FAIL SAFE DEFAULT VALUE¹ parameter is used for further processing with the status UNCERTAIN.
- Status bad
The current value is used for further processing with the status BAD.

Factory setting:

- FAIL SAFE MODE¹: FAIL SAFE DEFAULT VALUE
- FAIL SAFE DEFAULT VALUE¹: 0
- The failsafe mode is also activated if the "Out of Service O/S" option was selected by means of the TARGET MODE² parameter.
- The FAIL SAFE MODE and FAIL SAFE DEFAULT VALUE parameters are available via remote operation (e.g. FieldCare) only.

1) Menu path: PROFILE VIEW → ANALOG INPUT BLOCK → AI PARAMETER

2) Menu path: PROFILE VIEW → ANALOG INPUT BLOCK → AI STANDARD PARAMETER

9.2.2 Setting the status of the flexible alarms

The event category can be individually defined for the following events - irrespective of the event group they are assigned to in the default setting:

- **115**: Sensor overpressure
- **120**: Sensor low pressure
- **715**: Sensor over temperature
- **716**: Process membrane broken
- **717**: Transmitter over temperature
- **718**: Transmitter under temperature
- **720**: Sensor under temperature
- **726**: Sensor temperature error - overrange
- **727**: Sensor pressure error - overrange
- **730**: LRV user limits exceeded
- **731**: URV user limits exceeded
- **732**: LRV Temp. User limits exceeded
- **733**: URV Temp. User limits exceeded
- **740**: Calculation overflow, bad configuration

To change the measured value status (Bad, Uncertain, Good) assigned to an event, select the desired status from the picklist.

Example

The status "Bad" should be used for error 115 "Sensor overpressure" instead of the status "Uncertain".

1. In the FieldCare navigation window, go to **PROFILE VIEW** → **PB Parameter**

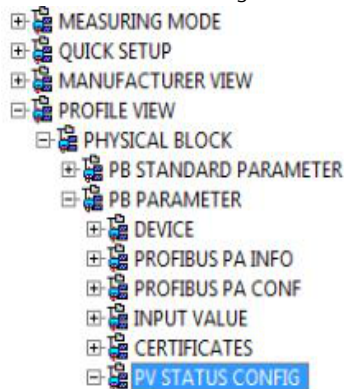

2. In the default setting, all the bits have "Uncertain" for "Status Select Events", apart from 716.



3. Select the "Bad" option for the row "Status Select Event 115". Press ENTER to confirm your entries.

9.3 Confirming messages

Depending on the settings for the ALARM DISPL. TIME and ACK. ALARM MODE parameters, the following measures should be taken to clear a message:

Settings ¹⁾	Measures
<ul style="list-style-type: none"> - ALARM DISPL. TIME = 0 s - ACK. ALARM MODE = Off 	<ul style="list-style-type: none"> - Rectify cause of the message (see also Section 8.1).
<ul style="list-style-type: none"> - ALARM DISPL. TIME > 0 s - ACK. ALARM MODE = Off 	<ul style="list-style-type: none"> - Rectify cause of the message (see also Section 8.1). - Wait for the alarm display time to elapse.
<ul style="list-style-type: none"> - ALARM DISPL. TIME = 0 s - ACK. ALARM MODE = On 	<ul style="list-style-type: none"> - Rectify cause of the message (see also Section 8.1). - Confirm message using ACK. ALARM parameter.
<ul style="list-style-type: none"> - ALARM DISPL. TIME > 0 s - ACK. ALARM MODE = On 	<ul style="list-style-type: none"> - Rectify cause of the message (see also Section 8.1). - Confirm message using ACK. ALARM parameter. - Wait for the alarm display time to elapse. If a message appears and the alarm display time elapses before the message has been acknowledged, the message will be cleared once it has been acknowledged.

1) The ALARM DISPL. TIME and ACK. ALARM MODE parameters are located in the MESSAGES menu.

9.4 Repair

The Endress+Hauser repairs concept provides for measuring instruments to have a modular design and also the customer may carry out repairs (→  81, "Spare parts").

- For certified devices, please consult the "Repair of Ex-certified devices" section.
- For more information on service and spare parts, contact the Endress+Hauser Service. (→ See www.endress.com/worldwide.)

9.5 Repair of Ex-certified devices

WARNING

Incorrect repair can compromise electrical safety!

Explosion hazard!

When repairing Ex-certified devices, please note the following:

- Repairs to Ex-certified devices must be carried out by Endress+Hauser Service or by specialist personnel according to national regulations.
- Relevant standards, national hazardous area regulations and Safety Instructions and Certificates must be observed.
- Only genuine Endress+Hauser spare parts may be used.
- When ordering spare parts, please check the device designation on the nameplate. Only replace parts with identical parts.
- Electronic inserts or sensors already in use in a standard instrument may not be used as spare parts for a certified device.
- Carry out repairs according to the instructions. After repairs, the device must fulfill the requirements of the specified individual tests.
- A certified device may only be converted into another certified variant by Endress+Hauser.

9.6 Spare parts

- Some replaceable measuring instrument components are identified by means of a spare part nameplate. This contains information about the spare part.
- All the spare parts for the measuring instrument, along with the order code, are listed in the W@M Device Viewer (www.endress.com/deviceviewer) and can be ordered here. If available, users can also download the associated Installation Instructions.



Measuring instrument serial number:

- Located on the device and spare part nameplate.
- Can be read out via the "DEVICE SERIAL No." parameter in the "TRANSMITTER DATA" submenu.

9.7 Returns

The measuring instrument must be returned if it is in need of repair or a factory calibration, or if the wrong measuring instrument has been delivered or ordered. Legal specifications require Endress+Hauser, as an ISO-certified company, to follow certain procedures when handling products that are in contact with the medium.

To ensure swift, safe and professional device returns, please read the return procedures and conditions on the Endress+Hauser website at www.services.endress.com/return-material.

9.8 Disposal

When disposing, ensure that the materials of the device components are separated and processed accordingly.

9.9 Software history

Date	Software version	Changes to the software
12.2004	03.00.zz	Original software. Compatible with: - Update ToF Tool – Field Tool® Package, version 2.03 or higher
05.2007	04.00.zz	- Operation via on-site display with three keys implemented. - New level modes "Level Easy Pressure" and "Level Easy Height" implemented. - DOWNLOAD FUNCTION parameter added to OPERATION group. - Factory settings for the "Error"-type messages redefined. - Chinese" and "Japanese" menu language included as standard. Compatible with: - FieldCare version 2.15.00 and higher
07.2013	04.01.zz	Profile 3.02 Integration

9.10 Hardware history

Date	Hardware version	Changes to hardware
05.2005	1.0	Original hardware
06.2007	1.10	Resistance inserted due to new requirements.
04.2008	02.00	Replacement of IC Media Access Unit

10 Technical data

For technical data, please refer to Technical Information Cerabar S TI00383P.

Index

A

Acyclic data exchange	40
Alarm messages	70

C

Cable specification	23
Cerabar S block model	35
Current consumption	23
Cyclic data exchange	35
Cyclic data telegram	37

D

Data format	47
Diaphragm seals, installation instructions	14
Diaphragm seals, vacuum application	15
Differential pressure measurement, Quick Setup menu	61
Display	24

E

Electrical connection	21
Error messages	70

F

Factory setting	54
FieldCare	51

G

Grounding	23
GSD files	33

H

Hazardous area	7
Heat insulation	15
HistoROM/M-DAT	51

I

Incoming acceptance	10
Input data, structure	37
Installation instructions for devices with diaphragm seals	14
Installation instructions for devices without diaphragm seals	11
Intended use	6

L

Level measurement	63
Level measurement, Quick Setup menu	65
Locking	53

M

Measuring arrangement for level measurement	14
Measuring arrangement for pressure measurement	12–14
Menu structure	48

N

Nameplate	8
Number of devices	28

O

On-site display	24
Operating elements, function	26–27
Operating elements, position	25
Operating keys, on-site, function	27
Operating keys, position	25
Operational safety	6
Output data, structure	37
Overvoltage protection	23

P

Pipe mounting	16
Position adjustment, on-site	26
Position adjustment, on-site display, FieldCare	60
Pressure measurement	61
Product safety	7
PROFIBUS PA system architecture	28

Q

Quick Setup menu level	65
Quick Setup menu pressure	61

R

Repair	81
Repair of Ex-certified devices	81
Reset	54
Returning devices	81
Rotating the housing	19

S

Safety instructions	6
Scaling OUT value	67
Scope of delivery	8
Selecting the language	58
Selecting the measuring mode	58
Separate housing, assemble and mount	17
Setting the device address	31
Shielding	23
Slot/index tables	41
Software history	82
Spare parts	81
Status code	38
Storage	10
Supply voltage	22
System integration	33
System integration (SET UNIT TO BUS)	68

T

Temperature isolator, installation instructions	15
Troubleshooting	70

U

Unlocking	53
-----------------	----

W

Wall mounting	16
Warnings	70
Welding recommendation	18
Workplace safety	6



71556693

www.addresses.endress.com
