

Operating Instructions

DUSTHUNTER SP100 Ex-2K

Scattered Light Dust Measuring Device



Described product

DUSTHUNTER SP100 Ex-2K

Version for potentially explosive atmospheres zone 1/21

Manufacturer

Endress+Hauser SICK GmbH+Co. KG
Bergener Ring 27
01458 Ottendorf-Okrilla
Germany

Legal information

This work is protected by copyright. Any rights derived from the copyright shall be reserved for Endress+Hauser SICK GmbH+Co. KG. Reproduction of this document or parts of this document is only permissible within the limits of the legal determination of Copyright Law. Any modification, abridgment or translation of this document is prohibited without the express written permission of Endress+Hauser SICK GmbH+Co. KG. The trademarks stated in this document are the property of their respective owner.

© Endress+Hauser SICK GmbH+Co. KG. All rights reserved.

Original document

This document is an original document of Endress+Hauser SICK GmbH+Co. KG.



Contents

1	About this document.....	8
1.1	Function of this document.....	8
1.2	Scope of application	8
1.3	Target groups	8
1.4	Further information.....	8
1.5	Symbols and document conventions	9
1.5.1	Warning symbols.....	9
1.5.2	Warning levels and signal words.....	9
1.5.3	Information symbols	10
1.6	Data integrity.....	10
2	For your safety.....	11
2.1	Basic safety information	11
2.2	Warning information on the device	15
2.2.1	Warning information on the sender/receiver unit.....	15
2.2.2	Warning information on the MCUDH Ex-3K control unit	16
2.3	Intended use	17
2.4	Responsibility of user.....	18
3	Product description	20
3.1	Product identification.....	20
3.2	Product characteristics	21
3.3	Layout and function	21
3.3.1	Functional principle	22
3.3.2	Protection concept.....	23
3.3.3	Sender/receiver unit DUSTHUNTER SP100 Ex-2K.....	24
3.3.4	MCUDH Ex-3K control unit	26
3.3.5	Flange with tube	28
3.3.6	Non-return valve	28
3.3.7	Connection line with Ex-Plug-Connector	29
3.3.8	Weather hood	29
3.3.9	Function check.....	30
3.4	Explosion protection in accordance with ATEX	32
3.4.1	Operation in Ex-area	32
3.5	Application illustration DUSTHUNTER SP100 Ex-2K	33
3.6	Interfaces	34
3.6.1	Standard interfaces of the MCUDH Ex-3K control unit	34
3.6.2	SOPAS ET user interface (PC program).....	35
4	Project planning.....	36
4.1	Device configuration	36
4.1.1	Selecting the sender/receiver unit	36
4.1.2	Selecting the flange with tube	37
4.1.3	Selecting the MCUDH Ex-3K control unit.....	37

4.2	Installation location	38
4.2.1	Project planning for measuring channel	38
4.2.2	Purge gas supply	40
4.2.3	Project checklist	41
5	Transport and storage.....	42
5.1	Transport.....	42
5.2	Storage.....	42
6	Assembly.....	43
6.1	Assembly information	43
6.1.1	Proper assembly.....	43
6.2	Preparing the measuring point	43
6.3	Scope of delivery	43
6.4	Installation sequence	44
6.4.1	Fitting the flange with tube	45
6.4.1.1	High-temperature version.....	46
6.4.1.2	Fitting a weather hood.....	47
6.4.2	Fitting the MCUDH Ex-3K control unit	48
7	Electrical installation.....	49
7.1	Electrical installation safety information	49
7.2	Connection overview	50
7.2.1	Connection overview	51
7.3	Information on connection lines	52
7.4	Connecting the sender/receiver unit.....	54
7.5	Connecting the control unit.....	54
7.5.1	MCUDH Ex-3K component layout	54
7.5.2	Work to be done	55
7.5.3	MCUDHEx-3K processor board connections.....	55
7.5.4	Connecting the connection line to the control unit	56
7.6	Installing the purge gas supply	57
7.7	Connecting Remote Display 100	58
7.7.1	Connection to the MCUDH Ex-3K control unit.....	58
7.7.2	Connection to the Remote Display 100	58
7.8	Connecting interfaces	59
7.8.1	Interface module (option) of the MCUDH Ex-3K	59
8	Commissioning.....	61
8.1	Safety information on commissioning	61
8.2	Requirements for commissioning.....	61
8.3	Inserting and switching on	62
8.3.1	Adapt the sender/receiver unit to the duct geometry	62
8.3.2	Fitting and connecting the sender/receiver unit	62
8.3.3	Start measuring operation	63
8.4	Recognizing the safe operating state	64

9	Configuring.....	65
9.1	Prerequisites	65
9.2	SOPAS ET	65
9.2.1	Install SOPAS ET	65
9.2.2	Password for SOPAS ET menus.....	65
9.2.3	Changing the password for SOPAS ET menus.....	66
9.3	Connecting to MCUDH Ex-3K control unit.....	66
9.3.1	Connect to the MCUDH Ex-3K control unit via the Service interface	66
9.3.2	Connect to the MCUDH Ex-3K control unit via Ethernet (option).....	67
9.3.3	Configuring the Interface module of the MCUDH Ex-3K control unit (option).....	68
9.3.4	Connecting a remote Ethernet Interface module.....	69
9.4	System configuration	70
9.4.1	Application parameters	70
9.4.2	Assigning the control unit to the sender/receiver unit	71
9.4.3	Factory settings.....	72
9.4.4	Determining the function check.....	73
9.4.5	Setting the analog outputs parameters.....	74
9.4.6	Setting the analog inputs parameters	76
9.4.7	Setting the response time	77
9.4.8	Calibration for dust concentration measurement.....	77
9.4.9	Changing display settings.....	79
9.5	Finding the DUSTHUNTER COM port	81
10	Operation	82
10.1	Operating concept.....	82
10.2	User groups	82
10.2.1	Changing the password for user groups.....	82
10.3	Displays and operating elements MCUDH Ex-3K	83
10.4	MCUDH Ex-3K control unit buttons	84
11	Menus	85
11.1	Menu tree for the explosion-proof MCUDH Ex-3K control unit.....	85
11.1.1	Menu tree “Menu”	85
11.1.2	Menu tree “Diagnosis”	86
11.2	Configuring on the control unit display	87
11.2.1	Configuring analog outputs and inputs of the control unit.....	87
11.2.2	Assigning the control unit to the sender/receiver unit	87
11.2.3	Enter the regression coefficients	87
12	Maintenance.....	88
12.1	Safety information.....	89
12.2	Data backup	90
12.2.1	Data backup in SOPAS ET	90

12.3	Maintenance plan.....	91
12.4	Consumables and spare parts.....	91
12.5	Maintenance on the sender/receiver unit.....	91
12.5.1	Cleaning the optics of the sender/receiver unit.....	92
12.5.2	Checking the contamination value.....	93
12.5.3	Non-return valve.....	94
12.5.4	Test equipment for linearity test.....	94
12.6	Maintenance work on the sender/receiver unit.....	95
12.6.1	Power supply without control unit.....	95
12.6.2	Checking laser alignment.....	96
12.6.3	Exchanging the protection tube O-ring.....	97
12.6.4	Exchanging the line inlet O-ring.....	97
12.6.5	Exchanging the copper seal in the cleaning opening.....	98
12.6.6	Exchanging the sinter filter.....	98
12.6.7	Exchanging the flange seal.....	99
12.6.8	Replace potential equalization screw.....	99
12.6.9	Exchanging the enclosure cover O-ring.....	99
12.6.10	Adjusting the duct geometry.....	100
12.6.11	Exchanging the protective hood.....	101
12.6.12	Exchanging the copper seal of the non-return valve.....	101
12.6.13	Exchanging the non-return valve.....	103
12.6.14	Exchanging the button cell in the control unit.....	103
12.6.15	Exchanging the Ex power supply unit.....	103
12.6.16	Exchanging the RS485 Interface module.....	104
13	Troubleshooting.....	106
13.1	Safety information.....	106
13.2	Monitoring and diagnostic system.....	107
13.3	Status display LEDs.....	107
13.4	Sender/receiver unit malfunctions.....	108
13.4.1	Malfunctions.....	108
13.4.2	Warning and malfunction messages.....	108
13.5	Control unit malfunctions.....	110
13.5.1	Malfunctions.....	110
13.5.2	Warning and malfunction messages.....	110
13.6	Troubleshooting measures.....	112
13.6.1	Setting the laser alignment.....	112
13.6.2	Checking the laser beam for free passage.....	113
13.6.3	Replacing the fuse.....	115
13.6.4	Sending in devices.....	115
14	Decommissioning.....	116
14.1	Switch-off states.....	116
14.2	Switching off and dismantling.....	116
14.3	Return delivery.....	117
14.4	Disposal.....	117

15	Technical data	118
15.1	Dimensional drawings and part numbers.....	121
15.1.1	DHSP100Ex-2K sender/receiver unit.....	121
15.1.2	Flange with tube	122
15.1.3	MCUDH Ex-3K control unit	123
16	Spare parts	124
16.1	Consumable parts.....	124
16.1.1	Consumable parts DUSTHUNTER SP100 Ex-2K.....	124
16.1.2	Consumable parts, MCUDH Ex-3K control unit	124
16.2	Spare parts.....	125
16.2.1	Spare parts DUSTHUNTER SP100 Ex-2K.....	125
16.2.2	Spare parts, MCUDH Ex-3K control unit	125
17	Accessories.....	126
17.1	Weather protection	126
17.2	Connection technology	126
17.2.1	Connection line with Ex-Plug-Connector	126
17.3	Fastening technology.....	126
17.4	Optional accessories.....	127
17.4.1	Options for MCUDH Ex-3K control unit	127
17.5	Other accessories	127
17.5.1	Device check accessories	127
18	Annex.....	128
18.1	Compliances.....	128
18.2	Electrical protection	128
18.3	Approvals.....	128
18.4	Licenses.....	129

1 About this document

1.1 Function of this document

These Operating Instructions describe:

- Device components
- Installation
- Operation
- Maintenance tasks necessary for safe operation

1.2 Scope of application

These Operating Instructions apply exclusively to the measuring system described in the product identification (see [“Product identification”, page 20](#)).

The Operating Instructions do not apply to other measuring devices from Endress+Hauser.

The standards mentioned in the Operating Instructions must be observed in their currently valid version.

1.3 Target groups

This Manual is intended for persons who install, operate and maintain the device.

Operation

The device may only be operated by authorized persons who, based on their device-specific training as well as knowledge of the relevant regulations, can assess the tasks given and recognize the hazards involved.

Installation and maintenance

Installation and maintenance may only be carried out by trained specialists familiar with the installation conditions.

Observe the information at the beginning of the respective Sections.

1.4 Further information





Refer to the enclosed product CD for further information.

- Final inspection protocol
- Conformity Declaration

1.5 Symbols and document conventions

1.5.1 Warning symbols

Table 1: Warning symbols

Symbol	Significance
	Hazard (general)
	Hazard by voltage
	Hazard by laser radiation
	Hazard in potentially explosive atmospheres
	Hazard for environment and organisms

1.5.2 Warning levels and signal words

DANGER

Risk or hazardous situation which *will* result in severe personal injury or death.

WARNING

Risk or hazardous situation which *could* result in severe personal injury or death.

CAUTION

Hazard or unsafe practice which *could* result in less severe or minor injuries.

NOTICE





Hazard which *could* result in property damage.

Note

Hints.

1.5.3 Information symbols

Table 2: Information symbols

Symbol	Significance
	Important technical information for this product
	Important information on electric or electronic functions
	Information on product condition with regard to protection against explosions (general)
	Information on product condition with regard to Explosion Protection Directive ATEX 2014/34/EU
	Additional information and explanations

1.6 Data integrity

Endress+Hauser uses standardized data interfaces, such as standard IP technology, in its products. The focus here is on product availability and features.

Endress+Hauser always assumes that the customer ensures the integrity and confidentiality of data and rights affected in connection with the use of the products.

In all cases, the customer is responsible for the implementation of safety measures suitable for the respective situation, e.g., network separation, firewalls, virus protection and patch management.

2 For your safety

2.1 Basic safety information

Work on the device



NOTICE:

Risk for system safety through work on the device not described in these Operating Instructions

Work on the device not described in the Operating Instructions or associated documents can lead to unsafe operation of the measuring system and thus endanger equipment safety.

- ▶ Only carry out the work described in these Operating Instructions and the corresponding documents on the device.



WARNING:

Injury risk through incorrect lifting and carrying of device components

Due to the mass of the device components, carelessness and mishandling during transport can lead to injuries.

- ▶ Consider the device component's weight before lifting.
- ▶ Observe the regulations for protective clothing (e.g., safety shoes, non-slip gloves).
- ▶ To carry the device components safely, use handles or reach under the component.
- ▶ Do not use protruding parts on device components for carrying.
- ▶ Call in further persons as assistants as required.
- ▶ Use a hoist or transport equipment as an option.
- ▶ Pay attention to the transport safety.
- ▶ Clear obstacles that could cause falls and collisions out of the way.

Hazards through hot or aggressive gases and high pressure

The DUSTHUNTER SP100 Ex-2K sender/receiver unit is fitted directly on the gas-carrying duct. On systems with a low hazard potential, installation or removal can be carried out during system operation when the applicable regulations and safety provisions of the system are observed, and necessary and appropriate protective measures are taken.



WARNING:

Health hazard due to sample gas and sample gas residues

When working on the sender/receiver unit, leaking gas can cause hazardous sample gas to escape from the duct and contaminate the enclosure.

- ▶ In systems with gases detrimental to health, high pressure, high operating temperatures or risk of explosions, the sender/receiver unit fitted on the duct may only be installed or removed when the system is at a standstill.
- ▶ When removing the sender/receiver unit from the duct, the sample gas supply must be interrupted and the opening in the duct closed with a blind flange. The purge gas supply remains.
- ▶ Before opening the gas paths: Take suitable safety measures (e.g., stop sample gas feed, purge gas paths with inert gas, protective clothing).
- ▶ Skin or eye contact with contaminated parts:
 - Observe the instructions of the respective Safety Data Sheet).
 - Consult a doctor.
- ▶ Remove sample gas residues: Purge all parts carrying sample gas with inert gas for a sufficiently long time.
- ▶ Remove solid and liquid residues.

**WARNING:****Health hazard due to hot sample gases and components**

Risk of skin burns through contact with hot sample gases and hot components

- ▶ In systems with high temperatures, work on the duct or hot assemblies should only be carried out when the system is shut down.
- ▶ Keep fitted valves and seals closed until cooled down.
- ▶ Allow enclosure parts or surfaces involved to cool down before touching.

When work is necessary on hot assemblies:

- ▶ Before opening gas paths or touching surfaces: Take suitable protective measures (e.g. personal protective equipment).
- ▶ Use heat-resistant tools.
- ▶ Keep disassembled hot components away from electrical components and lines. Allow to cool down at a protected place.

**WARNING:****Hazard through escaping gas or bursting components due to overpressure in the system**

High process pressure can damage components and lead to personal injury through bursting components or escaping health-endangering gas.

- ▶ Only use components designed for the process pressure in the application (see [“Technical data”, page 118](#)).
- ▶ Only carry out installation and maintenance of the device when the system is switched off.

**NOTICE:****Danger to operational safety at high temperatures**

The device can be damaged by high temperatures. The operator must take suitable measures to ensure the enclosure temperature does not exceed 60 °C.

- ▶ Avoid direct sunlight. If necessary, take measures to protect against the weather.
- ▶ If necessary, insulate the stack to prevent high temperatures.
- ▶ After one of the thermal cutout precautions has been triggered, the device must be returned to the factory to restore operational readiness.

**NOTICE:****Danger to operational safety in the event of visible damage**

Operating the measuring system with visible damage can further damage the measuring system or make it a source of danger.

- ▶ Check the components of the measuring system for external damage after each transport.
- ▶ If there is visible damage, do not put the measuring system into operation but send it in for repair (see [“Return delivery”, page 117](#)).

Hazards through electrical equipment

**WARNING:****Danger through power voltage**

There is a risk of electric shock when working on the system components.

- ▶ Ensure the power supply can be switched off at an easily accessible and marked power isolating switch and/or circuit breaker.
 - ▶ When working on the device:
 - Only have the work carried out by skilled electricians familiar with potential risks.
 - Take suitable protective measures against local hazards and hazards arising from the system (e.g., free room for movement, cable ducts, automatic switch on).
 - Disconnect power supply connections or power lines before working on the device.
 - Only allow personnel carrying out the work to activate the power supply under consideration of valid safety regulations.
 - ▶ Refit any contact protection removed before switching the power voltage back on again.
 - ▶ When replacing a removable power line: Observe the specifications (see “[Information on connection lines](#)”, page 52).
 - ▶ When device damage is visible: Switch the power supply off at the external point.
 - ▶ Only use electrical fuses corresponding to the stated ratings (design, breaking current, trigger characteristic).
-

Hazards through laser beam

**WARNING:****Hazard by laser radiation**

Laser class 2 device, health hazard in case of irradiation of eye or skin.

- ▶ Never look directly into the beam path.
 - ▶ Do not point the laser beam at persons.
 - ▶ Avoid laser beam reflections.
-

Hazards through explosive or combustible gases and dust

**WARNING:****Risk of explosion when using unsuitable tools within the Ex-area**

Unsuitable tools can be an ignition source when used.

- ▶ Only use tools approved for the Ex-area.
-

**WARNING:****Danger of explosion when working on device components within the Ex-area**

Sparking and static discharge can be a source of ignition.

- ▶ The device components may only be unpacked, transported, installed, assembled and disassembled outside the Ex-area.
 - ▶ Never take the packaging material into the Ex-area under any circumstances.
-

**WARNING:****Explosion hazard when work on the device requires opening the enclosure**

Work on the opened device enclosure assumes an Ex-free zone at the installation location otherwise there is an explosion risk.

- ▶ Ensure the working environment is not a Ex-area when working on the open device.
-

**WARNING:****Risk of explosion from escaping gas**

There is a risk of explosion due to escaping hot gases when the sender/receiver unit is pulled out of the duct or the maximum process pressure is exceeded.

- ▶ Only fit or remove device components when the system is shut down.
 - ▶ Observe the maximum permissible process pressure (see [“Technical data”](#), [page 118](#)), safe operation of the measuring system is not possible when this value is exceeded.
-

**CAUTION:****Risk of explosion through incorrect or missing potential equalization.**

Incorrectly connected potential equalization can generate potential differences that can lead to explosions in an Ex-atmosphere.

- ▶ Connect potential equalization to all planned points.
 - ▶ Ensure the potential equalization is connected during all work on the device described in the Operating Instructions.
-

**DANGER:****Risk of explosion when opening the MCUDH-Ex 3K control unit**

The MCUDH-Ex 3K control unit must not be opened in Ex-atmosphere until 3 minutes after switching off the power supply, so that the residual energy in the capacitors can dissipate.

- ▶ Do not open the MCUDH-Ex 3K control unit in an Ex atmosphere until after the waiting period.
 - ▶ Take suitable precautions to prevent dust from entering the control unit enclosure when the enclosure door is open.
-

2.2 Warning information on the device

2.2.1 Warning information on the sender/receiver unit

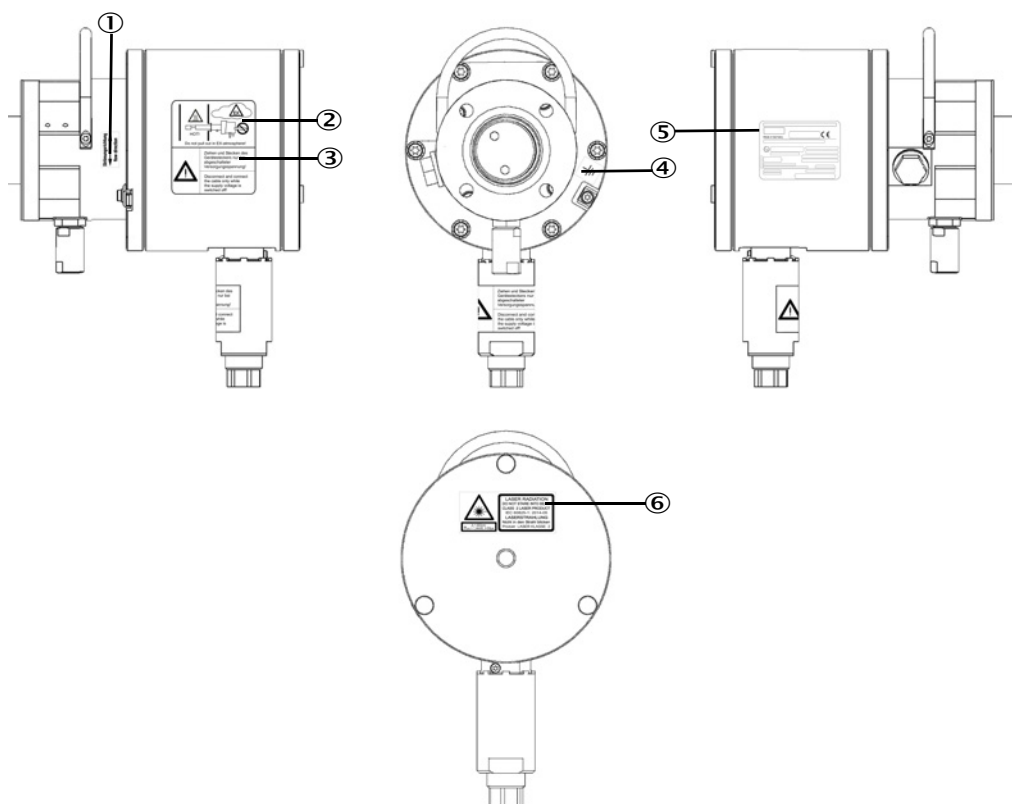

Fig. 1: Information on the sender/receiver unit DUSTHUNTER SP100 Ex-2K

Table 3: Significance of the information on the sender/receiver unit DUSTHUNTER SP100 Ex-2K

No.	Note
1	Information on aligning the device according to the flow direction in the duct (see "Adapt the sender/receiver unit to the duct geometry", page 62).
2	Risk of explosion: Do not remove the device from the duct if there is an explosive atmosphere.
3	Warning: Only pull and plug the connector plug when the supply voltage is switched off.
4	Information on the connection point of the potential equalization.
5	Type plate for clear identification of the device
6	Warning: Laser class 2, do not look into the beam.

2.2.2 Warning information on the MCUDH Ex-3K control unit

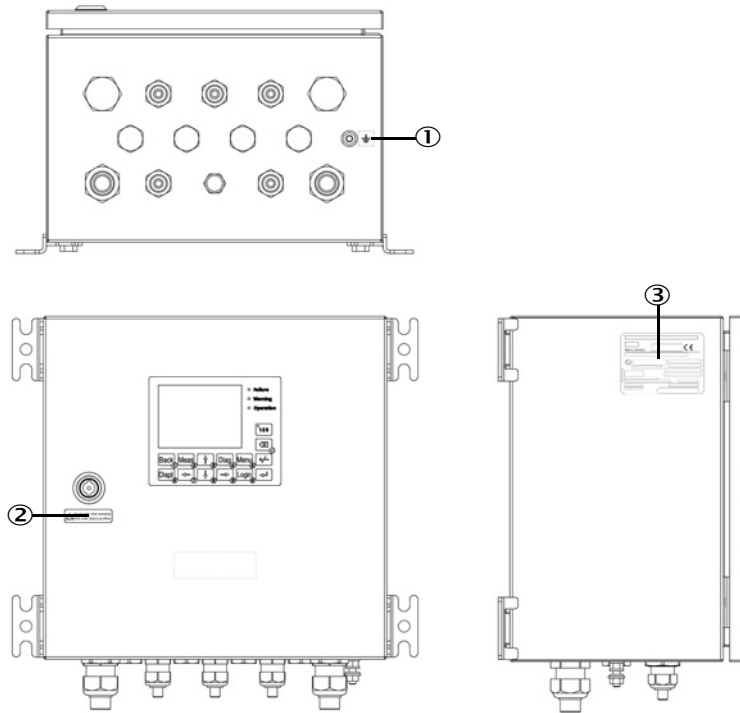

Fig. 2: Information on the MCUDH Ex-3K control unit - external

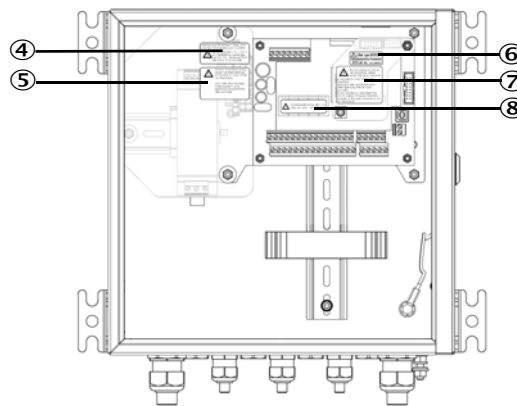

Fig. 3: Information on the MCUDH Ex-3K control unit - internal

Table 4: Significance of the information on the MCUDH Ex-3K control unit

No.	Note
1	Information on the potential equalization connection point.
2	Warning: Do not open the door of the MCUDH Ex-3K control unit until 3 minutes after switching off the power supply.
3	Type plate for clear identification of the device.
4	Information on the specifications of the fuses.
5	Warning: Do not remove or replace the fuse while the power is on.
6	Specifications regarding the button cell used.
7	Warning: Do not disconnect or change connectors and modules while they are live.
8	Information on the specifications of the relay contacts.

2.3 Intended use

Purpose of the system

The measuring system (see “Product description”, page 20) is designed as intended for use in industrial technical systems for continuous measurement of the dust load in gas flows. The device is used for both emission and process measurement and is intended for use in explosive gas or dust atmospheres.

Correct use

- The device should only be used as described in these Operating Instructions. The manufacturer bears no responsibility for any other use.
- Observe all measures necessary for conservation of value, e.g., for maintenance and inspection and/or transport and storage.
- No components may be removed, added or changed on and in the device unless described and specified in the official manufacturer information. Otherwise
 - the device could become dangerous
 - any warranty by the manufacturer becomes void.

Sender/receiver unit restrictions of use

The sender/receiver unit complies with ATEX category 2G and 2D and is only to be used in one of the corresponding areas (see “Application illustration DUSTHUNTER SP100 Ex-2K”, page 33).

The device identification is as follows:

DHSP-TxxxxEX2K (1/21)

ATEX II 2G Ex db op is IIC T6 Gb

II 2D Ex ib tb IIIC T85 °C Db

Control unit restrictions of use

The control unit complies with ATEX category 3G and 3D and is only to be used in one of the corresponding areas (see “Application illustration DUSTHUNTER SP100 Ex-2K”, page 33).

The device identification of the version with power supply unit is as follows:

MCUDH-NSxx

Ex II 3G Ex ec nA nC IIC T4 Gc

Ex II 3D Ex tc IIIC T85 °C Dc

The device identification of the version without power supply unit is as follows:

MCUDH-N2xx

Ex II 3G Ex ec IIC T4 Gc

Ex II 3D Ex tc IIIC T85 °C Dc



NOTE:

Observe the explosion protection directive:

- Installation, commissioning, maintenance and testing may be performed only by experienced persons with knowledge of the rules and regulations for potentially explosive atmospheres, particularly:
 - Ignition protection types and applicable standards
 - Installation regulations and zone classification

2.4 Responsibility of user

Avoiding damage

In order to avoid malfunctions that can cause direct or indirect personal injury or property damage, the operator must ensure:

- ▶ The maintenance personnel responsible can reach the site immediately, and at any time.
- ▶ The maintenance personnel are adequately qualified to react correctly to malfunctions of the measuring system and any resulting operational interruptions (e.g., when used for measurement and control purposes).
- ▶ The malfunctioning equipment is switched off immediately in case of doubt and that switching off does not cause collateral malfunctions.

Procedure for unsafe operating conditions

If the device is or could be in an unsafe state:

- ▶ Put the device out of operation.
- ▶ Disconnect the device from the power voltage and signal voltage.
- ▶ Secure the device against unallowed or unintentional start-up.

For further information, see [“Recognizing the safe operating state”, page 64](#).

Protection devices

According to the respective hazard potential:

- ▶ Suitable protective devices must be available.
- ▶ Personal safety equipment must be available in sufficient quantities.
- ▶ Personal safety equipment must be used by the personnel.

Purge gas

The purge gas supply serves to protect device-internal optical surfaces and internal parts against hot or aggressive gases. The supply must also be left switched on when the system is at a standstill. Optical subassemblies can be severely damaged in a short time or combustible gases can escape causing a risk of explosion when the purge gas supply fails (see [“Non-return valve”, page 28](#)). The user must ensure that:

- ▶ The purge gas supply runs reliably and continuously.
- ▶ A correct connection between the lines and connections is ensured and regularly checked.
- ▶ Suitable line material (preferably metal) is used and plug connections are avoided wherever possible.
- ▶ Failure of the purge gas supply is immediately detected (e.g., by using pressure monitors).
- ▶ The sender/receiver unit is removed from the duct and the duct opening is covered (e.g. with a blind flange in case of purging gas failure, taking into account explosion protection (see [“Fastening technology”, page 126](#))).

Preventive measures for operating safety

The user must ensure that:

- ▶ Neither failure nor erroneous measurements can lead to damaging or unsafe operating conditions.
- ▶ The specified maintenance and inspection tasks are carried out regularly by qualified, experienced personnel.

Correct project planning

- Basis of this Manual is the delivery of the device according to the preceding project planning and the relevant delivery state of the device (see delivered System Documentation).
 - ▶ Contact Endress+Hauser Service if you are not sure whether the device corresponds to the state defined during project planning or to the delivered system documentation.

Special local conditions

In addition to the information in these Operating Instructions, follow all local laws, technical rules and company-internal operating directives applicable wherever the device is installed.

Read the Operating Instructions

- ▶ Read and observe these Operating Instructions.
- ▶ Observe all safety information.
- ▶ If there is something you do not understand: Contact Endress+Hauser Service

Retention of documents

These Operating Instructions must be:

- ▶ Available for reference.
- ▶ Passed on to new owners.

3 Product description

3.1 Product identification

The measuring system comprises the components sender/receiver unit and control unit. The characteristics of the sender/receiver unit mainly determine the practical applicability of the measuring system, therefore the designation of the sender/receiver unit is the same as the designation of the measuring system. The selection of individual components is the responsibility of the operator of the measuring system.

Table 5: Product identification

Measuring system	DUSTHUNTER SP100 Ex-2K
Manufacturer	Endress+Hauser SICK GmbH+Co. KG Bergener Ring 27 · D-01458 Ottendorf-Okrilla · Germany
Components: Sender/receiver unit	DUSTHUNTER SP100 Ex-2K
Device version	Version for potentially explosive atmospheres zone 1/21
Type plate	Sender/receiver unit: On right side
Components: Control unit	MCUDH Ex-3K
Device version	Version for potentially explosive atmospheres zone 2/22
Type plate	Control unit: On left side

Type plates

Nr.	Variable
01	Type code
02, 03	Ambient temperature
04, 05	Gas temperature
06, 07	Gas pressure
08	Nominal length
09	Part number
10	Serial number
11	Data of manufacture
12	Data Matrix Code

Fig. 4: Type plate, sender/receiver unit and control unit (example)

Nr.	Variable
01	Data Matrix Code
02	Type code
03	Part number
04	Serial number
05	Date of manufacture

Fig. 5: Type plate, MCUDH control unit (example shows variant with power supply unit)

+i The MCUDH control unit without power supply unit has other values than those shown here in the example, see the Technical data (see “Technical data”, page 118).

With the help of the type plate, it is possible to identify the device and the possible areas of application perfectly by means of the explosion protection types.

3.2 Product characteristics

- The measuring system serves continuous measurement of dust particle concentrations in exhaust gas and exhaust air plants.
- The device is an in-situ measuring device which means measuring is done directly in the gas carrying duct.
- The sender/receiver unit is certified for use in explosion-hazardous areas of zones 1 and 21.
- The control unit is certified for use in zones 2 and 22.
- Measuring principle: Scattered light (forwards)

3.3 Layout and function

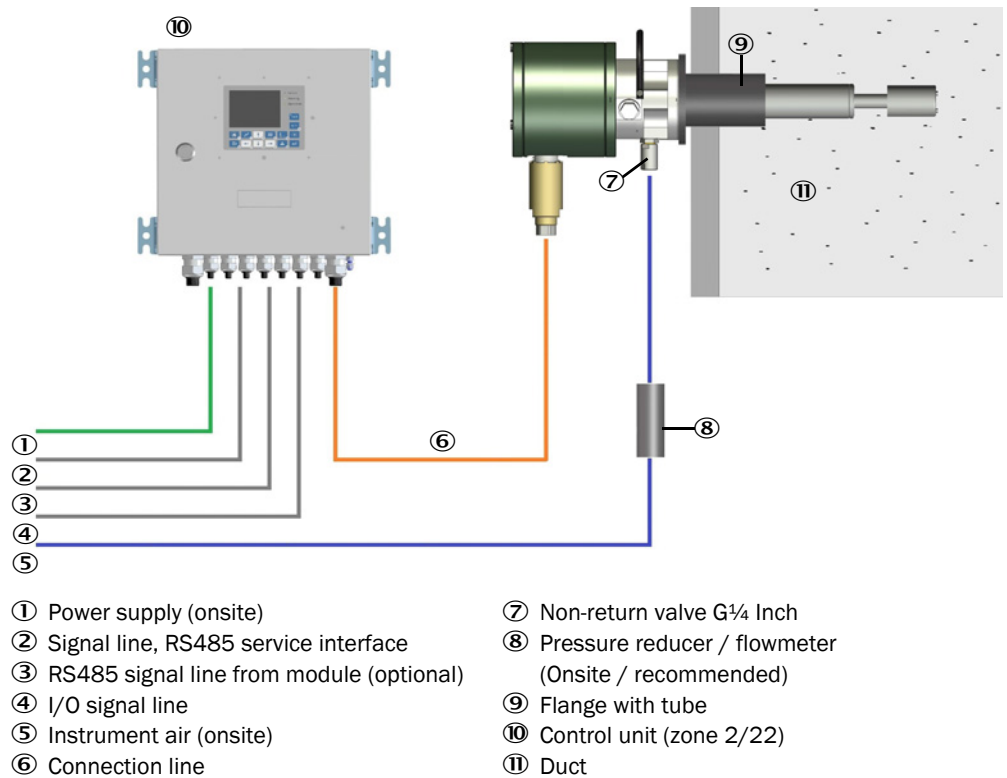

Fig. 6: DUSTHUNTER SP100 Ex-2K layout with zone 2/22 control unit

3.3.1 Functional principle

- The measuring system works according to the principle of scattered light measurement (forward scattering), the measuring volume in the gas duct is defined by the intersection of the sender beam and receive aperture.
- To maintain measuring reliability, a permanent gas flow (purge gas) keeps the optics free from dust particles as well as condensate.

Determining the dust concentration

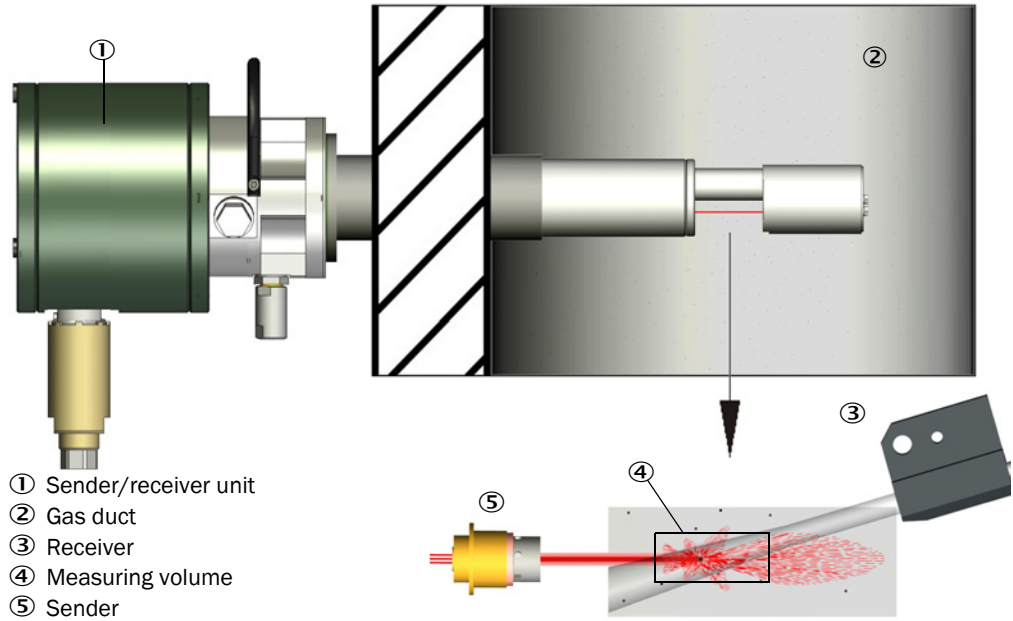

Fig. 7: Measuring principle

Measured scattered light intensity (SI) is proportional to dust concentration (c). Scattered light intensity not only depends on the number and size of particles but also on the optical characteristics of the particles and therefore the measuring system must be calibrated using a gravimetric comparison measurement for exact dust concentration measurement. The calibration coefficients determined can be entered directly in the measuring system as:

$$c = cc2 \cdot SI^2 + cc1 \cdot SI + cc0$$

(Entry see [“Calibration for dust concentration measurement”](#), page 77; standard factory setting: cc2 = 0, cc1 = 1, cc0 = 0).

3.3.2 Protection concept

Sender/receiver unit protection concept

The mechanical construction of the DUSTHUNTER SP100 Ex-2K is intended for use in explosive atmospheres of category 2G and 2D. The enclosure is dust-tight and the surface temperature limited. Thus the device corresponds to ignition protection type “t” (protection by enclosure). For this purpose, ignition protection type “d” (flameproof enclosure) is used, in which ignitable components are installed in an enclosure that can safely withstand the pressure of an explosion inside the enclosure. In the enclosure structure, the technologically required joints have also been designed so long and narrow that escaping hot gases lose their ignitability outside the enclosure. This means that the joint is flameproof and prevents the transmission of the explosion to the surrounding atmosphere. The device uses a laser to perform its measuring task. To avoid ignition of a potentially explosive atmosphere by optical radiation, the laser module meets the criteria of the type of protection inherently safe optical radiation “op is” according to EN60079-28. An inadmissible heating of the enclosure surface above the specified temperature class is also ruled out in the event of a fault by internal temperature fuses.

Thermal cutout

Thermal cutout mechanisms are built into the DUSTHUNTER SP100 Ex-2K sender/receiver unit. Further operation is prevented when the ambient temperature rises above or falls below the specified ambient temperature limits (see [“Technical data”, page 118](#)). Send the device back for a factory inspection when one of the two temperature limits has been exceeded (see [“Return delivery”, page 117](#)).



Take into consideration that the thermal cutout mechanisms refer to the permissible ambient temperature, not to the maximum surface temperature with regard to explosion protection, which is higher in this case.

Control unit protection concept

The MCUDH Ex-3K control unit is intended for use in explosive atmospheres of category 3G and 3D. Ignition protection types “ec” (increased safety) and “t” (protection by enclosure) are used. In addition, ignition protection types “nA” and “nC” are used on the versions with integrated power supply unit.

3.3.3 Sender/receiver unit DUSTHUNTER SP100 Ex-2K

The sender/receiver unit comprises two main subassemblies:

- **Electronics unit**
The assembly contains the optical and electronic subassemblies for sending the laser beam and receiving the scattered light.
- **Measuring probe**
The measuring probe is available in different versions and nominal lengths as well as for various gas temperature ranges and defines the device variant (see “Selecting the sender/receiver unit”, page 36).

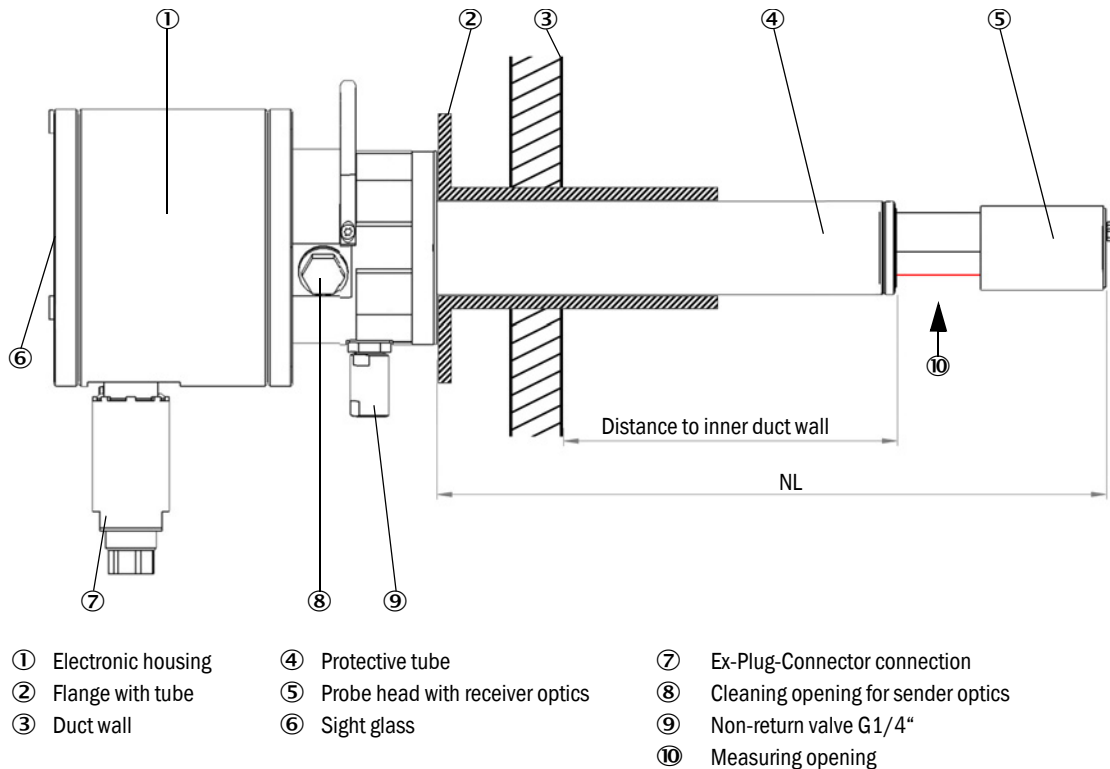

Fig. 8: DHSP-T2VxxEX2K sender/receiver unit



NOTE:

Distance to inner duct wall

The distance between internal duct wall and sender/receiver unit measuring opening should be at least 100 mm. For the high-temperature version, the distance should be between 100 mm and 140 mm so that the measuring device does not protrude too far into the duct and is not warmed up unnecessarily by the hot sample gas.

Sender/receiver unit type code

A type code identifies the special version of the sender/receiver unit:

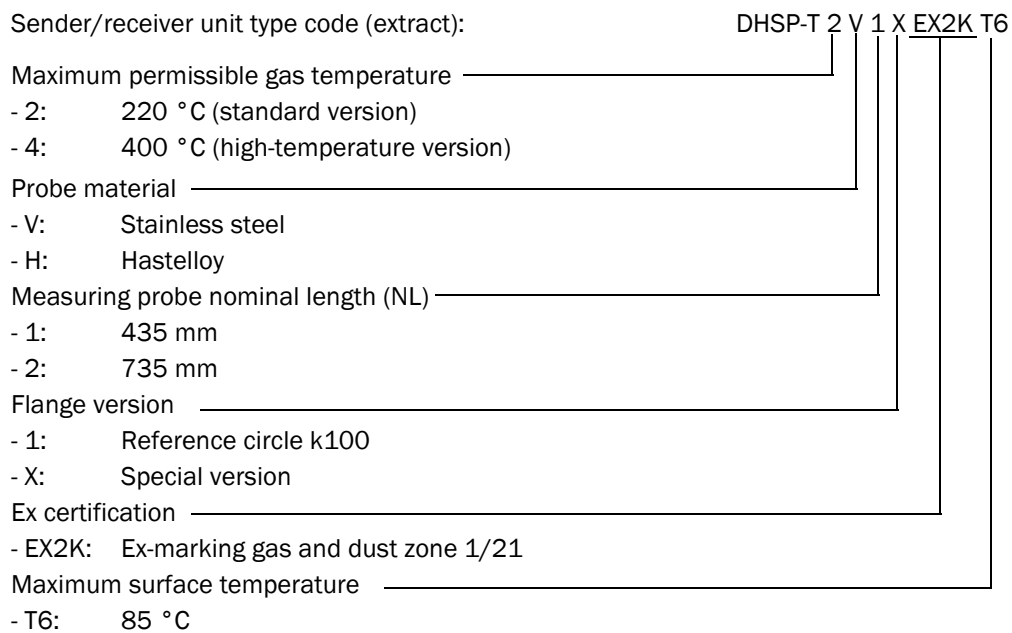

3.3.4 MCUDH Ex-3K control unit

The control unit serves as user interface for the DUSTHUNTER SP100 Ex-2K sender/receiver unit, prepares and outputs the measured values and also performs control and monitoring functions.

In detail, the control unit takes over the following tasks, for example:

- Sender/receiver unit power supply.
- Output of measured values, computed data and operating states
- Communication with the peripheral equipment
- Output of error messages and other status signals.
- Control of automatic test functions and access during service (diagnosis)

Via the service interface, the device parameters can be set using a computer and an operating program. The parameters are stored reliably even in the case of a power failure.



WARNING:

Risk of explosion when the USB service interface is used in an Ex-atmosphere.

Operation of the USB connector can cause an explosion.

- ▶ Using the USB service interface in an Ex-atmosphere is prohibited.
- ▶ If necessary, set up an alternative RS485 service interface that can be led into the safe area (see "Interfaces", page 34).

Use the control unit according to the intended areas of application (see "Application illustration DUSTHUNTER SP100 Ex-2K", page 33).

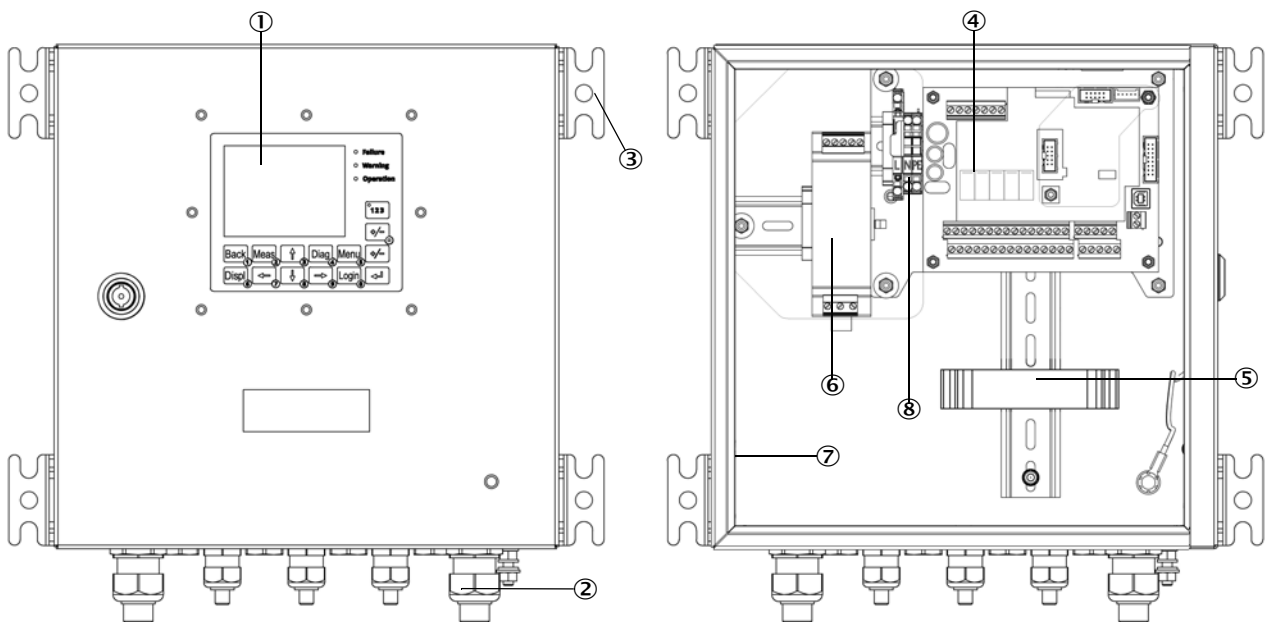

- | | |
|--|--------------------------------|
| ① Display module | ⑤ Interface module (option) |
| ② Cable and line inlets (2×M25; 5×M20) | ⑥ Power supply unit |
| ③ Fastening brackets | ⑦ Enclosure |
| ④ Processor board | ⑧ Terminal input, power supply |

Fig. 9: MCUDH Ex-3K control unit with options

3.3.5 Flange with tube

The flange with tube is attached directly to the gas duct of the measuring point and is used to mount the sender/receiver unit.

Purge gas supply

The sender/receiver unit must be purged with onsite purge gas. Purging protects the opto-electronic components from contamination and excessive gas temperatures. Take into consideration that purge gas consumption is higher in the high-temperature version (see “Purge gas supply”, page 40).

The manufacturer recommends the use of a float-type flowmeter and a pressure reducer (see “DHSP-T2VxxEX2K sender/receiver unit”, page 24) to adjust and control the purge gas demand, because an undersupply or failure of the purge gas supply can lead to equipment damage. If necessary, an additional nozzle can be used to stabilize the purge gas quantity.

Purge gas hose (antistatic)

The purge gas hose is used to supply purge gas to the sender/receiver unit. On the device side, the purge gas hose is connected to the G $\frac{1}{4}$ " non-return valve. The operator must ensure a suitable and uninterrupted purge gas supply (see “Purge gas supply”, page 40), including a suitable purge gas hose. It is mandatory to provide an antistatic purge gas hose due to the danger of explosion in the event of electrostatic discharge.

3.3.6 Non-return valve

The non-return valve protects the sender/receiver unit against high temperatures and sample gas for a short time (up to 15 minutes) should the purge gas supply fail.

**WARNING:****Risk of explosion through purge gas failure**

Explosive gases may escape in case of purge gas failure.

- ▶ The sender/receiver unit must be disconnected immediately from the power supply when a purge gas failure occurs.
 - ▶ To avoid damage to the device, the sender/receiver unit must be removed from the duct, but only if this does not create a risk of explosion or danger to employees.
-

**NOTICE:****Device damage possible in case of purge gas failure**

During longer operation (> 15 minutes) without purge gas supply, there is a risk that components relevant to ignition protection (seals and adhesives) may lose their sealing function or fatigue strength completely or partially. If the device is connected to the duct without purge gas supply for a longer period of time, the device must be sent to the factory immediately for testing.

3.3.7 Connection line with Ex-Plug-Connector

The DUSTHUNTER SP100 Ex-2K is connected to the control unit with a special plug connector, the “Ex-Plug-Connector”. The plug connector for the measuring device side is equipped with a pressure-resistant, dust-proof housing which is screwed over the plug after connecting the measuring device and secured with a screw and is part of the protection concept. The connection line with the Ex-plug connector is available in different lengths (see [“Connection technology”, page 126](#)). The operator is responsible for assessing the suitability of the connecting cables to be used in explosion-proof areas.



Fig. 10: Ex-Plug-Connector with transport protection

3.3.8 Weather hood

When mounting the sender/receiver unit outdoors, a weather hood is strongly recommended as protection against sunlight and weather (see [“Weather protection”, page 126](#)).

3.3.9 Function check

A function check can be triggered at fixed intervals to automatically check the function (check cycle) of the measuring system. The start time for the automatic function check begins when the device is switched on. Any unallowed deviations from normal behavior that may occur during function monitoring are signaled as errors. A function check triggered manually can help localize possible error causes should a device malfunction occur.

The function check comprises:

- Approx. 45 s measurement of zero value, control value and contamination of optical surfaces
The measuring time depends on the increase in contamination value (change > 0.5% → measurement is repeated up to 2 times).
- Every 90 s (standard value) output of values determined (duration parameter can be modified, see “Determining the function check”, page 73).

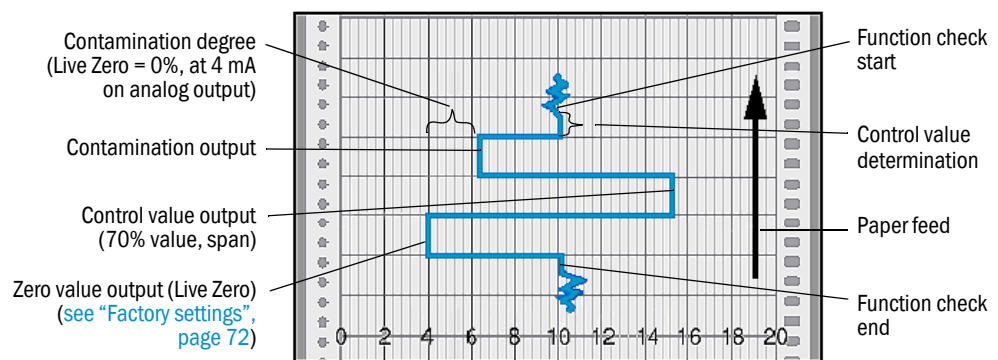

Fig. 11: Function check output on a plotter



- The analog output must be activated to output control values on the analog output (see “Setting the analog outputs parameters”, page 74).
- The value measured last is output on the analog output during control value determination.
- If the control values are not output on the analog output, the current measured value is output when control value determination has completed.
- “Function control” is displayed on the control unit display during the function check.
- A function check is not started automatically when the measuring system is in “Maintenance” mode.
- If the cycle interval is changed, a check cycle timed between parameter setting and new start timepoint is still carried out.
- Changes to the interval time are first effective after the next start timepoint.

Zero value measurement

The sender diode is switched off for zero point control so that no signal is received. This means possible drifts or zero point deviations are detected reliably in the overall system (e.g., due to an electronic defect). A warning signal is generated when the “zero value” is outside the specified range.

Control value measurement (span test)

Sender beam intensity changes between 70 and 100% during control value determination. The brightness of the light signal in the measuring circuit (“measuring signal”) is compared with the brightness in an independent internal reference channel (“monitor signal”). The measuring system generates an error signal for deviations greater than $\pm 2\%$. The error

message is cleared again when the next functional check runs successfully. The control value is determined with high precision through statistical evaluation of a high number of intensity changes.

Contamination measurement

For contamination measurement, the receiver optics is swiveled into a control position and the scattered light intensity measured. The measured value determined and the reference value defined as factory setting are used to calculate a correction factor. This fully compensates any contamination that occurs.

A value between live zero and 20 mA, proportional to the contamination, is output on the analog output for contamination values < 40% ; when this value is exceeded, the “Malfunction” status is output and on the analog output the set error current (see “[Setting the analog outputs parameters](#)”, page 74).

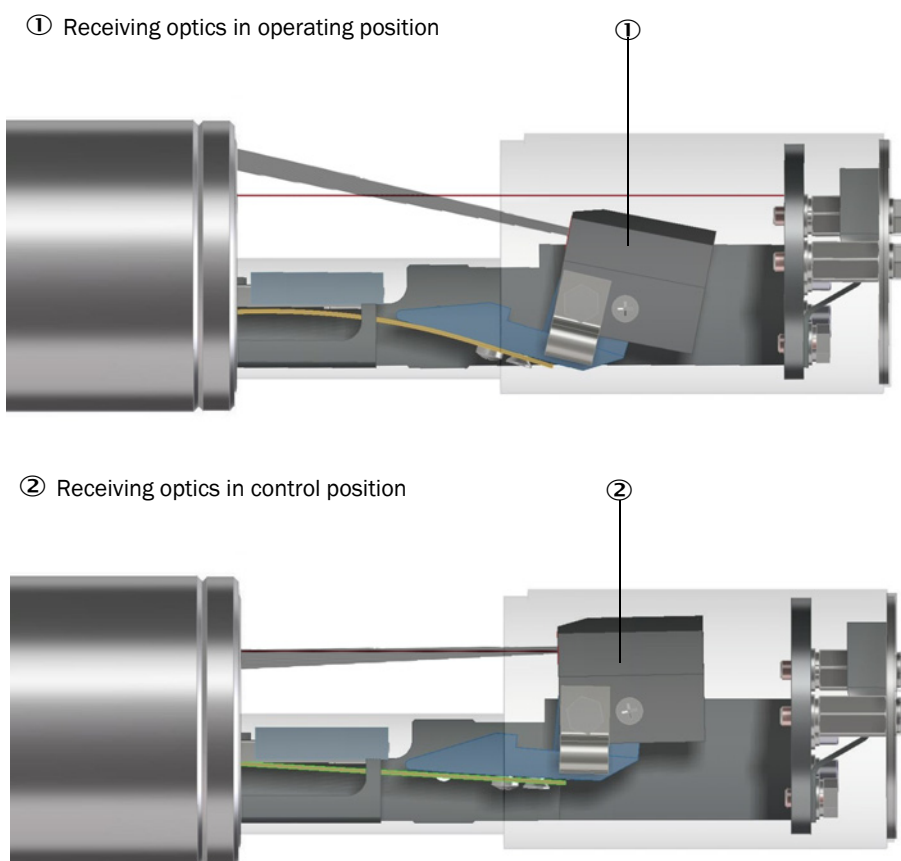

Fig. 12: Contamination and control value measurement

Cycle restriction

The measuring system contains wearing parts which are stressed by device functions and must be replaced after a certain number of traverses in order to permanently guarantee the ignition protection of the system. A warning message is generated after 12,000 function check cycles (see “[Determining the function check](#)”, page 73) and an error message after 15,000 cycles. The measuring system must be sent in between these times for factory inspection.

3.4 Explosion protection in accordance with ATEX

3.4.1 Operation in Ex-area



DUSTHUNTER SP100 Ex-2K sender/receiver unit

The marking of the electrical explosion-proof device is:
ATEX II 2G Ex db op is IIC T6 Gb / ATEX II 2D Ex tb op is IIIC T85 °C Db

- The marking is on the type plate
- EU Type Examination Certificate: BVS 20 ATEX E 074 X
IECEX BVS 20.0079X
- The thermal insulation is an explosion protection measure to be subjected to special examination for media temperatures higher than the surface temperature allowed by the selected temperature class. Observe the following during this examination:
 - Parts of the device surface that can be subjected to prohibited high temperatures due to the media temperatures must be included in the insulation or the heat conduction must be prevented.
 - It must be ensured that the surface temperature of the flameproof device remains below 60 °C. At nominal operation, the internal heating of the device can be up to 2 K.
 - The dimensions of the flameproof joints of this equipment are partly longer and the joint widths of the flameproof joints partly smaller than required by EN 60079-1:2014, Table 2 (3).

It must be ensured that the dust measuring device is permanently supplied with purge gas.



MCUDH Ex-3K control unit

The marking of the electrical explosion-proof device depends on the device selection (see "Technical data", page 118).

- The marking is on the type plate
- EU-Type Examination Certificate: BVS 20 ATEX E 043 X
Letter "X" after the certificate number indicates the following special condition for the safe use of the device:
 - It must be ensured that the transient protection is set to a value not exceeding 140% of the measured peak voltage on the supply terminals of the device.
 - Only operate the device at maximum with degree of contamination 2.



NOTE:

Hazard when operating in potentially explosive atmospheres

Risk of explosion when regulations on explosion protection are not observed during operation.

- ▶ Only use the measuring system in potentially explosive atmospheres according to the device identification (see "Intended use", page 17).
- ▶ Only use the measuring system within the temperature limits as specified in these Operating Instructions as well as on the type plate.
The specified values must not be exceeded even for brief periods.
- ▶ The use of the measuring system with hybrid mixtures (mixture of combustible gases or vapors with dust) must be evaluated according to the situation being considered, e.g. regarding concentration limits or energy and temperature limits.
- ▶ Do not install any components, apart from the electronics unit of the sender/receiver unit, in lines, tanks, or other installation areas where explosive gas and/or dust mixtures may be present.
- ▶ The measuring system must not be operated with dust deposits thicker than 5 mm on the electronics housing.
- ▶ Dust deposits must be removed regularly and properly.

3.5 Application illustration DUSTHUNTER SP100 Ex-2K

The application illustration shows the possible constellation of the DUSTHUNTER SP100 Ex-2K with the MCUDH Ex-3K control unit.

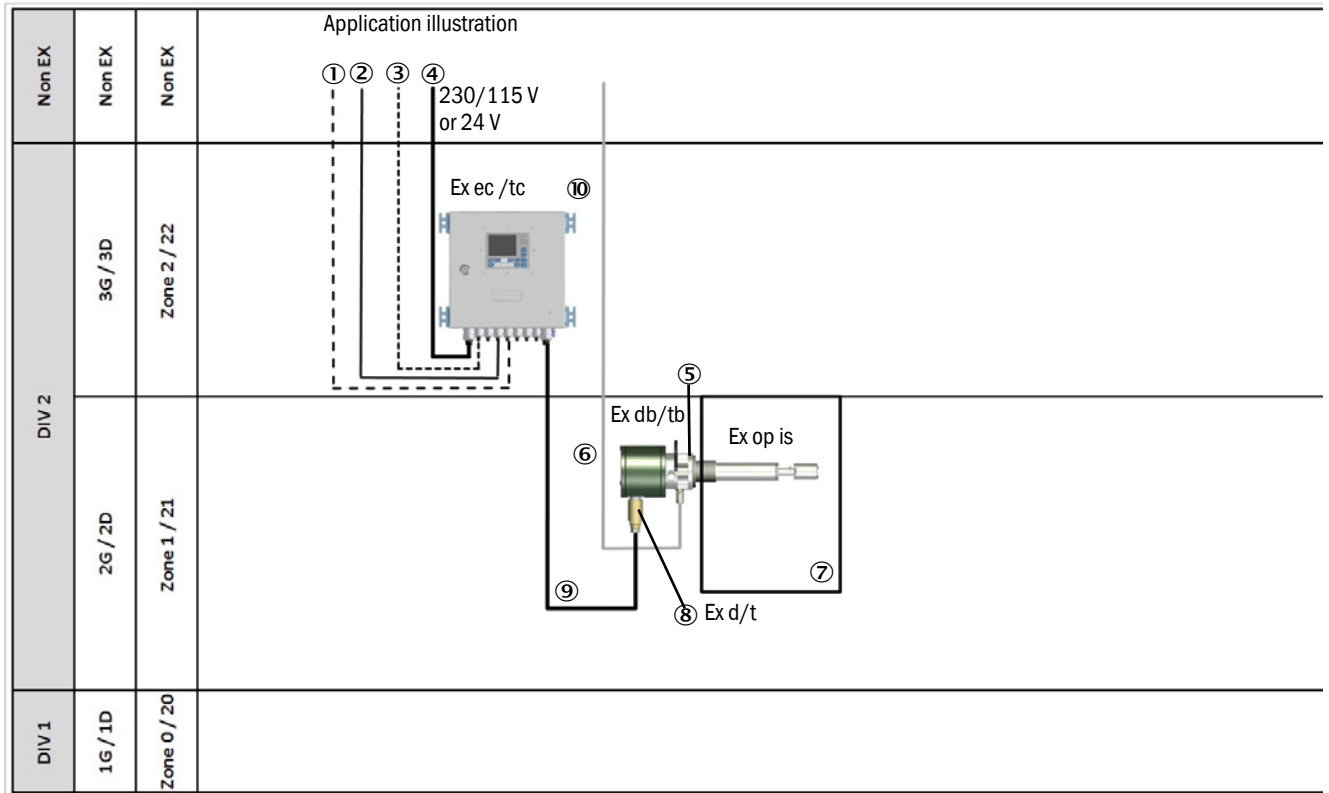

- ① Service interface
- ② Line for measured value transmission
- ③ Data interface (when using optional interface module)
- ④ Voltage supply
- ⑤ DUSTHUNTER SP100 Ex-2K (sender/receiver unit for zone 1/21)
- ⑥ Purge gas hose (antistatic)
- ⑦ Measuring channel
- ⑧ Connection line with Ex-Plug-Connector
- ⑨ Connection line from control unit to sender/receiver unit
- ⑩ MCUDH Ex-3K (control unit for zone 2/22)

Fig. 13: Application illustration with application variant DUSTHUNTER SP100 Ex-2K

3.6 Interfaces

Communication between sender/receiver unit and control unit

As standard, each sender/receiver unit is connected to a control unit via the connection line.

Data transfer to the MCUDH Ex-3K control unit and the power supply (24 V DC) from the MCUDH Ex-3K control unit run via a 4-lead shielded line with plug-in connector.

The MCUDH Ex-3K USB interface can only be used in the Ex-free zone, because opening the control unit while it is live is not permitted in the Ex-area. Alternatively, an RS485 service interface is connected to terminals 43 and 44 (see [“Connection overview”, page 51](#)). A line up to 1000 m long can be routed from the above-mentioned connection terminals through an unused cable duct into the safe area. Please note that the service and USB interfaces cannot be operated simultaneously.

3.6.1 Standard interfaces of the MCUDH Ex-3K control unit

Table 6: Standard interfaces of the MCUDH Ex-3K control unit

Analog output	1 output 0/2/4...22 mA (electrically isolated; active; resolution 10 bits) to output: Scattered light intensity (corresponds to the uncalibrated dust concentration), calibrated dust concentration, scaled dust concentration.
Analog inputs	2 inputs 0...20 mA (standard; without electric isolation; resolution 10 bits).
Relay outputs	5 changeover contacts (48 V, 1 A) to output status signals: Operation/malfunction; maintenance; function check; maintenance request; limit value.
Digital inputs	4 inputs to connect potential-free contacts (e.g. to connect a maintenance switch, trigger a function check or further actions).
Communication	USB 1.1 (use only outside the Ex-area). RS485 service interface (on connection terminals) for measured value enquiry, parameter setting and software update. Internal RS485 interface for communication between sender/receiver unit and control unit.

Optional interfaces for the MCUDH Ex-3K control unit

Additional options can be integrated to extend the functional scope of the MCUDH Ex-3K control unit (see [“Options for MCUDH Ex-3K control unit”, page 127](#)).

- **Fieldbus module**

The RS485 interface module for the transmission of Modbus ASCII/RTU or CoLa-B (protocol SOPAS-ET) serves to forward measured values, system status and service information to higher-level control systems. A ribbon cable serves to connect the module to the processor board. An RS485 signal line up to 1000 m long can be connected to the module, which can then be led out of the Ex-zone. The RS485 signal line can then be converted to Ethernet in the safe area using the following fieldbus modules: Ethernet Service Type 2 or Modbus® TCP (remote modules with separate 24 V supply).

- **Remote Display 100**

The Remote Display 100 offers identical functions as the MCUDH Ex-3K control unit, but can be mounted further away.

- Operating functions as on MCUDH Ex-3K display
- Distance to the device: Observe the minimum cable cross section (max. current: 0.15 A, min. voltage: 20 V on the display).

The MCUDH Ex-3K and the Remote Display 100 are locked against each other, both devices cannot be operated at the same time.

3.6.2 SOPAS ET user interface (PC program)

SOPAS ET is a SICK software for easy operation and configuration of DUSTHUNTER measuring devices. Further functions are also available (e.g., data storage, graphic displays).

SOPAS ET runs on a computer connected via an interface to the control unit of the DUSTHUNTER measuring system (see [“SOPAS ET”, page 65](#)).

SOPAS ET is delivered on the product CD.

4 Project planning

4.1 Device configuration

The device components required for a measuring system depend on the respective application conditions. The following Section can help you with your selection.

4.1.1 Selecting the sender/receiver unit

Selection of the suitable sender/receiver unit depends on the wall and insulation thickness of the duct and the composition and temperature of the sample gas.

Table 7: Sender/receiver unit selection Table

Wall and insulation thickness [mm]	Nominal length NL [mm]	Protective tube length [mm]	Exhaust gas, exhaust air		Sender/receiver unit type
			Max. temperature in °C	Composition	
Max. 100	435	300	220	Non-corrosive/ low corrosion	DHSP-T2V11EX2K
				Corrosive	DHSP-T2H11EX2K
			400	Non-corrosive/ low corrosion	DHSP-T4V11EX2K
Max. 400	735	600	220	Non-corrosive/ low corrosion	DHSP-T2V21EX2K
			400	Non-corrosive/ low corrosion	DHSP-T4V21EX2K
Further variants available on request					



- Select the nominal length of the sender/receiver unit so that the measuring opening is an adequate distance away from the internal duct wall.
 - Standard version clearance: At least 100 mm.
 - High-temperature version clearance: Between 100 mm and 140 mm so that the measuring device does not protrude too far into the duct and is not warmed up unnecessarily by the hot sample gas.
- The selected nominal length of the sender/receiver unit should only be as long as necessary, the measuring opening (see “DHSP-T2VxxEX2K sender/receiver unit”, page 24) need not be in the middle of the duct.
- Observe the maximum permissible process pressure (see “Technical data”, page 118), safe operation of the measuring system is not possible when this value is exceeded.
- Limit values for corrosive gas composition (standard values assuming normal pressure and temperature conditions, use lower values for mixtures of several components):
 - HCl: 10 mg/m³
 - SO₂: 800 mg/m³
 - SO₃: 300 mg/m³
 - NO_x: 1000 mg/m³
 - HF: 10 mg/m³

4.1.2 Selecting the flange with tube

The selection of a suitable flange with tube depends on the wall and insulation thickness of the duct wall, the nominal length of the selected sender/receiver unit and the sample gas temperature. Flanges with tube are available which are delivered with a 3.1 material certificate (see “Flange with tube”, page 122). The material pairing of the duct and the tube should also be taken into account when a welded connection between the flange with tube and duct is planned.

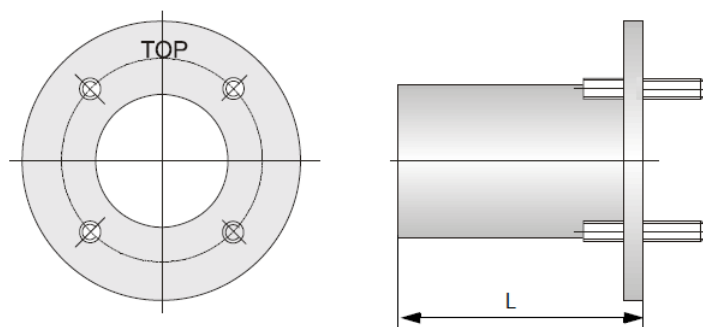

Gas temperature	Nominal length of sender/receiver unit		Nominal length of flange with tube (mm)
	435 mm	735 mm	
< 150 °C	130, 240	130, 240, 500	
> 150 °C	240	500	

Fig. 14: Flange with tube

4.1.3 Selecting the MCUDH Ex-3K control unit

Selection of the MCUDH Ex-3K control unit depends on the required power supply unit and the optional field bus module (see “Interfaces”, page 34). The control units are suitable for operation in Ex-zones 2/22.

Table 8: Selection Table for MCUDH Ex-3K control unit

Power supply unit	Fieldbus module	Type designation
Without (24 V DC)	No Fieldbus module	MCUDH N2YDN00000NNOE
Switchable 115 / 230 V AC		MCUDH NSYDN00000NNOE
Without (24 V DC)	Modbus RTU (RS485).	MCUDH N2YDN00000MNOE
Switchable 115 / 230 V AC		MCUDH NSYDN00000MNOE

4.2 Installation location

4.2.1 Project planning for measuring channel

Electrical connection

Ensure the device can be switched off with a power isolating switch or circuit breaker in accordance with EN 61010-1. The potential equalization line of the sender/receiver unit at the measuring point must be flexible enough to allow the line to remain connected both when the sender/receiver unit is removed and installed.

Determining the measuring point

The operator is responsible for determining the measuring point. For official measurements, the regulations of the local authorities must be observed. Furthermore, it is important to ensure an uninterrupted supply of purge gas and to maintain sufficient space for the installation and subsequent fitting and removing the sender/receiver unit.

Required thermal insulation

The thermal insulation is an explosion protection measure to be subjected to special examination when gas temperatures in the duct are higher than the surface temperature allowed by the selected temperature class. Observe the following during this examination:

- Apart from the duct surface, other parts (e.g. flange tube and flange) that can be subjected to prohibited high temperatures through thermal conduction are to be included in the insulation or the thermal conduction prevented.
- The operator must ensure that suitable insulation reduces the heat radiation sufficiently so that the flameproof enclosure temperature remains below 85 °C and therefore below the temperature for the temperature protection class. The operator must take into consideration that the device-internal warming can be up to 2K. It may be necessary to shade the device in climate zones with high temperatures and intensive sunlight.
- The maximum ambient temperature of 60 °C must be observed during project planning and operation (see [“Technical data”, page 118](#)).

Miscellaneous.

- The operator must ensure that the dust measuring device is permanently supplied with purge gas.
- The operator is responsible for the tightness of the purge gas line between the device, connecting pieces and flange and for monitoring the tightness.
- Ensure sufficient ventilation at the installation site.
- The operator must ensure that no hot process gas can escape from the duct when removing the sender/receiver unit from the duct or that there is no potentially explosive atmosphere.

Sender/receiver unit space requirements

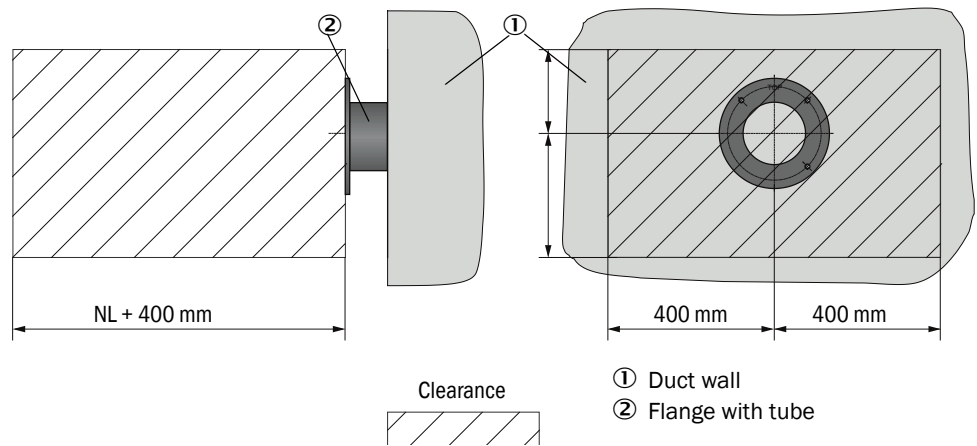

Fig. 15: Clearance for the sender/receiver unit

When determining the installation location of the sender/receiver unit, make sure the device is aligned with the flow direction in the duct (see “Adapt the sender/receiver unit to the duct geometry”, page 62).

MCUDH Ex-3K control unit space requirements

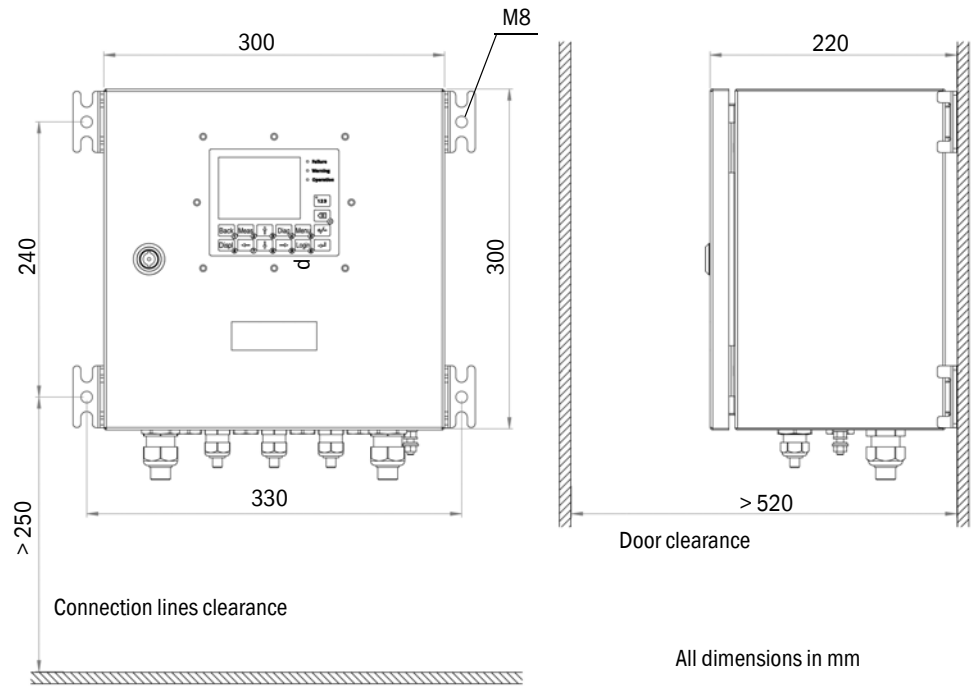

Fig. 16: MCUDH Ex-3K control unit clearance

4.2.2 Purge gas supply

Table 9: Purge gas supply

Internal duct pressure P_{abs} [hPa]	Connection and supply components
	Purge gas on G $\frac{1}{4}$ " non-return valve
0...+3000	The operator is responsible for selecting and evaluating a suitable purge gas.

Purge gas requirement

Standard version: 3...5 m³/h

High-temperature version: 18 m³/h

The manufacturer recommends using a float flowmeter and a pressure reducer to set and control the purge gas requirement. If necessary, an additional nozzle can be used to stabilize the purge gas quantity.

Purge gas quality

It may be necessary to use alternative purge gases other than the ambient air depending on the application or process parameters. The operator is responsible for assessing technical, qualitative and safety-relevant aspects with regard to the use of an alternative purge gas.

4.2.3 Project checklist

The following Table provides an overview of project planning work necessary as prerequisite for trouble-free assembly and subsequent device functionality. You can use this table as a checklist and tick off the completed steps.

Table 10: Project checklist

Task	Requirements	Work step	<input checked="" type="checkbox"/>
Determine measuring and installation locations for device components	Inlet and outlet piping in accordance with DIN EN 13284-1 - Inlet at least $5 \times d_h$ (hydraulic diameter) - Outlet at least $3 \times d_h$ - Distance from stack opening at least $5 \times d_h$ For round and square ducts: $d_h = \text{duct diameter}$ For rectangular ducts: $d_h = 4 \times A (\text{surface}) \div U (\text{circumference})$	Follow specifications for new systems Select best possible location for existing systems. For too short inlet/outlet paths: Inlet path > outlet path	<input type="checkbox"/>
	Homogeneous flow distribution / representative dust distribution - Whenever possible, no deflections, cross-section variations, feed and drain lines, flaps or fittings in the area of the inlet and outlet paths	If conditions cannot be ensured: Define flow profile in accordance with DIN EN 13284-1 and select best possible location.	<input type="checkbox"/>
	Sender/receiver unit fitting location and alignment - No vertical mounting on horizontal or inclined ducts, max. angle of the measuring axis to the horizontal 45° - Observe alignment to flow direction (see “Adapt the sender/receiver unit to the duct geometry” , page 62)	Select best possible location Provide information on duct direction.	<input type="checkbox"/>
	Accessibility, accident prevention - Device components must be safely accessible	Provide platforms or pedestals as required.	<input type="checkbox"/>
	Installation free of vibrations - Acceleration < 1 g	Take suitable measures to eliminate/reduce vibrations.	<input type="checkbox"/>
	Ambient conditions - Limit values according to Technical Data (see “Technical data” , page 118)	If necessary, provide weather protection (see “Weather hood” , page 29), enclose or lag components.	<input type="checkbox"/>
	Consider lines and hoses at the installation site (see “Connection line with Ex-Plug-Connector” , page 126) Observe the application illustration (see “Application illustration DUSTHUNTER SP100 Ex-2K” , page 33) with regard to the installation locations.	Observe line and hose lengths. Select the best possible location, potential equalization line must allow removing the sender/receiver from the duct when connected.	<input type="checkbox"/>
	Purge gas Determine type and quantity	Suitable purge gas in compliance with application-specific requirements for explosion protection. - Whenever possible, low amount of dust, no oil, moisture, corrosive gases	Provide purge gas supply. Work steps, see “Purge gas supply” , page 40.
Select device components: Measuring device	Nominal length of sender/receiver unit and flange with pipe according to duct diameter, duct wall thickness with insulation Sender/receiver unit type (up to 220°C or up to 400°C) depending on gas temperature in duct Measuring probe material depending on gas composition in the duct - For corrosive gases, measuring probe made of Hastelloy	Select components according to configuration (see “Selecting the sender/receiver unit” , page 36); If necessary, plan additional measures for mounting flange with tube (see “Fitting the flange with tube” , page 45).	<input type="checkbox"/>
Select control unit	Power supply and communication options based on the intended system integration	Select components according to the Configuration Table (see “Selecting the MCUDH Ex-3K control unit” , page 37).	<input type="checkbox"/>
Plan calibration openings	Easy and safe access, no mutual interference of calibration probe and measuring system	Provide platforms or pedestals as required. Plan sufficient distance between measuring and calibration level (approx. 500 mm)	<input type="checkbox"/>
Plan the voltage supply	Supply voltage and power requirements according to Technical Data (see “Technical data” , page 118)	Plan adequate line cross-sections and fuses	<input type="checkbox"/>

5 Transport and storage

**NOTICE:****Sensitive components**

The DUSTHUNTER SP100 Ex-2K probe head contains sensitive components and must therefore be handled carefully:

- ▶ Protect the probe head from shocks.
 - ▶ Do not load the probe head.
 - ▶ Take safety precautions when transporting the device.
 - ▶ Check the components for visible damage after each transport.
-

5.1 Transport

Observe the following during device transport:

- ▶ Protect the device openings of the sender/receiver unit from weather influences and dust.
- ▶ Pack all components for transport in such a way that shocks cannot damage the components.
- ▶ Close off open electrical connections dust-tight.
- ▶ The ambient conditions specified in the Technical Data must also be observed when transporting the measuring system (see [“Technical data”, page 118](#)).

5.2 Storage

Observe the following during device storage:

- ▶ Process media residues can be hazardous to health.
- ▶ Close off open electrical connections dust-tight.
- ▶ Protect the device openings of the sender/receiver unit from weather influences and dust.
- ▶ Pack all components for storage.
- ▶ Store all components of the measuring device in a ventilated, dry, clean area.
- ▶ The ambient conditions specified in the Technical Data must also be observed when storing the measuring system (see [“Technical data”, page 118](#)).

6 Assembly

Carry out all assembly work onsite. This includes:

- ▶ Fitting the flange with tube,
- ▶ Fitting the control unit.

6.1 Assembly information

6.1.1 Proper assembly

**CAUTION:****Danger during assembly work**

Improper installation can lead to injuries.

- ▶ Observe the relevant safety regulations as well as safety notices during all assembly work.
- ▶ Only carry out assembly work on systems with hazard potential (hot or aggressive gases, higher internal duct pressure) when the system is at a standstill.
- ▶ Take suitable protection measures against possible local hazards or hazards arising from the system.

**WARNING:****Risk of injury through inadequate fastening of the device**

Inadequate fastening can cause the device or device components to become detached from the installation site and injure people if they fall down.

- ▶ Consider the device weight specifications when planning the assembly fixtures.
 - ▶ Take possible vibration loads into account when choosing the fixtures.
 - ▶ Before starting assembly, check the condition and load-bearing capacity at the installation location.
-

6.2 Preparing the measuring point

The operator is responsible for preparing the measuring point. Basis for determining the measuring point:

- Preceding project planning
- Regulations of local authorities

Responsibility of the operator

- Determining the measuring point
- Carrying out any necessary structural changes
- Determining the suitable purge gas
- Ensuring uninterrupted purge gas supply

6.3 Scope of delivery

Check the scope of delivery according to the order confirmation.

6.4 Installation sequence

Installation is carried out according to the sequence in this Section, the sender/receiver unit is not installed until commissioning.



All dimensions specified in this Section are shown in mm.



NOTICE:

Device damage due to premature installation of the measuring device on the gas duct

Unsuitable ambient conditions or the atmosphere in the measuring duct can damage the measuring system and make intended use impossible.

- ▶ The sender/receiver unit is first positioned in the duct during commissioning (see [“Fitting and connecting the sender/receiver unit”, page 62](#)).
-

6.4.1 Fitting the flange with tube

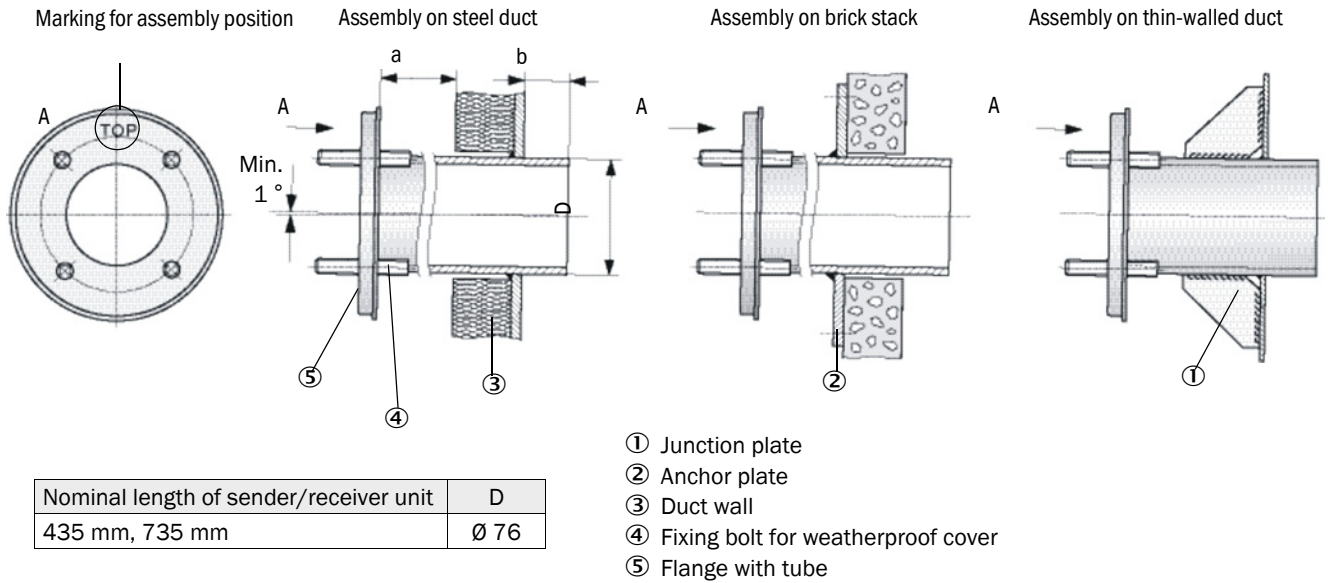

Fig. 17: Fitting the flange with tube (shown for standard version)

- Dimension a must be large enough so that a weather hood can be fitted easily when necessary (approx. 40 mm).
- Dimension b must be as large as possible under consideration of dimension a.



NOTE:

The tube length must suit the planned sender/receiver unit depending on the relation between gas temperature and nominal length (see “Flange with tube”, page 28).
 ► Do not shorten tubes.

Work to be performed

- 1 Measure the fitting location and mark the assembly location, ensure sufficient clearance to fit and remove the sender/receiver unit (see “Sender/receiver unit space requirements”, page 39).
- 2 Remove thermal insulation (when fitted).
- 3 Cut suitable openings in the duct wall; bore large enough holes in brick or concrete stacks (flange tube diameter).



NOTE:

► Do not let separated pieces fall into the duct.

- 4 Insert the flange with tube in the opening slanting slightly downwards (1 to 3°) so that the “Top” marking points upwards and any condensate that may collect in the duct can drain off.
- 5 Weld the flange with tube on using an anchor plate for brick or concrete stacks, insert junction plates for thin-walled ducts.
- 6 Close off the flange opening with a blind flange after fitting (see “Fastening technology”, page 126) to prevent gas escaping.

6.4.1.1 High-temperature version



High-temperature version

- Fitting on a steel duct, brick stack and on a thin-walled duct is the same as for the standard version.



NOTICE:
High-temperature version

Temperature damage can occur on the sender/receiver unit when fitted without a flange with tube.

- ▶ The flange inner diameter must be 70 mm otherwise correct purging is not possible.
- ▶ Only fit the measuring probe in the duct as far as necessary (see above measure 40 mm) to avoid temperature damage.

Fitting the measuring probe NL 435 mm

- ① Flange with tube
- ② Duct
- ③ Purge gas

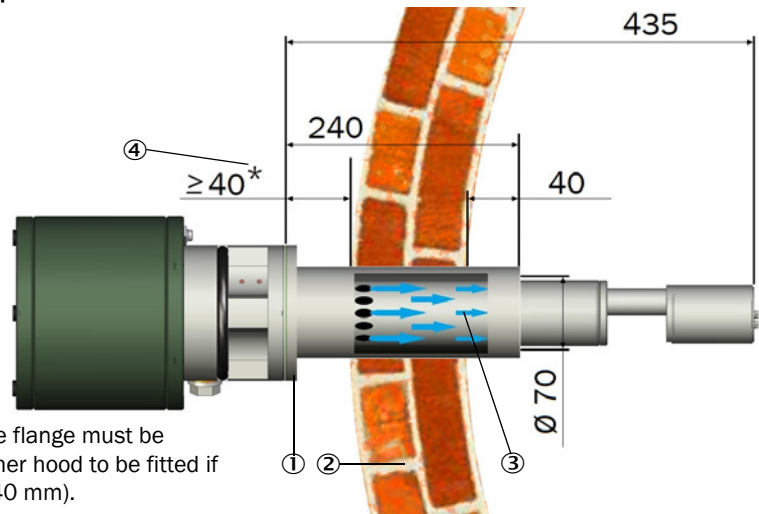

- ④ * The distance to the flange must be sufficient for a weather hood to be fitted if necessary (at least 40 mm).

Fig. 18: Fitting the flange with tube (all dimensions in mm)
Shown for high-temperature version, nominal length 435 mm

Fitting the measuring probe NL 735 mm

- ① Flange with tube
- ② Duct
- ③ Purge gas

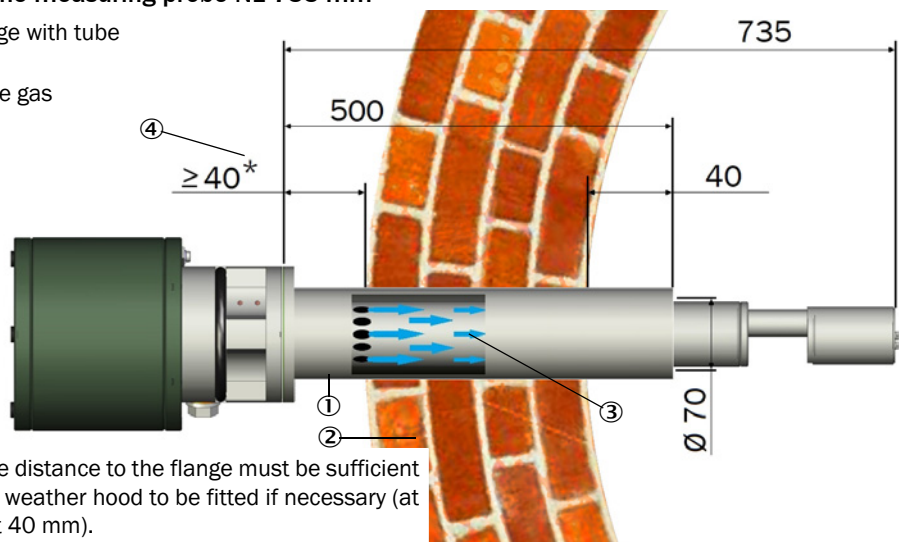

- ④ * The distance to the flange must be sufficient for a weather hood to be fitted if necessary (at least 40 mm).

Fig. 19: Fitting the flange with tube (all dimensions in mm)
Shown for high-temperature version, nominal length 735 mm

6.4.1.2 *Fitting a weather hood***Weather hood for sender/receiver unit**

This weather hood serves to protect the sender/receiver unit. It comprises a base plate and a protective hood.

A special weather hood is available for explosion-proof areas. Other compatible weather hoods must not be used in explosion-proof areas (see “Weather protection”, page 126).

Assembly:

- 1 Push base plate (2) on flange with tube (5), slot onto threaded bolts (4) of the duct-side surface of the flange plate and screw on (see “Fitting the weather hood for the sender/receiver unit”, page 47).
- 2 Connect the potential equalization.

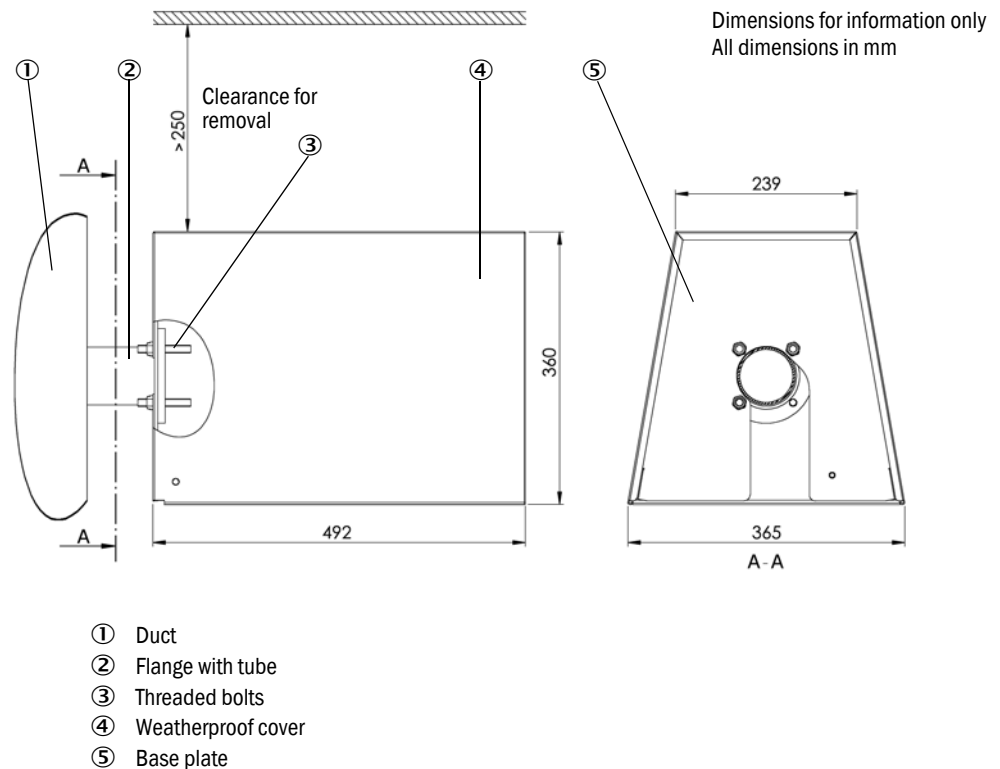

Fig. 20: Fitting the weather hood for the sender/receiver unit

6.4.2 Fitting the MCUDH Ex-3K control unit

Fit the MCUDH Ex-3K control unit in a protected location that is easily accessible (see [“MCUDH Ex-3K control unit space requirements”, page 39](#)). Observe the following points during fitting:

- The MCUDH Ex-3K control unit may only be used in Ex-areas in accordance with the specifications (see [“Application illustration DUSTHUNTER SP100 Ex-2K”, page 33](#)).
- Maintain the ambient temperature range in accordance with the Technical Data under consideration of possible radiant heat (shield when necessary).
- Protect from direct sunlight.
- Whenever possible, choose an assembly location with minimum vibrations; dampen any vibrations when necessary.
- Provide sufficient clearance for lines and opening the door.
- When opening the enclosure door, take suitable precautions to prevent dust from entering.

The control unit can be mounted up to 1000 m away from the sender/receiver unit when using a separate 24 V power supply provided by the customer and using suitable lines (see [“Information on connection lines”, page 52](#)).

For outdoor installation, it is necessary for the customer to provide a lockable weather hood.

7 Electrical installation



NOTE:

Check device suitability before installation.

- ▶ Before installation, check that the type code and type plate match the intended application.

All assembly work previously described must be completed (as far as applicable) before starting installation work.

Carry out all installation work onsite unless otherwise explicitly agreed with Endress+Hauser or authorized representatives. This includes laying and connecting the power supply and signal lines, installing switches and power fuses, and connecting the purge gas supply.



- Plan adequate line cross-sections (see “[Information on connection lines](#)”, page 52).
- Line ends with plugs to connect the sender/receiver unit must have sufficient free length.
- The potential equalization line of the sender/receiver unit must be flexible enough to allow the sender/receiver to be removed from the duct with the potential equalization connected.

7.1 Electrical installation safety information



WARNING:

Endangerment of electrical safety during installation and maintenance work when the power supply is not switched off.

An electrical accident can occur during installation and maintenance work when the power supply to the device and lines is not switched off using a power isolating switch or circuit breaker.

- ▶ Before starting work on the device, ensure the power supply can be switched off using a power isolating switch or circuit breaker.
- ▶ Make sure the power isolating switch is easily accessible.
- ▶ An additional disconnecting device is mandatory when the power isolating switch cannot be accessed or only with difficulty after installation.
- ▶ The power supply may only be activated again after the work, or for test purposes, by personnel carrying out the work under consideration of valid safety regulations.



WARNING:

Endangerment of electrical safety through power line with incorrect rating

Electrical accidents can occur when the specifications for replacement of power lines have not been adequately observed for the line.

- ▶ Always observe the exact specifications in the Operating Instructions when replacing the power line (see “[Technical data](#)”, page 118).

7.2 Connection overview

Pay attention to zone separation when installing and connecting device components (see [“Application illustration DUSTHUNTER SP100 Ex-2K”, page 33](#)).

Connecting is done in three main steps:

- 1 Before connection work, establish potential equalization of devices to be connected.
- 2 Before commissioning: Make the connections for the device components other than the sender/receiver unit.
- 3 During commissioning: Establish the connections still required on the sender/receiver unit at the measuring point.

7.2.1 Connection overview

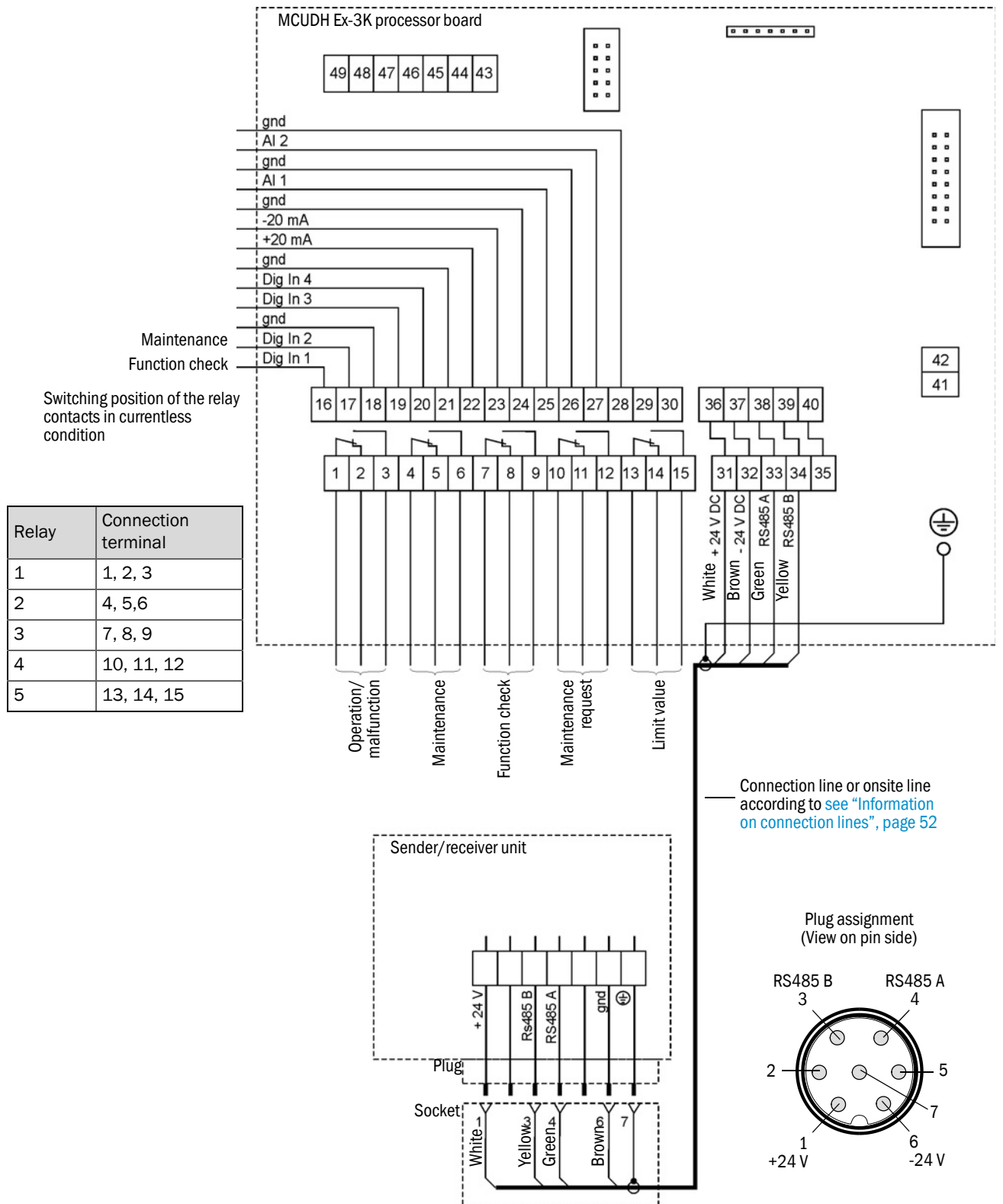

Fig. 21: Connection overview

7.3 Information on connection lines

**DANGER:****Risk of explosion through unsuitable screw fittings and electric lines**

- ▶ Use only suitable cables (according to valid standard) with matching outside diameter.
- ▶ Protect lines against electrostatic charges.
- ▶ Only open those line inlets to be used for the installation. Keep the screw plugs.
- ▶ Refit the original screw plugs when a line inlet has to be closed again.

Line requirements in the safe area (no explosion protection zone)

For the signal lines with low voltage limits, only use shielded lines with twisted pairs (e.g., UNITRONIC LiYCY (TP) Li2YCY 2 x 2 x 0.5 mm² from LAPPKabel; 1 pair of wires for RS 485, 1 pair of wires for power supply; not suitable for underground laying). Lines with other designations but equivalent construction and comparable or higher electrical properties are permissible.

Line requirements in the explosion protection zone

- The documentation for zone division according EN 60079-10 must be available.
- The lines to be used must be checked for suitability for the application area.
- After installation, an initial test of the device and the system according to EN 60079-17 must be performed.
- Potential equalization and line connections must fulfill the requirements according to EN 60079-14.
- Lines which are especially endangered by thermal, mechanical or chemical stress, must be protected, e.g., by laying in protective tubes open at both ends.
- For lines not protected against smoldering, the fire behavior must be verified according to IEC 60332-1.
- The cross-section of each individual wire must not be smaller than 0.5 mm².
- When selecting the lines, the respective clamping range of the line duct described here must be observed. If you need more than one line duct or line ducts with different diameters, a set can be found in the spare parts (see [“Spare parts, MCUDH Ex-3K control unit”, page 125](#)).
- The inserted lines must be routed to the designated terminals by the shortest possible route and fixed inside the enclosure in order to maintain the air and creepage distances of the existing circuits.
- Ex cable glands must be suitable for the intended cable type (e.g., lines with or without shield).
- Protect the wire ends with connector sleeves against fraying.
- Replace unused line inlets with the enclosed Ex-e sealing plugs.
- Unused wires must be connected with a ground line (ground potential) or secured so that a short circuit with other conductive parts is excluded.
- Torque for tightening the line glands with sealing plugs: 5 Nm, for line glands with inserted line: 10 Nm.

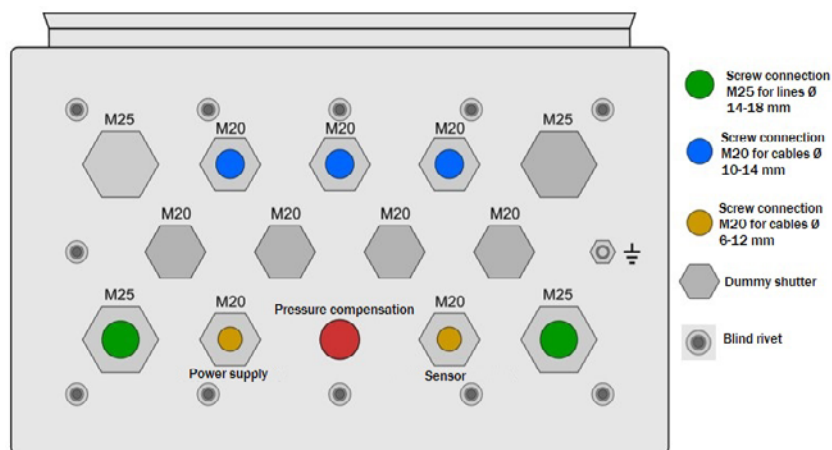

Fig. 22: Line glands MCUDH-Ex 3K

7.4 Connecting the sender/receiver unit

Connecting the sender/receiver unit is covered in the Section on the control unit, the sender/receiver unit is only positioned in the duct during commissioning (see “Fitting and connecting the sender/receiver unit”, page 62).

7.5 Connecting the control unit



WARNING:

Connect potential equalization when working on the measuring system

Potential differences can lead to explosions.

- ▶ Connect the potential equalization as first task during assembly and as last task during disassembly.

7.5.1 MCUDH Ex-3K component layout

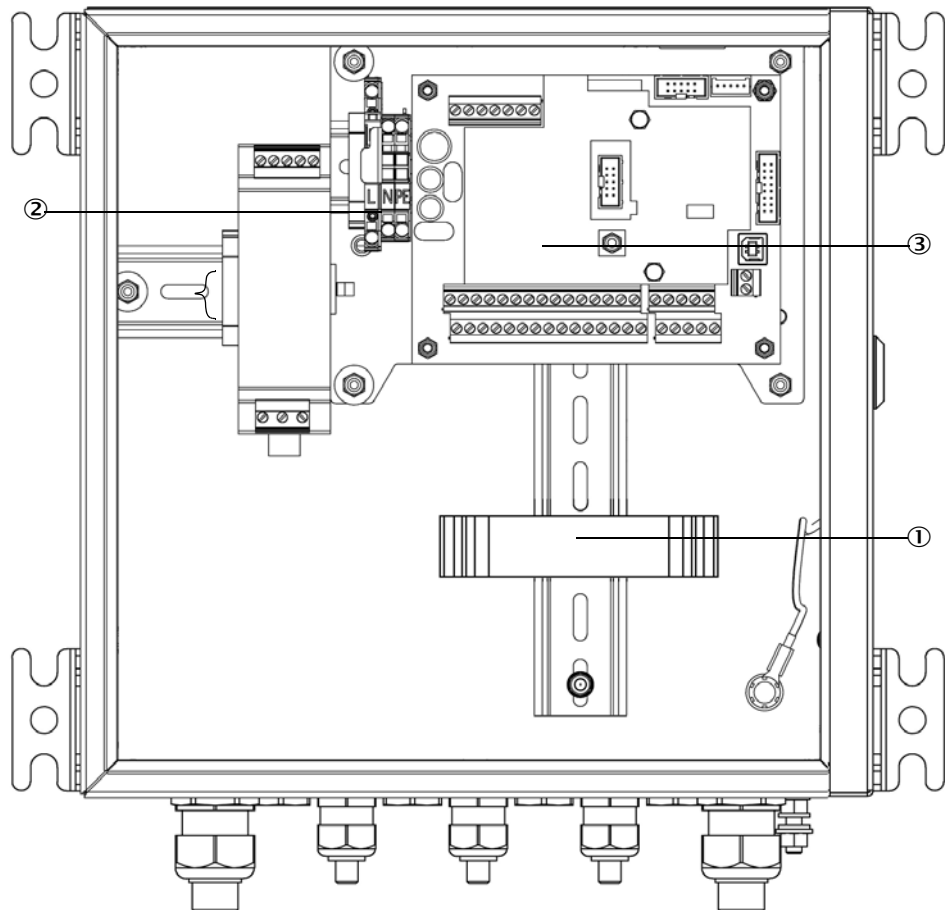

- ① Optional Interface module
- ② Terminals for power connection
- ③ Processor board

Fig. 23: Component layout in the explosion-proof MCUDH Ex-3K

7.5.2 Work to be done

- ▶ Connect the connection line: see “Connection overview”, page 51.

+i NOTE:
Alternative connection options to the connecting line with Ex-Plug-Connector on request.

- ▶ Connect lines for status signals (operation/malfunction, maintenance, function check, maintenance request, limit value), analog output, analog and digital inputs according to requirements (see “Connection overview”, page 51 and see “Connecting interfaces”, page 59).
- ▶ Connect power line to terminals L1, N, PE of the control unit (see “Connecting the control unit”, page 54).
- ▶ Close off unused line ducts with dummy plugs.

+i NOTE:
If more connecting lines are to be inserted than initially planned, a set with line ducts is available for the MCUDH Ex-3K control unit (see “Spare parts, MCUDH Ex-3K control unit”, page 125).

! NOTICE:
Faulty wiring can damage the measuring system

- ▶ Be sure to check the potential equalization of the devices and the wiring before switching the supply voltage on.
- ▶ Only modify wiring when disconnected from the power supply and potential-free.

7.5.3 MCUDHEx-3K processor board connections

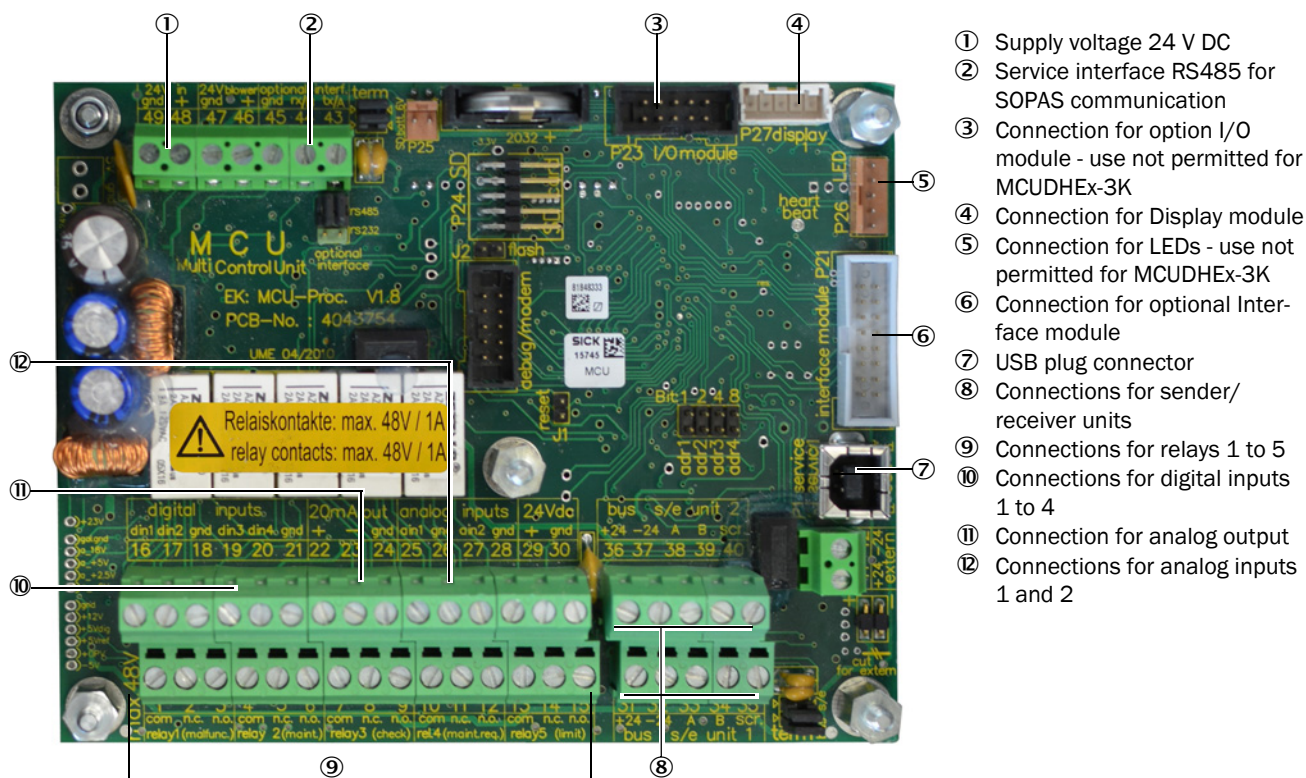
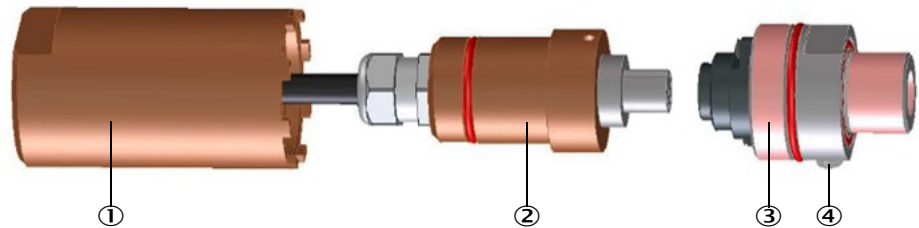

Fig. 24: MCUDH Ex-3K processor board connections

7.5.4 Connecting the connection line to the control unit

The Ex-Plug-Connector (see “Connection line with Ex-Plug-Connector”, page 29) may only be connected to, or disconnected from, the DUSTHUNTER SP100 Ex-2K when de-energized. The connector plug is firmly mounted on the DUSTHUNTER SP100 Ex-2K. The socket is attached to the connector plug, the plug connection is reverse polarity protected. Then the coupling sleeve is opened to secure the socket on the connector plug. The locking screw on the connection plug must be unscrewed far enough so that the toothed rim of the coupling sleeve comes behind the screw head. After attaching the coupling sleeve to the connector plug, the coupling sleeve must be fixed with the locking screw, if necessary the coupling sleeve must be screwed back a little bit for this purpose.



- ① Coupling sleeve
- ② Socket
- ③ Connection plug
- ④ Securing screw

Fig. 25: Ex-Plug-Connector connection

- ① [-] 24 V
- ②
- ③ RS 485 A
- ④ RS 485 B
- ⑤
- ⑥ [+] 24 V
- ⑦ Shielding

see “Connection overview”, page 51

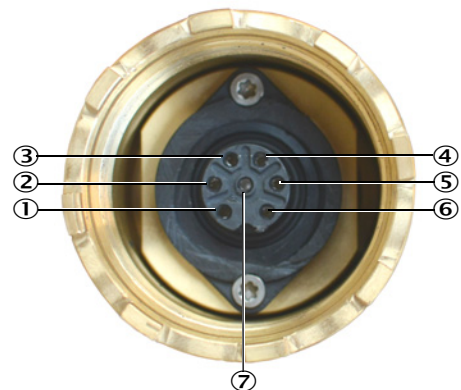

Fig. 26: Ex-Plug-Connector pin assignment

7.6 Installing the purge gas supply

Purge gas hose



WARNING:

Risk of explosion through electrostatic charges

- ▶ An antistatic purge gas hose must be used within the Ex-protection zone.

Purge gas supply connection

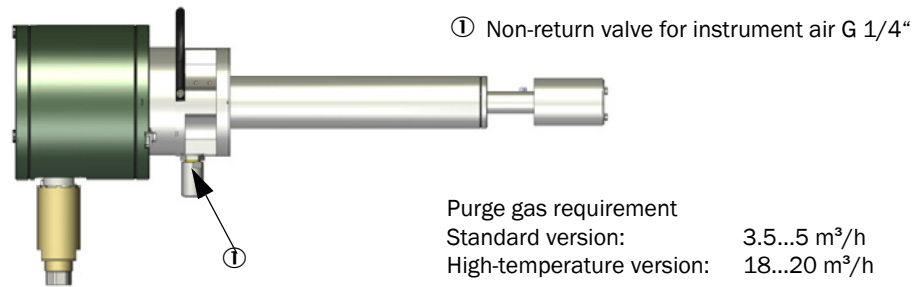

Purge gas requirement
 Standard version: 3.5...5 m³/h
 High-temperature version: 18...20 m³/h

Fig. 27: Purge gas supply connection with sender/receiver unit

For the requirements on the purge gas to be provided onsite see “Purge gas supply”, page 40.

- ▶ Provide purge gas supply meeting the requirements.
- ▶ Connect purge gas to the thread of the non-return valve and check the flow direction is correct.

Purge gas supply	Activity
Type and quantity determined by the operator	Connect the purge gas to the thread of the non-return valve (see Fig. 27, page 57).

7.7 Connecting Remote Display 100

The Remote Display 100 is not suitable for use in Ex-areas. The data line and, if necessary, the power supply must be routed to the safe area where the Remote Display 100 is to be installed.

7.7.1 Connection to the MCUDH Ex-3K control unit

Electrical connection [see “Connection overview”, page 51](#)

- Electrical connection of the Remote Display 100 without own power supply unit:
 - 24 V supply: Connection terminals 36 and 37 (or equivalent)
 - Signals: Connection terminals 38 and 39 (or equivalent)
- Electrical connection of Remote Display 100 with own power supply unit
 - Signals: Connection terminals 38 and 39 (or equivalent)

7.7.2 Connection to the Remote Display 100

Version without power supply unit

- ▶ Connect the connection line to the measuring and control unit (4-wire, twisted pair, with shield) to the connections in the control unit and the module of the Remote Display 100.

Version with integrated power supply unit:

- ▶ Connect the 2-core line (twisted pair, with shielding) to the RS485 A/B connections and shielding in the control unit and Remote Display 100,
- ▶ Connect the 3-wire power cable with sufficient cross-section to the on-site power supply and the corresponding connection terminals in the Remote Display 100.

7.8 Connecting interfaces

7.8.1 Interface module (option) of the MCUDH Ex-3K

The optional RS485 (Modbus ASCII/RTU) interface module is to be plugged onto the top-hat rail in the control unit (see “MCUDH Ex-3K component layout”, page 54) and connected to the corresponding connection on the processor board with the ribbon cable via plug connector (see “MCUDHEx-3K processor board connections”, page 55).

The module offers the possibility to connect another optional Ethernet CoLa-B or Ethernet Modbus® TCP interface module (see “Options for MCUDH Ex-3K control unit”, page 127) via a RS485 signal line up to 1000 m long, outside the Ex-area, for example in a control room. These two interface options are not intended for use in Ex-areas. Furthermore the RS485 signal line can be used directly.

To use the USB service interface, we recommend using the Sopas Service Kit (2097408) and the appropriate adapter plug (6075779).

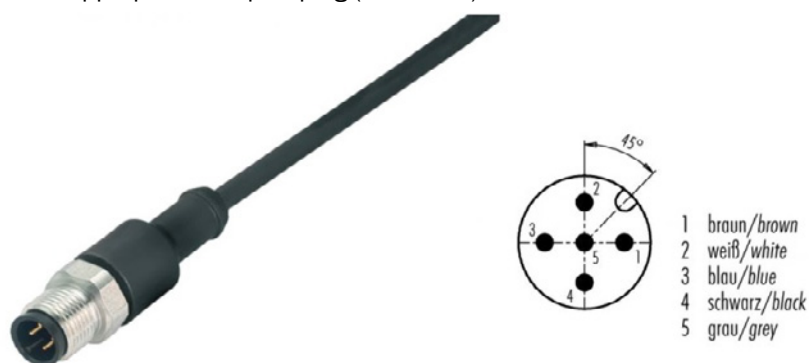
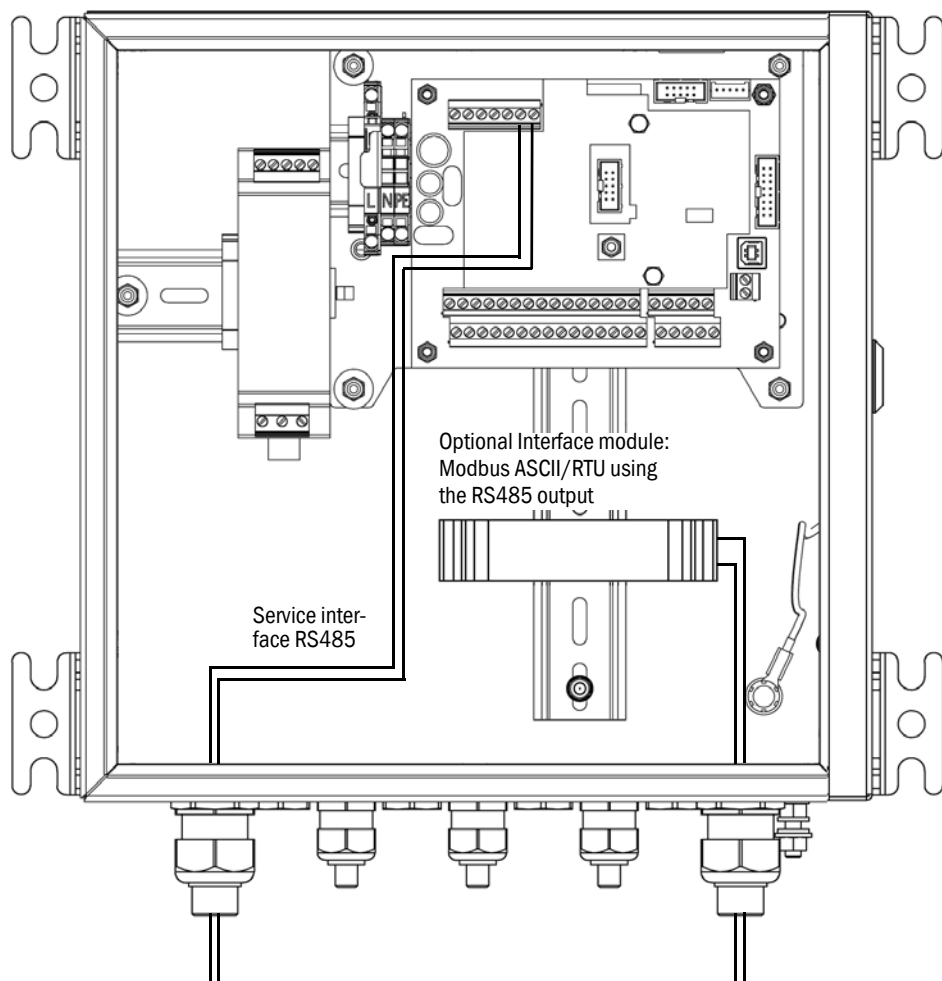

Fig. 28: Adapter plug (6075779) with connection diagram



- | | | |
|--|-------------------------------------|--|
| <p>Option 1 - Sopas via USB:
Sopas Service Kit (2097408)
and plug adapter (6075779)</p> <p>Option 2 - Sopas via Interface module with
separate 24 V supply:
Ethernet CoLa-B Module(2069666)
and power supply unit 24 V (6059059)</p> | <p>Safe area
Remote modules</p> | <p>Option 1 - Sopas via USB:
Sopas Service Kit (2097408)
and plug adapter (6075779)</p> <p>Option 2 - Sopas via Interface module with
separate 24 V supply:
Ethernet CoLa-B Module (2069666)
and power supply unit 24 V (6059059)</p> <p>Option 3 - Interface module with separate
24 V supply:
Ethernet Modbus TCP/IP Module
(2069664)
and power supply unit 24 V (6059059)</p> |
|--|-------------------------------------|--|

Fig. 29: Interface options MCUDH Ex-3K based on using the RS485 output

8 Commissioning

8.1 Safety information on commissioning

**NOTICE:**

Device damage possible due to an unprofessionally executed electrical installation.
▶ The manufacturer recommends having the initial commissioning carried out by Endress+Hauser Service.

The explosion protection regulations must be observed during commissioning:

- Do not remove, add or change any components on the sender/receiver unit unless described and specified in the official manufacturer information, otherwise the approval for use in potentially explosive atmospheres becomes void.
- Follow the sequence of the commissioning procedure described in this Section.
- Adhere to the prescribed maintenance intervals (see [“Maintenance plan”, page 91](#)).
- Do not insert or remove the power supply plug on the sender/receiver unit when under voltage.
- System components without Ex marking must not be used in potentially explosive atmospheres.
- Ex atmospheres
 - Observe regulations for transport in Ex atmospheres, e.g. no transport of packaging materials in Ex atmospheres.
 - Do not perform installation work in Ex atmospheres.
Commissioning, decommissioning and cleaning may only be performed when it is verified that no explosive media are present (verification by gas detector).
 - Do not open or close the sender/receiver unit enclosure in Ex atmospheres.
- Ex protection zone
 - Only employ trained personnel in the Ex protection zone.
 - Only use suitable tools for the Ex protection zone.
 - Observe behavior rules to prevent sparks.
 - Only work that does not affect ignition protection is allowed.

8.2 Requirements for commissioning

The following requirements must be met before starting commissioning:

- All specifications are met in accordance with the project planning.
- All the work in the Assembly Section has been completed and checked.
- Electrical installation is completed and checked.
- Measuring point has been checked for free access without hazards.

8.3 Inserting and switching on

8.3.1 Adapt the sender/receiver unit to the duct geometry

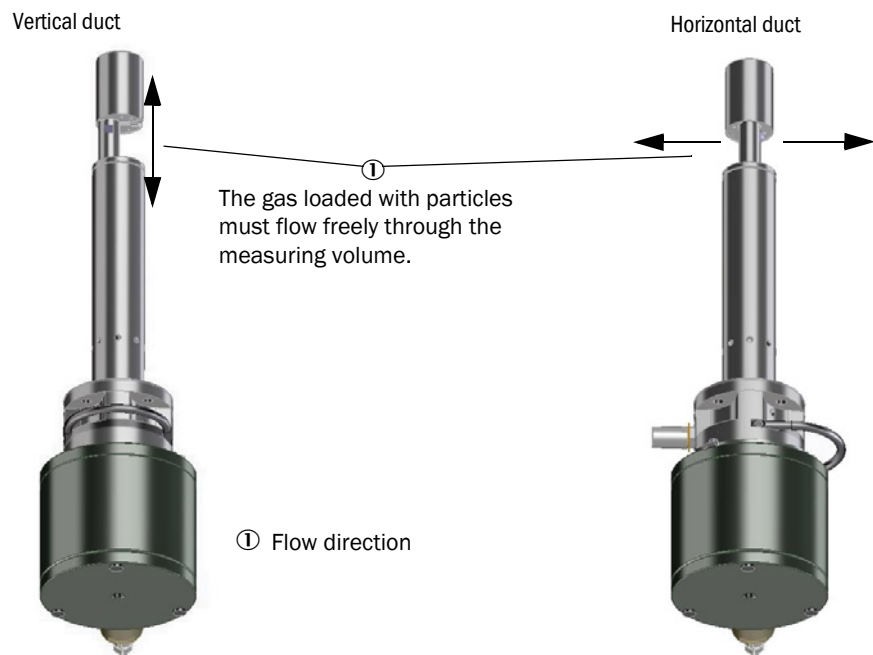

Fig. 30: Measuring probe alignment

The sender/receiver unit is delivered for vertical fitting as standard when the duct direction (horizontal or vertical) is not specified in the order. Rotate the sender/receiver unit 90° when fitting on a horizontal duct (see [“Adjusting the duct geometry”, page 100](#)).

8.3.2 Fitting and connecting the sender/receiver unit



WARNING:

Risk of poisoning by exhaust gases

When the sender/receiver unit is installed in potentially explosion-hazardous areas, toxic or aggressive gases or dusts may escape and cause injury through inhalation or contact.

- ▶ In case of potential danger, only install the sender/receiver unit on the duct when the system is at a standstill.

The sender/receiver unit is already connected to the purge gas supply (see [“Installing the purge gas supply”, page 57](#)) and connected to the control unit with the connecting line (see [“Connecting the connection line to the control unit”, page 56](#)), now the steps for insertion in the duct follow:

- 1 Connect a flexible potential equalization line that allows the sender/receiver unit to be removed from the duct when connected.
- 2 Activate purge gas supply.
- 3 Push the sender/receiver unit with the correct alignment (see [“Adapt the sender/receiver unit to the duct geometry”, page 62](#)) into the flange with tube. Do not forget the seal and fasten it with the mounting kit (see [“Fastening technology”, page 126](#)). Make sure the probe head is not damaged during fitting.
- 4 Switch the supply voltage on.

8.3.3 Start measuring operation

Set the measuring system to “Maintenance” mode to enter or modify parameters.

To do so, cancel “Maintenance”: Deselect “Maintenance Sensor”.

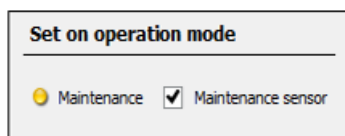

Fig. 31: SOPAS ET menu: MCU/Maintenance/Maintenance

Standard commissioning is now completed.

8.4 Recognizing the safe operating state

The system is in proper operation when:

- A system check has been carried out according to the Maintenance plan before commissioning and in running operation.
- Only the green status indicator on the control unit lights up and the operating status “Measuring operation” is shown on the display.

Recognizing malfunctions

Any deviation from normal operation must be regarded as a serious indication of a functional impairment or unsafe operating state. These are, amongst others:

- Warnings displayed (e.g., high contamination)
- Significant drifts in measured results
- Increased power consumption
- Higher temperatures of system components
- Monitoring devices triggering
- Smells or smoke emission

Necessary insulation

The thermal insulation is an explosion protection measure to be subjected to special examination when gas temperatures in the duct are higher than the surface temperature allowed by the selected temperature class. Observe the following during this examination:

- Apart from the duct surface, other parts (e.g. flange tube and flange) that can be subjected to prohibited high temperatures through thermal conduction are to be included in the insulation or the thermal conduction prevented
- The operator must ensure that suitable insulation reduces the heat radiation so that the pressure-resistant enclosure temperature is below 85 °C and therefore remains below the temperature for the temperature protection class. The operator must take into consideration that the device-internal warming can be up to 2K
- The maximum ambient temperature of 60 °C must be observed during operation ([see “Technical data”, page 118](#))

Electrical connection

Ensure the device can be switched off with a power isolating switch or circuit breaker in accordance with EN 61010-1.

9 Configuring

9.1 Prerequisites

Prerequisite for the work described in the following is completion of assembly, installation and commissioning as described in Sections 6, 7 and 8.

This Section covers customer-specific configuring according to the respective requirements.

To achieve exact measurement when using the measuring system for continuous measurement of the dust content, the measuring system must first be calibrated using a gravimetric comparison measurement (see [“Calibration for dust concentration measurement”, page 77](#)).

This Section deals with configuring via SOPAS ET, alternatively, configuration can be performed directly on the display of the control unit (see [“Configuring on the control unit display”, page 87](#)).

9.2 SOPAS ET

9.2.1 Install SOPAS ET

- Install SOPAS ET on a computer
- Start SOPAS ET
- Follow the SOPAS ET installation instructions

9.2.2 Password for SOPAS ET menus

Certain device functions are first accessible after a password has been entered.

Table 11: SOPAS ET user levels

User level		Access rights
0	Operator	Displays measured values and system states No password required.
1	Authorized operator	Displays, inquiries as well as parameters required for commissioning or adjustment to customer-specific demands and diagnosis. Preset password: sickoptic

9.2.3 Changing the password for SOPAS ET menus

To change the password for a user level, the operator must be logged in to SOPAS ET at the appropriate level. To do this, start SOPAS ET and add a connected device to the project. Open the device window by double-clicking on the connected device and log in to the user level for which the password is to be changed. In the command bar, a menu is named after the connected device, click on the “Change password” setting in this pull-down menu.

9.3 Connecting to MCUDH Ex-3K control unit

9.3.1 Connect to the MCUDH Ex-3K control unit via the Service interface

Recommended procedure:

- 1 Connect the RS485 line to the MCUDH Ex-3K control unit Service interface (see [“Interface module \(option\) of the MCUDH Ex-3K”, page 59](#)).
- 2 Connect the RS485-USB converter to the RS485 line, e.g. the adapter cable “SOPAS Service Kit” which is available in the MCUDH Ex-3K accessories (see [“Options for MCUDH Ex-3K control unit”, page 127](#)).
- 3 Connect the USB connection with the computer.
- 4 Switch control unit on.
- 5 Start SOPAS ET.
- 6 Select “Search settings”.
- 7 “Device family oriented search”
- 8 Click on the MCU (DH) control unit.
- 9 Make the settings:
 - Ethernet communication (always clicked)
 - USB communication (always clicked)
 - Serial communication: Click
- 10 Do not specify IP addresses.
- 11 A list of COM ports appears.
Specify the COM port of the DUSTHUNTER.
If you do not know the COM port: see [“Finding the DUSTHUNTER COM port”, page 81](#).
- 12 Enter a name for this search if you want to save it.
- 13 Click “Finish”.

9.3.2 Connect to the MCUDH Ex-3K control unit via Ethernet (option)



To connect to the measuring system via Ethernet, the integrated interface module Modbus ASCII/RTU must be installed in the MCUDH Ex-3K control unit (see [“Interface module \(option\) of the MCUDH Ex-3K”, page 59](#)). An RS485 line can be used to connect a remote Modbus TCP/IP or Ethernet type 2 interface module (see [“Options for MCUDH Ex-3K control unit”, page 127](#)) outside the Ex-area. The connection is therefore established via RS485.

Recommended procedure:

- 1 Configure the Ethernet module via manufacturer software and note the IP address.
- 2 Connect the laptop/PC with the Ethernet module.
- 3 Connect the switched-off control unit to the network cable (LAN).
- 4 Switch control unit on.
- 5 Start SOPAS ET.
- 6 “Search settings”
- 7 “Search by interface”
- 8 Make the settings:
 - Ethernet communication (always clicked)
 - USB communication (always clicked)
 - Serial communication: Click
- 9 Enter the noted IP address.
- 10 A list of COM ports appears.
Specify the COM port of the DUSTHUNTER.
If you do not know the COM port: see [“Finding the DUSTHUNTER COM port”, page 81](#)
- 11 Assign a name for this search.
- 12 Click “Finish”.

9.3.3 Configuring the Interface module of the MCUDH Ex-3K control unit (option)

If a control unit model that already contains the optional Interface module right from the factory is selected, this is already preconfigured. Configuring is necessary when the module is subsequently integrated. The USB service interface must not be used inside the Ex-area, therefore configuring must be carried out outside the Ex-area. The following steps are then necessary:

- 1 Select device file “MCU”, set the measuring system to “Maintenance” mode
- 2 Enter the Level 1 password (see “Password for SOPAS ET menus”, page 65).
- 3 Switch to the “Configuration / System Configuration” directory.

The installed Interface module is displayed in the field “Interface Module”. This module must be selected because only an RS485 connection is possible for the explosion-proof MCUDH Ex-3K control unit.

- 4 Installed Interface module: Select RS485.
- 5 Configure the Interface module according to requirements.

Fig. 32: SOPAS ET menu: MCU/Configuration/System Configuration

9.3.4 Connecting a remote Ethernet Interface module

The optionally integrated Interface module of the MCUDH Ex-3K control unit allows the connection of further optional Ethernet Interface modules via an up to 1000 m long RS485 connection line outside the Ex-area, based on the RS485 output of the internal Interface module (see [“Options for MCUDH Ex-3K control unit”, page 127](#)). For such a connection, the remote Ethernet module must be set to the same IPv4 network address used in the network in which the Ethernet connection is connected. The documentation supplied with the optional Ethernet module contains the necessary information. No software updates are possible via the Ethernet interface, these must be carried out via the Service interface (see [“Interface options MCUDH Ex-3K based on using the RS485 output”, page 60](#)).

9.4 System configuration

9.4.1 Application parameters

Assign the sender/receiver unit to the measuring location

The sender/receiver unit can be assigned explicitly to the respective measuring location. The following steps are then necessary:

- 1 Start the SOPAS ET program and connect to the measuring system (see “SOPAS ET”, page 65).
- 2 Select device file “DH SP100” and move it to the “Project Tree” window.

+i The respective device version connected is displayed automatically

- 3 Enter password level 1.
- 4 Set the sender/receiver unit to “Maintenance”: Click “Maintenance sensor”.

The screenshot shows two windows from the SOPAS ET software. The top window is titled "Device identification" and contains a dropdown menu with "DH" selected, an empty text field, and a "Mounting location" label followed by another empty text field. The bottom window is titled "Set on operational mode" and contains two radio buttons: "Maintenance" (which is selected) and "Maintenance sensor" (which is not selected).

Fig. 33: SOPAS ET menu: DH SP100/Maintenance/Maintenance

- 5 Select the “Configuration / Application Parameters” directory and enter the desired data in the “Mounting location” entry field under “Device Identification”.

The screenshot shows the "Device identification" window with "DH SP100" selected in the dropdown menu. The text field next to it is empty, and the "Mounting location" label is followed by an empty text field.

Fig. 34: SOPAS ET menu: DH SP100/Configuration/Application parameters (top window)

Defining regression coefficients

The “Configuration / Application parameters” directory also contains the “Calibration coefficients for calculating concentration from scattered light” window. There a set of coefficients with free choice of coefficients (Set 0) or fixed presetting (Set 1 to 3) can be selected to convert the received measurand scattered light into a dust concentration (see “Calibration for dust concentration measurement”, page 77). Select Set 0 when the application requires calibration of the measuring system or when very accurate measured values are required. Set 1 to 3 can be used when approximately correct dust concentration values are sufficient for the application.

SOPAS ET menu: DH SP100/Configuration/Application parameters (bottom window)

Table 12: Regression coefficient sets overview

Set	Regression coefficient setting	Typical application	Regression coefficients		
			Quadratic	Linear	Absolute
Set 0	Freely selectable	Any	0	1	0
Set 1	Fixed: For small particle sizes (on average 2 µm)	Usage after cloth filter units	0	0,5	0
Set 2	Fixed: For medium particle sizes (on average 5 µm)	Application after electro-filters	0	2	0
Set 3	Fixed: For large particle sizes (on average 10 µm)	Application after coarse filter (cyclone filter)	0	3	0

+i The regression coefficients in Sets 1 to 3 refer to dusts with an average density of 2.5 g/cm³, almost spherical particle structure and even dust distribution across the duct cross-section.

9.4.2 Assigning the control unit to the sender/receiver unit

+i The sender/receiver unit must be connected to the control unit.

The control unit must be set to the sender/receiver unit to be connected. A malfunction is reported in case of a mismatch. Assignment must be made after installation when the setting is not possible at the factory (e.g., when several devices are delivered at the same time or when the device is swapped later). The following steps are then necessary:

- 1 Connect the measuring system to the SOPAS ET program.
- 2 Enter the Level 1 password (see “Password for SOPAS ET menus”, page 65).
- 3 Set the sender/receiver unit to “Maintenance”: Click “Maintenance sensor”.

Fig. 35: SOPAS ET menu: MCU/Maintenance/Maintenance

- 4 Switch to the “Configuration / Application selection” directory (see “SOPAS ET menu: MCU/Configuration/Application selection”, page 72).
- 5 The basic type of the sender/receiver unit connected is displayed in the “Connected variant” window (field “Application selection”). Click “Save selection” to assign to the control unit.

Device Identification

MCU Selected variant DUSTHUNTER S (SB50, SB100,SF100,SP100) Mounting Location SICK

Application Selection

Variant DUSTHUNTER S (SB50, SB100,SF100,SP100)

Application selection

Connected variant Universal

Save selection

Supported variants
 DUSTHUNTER S (SB50, SB100,SF100,SP100)
 DUSTHUNTER T (T50,T100,T200)
 DUSTHUNTER C (C200)
 FLOWSIC100
 FLOWSIC100 - 2 Path
 DH_S+FL100 Combination
 DH_T+FL100 Combination
 DH_C+FL100 Combination
 FWE200DH
 Universal

Fig. 36: SOPAS ET menu: MCU/Configuration/Application selection

9.4.3 Factory settings

Table 13: Factory settings

Parameter		Value	
Function check		Every 8 h; output of control values (every 90 s) on standard analog output	
Analog output (AO) [mA]	Live Zero (LZ)	4	
	Measuring range end value (MBE)	20	
	Current during maintenance	0.5	
	Current by malfunction	21 (optional 1)	
Response time		60 s for all measured variables	
Measured variable	Output on AO	Value at LZ	Value at MBE
Dust concentration [mg/m ³]	1	0	200
Scattered light intensity	2		
Coefficients set (only for dust concentration)		0.00 / 1.00 / 0.00	

The steps required to modify these settings are described in the following Sections. For this purpose, the devices must be connected in SOPAS ET (see “SOPAS ET”, page 65), the Level 1 password set and the “Maintenance” mode set.

9.4.4 Determining the function check

Interval time, control value output on the analog output and the starting timepoint for automatic function check can be modified in the “Adjustment / Function Check - Automatic” directory.

Device Identification

MCU Selected variant DUSTHUNTER Mounting Location SICK

Function Check

Output duration of function control value 90 s

Function check interval 8 hours

Function Check Start Time

Hour 8 Minute 0

Fig. 37: SOPAS ET menu: MCU/Adjustment/Function Check - Automatic (example)

+i Standard values: see “Factory settings”, page 72

Table 14: Function check setting options

Entry field	Parameter	Remark
Output duration of function control value	Value in seconds	Output duration of control values.
Function check interval	Time between two check cycles	see “Function check”, page 30
Function Check Start Time	Hour	Defining a start timepoint in hours and minutes.
	Minute	

+i The value measured last is output during control value determination (see “Function check”, page 30).

9.4.5 Setting the analog outputs parameters

+i

- Standard values see “Factory settings”, page 72
- In order to output the dust concentration under standard conditions (“Conc. s.c.” (Ext)), set the parameters for the analog outputs according to see “Setting the analog inputs parameters”, page 76.

Select the “Configuration / IO Configuration / Output Parameters” directory to set the analog outputs.

Device Identification

MCU Selected variant: Mounting Location:

Analog Outputs - General Configuration

Output Error current: Error Current:

Current in maintenance: Maintenance current:

Optional Analog Output Modules

Use first analog output module:

Analog Output 1 Parameter

Value on analog output 1:

Live zero:

Output checkcycle results on the AO:

Write absolute value:

Analog Output 1 Scaling

Range low: mg/m³

Range high: mg/m³

Limiting Value

Limit value: Hysteresis type: Percent Absolute

Switch at:

Limit Switch Parameters

Limit value: mg/m³ Hysteresis: mg/m³

Fig. 38: SOPAS ET menu: MCU/Configuration/IO configuration/Output Parameters

Table 15: Analog outputs

Field	Parameter	Remark		
Analog Outputs - General configuration	Output Error current	yes	Error current is output.	
		no	Error current is not output.	
	Error Current	Value < Live Zero (LZ) or > 20 mA	mA value to be output in "Malfunction" state (error case) (size depends on connected evaluation system).	
	Current in maintenance	User defined value	A value to be defined is output during "Maintenance".	
		Last measured value	The value measured last is output during "Maintenance".	
Maintenance current	Measured value output	The current measured value is output during "Maintenance".		
	Whenever possible, value ≠ LZ	mA value to be output in "Maintenance" state.		
Optional Analog Output Modules	Use first analog output module	Inactive	Not permitted for DUSTHUNTER SP100 Ex-2K (results in error, because AO 2 and AO 3 are available by default).	
		Active	Opens the fields to set parameters for AO 2 and AO 3 (standard for DUSTHUNTER SP100 Ex-2K).	
Analog Output 1 Parameter	Value on analog output 1	Concentration a.c. (SI)	Dust concentration in operating state (based on scattered light intensity).	The selected measured variables are output on the analog output.
		Conc.s.c.dry O2 corr. (SI)	Dust concentration under standard conditions (based on scattered light intensity).	
		SI	Scattered light intensity.	
	Live zero	Zero point (0, 2 or 4 mA)	Select 2 or 4 mA to ensure being able to differentiate between measured value and switched off device or interrupted current loop.	
	Output check cycle results on the AO	Inactive	Control values (see "Function check", page 30) are not output on the analog output.	
		Active	Control values are output on the analog output.	
	Write absolute value	Inactive	Positive and negative measured values are differentiated.	
Active		The amount of the measured value is output.		
Analog Output 1 Scaling	Range low	Lower measuring range limit	Physical value at live zero.	
	Range high	Upper measuring range limit	Physical value at 20 mA.	
Limiting Value	Limit value	Concentration a.c. (SL)	Dust concentration in operating state (based on scattered light intensity).	Select the measured variable for which a limit value is monitored.
		Concentration s.c.dry O2 corr. (SL)	Dust concentration under standard conditions (based on scattered light intensity).	
		SL	Scattered light intensity.	
	Hysteresis type	Percent	Assignment of the value entered in the "Hysteresis value" field as relative or absolute value of defined limit value.	
		Absolute		
Switch at	Value exceeded	Define the switching direction.		
	Underflow			
Limit Switch Parameters	Limit value	Value	The limit value relay switches when the entered value is overflown or underflown.	
	Hysteresis	Value	Define a tolerance for resetting the limit value relay.	

9.4.6 Setting the analog inputs parameters

Select the “Configuration / I/O Configuration / Input Parameters DUSTHUNTER” directory to set the analog inputs.

Fig. 39: SOPAS ET menu: MCU/Configuration/I/O Configuration/Input Parameters

Table 16: Analog inputs

Field	Parameter	Remark
Temperature Source	Constant Value	A fixed value is used to calculate the scaled value. This parameter opens the “Temperature Constant” field to enter the scaling value in °C (° F for imperial units) or K.
	Analog Input 1	The value from an external sensor connected to analog input 1 (standard scope of delivery) is used to calculate the scaled value. This parameter opens the “Analog input 1 - Temperature” field to set the lower and upper range limit values and the Live Zero value.
Pressure Source	Constant Value	A fixed value is used to calculate the scaled value. This parameter opens the “Constant Temperature” field to enter the scaling value in mbar (= hPa).
	Analog Input 2	The value from an external sensor connected to analog input 2 (standard scope of delivery) is used to calculate the scaled value. This parameter opens the “Analog input 2 - Pressure” field to set the lower and upper range limit values and the Live Zero value.
Moisture Source	Constant Value	A fixed value is used to calculate the scaled value. This parameter opens the “Constant Moisture” field to enter the scaling value in %.
	Analog Input 3	The value from an external sensor connected to analog input 3 (optional module required) is used to calculate the scaled value. This parameter opens the “Analog input 3 - Moisture” field to set the lower and upper range limit values and the Live Zero value.
Oxygen Source	Constant Value	A fixed value is used to calculate the scaled value. This parameter opens the “Constant Oxygen” field to enter the scaling value in %.
	Analog Input 4	The value from an external sensor connected to analog input 4 (optional module required) is used to calculate the scaled value. This parameter opens the “Analog input 4 - Oxygen” field to set the lower and upper range limit values and the Live Zero value.

9.4.7 Setting the response time

Select the “Configuration / Value Damping” directory to set the damping time (response time).

Device Identification		
MCU	Selected variant	DUSTHUNTER
	Mounting Location	SICK
Value Damping Time		
Damping time for Sensor 1		60 sec

Fig. 40: SOPAS ET menu: MCU/Configuration/Value Damping

Erratic increases in measured values can be “calmed” with the damping time, a longer damping time reduces output signal fluctuations.

Table 17: Damping time (response time)

Field	Parameter	Remark
Damping time Sensor 1	Value in s	Damping time for the measured variable Setting range 1 ... 600 s

9.4.8 Calibration for dust concentration measurement

For exact dust concentration measurement, the relation between the primary measured variable “Scattered light intensity” and the actual dust concentration in the duct must be established. To do this, the dust concentration must be determined based on a comparative gravimetric measurement according to DIN EN 13284-1 and set in relation to the values measured at the same time by the measuring system.



NOTE:

The performance of a comparative gravimetric measurement requires special equipment and knowledge, which are described in more detail in DIN EN 13284 and others.

Steps to be carried out

- 1 Select device file “MCU”, set the measuring system to “Maintenance” mode
- 2 Enter the Level 1 password (see “Password for SOPAS ET menus”, page 65).
- 3 Select the “Configuration / IO Configuration / Output Parameter” directory (see “SOPAS ET menu: MCU/Configuration/IO configuration/Output Parameters”, page 74) and assign the “Scattered light intensity” measured variable to one of the three analog outputs available.
- 4 Estimate the measuring range required for the dust concentration in operational state and enter this in the “Analog output 1 (2/3) Scaling” field assigned to the selected analog output assigned to the scattered light intensity.
- 5 Deactivate the “Maintenance” status.
- 6 Carry out the gravimetric comparison measurement according to DIN EN 13284-1.
- 7 Determine regression coefficients from the mA values of the analog output for “Scattered light intensity” and the actual dust concentrations measured gravimetrically.

$$c = K2 \cdot I_{out}^2 + K1 \cdot I_{out} + K0 \quad (1)$$

c: Dust concentration in mg/m³
 K2, K1, K0: Regression coefficients of the function $c = f(I_{out})$
 I_{out}: Current output value in mA

$$I_{out} = LZ + SL \cdot \frac{20mA - LZ}{MBE} \quad (2)$$

SL: Measured scattered light intensity
 LZ: Live Zero
 MBE: Defined upper range limit value
 (value entered for 20 mA;
 normally 2.5 x fixed limit value)

8 Enter the regression coefficients

There are two options:

- Direct input of K2, K1, K0 in a measured value computer.



NOTE:

In this case, the regression coefficients set in the sender/receiver unit and the measuring range set in the control unit may no longer be changed anymore as this will impair the calculation of the dust concentration from the scattered light values. The dust concentration is displayed in mg/m³ on the LC display of the control unit as an uncalibrated value.

- Use the regression function of the measuring system (use without measured value computer).

In this case, the correlation to the scattered light intensity has to be determined. To do this, calculate the regression coefficients cc2, cc1, cc0 to be entered in the measuring system from K2, K1, K0.

$$c = cc2 \cdot SL^2 + cc1 \cdot SL + cc0 \quad (3)$$

Using (2) in (1), the result is as follows:

$$c = K2 \cdot \left(LZ + SL \cdot \frac{20mA - LZ}{MBE} \right)^2 + K1 \cdot \left(LZ + SL \cdot \frac{20mA - LZ}{MBE} \right) + K0$$

Using (3), the result is as follows:

$$\begin{aligned} cc0 &= K2 \cdot LZ^2 + K1 \cdot LZ + K0 \\ cc1 &= (2 \cdot K2 \cdot LZ + K1) \cdot \left(\frac{20mA - LZ}{MBE} \right) \\ cc2 &= K2 \cdot \left(\frac{20mA - LZ}{MBE} \right)^2 \end{aligned}$$

9 Now enter the regression coefficients cc2, cc1 and cc0 determined in directory "Configuration/Application parameters" (see "Defining regression coefficients", page 71) (set sender/receiver unit to "Maintenance" state and enter the Level 1 password).

10 After entering, set the sender/receiver unit to "Measurement" mode again.

9.4.9 Changing display settings

To change factory settings, connect SOPAS ET to the control unit (see “Connecting the control unit”, page 54), enter the level 1 password and select the “Parameter settings/ Display settings” directory.

Device Identification

MCU Selected variant DUSTHUNTER Mounting Location SICK

Common Display Settings

Display language English Display Unit System metric

Overview Screen Settings

Bar 1	Sensor 1	Value Value 1	Use AO scaling <input type="checkbox"/>	Range low -100	Range high 1000
Bar 2	MCU	Value Value 1	Use AO scaling <input type="checkbox"/>	Range low -100	Range high 1000
Bar 3	Not Used	Value Value 1	Use AO scaling <input type="checkbox"/>	Range low -100	Range high 1000
Bar 4	Not Used	Value Value 1	Use AO scaling <input type="checkbox"/>	Range low -100	Range high 1000
Bar 5	Not Used	Value Value 1	Use AO scaling <input type="checkbox"/>	Range low -100	Range high 1000
Bar 6	Not Used	Value Value 1	Use AO scaling <input type="checkbox"/>	Range low -100	Range high 1000
Bar 7	Not Used	Value Value 1	Use AO scaling <input type="checkbox"/>	Range low -100	Range high 1000
Bar 8	Not Used	Value Value 1	Use AO scaling <input type="checkbox"/>	Range low -100	Range high 1000

Measured Value Description

<p>Dusthunter 5 Value 1 = not used Value 2 = Concentration a.c. (SL) Value 3 = not used Value 4 = not used Value 5 = not used Value 6 = not used Value 7 = Scattered Light Value 8 = not used</p>	<p>Calculated values (MCU) Value 1 = Concentration s.c. dry O2 corr. (SL) Value 2 = not used Value 3 = not used Value 4 = not used Value 5 = Temperature Value 6 = Pressure Value 7 = Moisture Value 8 = Oxygen</p>
--	--

Security settings

Authorized operator 1234 Idle time 30 Minutes

Fig. 41: SOPAS ET menu: MCU/Configuration/Display Settings

Table 18: Display settings

Window	Entry field	Significance
Common Display Settings	Display language	Language version shown on the LC display.
	Display Unit System	Unit of measurement system used in displays.
Overview Screen Settings	Bars 1 to 8	Number of the measured value for the measured value bar of the graphic display (see “Assignment of the measured values in the control unit” , page 80).
	Value	Measured value index for the respective measured value bar.
	Use AO scaling	When activated, the measured value bar is scaled to the associated analog output. If this selection field is not activated, define the limit values separately.
	Range low	Values for the separate scaling of the measured value bar, independent of the analog output.
	Range high	
Security settings	Authorized operator	Password input for the Display menu operating level “Authorized Operator” (Default: 1234).
	Idle time	Time until user level “Authorized Operator” is automatically switched off again.

Settings overview screen

Table 19: Assignment of the measured values in the control unit

Measured value	Assignment
Value 1 - Sensor	Not used
Value 2 - Sensor	Concentration a.c. (SL)
Value 3 - Sensor	Not used
Value 4 - Sensor	Not used
Value 5 - Sensor	Not used
Value 6 - Sensor	Not used
Value 7 - Sensor	Scattered light
Value 8 - Sensor	Not used
Value 1 - Control unit (MCU)	Concentration s.c.dry O2 corr. (SL)

9.5 Finding the DUSTHUNTER COM port

If you do not know your COM port: You can find the COM port with the Windows Device Manager (Administrator rights are not required).

- 1 Disconnect the connection of the DUSTHUNTER and your PC.
- 2 Input: `devmgmt.msc`

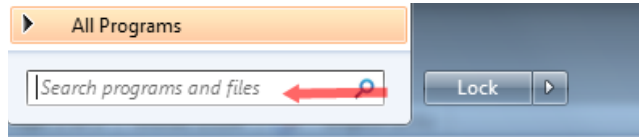

- 3 this message is shown:

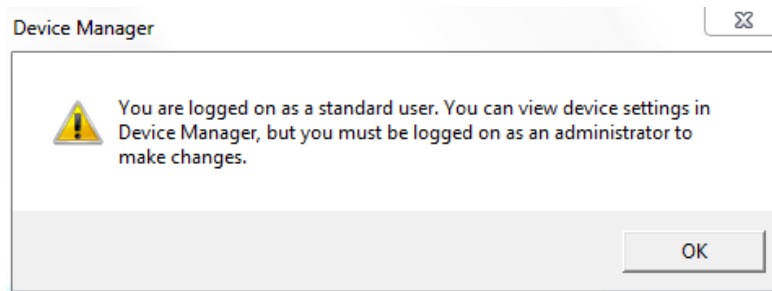

- 4 "OK"
- 5 The Device Manager opens.
See: "Ports (COM and LPT)"

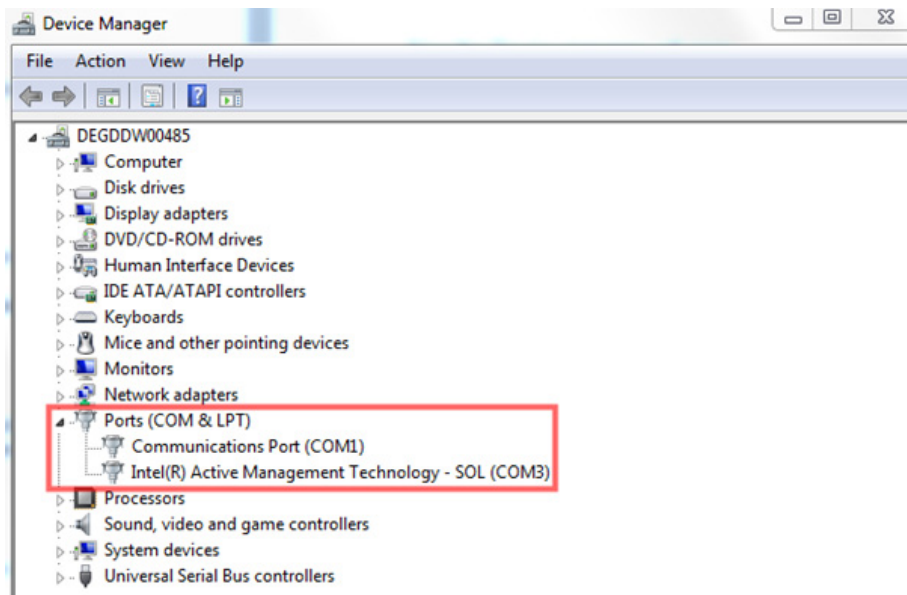

- 6 Connect the control unit with the computer. A new COM port is shown.

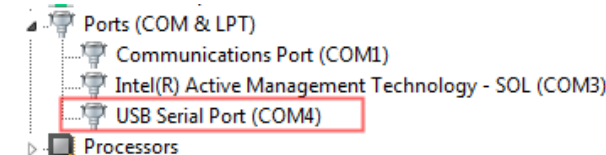

- 7 Use this COM port for communication.

10 Operation

10.1 Operating concept

The control unit of the measuring system has a display with LCD display, capacitive buttons for operation and status LEDs. Alternatively, the control unit can be connected to an external device and operated via the SOPAS ET software (see “SOPAS ET”, page 65).

- Many menus and functions can also be used via the display.
- The menus and functions are called up using the buttons.
- Status LEDs on the display indicate the current operating status.



NOTE:

The display can also be operated in the Ex-area.

10.2 User groups

Certain device functions are first accessible after a password has been entered.

Table 20: User groups on the control unit

User group		Access to
0	Operator	Displays measured values and system states No password required.
1	Authorized operator	Displays, inquiries as well as parameters required for commissioning or adjustment to customer-specific demands and diagnosis (preset password: 1234).

10.2.1 Changing the password for user groups

The password for the user groups on the control unit can be changed in the display settings in SOPAS ET (see “Changing display settings”, page 79).

10.3 Displays and operating elements MCUDH Ex-3K

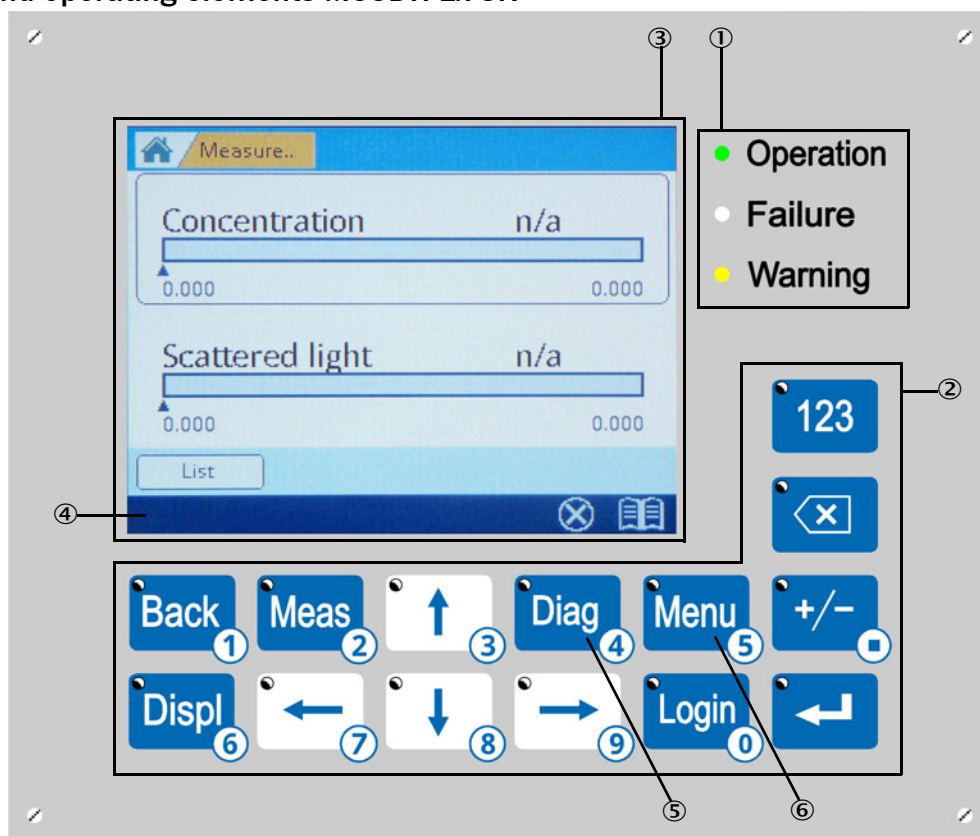















- ① Status LED
- ② Buttons
- ③ Display field
- ④ Status bar
- ⑤ Button for menu tree "Diagnosis"
- ⑥ Button for menu tree "Menu"

Fig. 42: Function elements, LC display, MCUDH Ex-3K control unit

10.4 MCUDH Ex-3K control unit buttons

The function shown depends on the menu currently selected. All buttons that can be selected for the respective menu are indicated by an illuminated LED.

Table 21: MCUDH Ex-3K control unit buttons

Button	Name	Function
	Login button	Displays the login.
	Back button	Returns to the previous display.
	Measured value key	Displays current measured values.
	Arrow up button	Navigates through menu items.
	Menu button	Calls up the Diagnosis menu.
	Menu button	Calls up the Settings menu.
	Display button	Calls up the display settings.
	Arrow left button	Navigates through menu items.
	Arrow down button	Navigates through menu items.
	Arrow right button	Navigates through menu items.
	Number button	Activates the numeric function of the buttons.
	Delete button	Deletes entries character by character.
	Plus-minus button	Sets plus or minus.
	Confirmation button	Confirms the entry.

11 Menus

11.1 Menu tree for the explosion-proof MCUDH Ex-3K control unit

The menu structure of the MCUDH Ex-3K control unit is divided into the functions for configuration (menu tree “Menu”) and the diagnostic functions (menu tree “Diagnostics”). The respective functions can be selected directly via the buttons (see “Displays and operating elements MCUDH Ex-3K”, page 83).

11.1.1 Menu tree “Menu”

Menu level	Designation	Explanation
1	I/O (MCU)	Control unit settings
1.1	Operating mode	Setting the maintenance mode or operating mode of the control unit
1.1.1		Set Maintenance / Set Operation
1.2	Adjustment	Start check cycle
1.2.1		Start check cycle
1.3	I/O Diagnosis	AO / AI / Device info
1.3.1	Analog output	Display current signal values n
1.3.2	Analog input	Display current signal values
1.3.3	Device Info	Control unit information text
1.4 I/O	Parameter	Analog interfaces, set to sensor type (Requires maintenance mode condition)
1.4.1	AO Parameter	Selection of analog output
		<i>The parameterization of the analog interfaces is identical, therefore the submenu for analog input and analog output is only listed once each.</i>
		<i>The identical number of the submenu and interface is marked with “x”.</i>
1.4.1.x	AO x	End values, Live Zero, measured value source
1.4.1.x.1	Limit low	Set limit low in mg/m ³ (password required)
1.4.1.x.2	Limit high	Set limit high in mg/m ³ (password required)
1.4.1.x.3	Live Zero	Set zero value for 0/2/4 mA signal strength
1.4.1.x.4	Measured value	Assign a measured value source to interface AO x :
	ConcA_SL	Dust concentration in operating condition
	ConcN	Dust concentration in standard condition
	SL	Scattered light intensity
1.4.2	AI Parameter	Analog input selection
1.4.2.x	AI x	Assign end values (temperature and pressure)
1.4.2.x.1	Limit low	Set limit low in °C / hPa (password required)
1.4.2.x.2	Limit high	Set limit high in °C / hPa (password required)

1.4.3	Variant	Assigning the sensor type (usually assigned ex works) <i>This assignment is only necessary when the system has been changed. All compatible sensor types are displayed for selection.</i>
2	Sensor	Settings on measuring device
2.1	Operating mode	Set the maintenance mode or operating mode of the sensor
2.2	Parameter	Set regression coefficients (see “Calibration for dust concentration measurement” , page 77) (Requires maintenance mode condition)
2.2.1	Coeff	Set Coefficient set 0-3 (see “Defining regression coefficients” , page 71)
2.2.2	cc2	Set regression coefficients (password required)
2.2.3	cc1	Set regression coefficients (password required)
2.2.4	cc0	Set regression coefficients (password required)
2.3	Diagnosis	Display diagnosis values
2.4	Device info	Display sensor information

11.1.2 Menu tree “Diagnosis”

Menu level	Designation	Explanation
1	I/O (MCU)	Display MCU error and warning messages
1.1	Error	Display MCU error messages
1.2	Warnings	Display MCU warning messages
2	Sensor	Display sensor error and warning messages
2.1	Error	Display sensor error messages
2.2	Warnings	Display sensor warning messages

11.2 Configuring on the control unit display

Some configuration options can also be set directly on the control unit display. Some important functions are explained here in more detail as examples. The numbers behind the submenus refer to the numbering of the menus in the previous subsections.

11.2.1 Configuring analog outputs and inputs of the control unit

- ▶ Set the control unit to “Maintenance” (1.1) and activate submenu “I/O Parameter” (1.4).
- ▶ Select the setting of the “Analog output parameters” (1.4.1) or the “Analog input parameters” (1.4.2) and enter the password (see “User groups”, page 82) using the control fields.
- ▶ Set the desired value using the operating fields. Press “Save” to save in the device.

11.2.2 Assigning the control unit to the sender/receiver unit

- ▶ Set the control unit to “Maintenance” (1.1) and activate submenu “I/O Parameter” (1.4).
- ▶ Select the setting of the “MCU variant” (1.4.3) and choose the type “DUSTHUNTER S”.
- ▶ Enter the password (see “User groups”, page 82) using the operating fields and save the selected type with “Saved”.

11.2.3 Enter the regression coefficients

- ▶ Set the sender/receiver unit to “Maintenance” (2.1) and activate submenu “I/O Parameter” (2.2).
- ▶ Select the desired parameter and enter the password (see “User groups”, page 82) with the operating fields.
- ▶ Enter the determined coefficient (see “Calibration for dust concentration measurement”, page 77) with the operating fields and save to the device with “Save”.

12 Maintenance

Take the following steps to set the measuring system to “Maintenance” mode before starting maintenance work.

- ▶ Connect the control unit with the computer. Start SOPAS ET.
- ▶ Connect with the MCU (see [“Connecting the control unit”, page 54](#)).
- ▶ Enter the Level 1 password (see [“Password for SOPAS ET menus”, page 65](#)).
- ▶ Set the sender/receiver unit to “Maintenance”: Click “Maintenance sensor”.

The screenshot shows two sections of the SOPAS ET menu. The top section, titled "Device Identification", contains a dropdown menu for "Selected variant" set to "DUSTHUNTER" and a text field for "Mounting Location" set to "SICK". The bottom section, titled "Offline Maintenance", contains a checkbox labeled "Activate offline maintenance" which is checked.

Fig. 43: SOPAS ET menu: MCU/Maintenance/Maintenance

Resuming measuring operation

Resume measuring operation after completing the work (deactivate the “Maintenance on/off” checkbox in the “Maintenance / Operation” window and click “Set State”).



- “Maintenance” mode can also be set using the buttons on the optional control unit LC display (see [“Menus”, page 85](#)) or by connecting an external maintenance switch to the terminals for Dig In2 (17, 18) in the MCUDH Ex-3K control unit (see [“MCUDHEx-3K processor board connections”, page 55](#)).
- An automatic functional check is not carried out during “Maintenance”.
- The value set for “Maintenance” is output on the analog output (see [“Setting the analog outputs parameters”, page 74](#)). This is also applicable when a malfunction is present (signaled on relay output).
- The “Maintenance” mode is reset when there is a voltage failure. In this case, the measuring system switches automatically to “Measurement” after the supply voltage is switched on again. If “Maintenance” mode is set via the external maintenance switch (see top item), the mode is also maintained when there is a voltage failure.

12.1 Safety information

The maintenance work to be carried out is limited to cleaning work and securing the purge gas supply.

**WARNING:****Risk of explosion during maintenance work**

Risk of explosion during maintenance work in the Ex-area.

- ▶ Maintenance work must only be carried out outside the Ex-area.
 - ▶ Only remove the sender/receiver unit from the duct when the surface temperature cannot be an ignition source.
 - ▶ If necessary, use a gas detector to verify the explosion hazard.
-

**DANGER:****Risk of explosion when using spare or expendable parts not approved for the Ex-area**

All spare and wear parts are tested by Endress+Hauser for use in Ex-areas. The use of other spare and expendable parts will invalidate the claim against Endress+Hauser because the ignition protection cannot be guaranteed.

- ▶ Use only original spare parts and expendable parts from Endress+Hauser.
-

**WARNING:****Health hazards through dangerous process residues**

The device may be contaminated by dangerous process residues.

- ▶ If process gas that is harmful to health is used, purge the unit thoroughly with purge gas, if necessary clean it with water and suitable agents.
-

12.2 Data backup

12.2.1 Data backup in SOPAS ET

All parameters relevant for recording, processing and input/output of measured values as well as current measured values can be saved in SOPAS ET and printed. This allows easy reentering of set device parameters as needed or registering device data and states for diagnostic purposes.

The following *options are available*:

- Saving as a project
Not only device parameters but also data logs can be saved.
- Saving as a device file
Saved parameters can be processed without a device connected and transferred to the device again later.

 Description, see SOPAS ET Help menu

- Saving as a protocol
Device data and parameters are registered in the Parameter protocol.
A Diagnosis protocol can be created for analysis of the device function and recognition of possible malfunctions.

Example for Parameter protocol

Dusthunter - Parameter protocol	
Type of device: DH SP100	
<i>Mounting location:</i>	
<hr/>	
Device information	Factory calibration settings
<i>Device version</i>	Gains
<i>Firmware version</i>	AN0-AN1 10.2000
<i>Serial number</i> 00008700	Relais 1 5.7000
<i>Identity number</i> 00000	Relais 2 31.0000
<i>Hardware version</i> 1.0	Relais 3 700.0000
<i>Firmware bootloader</i> V00.99.15	Offsets
Installation parameter	AN0 0.000450
<i>Bus adress</i> 1	Relais 1 0.000250
<i>Measurement laser temperature</i> inactiv	Relais 2 0.000050
Calibration coefficient for calculation of concentration	Relais 3 0.000010
<i>Coefficient set</i> Polynomial	Scattered light
Set 0	cc2 0.0000
cc2 0.0000	cc1 1.0000
cc1 1.0000	cc0 0.0000
cc0 0.0000	Current laser
Set 1 (fix)	cc2 0.0000
cc2 0.0000	cc1 30.3000
cc1 0.5000	cc0 0.0000
cc0 0.0000	Device temperature
Set 2 (fix)	cc2 0.0000
cc2 0.0000	cc1 100.0000
cc1 2.0000	cc0 -275.1500
cc0 0.0000	Current motor
Set 3 (fix)	cc2 0.0000
cc2 0.0000	cc1 2000.0000
cc1 3.0000	cc0 -19.5000
cc0 0.0000	Power supply
Device parameter	cc2 0.0000
Factory settings	cc1 10.8000
<i>Response time Sensor</i> 1.0 s	cc0 0.0000
<i>Response time diagnosis values</i> 10.0 s	

Fig. 44: DUSTHUNTER SP100 Parameter protocol (example)

12.3 Maintenance plan

Maintenance intervals

The equipment operator must specify the maintenance intervals. The period depends on existing operating parameters such as dust content and state, gas temperature, how the equipment is run and ambient conditions.

The work to be performed by the operator and execution must be documented in a Maintenance Manual.

Maintenance contract

Scheduled maintenance work can be carried out by the equipment operator. Only qualified personnel according to Section 1 should be allowed to do the work. If desired, Endress+Hauser Service or authorized Service support centers can carry out all maintenance work. Any repairs will be made by specialists onsite whenever possible.

12.4 Consumables and spare parts

Consumables and spare parts for the measuring system are listed in the Spare parts Section (see [“Spare parts”, page 124](#)).

12.5 Maintenance on the sender/receiver unit

Information on sender/receiver maintenance

- Commissioning, decommissioning, maintenance and cleaning may only be performed when it is verified that no explosive media are present in the ambient area as well as the measuring duct (verification by gas detector).
- Check the potential equalization for corrosion, other damage and secure contacts.
- Check the line and line socket for damage and strain relief.
- Check that the locking parts of the device are firmly locked (laser adjustment opening, cleaning opening, purge gas connection, protective cover, plug, sight glass).
- There is a risk of explosion when pulling the sender/receiver unit out from the duct due to the hot surface of the measuring probe and possibly escaping hot gases. Ensure the probe is either cold or the temperature is significantly below ignition temperature or no Ex atmosphere is present when removing the sender/receiver unit from the duct.



NOTICE:

Maintenance work

- ▶ Do not damage any device parts during maintenance work.
- ▶ Do not interrupt the purge gas supply.



To facilitate device maintenance, Endress+Hauser offers a set of spare and wear and tear parts. In addition to the required wear and tear parts for 5 years, this set contains a selection of small parts that may only be replaced with original parts if lost (see [“Spare parts DUSTHUNTER SP100 Ex-2K”, page 125](#)).

Clean the outside of the sender/receiver unit in regular intervals. Remove deposits with water or mechanically using suitable auxiliary means.

Clean the optical surfaces when deposits can be seen or before contamination reaches the limit value (30% for warning, 40% for malfunction).



If contamination on the glass surfaces cannot be removed with the optics cloth, clean the glass surfaces with soap suds and then dry.



WARNING:

Hazard through gas and hot parts

When cleaning the sender/receiver unit, toxic gases which can lead to poisoning can escape and hot parts can cause burns.

- ▶ Dismantle the sender/receiver unit from the duct for cleaning and then fit it back on again.
- ▶ Only carry out assembly work on systems with hazard potential (higher internal duct pressure, hot, aggressive, potentially explosive gases or dusts) when the system is at a standstill.
- ▶ Take suitable protection measures against possible local hazards or hazards arising from the equipment.

12.5.1 Cleaning the optics of the sender/receiver unit

- ▶ Remove the sender/receiver unit from the duct.
- ▶ Close off the flange with tube with a blind flange (see “Fastening technology”, page 126).
- ▶ Unscrew cover screw (4) from the cleaning opening for sender optics (see “Cleaning the optical surfaces”, page 92).
- ▶ Loosen fastening screws (2) for protective cover (1) and take the protective cover off.
- ▶ Clean the optics carefully with cotton swabs and, if necessary, light trap (3) as well.

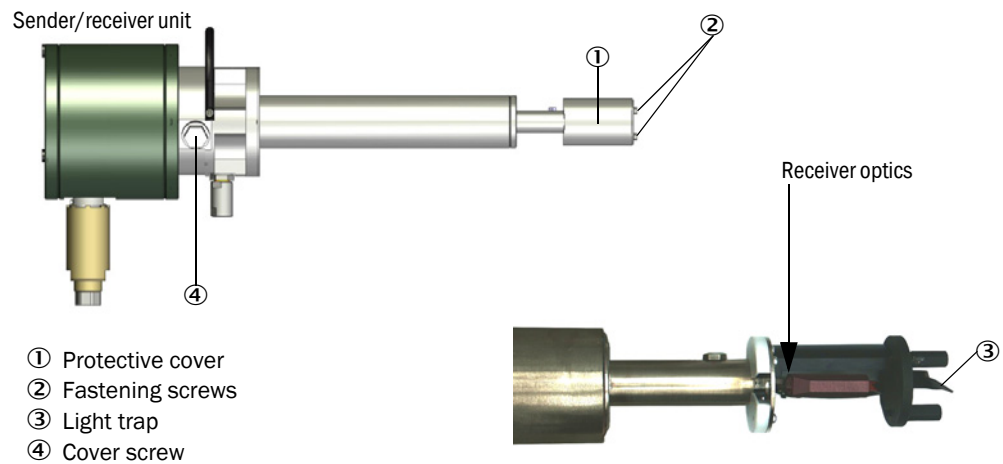

Fig. 45: Cleaning the optical surfaces

12.5.2 Checking the contamination value

- ▶ Start the function check. To do this, select device file “MCU” and move it to window “Project Tree”. Switch to directory “Adjustment / Function Check - Manual”. Click “Start Manual Function Check”.

The screenshot shows two sections of a software interface. The top section, titled "Device Identification", contains three input fields: "MCU" (a text box), "Selected variant" (a dropdown menu showing "DUSTHUNTER"), and "Mounting Location" (a text box showing "SICK"). The bottom section, titled "Start Manual Function Check", contains a single button labeled "Start Manual Function Check".

Fig. 46: SOPAS ET menu: MCU/Adjustment/Function Check - Manual

+i The function check can also be started via the LC display on the MCU (see “Menus”, page 85).

- ▶ Select the “DH SP100” device file in the “Project Tree” window, select the “Diagnosis / Check values” directory and check the contamination value.

The screenshot shows two sections of a software interface. The top section, titled "Device identification", contains a dropdown menu showing "DH SP100" and a text box for "Mounting location". The bottom section, titled "Check values", contains a table with three rows and two columns. The first column lists "Contamination", "Zero point", and "Span 70%". The second column lists "Drift". Each row has two input fields: one for the measured value and one for the drift value. A "Refresh" button is located at the bottom left of the "Check values" section.

		Drift
Contamination	0 %	+0.00 %
Zero point	0 %	+0.00 %
Span 70%	70 %	+0.00 %

Fig. 47: SOPAS ET menu: DH SP100/Diagnosis/Check values

- ▶ When the measured values for contamination, zero point and span are within the allowed ranges, save them to the device by clicking the “Refresh” button (“Check values” field); if not, repeat cleaning and check the contamination value again by triggering a renewed function check.

+i

- The contamination value can also be displayed on the LC display of the MCU (initiate a function check and select the “SP100/Diagnosis” menu, see “Menus”, page 85).
- The device is probably defective when the contamination value does not sink below the warning value (30%) despite several cleaning processes → contact Endress+Hauser Service.

- ▶ Reassemble the sender/receiver unit. Remove the cover from the flange with tube (blind flange). Fit the sender/receiver unit on the duct.
- ▶ Resume measuring operation (see “Resuming measuring operation”, page 88).

12.5.3 Non-return valve

Make a visual check of the non-return valve function at each service interval. Clean with suitable means (e.g. cotton swabs) when necessary. Replace the non-return valve with a spare part when it no longer functions (see [“Spare parts DUSTHUNTER SP100 Ex-2K”](#), page 125) (see [“Exchanging the non-return valve”](#), page 103).

12.5.4 Test equipment for linearity test

Measurement linearity can be checked using a linearity test. In this case, filter glasses with defined transmission values are positioned in the beam path and the values compared against those measured by the measuring system. Compliance within the allowed tolerance means the measuring system is working correctly. The filter glasses with holder required for the check are deliverable as a set including documentation and a carrying case (see [“Device check accessories”](#), page 127). The measuring function is checked by the function check and the linearity test.

12.6 Maintenance work on the sender/receiver unit

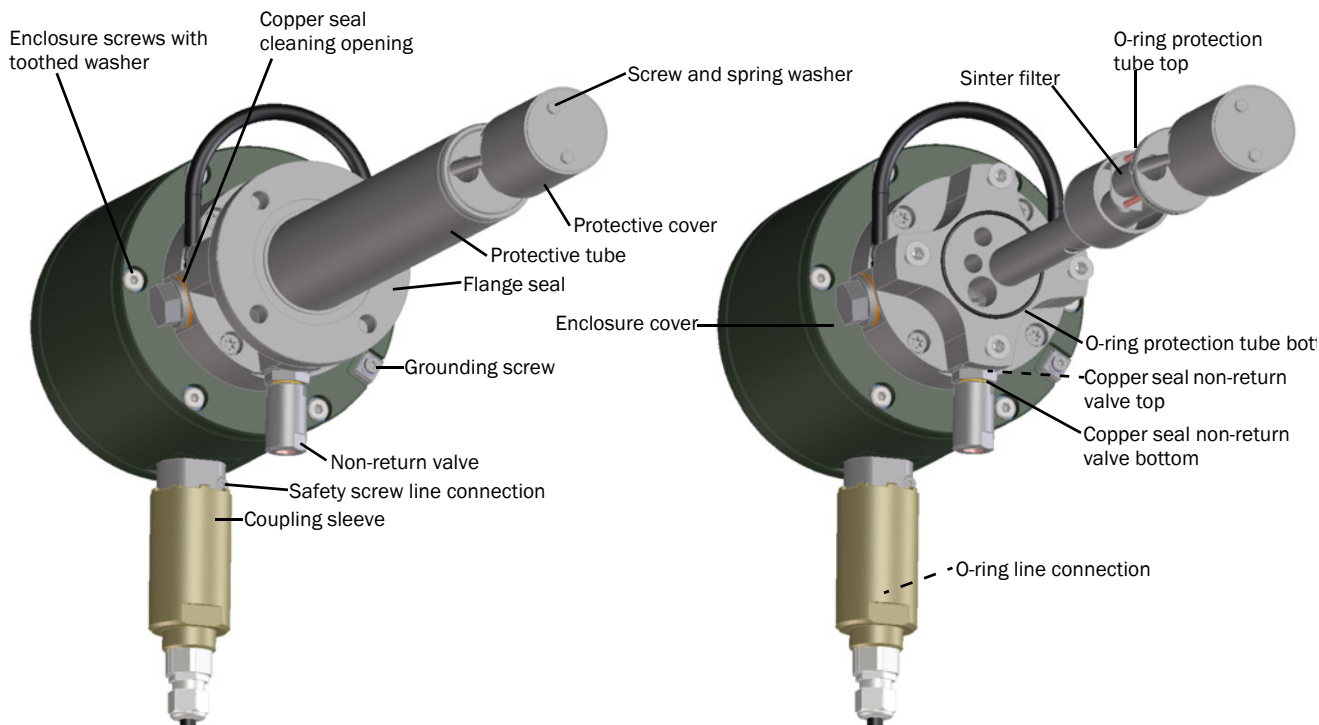

Fig. 48: Device views for sender/receiver unit maintenance

12.6.1 Power supply without control unit

Due to the regulations for explosion protection, some maintenance activities must not be carried out in the Ex-area; the sender/receiver unit must be dismantled and transported out of the Ex-area for this purpose. Observe the safety instructions in Section 2 and at the beginning of this Section before carrying out the activities. If a power supply is required for the work, you can establish this according to the following diagram. For the optional accessories see [“Options for MCUDH Ex-3K control unit”](#), page 127.

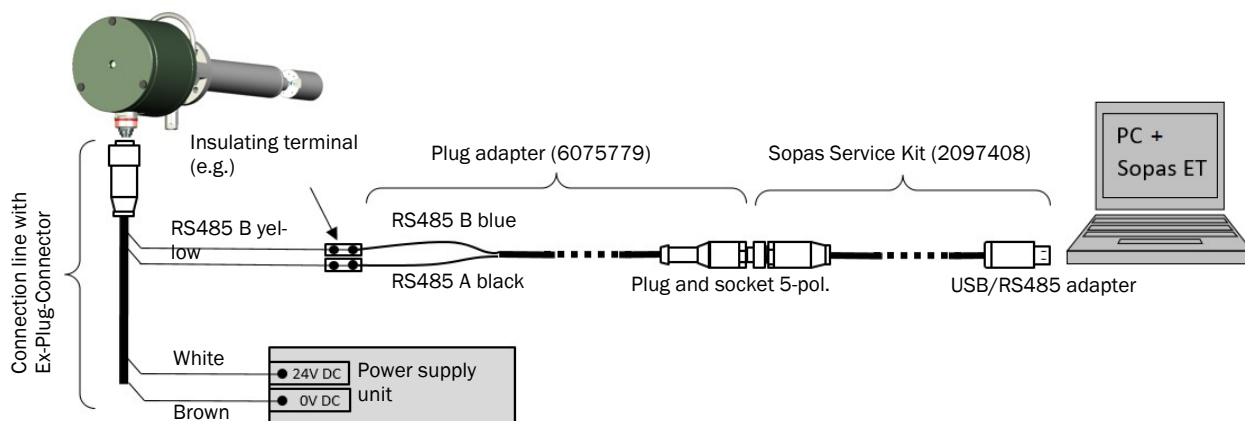

Fig. 49: Voltage supply for sender/receiver unit without the control unit

12.6.2 Checking laser alignment

To be done:	As required.
Ex-condition:	Check must be performed outside the Ex-area. 24 V DC power supply must be available outside the Ex-area.

Work steps:

- 1 Disconnect the entire device (control unit and sender/receiver unit) from the power supply. Disconnect the potential equalization line.
- 2 Unscrew the four flange screws and remove the sender/receiver unit from the duct (Caution: hot, aggressive and explosive gases may escape; the measuring probe may be hot) and allow it to cool down if necessary.
- 3 Switch off the purge gas supply. Remove the purge gas hose.
- 4 Unscrew screw 5328477 (see “Device views for sender/receiver unit maintenance”, page 95, views 1 and 2) until you can unscrew the coupling sleeve by turning it to the left and remove it downwards.
- 5 Remove the socket (see “Device views for sender/receiver unit maintenance”, page 95, view 3) from the connector plug.
- 6 Move the sender/receiver unit to an Ex-free zone.
- 7 Place the enclosure rear side of the sender/receiver unit on a flat surface.
- 8 Loosen both screws (SW 7) of the cover and remove the cover.
- 9 Switch the sender/receiver unit power supply on.
- 10 Check the alignment of the light trap with a suitable object or finger, as shown in the following Figure, the laser must be exactly in the middle.
- 11 Disconnect the sender/receiver unit from the power supply.
- 12 If necessary, adjust the alignment (see “Setting the laser alignment”, page 112).
- 13 Fit the cover and tighten the screws (2 Nm).
- 14 Bring the sender/receiver unit to the measuring location.
- 15 Fit the purge gas hose and switch on the purge gas supply.
- 16 Fit the sender/receiver unit on the duct. Tighten the four flange screws with a torque of 20 Nm.
- 17 Plug the female connector into the male connector.
- 18 Slide the coupling sleeve over the receiving bushing and screw on.
- 19 Tighten the securing screw of the Ex-Plug-Connector with 3 Nm, the coupling sleeve may have to be turned back a little bit for this purpose.
- 20 Put the complete device back into operation (connect potential equalization, switch on voltage and check measured and status values).

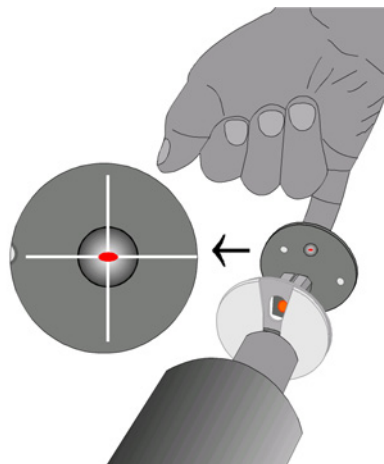

Fig. 50: Checking laser alignment

12.6.3 Exchanging the protection tube O-ring

Exchange criterion: In case of damage.

Ex-condition: Replacement can be carried out in the Ex-area when the absence of a potentially explosive atmosphere has been verified with a gas warning device.

Work steps:

- 1 Disconnect the entire device (control unit and sender/receiver unit) from the power supply. Disconnect the potential equalization line.
- 2 Loosen the four flange screws. Remove the sender/receiver unit from the duct. Allow to cool down.
- 3 Switch off the purge gas supply.
- 4 Place the enclosure rear side of the sender/receiver unit on a flat surface.
- 5 Loosen both screws (SW 7) of the protective hood. Remove the protective hood.
- 6 Loosen the four protection tube screws (PN 5340709). Turn the protection tube lightly and pull it off upwards.
- 7 Position a suitable tool (e.g. small screwdriver) under the "top" O-ring (5329376). Remove it from the groove - lightly rub the new O-ring with silicone grease. Put this back in the groove.
- 8 Position a suitable tool (e.g. small screwdriver) under the "bottom" O-ring (5340711). Remove it from the groove - lightly rub the new O-ring with silicone grease. Put this back in the groove.
- 9 Refit the probe protection tube. Fasten with the four protection tube screws (torque 15 Nm).
- 10 Switch on the purge gas supply.
- 11 Fit the sender/receiver unit on the duct flange (torque 20 Nm).
- 12 Put the complete device back into operation (connect potential equalization, switch on voltage and check measured and status values).

12.6.4 Exchanging the line inlet O-ring

Exchange criterion: Every 2 years (manufacturer's recommendation).

Ex-condition: Replacement can be carried out in the Ex-area when the absence of a potentially explosive atmosphere has been verified with a gas warning device.

Work steps:

- 1 Disconnect the entire device (control unit and sender/receiver unit) from the power supply. Disconnect the potential equalization line.
- 2 Unscrew screw 5328477 until you can unscrew the coupling sleeve by turning it to the left and remove it downwards.
- 3 Remove the female connector from the male connector.
- 4 Position a suitable tool (e.g. small screwdriver) under the "top" O-ring (5338626). Remove it from the groove - lightly rub the new O-ring with silicone grease. Put this back in the groove.
- 5 Position a suitable tool (e.g. small screwdriver) under the "bottom" O-ring (5338625). Remove it from the groove - lightly rub the new O-ring with silicone grease. Put this back in the groove.
- 6 Plug the female connector back into the male connector.
- 7 Screw the coupling sleeve on again so that the screw 5328477 can be screwed tight between the teeth again.
- 8 Put the complete device back into operation (connect potential equalization, switch on voltage and check measured and status values).

12.6.5 Exchanging the copper seal in the cleaning opening

Exchange criterion: Every 2 years (manufacturer's recommendation).

Ex-condition: Replacement can be carried out in the Ex-area when the absence of a potentially explosive atmosphere has been verified with a gas warning device.

Work steps:

- 1 Disconnect the entire device (control unit and sender/receiver unit) from the power supply. Disconnect the potential equalization line.
- 2 Use a wrench (SW 24) to unscrew the screw on the cleaning opening in an anti-clockwise direction (Caution: hot, aggressive and explosive gases may escape; the measuring probe may be hot).
- 3 Replace the old copper sealing ring (5324873) with a new one.
- 4 Retighten the screw (torque 70 Nm).
- 5 Put the complete device back into operation (connect potential equalization, switch on voltage and check measured and status values).

12.6.6 Exchanging the sinter filter

Exchange criterion: Every 2 years (manufacturer's recommendation).

Ex-condition: Replacement can be carried out in the Ex-area when the absence of a potentially explosive atmosphere has been verified with a gas warning device.

Work steps:

- 1 Disconnect the entire device (control unit and sender/receiver unit) from the power supply. Disconnect the potential equalization line.
- 2 Unscrew the four flange screws and remove the sender/receiver unit from the duct (Caution: hot, aggressive and explosive gases may escape; the measuring probe may be hot) and allow it to cool down if necessary.
- 3 Switch off the purge gas supply.
- 4 Place the enclosure rear side of the sender/receiver unit on a flat surface.
- 5 Loosen both screws (SW 7) of the cover and remove the cover.
- 6 Loosen the four protection tube screws (5340709) and remove the protection tube upwards by turning it slightly.
- 7 Loosen the two fixing screws and replace the sinter filter (7047714).
- 8 Slightly tighten the fixing screws again.
- 9 Fasten with the four protection tube screws (torque 15 Nm).
- 10 Switch on the purge gas supply.
- 11 Fit the sender/receiver unit on the duct and tighten the four flange screws with a torque of 20 Nm.
- 12 Put the complete device back into operation (connect potential equalization, switch on voltage and check measured and status values).

12.6.7 Exchanging the flange seal

Exchange criterion: Every 2 years (manufacturer's recommendation).

Ex-condition: Replacement can be carried out in the Ex-area when the absence of a potentially explosive atmosphere has been verified with a gas warning device.

Work steps:

- 1 Disconnect the entire device (control unit and sender/receiver unit) from the power supply. Disconnect the potential equalization line.
- 2 Unscrew the four flange screws and remove the sender/receiver unit from the duct (Caution: hot, aggressive and explosive gases may escape; the measuring probe may be hot) and allow it to cool down if necessary.
- 3 Replace the old flange seal (7047036) with a new one.
- 4 Fit the sender/receiver unit back on the duct flange (torque 20 Nm).
- 5 Put the complete device back into operation (connect potential equalization, switch on voltage and check measured and status values).

12.6.8 Replace potential equalization screw

Exchange criterion: In case of damage.

Ex-condition: Replacement can be carried out in the Ex-area when the absence of a potentially explosive atmosphere has been verified with a gas warning device.

Work steps:

- 1 Disconnect the entire device (control unit and sender/receiver unit) from the power supply. Disconnect the potential equalization line.
- 2 Unscrew the four flange screws and remove the sender/receiver unit from the duct (Caution: hot, aggressive and explosive gases may escape; the measuring probe may be hot) and allow it to cool down if necessary.
- 3 Loosen the grounding screw and replace all parts of the set (see [“Device views for sender/receiver unit maintenance”](#), page 95, view 4) with new parts.
- 4 Fit the sender/receiver unit back on the duct flange (torque 20 Nm).
- 5 Put the complete device back into operation (connect potential equalization, switch on voltage and check measured and status values).

12.6.9 Exchanging the enclosure cover O-ring

Exchange criterion: In case of damage.

Ex-condition: Exchange must be performed outside the Ex-area.

Work steps:

- 1 Disconnect the entire device (control unit and sender/receiver unit) from the power supply. Disconnect the potential equalization line.
- 2 Unscrew the four flange screws and remove the sender/receiver unit from the duct (Caution: hot, aggressive and explosive gases may escape; the measuring probe may be hot) and allow it to cool down if necessary.
- 3 Switch off the purge gas supply. Remove the purge gas hose.
- 4 Unscrew screw 5328477 (see [“Device views for sender/receiver unit maintenance”](#), page 95, views 1 and 2) until you can unscrew the coupling sleeve by turning it to the left and remove it downwards.
- 5 Remove the socket (see [“Device views for sender/receiver unit maintenance”](#), page 95, view 3) from the connector plug.
- 6 Move the sender/receiver unit to an Ex-free zone.

- 7 Place the enclosure rear side of the sender/receiver unit on a flat surface.
- 8 Loosen and remove the six enclosure screws.
- 9 Remove the enclosure cover with all attached parts upwards from the enclosure, this is best done by moving the cover slightly back and forth when pulling it out.
- 10 Place the cover and enclosure on a flat surface.
- 11 Loosen the two display screws on the cable connector with a screwdriver. Remove the cable connector.
- 12 Position a suitable tool (e.g. small screwdriver) under the O-ring (5337633) and take it out of the groove. Put the new O-ring into the groove (this O-ring must not be greased).
- 13 Replace the cable connector and tighten the two screws.
- 14 Insert the enclosure cover together with all attached parts back into the enclosure, taking care to align the cover with the measuring gap of the probe.
 - The non-return valve and the coupling sleeve are arranged in parallel on the vertical duct.
 - When the DUSTHUNTER SP100 Ex-2K is mounted on a horizontal duct, the non-return valve then points horizontally to the left (see [“Adapt the sender/receiver unit to the duct geometry”](#), page 62).
- 15 Fasten the cover to the enclosure by means of the six enclosure screws with a torque of 15 Nm.
- 16 Transport the sender/receiver unit to the measuring location.
- 17 Fit the purge gas hose and switch on the purge gas supply.
- 18 Fit the sender/receiver unit on the duct. Tighten the four flange screws with a torque of 20 Nm.
- 19 Plug the female connector into the male connector.
- 20 Slide the coupling sleeve over the receiving bushing and screw on to stop.
- 21 Tighten the securing screw of the Ex-Plug-Connector with 3 Nm, the coupling sleeve may have to be turned back a little bit for this purpose.
- 22 Put the complete device back into operation (connect potential equalization, switch on voltage and check measured and status values).

12.6.10 Adjusting the duct geometry

To be done: As required (see [“Adapt the sender/receiver unit to the duct geometry”](#), page 62)

Ex-condition: Adjustment must be performed outside the Ex-area.

Work steps:

- 1 Disconnect the entire device (control unit and sender/receiver unit) from the power supply. Disconnect the potential equalization line.
- 2 Unscrew the four flange screws and remove the sender/receiver unit from the duct (Caution: hot, aggressive and explosive gases may escape; the measuring probe may be hot) and allow it to cool down if necessary.
- 3 Switch off the purge gas supply. Remove the purge gas hose.
- 4 Unscrew screw 5328477 (see [“Device views for sender/receiver unit maintenance”](#), page 95, views 1 and 2) until you can unscrew the coupling sleeve by turning it to the left and remove it downwards.
- 5 Remove the socket (see [“Device views for sender/receiver unit maintenance”](#), page 95, view 3) from the connector plug.
- 6 Move the sender/receiver unit to an Ex-free zone.
- 7 Place the enclosure rear side of the sender/receiver unit on a flat surface.
- 8 Loosen and remove the six enclosure screws.
- 9 Remove the enclosure cover with all attached parts upwards from the enclosure, this is best done by moving the cover slightly back and forth when pulling it out.
- 10 Insert the enclosure cover together with all attached parts back into the enclosure, taking care to align the cover with the measuring gap of the probe.

- The non-return valve and the coupling sleeve are arranged in parallel on the vertical duct.
 - When the DUSTHUNTER SP100 Ex-2K is mounted on a horizontal duct, the non-return valve then points horizontally to the left (see [“Adapt the sender/receiver unit to the duct geometry”](#), page 62).
- 11 Fasten the cover to the enclosure by means of the six enclosure screws with a torque of 15 Nm.
 - 12 Transport the sender/receiver unit to the measuring location.
 - 13 Fit the purge gas hose and switch on the purge gas supply.
 - 14 Fit the sender/receiver unit on the duct. Tighten the four flange screws with a torque of 20 Nm.
 - 15 Plug the female connector into the male connector.
 - 16 Slide the coupling sleeve over the receiving bushing and screw on to stop.
 - 17 Tighten the securing screw of the Ex-Plug-Connector with 3 Nm, the coupling sleeve may have to be turned back a little bit for this purpose.
 - 18 Put the complete device back into operation (connect potential equalization, switch on voltage and check measured and status values).

12.6.11 Exchanging the protective hood

Exchange criterion: In case of damage.

Ex-condition: Replacement can be carried out in the Ex-area when the absence of a potentially explosive atmosphere has been verified with a gas warning device.

Work steps:

- 1 Disconnect the entire device (control unit and sender/receiver unit) from the power supply. Disconnect the potential equalization line.
- 2 Unscrew the four flange screws and remove the sender/receiver unit from the duct (Caution: hot, aggressive and explosive gases may escape; the measuring probe may be hot) and allow it to cool down if necessary.
- 3 Switch off the purge gas supply.
- 4 Place the enclosure rear side of the sender/receiver unit on a flat surface.
- 5 Loosen both screws (SW 7) of the cover and remove the cover.
- 6 Fit the new cover and tighten the screws (2 Nm).
- 7 Switch on the purge gas supply.
- 8 Fit the sender/receiver unit on the duct and tighten the four flange screws with a torque of 20 Nm.
- 9 Put the complete device back into operation (connect potential equalization, switch on voltage and check measured and status values).

12.6.12 Exchanging the copper seal of the non-return valve

Exchange criterion: In case of damage.

Ex-condition: Replacement can be carried out in the Ex-area when the absence of a potentially explosive atmosphere has been verified with a gas warning device.

Work steps:

- 1 Disconnect the entire device (control unit and sender/receiver unit) from the power supply. Disconnect the potential equalization line.
- 2 Unscrew the four flange screws and remove the sender/receiver unit from the duct (Caution: hot, aggressive and explosive gases may escape; the measuring probe may be hot) and allow it to cool down if necessary.
- 3 Switch off the purge gas supply and remove the purge gas hose.

- 4 Place the enclosure rear side of the sender/receiver unit on a flat surface.
- 5 Unscrew the non-return valve with a wrench (SW 22), then unscrew the reducer (SW 24) and separate these components if necessary.
- 6 Screw in the reducer with new copper gasket (5313977) and tighten with 30 Nm, center the sealing ring at the same time.
- 7 Screw in the non-return valve with new copper seal (5321372) and tighten with 20 Nm.
- 8 Fit the purge gas hose and switch on the purge gas supply.
- 9 Fit the sender/receiver unit on the duct. Tighten the four flange screws with a torque of 20 Nm.
- 10 Put the complete device back into operation (connect potential equalization, switch on voltage and check measured and status values).

12.6.13 Exchanging the non-return valve

Exchange criterion: In case of damage.

Ex-condition: Replacement can be carried out in the Ex-area when the absence of a potentially explosive atmosphere has been verified with a gas warning device.

Work steps:

- 1 Disconnect the entire device (control unit and sender/receiver unit) from the power supply.
- 2 Unscrew the four flange screws and remove the sender/receiver unit from the duct (Caution: hot, aggressive and explosive gases may escape; the measuring probe may be hot) and allow it to cool down if necessary. Disconnect the potential equalization line.
- 3 Switch off the purge gas supply.
- 4 Place the enclosure rear side of the sender/receiver unit on a flat surface.
- 5 Unscrew the non-return valve (SW 22) while holding the reducer with a wrench (SW 24).
- 6 Screw in new non-return valve with new sealing ring (5321372).
- 7 Connect the potential equalization: Switch on purge gas supply.
- 8 Fit the sender/receiver unit on the duct and tighten the four flange screws with a torque of 20 Nm.
- 9 Put the complete device back into operation (connect potential equalization, switch on voltage and check measured and status values).

12.6.14 Exchanging the button cell in the control unit**WARNING:****Risk of explosion when using an unspecified button cell**

There is a risk of explosion when a different type of button cell is used.

- ▶ Only use button cell type BR1632A with adapter ring (see [“Consumable parts, MCUDH Ex-3K control unit”, page 124](#)).

Exchange criterion: In case of need.

Ex-condition: Replacement can be carried out in the Ex-area when the absence of a potentially explosive atmosphere has been verified with a gas warning device.

Take suitable measures to prevent dust from entering the control unit enclosure when the door is open.

Work steps:

- 1 Disconnect the entire device (control unit and sender/receiver unit) from the power supply.
- 2 Make sure that the environment allows the door of the control unit to be opened and open it after the waiting time has elapsed.
- 3 Remove the old button cell on the circuit board and insert the new button cell with adapter ring (2114601) into the receptacle, observing the installation direction of the button cell. The circuit board is marked accordingly at this point.
- 4 Put the complete device back into operation (switch on voltage and check measured and status values, set date and time).

12.6.15 Exchanging the Ex power supply unit

Exchange criterion: In case of damage.

Ex-condition: Replacement can be carried out in the Ex-area when the absence of a potentially explosive atmosphere has been verified with a gas warning device.

Take suitable measures to prevent dust from entering the control unit enclosure when the door is open.

Work steps:

- 1 Disconnect the entire device (control unit and sender/receiver unit) from the power supply.
- 2 Make sure that the environment allows the door of the control unit to be opened and open it after the waiting time has elapsed.
- 3 Open the MCUDH with the control cabinet key.
- 4 Loosen three nuts (1) and remove transparent protective cover (2).



Fig. 51: Illustrations, power supply replacement

- 5 Disconnect power plug (3) and DC plug (4) from the power supply unit.
- 6 Use a screwdriver to unlock the hat rail lock of the power supply unit (pull the black plastic latch downwards) and remove the power supply unit from the hat rail.
- 7 Plug the new power supply unit onto the hat rail.
- 8 Connect power plug (3) and DC plug (4) to the power supply unit.
- 9 Place the protective cover on the three stud bolts and fasten it with the nuts.
- 10 Close the MCUDH Ex-3K with the control cabinet key.
- 11 Put the complete device back into operation (switch on voltage and check measured and status values).

12.6.16 Exchanging the RS485 Interface module

Exchange criterion: In case of damage.

Ex-condition: Replacement can be carried out in the Ex-area when the absence of a potentially explosive atmosphere has been verified with a gas warning device.

Take suitable measures to prevent dust from entering the control unit enclosure when the door is open.

Work steps:

- 1 Disconnect the entire device (control unit and sender/receiver unit) from the power supply.
- 2 Make sure that the environment allows the door of the control unit to be opened and open it after the waiting time has elapsed.
- 3 Open the MCUDH with the control cabinet key.

- 4 Loosen the connecting wires on the Interface module.

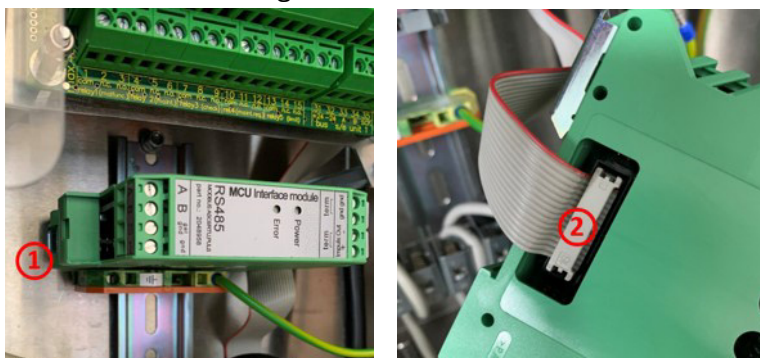

Fig. 52: Illustrations, exchanging the Interface module

- 5 Use a screwdriver to unlock hat rail lock (1) of the power supply unit and remove the module. Note how the ribbon cable is laid on the module.
- 6 Disconnect ribbon cable connector (2).
- 7 Connect ribbon cable connector (2) to the new Interface module.
- 8 Plug the new power supply unit onto the hat rail.
- 9 Connect the connecting wires to the new module.
- 10 Close the MCUDH Ex-3K with the control cabinet key.
- 11 Put the complete device back into operation (switch on voltage and check measured and status values).

13 Troubleshooting

13.1 Safety information

**WARNING:****Danger to health from gas and hot parts when working on the unit**

When clearing malfunctions on the sender/receiver unit, toxic gases which can lead to poisoning, can escape and hot parts can cause burns.

- ▶ For work on the device, remove the sender/receiver unit from the duct and fit it back on after the work is completed.
 - ▶ Observe the relevant safety regulations as well as the safety notices (see “Responsibility of user”, page 18) during all work.
 - ▶ Only carry out assembly work on systems with hazard potential (higher internal duct pressure, hot, aggressive, potentially explosive gases or dusts) when the system is at a standstill.
-

**WARNING:****Explosion hazard due to removal of hot parts from the duct**

There is a risk of explosion when pulling the sender/receiver unit out from the duct due to the hot surface of the measuring probe and possibly escaping hot gases.

- ▶ Take suitable protection measures against possible local hazards or hazards arising from the equipment.
-

**WARNING:****There is a risk of explosion when the enclosure is opened in a potentially explosive environment**

- ▶ Only open the flameproof enclosure of the sender/receiver unit when the device is within the safe zone.
-

13.2 Monitoring and diagnostic system

The device has an integrated system that continually checks the operating state of the sender/receiver unit and the control unit.

Messages for the two system components are categorized into error messages and warning messages depending on the anticipated effects:

Significance of warning messages

- Measuring results are not (yet) directly influenced by a deviating system state.
- Observance and clearance of the cause(s), e.g., through maintenance measures, are necessary to prevent subsequent errors or device damage

Significance of malfunction messages

- Measuring operation is no longer possible or no longer reliable.

“Diagnosis / Error messages/warnings” provides detailed information on the current device state. To display, connect the measuring system to SOPAS ET and start the corresponding device file.

Move the mouse to the respective message to display more details on the significance of individual messages in a separate window. Clicking on the display shows a short description of possible causes and corrections under “Help” (see [“Warning and malfunction messages in SOPAS ET”, page 109](#)).

Warning messages are output when internal limits for individual device functions/components are reached or exceeded which can then lead to erroneous measured values or an imminent failure of the measuring system.



Warning messages do not imply a malfunction of the measuring system. The current measured value continues to be output on the analog output.

13.3 Status display LEDs



Warning or error messages are output as follows:

- The respective relay on the control unit triggers (see [“Connection overview”, page 50](#)).
- “Maintenance requ.” or “Failure” is displayed in the status bar of the LC display of the control unit (see [“Operation”, page 82](#)). In addition, the respective LED goes on (“WARNING” for warnings, “FAILURE” for malfunctions).
After pressing the “Diag” button, possible causes are shown as short information in the menu “Diagnosis” after selecting the device (e.g. “Control unit MCU” or “DH SP100 Ex”).

Status display significance

Three LEDs next to the control unit display of the control unit indicate the operating state of the device.

Table 22: Control unit operating state

LED	Color	Significance
Operation 	Green	Measuring operation
Warning 	Yellow	Warning message
Failure 	Red	Function fault

13.4 Sender/receiver unit malfunctions

13.4.1 Malfunctions

Table 23: Sender/receiver unit malfunctions

Malfunction	Possible cause	Action
<ul style="list-style-type: none"> LEDs of the sender/receiver unit are not on No laser beam 	<ul style="list-style-type: none"> No supply voltage Connection line not connected correctly or defective Defective plug connector 	<ul style="list-style-type: none"> Check plug connectors and lines. Contact Endress+Hauser Service.

13.4.2 Warning and malfunction messages

Malfunctions listed below can probably be cleared onsite.

Table 24: Sender/receiver unit malfunctions that can be cleared

Message	Significance	Possible cause	Action
Contamination	Contamination of optical surfaces too high (see “Technical data”, page 118).	<ul style="list-style-type: none"> Deposits on the optical surfaces Unclean purge gas Incorrect laser alignment 	<ul style="list-style-type: none"> Clean optical surfaces (see “Maintenance on the sender/receiver unit”, page 91). Check laser alignment (see “Checking laser alignment”, page 96). Contact Endress+Hauser Service.
Span test, Zero point	Deviation from nominal value > ±2%.	<ul style="list-style-type: none"> Sudden change of measuring conditions during control value determination 	<ul style="list-style-type: none"> Repeat the functional check. Contact Endress+Hauser Service.
Cycle restriction	Wear and tear parts relevant for explosion protection must be replaced.	<ul style="list-style-type: none"> Number of function checks reached (see “Cycle restriction”, page 31) 	<ul style="list-style-type: none"> Send device in for factory inspection (see “Return delivery”, page 117).

Warning and malfunction messages in SOPAS ET

Device identification

DH SP100 Mounting location

Errors

Error selection :

EEPROM CRC sum parameter Version Parameter CRC sum factory settings
 Version Factory settings Threshold value Span test Monitor signal
 Contamination Overflow measured value Motor current
 Zero point Laser current to high
 Power supply (24V) < 18V Power supply (24V) > 30V

Warnings

Selection Warnings :

Reference value Contamination Contamination invalid Default factory parameter
 Laser current to high
 Power supply (24V) to low Power supply (24V) to high

Fig. 53: SOPAS ET menu: DH SP100/Diagnosis/Error messages/Warnings

Current warning or error messages, or earlier messages stored in the error memory, can be shown by selecting "actual" or "memory" in the "Selection" window.

- Display of error or warning: With LED symbol
- Description of error or warning: In the description field of SOPAS ET

13.5 Control unit malfunctions

13.5.1 Malfunctions

Table 25: Control unit malfunctions

Malfunction	Possible cause	Action
No display on the LCD	<ul style="list-style-type: none"> ● No supply voltage ● Connection line to LC display not connected or damaged ● Defective fuse 	<ul style="list-style-type: none"> ▶ Check voltage supply. ▶ Check connection line. ▶ Exchange fuse. ▶ Contact Endress+Hauser Service.

13.5.2 Warning and malfunction messages

Malfunctions listed below can probably be cleared onsite.

Table 26: Control unit malfunctions that can be cleared

Message	Significance	Possible cause	Action
AO configuration	The number of available and configured analog outputs is not identical.	<ul style="list-style-type: none"> ● No parameters set for AO ● Connection error ● Module failure 	<ul style="list-style-type: none"> ▶ Check configuration (see “Setting the analog outputs parameters”, page 74). ▶ Contact Endress+Hauser Service.
AI configuration	Number of available and configured analog inputs not identical.	<ul style="list-style-type: none"> ● No parameters set for AI ● Connection error ● Module failure 	<ul style="list-style-type: none"> ▶ Check configuration (see “Setting the analog inputs parameters”, page 76). ▶ Contact Endress+Hauser Service.
Interface module	No communication via interface module.	<ul style="list-style-type: none"> ● No parameters set for module ● Connection error ● Module failure 	<ul style="list-style-type: none"> ▶ Check configuration (see “Connecting to MCUDH Ex-3K control unit”, page 66) or (see “Connecting to MCUDH Ex-3K control unit”, page 66). ▶ Contact Endress+Hauser Service.
No sensor found	Sender/receiver unit not recognized	<ul style="list-style-type: none"> ● Communication problems on RS485 line ● Supply voltage problems 	<ul style="list-style-type: none"> ▶ Check system settings. ▶ Check connection line. ▶ Check voltage supply. ▶ Contact Endress+Hauser Service.
Variant configuration error	MCU setting does not match the connected sensor.	Sensor type has been changed	<ul style="list-style-type: none"> ▶ Correct application settings (see “Assigning the control unit to the sender/receiver unit”, page 71).
Test mode enabled	MCU in “Test” mode.		<ul style="list-style-type: none"> ▶ Deactivate “System Test” mode (“Maintenance” directory)

Warning and malfunction messages in SOPAS ET

Device Identification			
MCU	Selected variant	DUSTHUNTER S (SB50, SB100,SF100,SP100) ▾	Mounting Location
SICK			
System Status MCU			
<input type="radio"/> Operation	<input checked="" type="radio"/> Malfunction	<input type="radio"/> Maintenance Request	<input type="radio"/> Maintenance
<input type="radio"/> Function Check			
Configuration Errors			
<input type="checkbox"/> AO configuration	<input type="checkbox"/> AI configuration	<input type="checkbox"/> DO configuration	<input type="checkbox"/> DI configuration
<input type="checkbox"/> Sensor configuration	<input type="checkbox"/> Interface Module	<input type="checkbox"/> MMC/SD card	<input type="checkbox"/> Application selection
<input type="checkbox"/> "Limit and status" not possible	<input type="checkbox"/> Pressure transmitter type not supported	<input type="checkbox"/> Error current and LZ overlaps	<input type="checkbox"/> Option emergency air not possible
Errors			
<input checked="" type="radio"/> EEPROM	<input checked="" type="radio"/> I/O range error	<input checked="" type="radio"/> I ² C module	
<input checked="" type="radio"/> Firmware CRC	<input checked="" type="radio"/> AI NAMUR	<input checked="" type="radio"/> Power supply 5V	
<input checked="" type="radio"/> Power supply 12V	<input checked="" type="radio"/> Power supply(24V) <21V	<input checked="" type="radio"/> Power supply(24V) >30V	
<input checked="" type="radio"/> Transducer temperature too high - emergency air activated	<input checked="" type="radio"/> Key module not available	<input checked="" type="radio"/> Key module too old	
Warnings			
<input checked="" type="radio"/> Factory settings	<input checked="" type="radio"/> No sensor found	<input checked="" type="radio"/> Testmode enabled	
<input checked="" type="radio"/> Interfacemodule inactive	<input checked="" type="radio"/> RTC	<input checked="" type="radio"/> I ² C module	
<input checked="" type="radio"/> Power supply(24V) <22V	<input checked="" type="radio"/> Power supply(24V) >29V	<input checked="" type="radio"/> Flash memory	

Fig. 54: SOPAS ET menu: MCU/Diagnosis/Error messages/Warnings

- Display of error or warning: With LED symbol
- Description of error or warning: In the description field of SOPAS ET

13.6 Troubleshooting measures

13.6.1 Setting the laser alignment

In case the laser is no longer correctly aligned when checking the laser alignment (see [“Checking laser alignment”, page 96](#)), adjust the laser alignment anew.

Implementation criterion: As required.

Ex-condition: Adjustment must be performed outside the Ex-area.
24 V DC power supply must be available outside the Ex-area.

Work steps:

- 1 Disconnect the entire device (control unit and sender/receiver unit) from the power supply.
- 2 Unscrew the four flange screws and remove the sender/receiver unit from the duct (Caution: hot, aggressive and explosive gases may escape; the measuring probe may be hot) and allow it to cool down if necessary.
- 3 Switch off the purge gas supply. Remove the purge gas hose. Disconnect the potential equalization line.
- 4 Unscrew screw 5328477 (see [“Device views for sender/receiver unit maintenance”, page 95](#), views 1 and 2) until you can unscrew the coupling sleeve by turning it to the left and remove it downwards.
- 5 Remove the socket (see [“Device views for sender/receiver unit maintenance”, page 95](#), view 3) from the connector plug.
- 6 Bring the sender/receiver unit into an Ex-free zone, enable power supply of the sender/receiver unit.
- 7 Loosen both screws (SW 7) of the cover and remove the cover.
- 8 Loosen the four protection tube screws (5340709) and remove the protection tube upwards by turning it slightly.
- 9 Loosen and remove the six enclosure screws.
- 10 Remove the enclosure cover with all attached parts upwards from the enclosure, this is best done by moving the cover slightly back and forth when pulling it out.
- 11 Place the cover and enclosure on a flat surface.
- 12 Connect the power supply.
- 13 Tighten the 3 stud bolts for adjusting the base plate (see [“Three stud bolts for laser alignment”, page 113](#)) so that the springs underneath are tensioned.
- 14 Loosen the screws one whole turn.
- 15 Check the laser alignment (see [“Checking laser alignment”, page 96](#)) and adjust it with the stud bolts so that the laser beam is centered through the aperture opening.
- 16 Check that the laser beam also goes through the center of the opening of the aperture, if necessary, align the aperture to the laser (see [“Checking the laser beam for free passage”, page 113](#)).
- 17 Insert the enclosure cover together with all attached parts back into the enclosure, taking care to align the cover with the measuring gap of the probe.
 - The non-return valve and the coupling sleeve are arranged in parallel on the vertical duct.
 - When the DUSTHUNTER SP100 Ex-2K is mounted on a horizontal duct, the non-return valve then points horizontally to the left (see [“Adapt the sender/receiver unit to the duct geometry”, page 62](#)).
- 18 Fasten the cover to the enclosure by means of the six enclosure screws with a torque of 15 Nm.
- 19 Transport the sender/receiver unit to the measuring location. Connect the potential equalization.
- 20 Fit the purge gas hose and switch on the purge gas supply.

- 21 Fit the sender/receiver unit on the duct. Tighten the four flange screws with a torque of 20 Nm.
- 22 Plug the female connector into the male connector.
- 23 Slide the coupling sleeve over the receiving bushing and screw on to the stop.
- 24 Tighten the securing screw of the Ex-Plug-Connector with 3 Nm, the coupling sleeve may have to be turned back a little bit for this purpose.
- 25 Put the complete device back into operation (switch on voltage and check measured and status values).

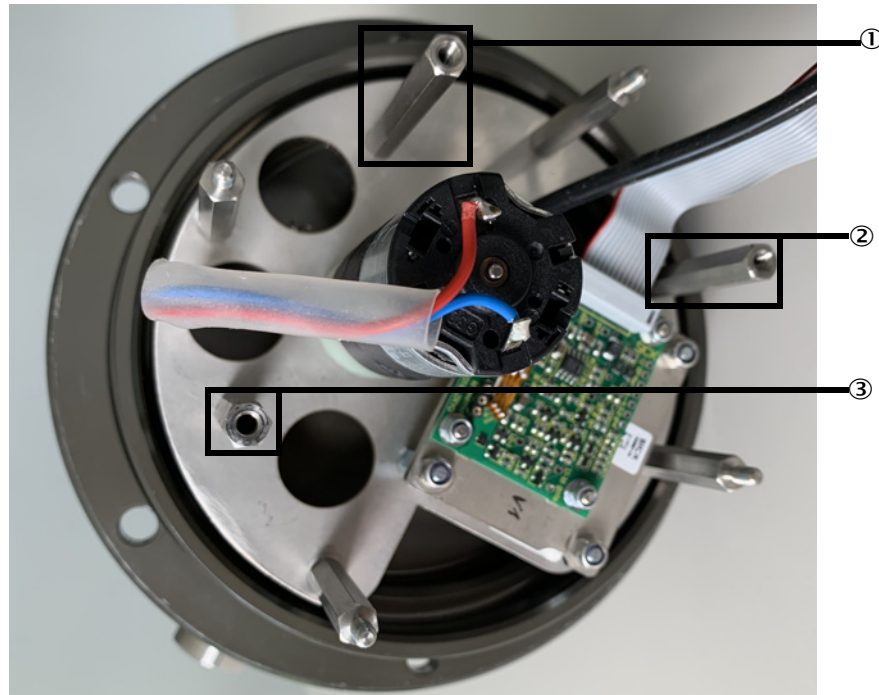

Fig. 55: Three stud bolts for laser alignment

13.6.2 Checking the laser beam for free passage

The laser beam must pass centrally through the aperture plate, readjust the aperture plate when this is not the case with a correctly adjusted laser.

Implementation criterion: As required.

Ex-condition: Adjustment must be performed outside the Ex-area.

Work steps:

- 1 Disconnect the entire device (control unit and sender/receiver unit) from the power supply.
- 2 Unscrew the four flange screws and remove the sender/receiver unit from the duct (Caution: hot, aggressive and explosive gases may escape; the measuring probe may be hot) and allow it to cool down if necessary.
- 3 Switch off the purge gas supply. Remove the purge gas hose. Disconnect the potential equalization line.
- 4 Unscrew screw 5328477 (see [“Device views for sender/receiver unit maintenance”, page 95](#), views 1 and 2) until you can unscrew the coupling sleeve by turning it to the left and remove it downwards.
- 5 Remove the socket (see [“Device views for sender/receiver unit maintenance”, page 95](#), view 3) from the connector plug.
- 6 Bring the sender/receiver unit into an Ex-free zone, enable power supply of the sender/receiver unit.
- 7 Loosen both screws (SW 7) of the cover and remove the cover.

- 8 Loosen the four protection tube screws (5340709) and remove the protection tube upwards by turning it slightly.
- 9 Check the beam transmission as shown in the Figure (see “Checking the beam path”, page 114).
- 10 Readjust the aperture plate when necessary.
- 11 Remove existing deposits in the beam path on the aperture opening, the sintered metal filter and on the outlet openings of the purge gas.
- 12 Refit the hood and protective tube on the unit.
- 13 Transport the sender/receiver unit to the measuring location. Connect the potential equalization.
- 14 Fit the purge gas hose and switch on the purge gas supply.
- 15 Fit the sender/receiver unit on the duct. Tighten the four flange screws with a torque of 20 Nm.
- 16 Plug the female connector into the male connector.
- 17 Slide the coupling sleeve over the receiving bushing and screw on to the stop.
- 18 Tighten the securing screw of the Ex-Plug-Connector with 3 Nm, the coupling sleeve may have to be turned back a little bit for this purpose.
- 19 Put the complete device back into operation (switch on voltage and check measured and status values).

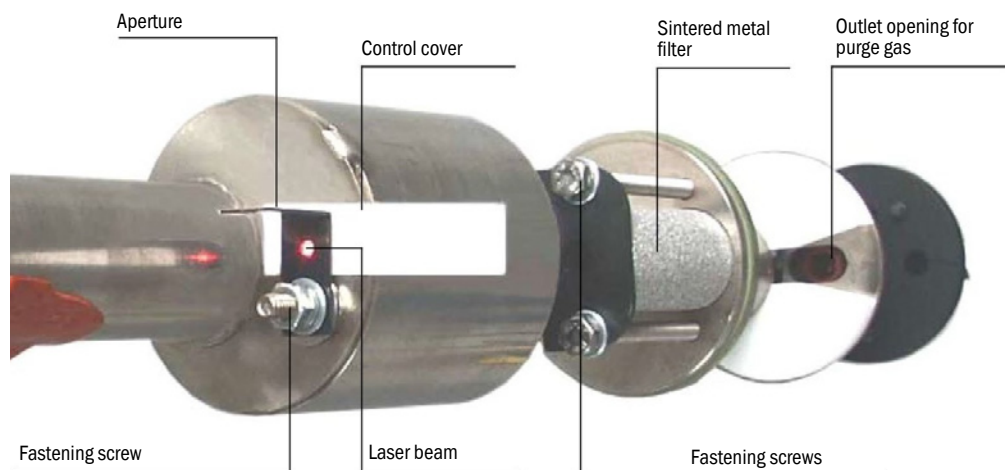

Fig. 56: Checking the beam path

13.6.3 Replacing the fuse



WARNING:

Risk of explosion when using an unspecified fuse

There is a risk of explosion when a different type of fuse is used.

- ▶ Only use fuses of type 522.723 from Eska.

- 1 Disconnect the control unit from the power supply and observe the waiting time before opening the door.
- 2 Take suitable precautions to prevent dust from entering the enclosure.
- 3 Open the control unit door. Remove fuse holder (1) and open.
- 4 Remove the transparent fuse cover.
- 5 Replace defective fuse (2) (see “Other accessories”, page 127).
- 6 Close and attach the fuse holder.
- 7 Close the door. Switch the power supply on again.

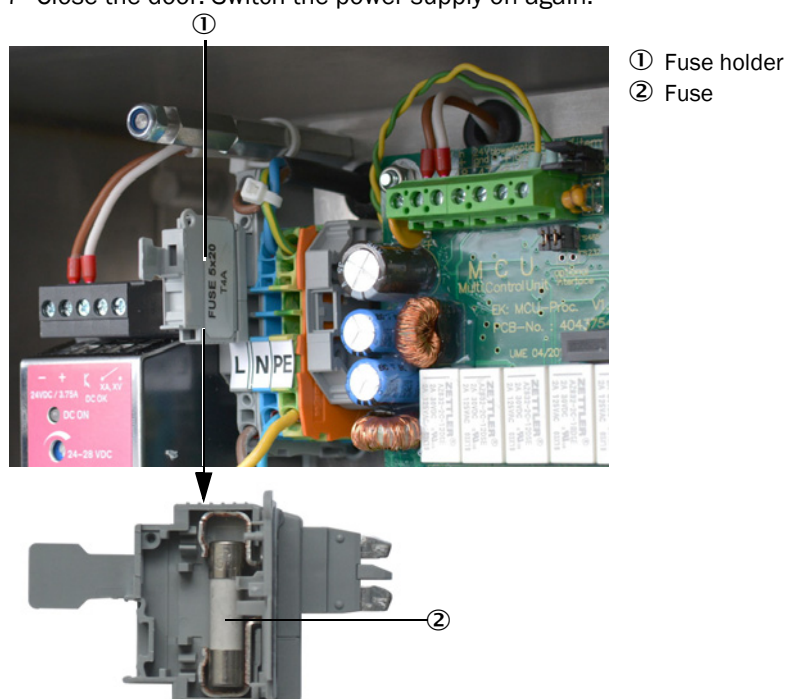

Fig. 57: Exchanging the fuse (shown with fuse cover removed)

13.6.4 Sending in devices

Information on sending a device to the factory for inspection or repair, see “Return delivery”, page 117.

14 Decommissioning

14.1 Switch-off states

The measuring system must be decommissioned:

- Immediately when the purge gas supply fails.
- When the system is to be put out of operation for a longer period of time (as from approx. 1 week).



NOTICE:

Purge gas supply

An interruption in the purge gas supply to a duct-mounted sender/receiver unit can damage the device.

- ▶ Never switch off or interrupt the purge gas supply when the sender/receiver unit is fitted on the duct.

Information on transport and storage of the device components: see “[Transport and storage](#)”, page 42.

14.2 Switching off and dismantling



WARNING:

Connect potential equalization when working on the measuring system

Static charge can lead to explosions.

- ▶ Connect the potential equalization as first task during assembly and as last task during disassembly.

Work to be performed

- ▶ Disconnect the connection line to the control unit.
- ▶ Dismantle the sender/receiver unit from the duct.



WARNING:

Danger to health through gas and hot parts when the device is removed from the duct

- ▶ Only remove the sender/receiver unit on systems with hazard potential (higher internal duct pressure, hot, aggressive, explosive gases/dusts) when the system is at a standstill.
- ▶ Take suitable protection measures against possible local hazards or hazards arising from the equipment.
- ▶ Secure switches that should not be switched on again for safety reasons with signs and safeguards to prevent unintentional switching.

-
- ▶ Close off the flange with tube with a blind flange (see “[Fastening technology](#)”, page 126).
 - ▶ Switch off the purge gas supply.
 - ▶ Unscrew the purge gas hose from the connections.
 - ▶ Disconnect the control unit from the supply voltage.
 - ▶ Disconnect the potential equalization.

14.3 Return delivery

Before shipping:

- ▶ Contact your local Endress+Hauser representative. The addresses are on the back cover of the Operating Instructions.
- ▶ The Endress+Hauser representative can advise you whether the defective device can be repaired locally or whether it would more advantageous for you to return the device for repair.
- ▶ Observe the following when returning the device to Endress+Hauser:
 - Repair flat rates.
 - Arrangements for packaging and transport (see “Transport and storage”, page 42).
 - Replacement devices or putting the device back into operation by Endress+Hauser Service.

Preparatory work

- ▶ Clean all device components. Remove any residues that are potentially hazardous to health.
- ▶ Complete the Return Form.
- ▶ Observe the transport instructions (see “Transport”, page 42).

14.4 Disposal

The metal parts of the devices can be disposed of as industrial scrap.

**NOTICE:****Disposal**

- ▶ Observe relevant local conditions for disposal of industrial waste.
-

**WARNING:****Disposal of subassemblies containing residual substances harmful to the environment**

The following subassemblies could contain substances that have to be disposed of separately:

- Electronics: capacitors, rechargeable batteries, batteries.
 - Display: Liquid contained in the LC display.
 - All parts in contact with the sample gas can be contaminated with harmful substances.
-

15 Technical data

DUSTHUNTER SP100 Ex-2K system (Zone 1/21)

Table 27: Technical data, complete system

Measured variable	Scattered light intensity (dust concentration output in mg/m ³ after gravimetric comparison measurement)
Measuring principle	Scattered light measurement (forward dispersion)
Spectral range	640 nm ... 660 nm Laser, protection class 2, capacity <1 mW
Measuring range (freely adjustable) Dust concentration	0...5 mg/m ³ / 0...500 mg/m ³ Higher measuring ranges on request
Certified measuring ranges Scattered light intensity	0...7.5 mg/m ³ (additional measuring ranges 0...10, 0...15, 0...50, 0...100, 0...200, 0...500 mg/m ³)
Response time (t90)	1 ... 600 seconds Freely adjustable
Precision	≤2% of measuring range end value
Process temperature Standard version DHSP-T2xxxEx2K High temperature version DHSP-T4xxxEx2K	-40 °C ... +220 °C -40 °C ... +400 °C
Process pressure With instrument air (from customer)	0 hPa... +3000 hPa
Process gas moisture	Non-condensing
Internal duct diameter	≥ 0.25 m
Compliances	Approved for systems requiring approval: 2001/80 /EC (13. BImSchV) 2000/76/EC (17. BImSchV) 27. BImSchV TA-Luft EN 15267 EN 14181 2010/75/EU U.S. EPA PS-11 compliant
Electrical safety	CE
Control functions	Automatic self-test (linearity, contamination, drift, aging) Contamination limits: At 30% warning, at 40% malfunction Manual linearity test via reference filter

DHSP-TxxxxEx-2K sender/receiver unit (Zone 1/21)

Table 28: Technical data sender/receiver unit DUSTHUNTER SP100 Ex-2K

Ambient temperature	-40 °C ... +60 °C	
Ex approvals	ATEX	II 2G Ex db op is IIC T6 Gb II 2D Ex tb op is IIIC T85 °C Db
	IECEX	Ex db op is IIC T6 Gb Ex tb op is IIIC T85 °C Db
Protection class	IP66	
Weight	Nominal length 435 mm	≤ 14.2 kg
	Nominal length 735 mm	≤ 15.2 kg
Power supply	Voltage	24 V
	Power consumption	≤ 8 W
Protection class	III	

Connection line with Ex-Plug-Connector

Table 29: Technical data, connection line with Ex-Plug-Connector

Temperature range	Movable	-5 °C ... +70 °C
	Fixed installation	-40 °C ... +80 °C
Minimum bending radius	Movable	15 × line diameter
	Fixed installation	6 × line diameter
Available lengths	5 m / 10 m / 25 m / 50 m / 100 m Other lengths on request	
Line type	Lappkabel, Unitronic Li2YCY v (TP) 2 mm ² ×2 mm ² ×0.5 mm ²	
Burning behavior	Flame-retardant acc. to IEC 60332-1-2	

MCUDH Ex-3K control unit (Zone 2/22)

Table 30: Technical data, MCUDH Ex-3K control unit

Description	Unit to control system components, and evaluate and output the data you provide
Ambient temperature Version with power supply unit MCUDH Ex-3K NSxxx	-25 °C ... +50 °C
Version without power supply unit MCUDH Ex-3K N2xxx	-40 °C ... +60 °C
Ex approvals Version with power supply unit MCUDH Ex-3K NSxxx	II 3G Ex ec nA nC IIC T4 Gc II 3D Ex tc IIIC T85 °C Dc
Version without power supply unit MCUDH Ex-3K N2xxx	II 3G Ex ec IIC T4 Gc II 3D Ex tc IIIC T85 °C Dc
Protection class	IP65
Analog outputs	1 output 0/2/4 ... 20 mA, 750 Ω Galvanically isolated
Analog inputs	2 inputs 0...20 mA, measuring resistance 110 Ω Not galvanically isolated
Digital outputs	5 relay contacts: 48 V, 1 A Potential-free; for status signals
Digital inputs	4 potential-free contacts
MODBUS Type of field bus integration	RTU RS-485 (via optional Interface module; only one module per MCU possible)
Ethernet Option 1 Option 2	Ethernet CoLa-B (remote in safe area) Ethernet CoLa-B (remote in safe area)
Display	LC display Status LEDs: "Operation", "Warning" and "Malfunction"
Operation	Via display or SOPAS ET software
Dimension (W×H×D)	300 mm 300 mm 220 mm
Weight	≤ 8.8 kg
Power supply Voltage	90 V...250 V (AC) 24 V (DC) (external supply)
Frequency	47 Hz ... 63 Hz
Power consumption	Max. 30 W
Protection class Version with power supply unit MCUDH Ex-3K NSxxx Version without power supply unit MCUDH Ex-3K N2xxx	I III

15.1 Dimensional drawings and part numbers

All measures are specified in mm.

15.1.1 DHSP100Ex-2K sender/receiver unit

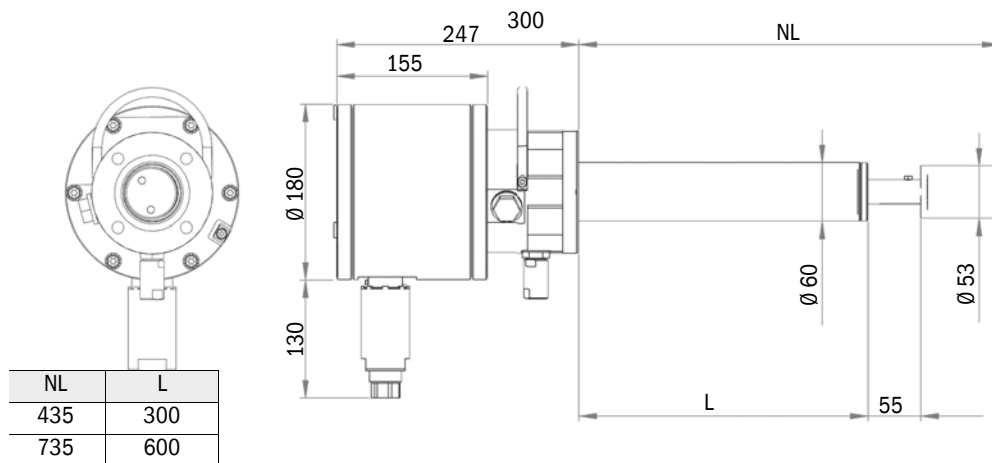

Fig. 58: Dimensions, sender/receiver unit DUSTHUNTER SP100 Ex-2K

Table 31: Part numbers, sender/receiver unit

Name	Part No.
Sender/receiver unit DHSP-T4V11EX2KT6	1102016
Sender/receiver unit DHSP-T2V11EX2KT6	1092920
Sender/receiver unit DHSP-T2H11EX2KT6	1109313
Sender/receiver unit DHSP-T4V21EX2KT6	1102017
Sender/receiver unit DHSP-T2V21EX2KT6	1101992

15.1.2 Flange with tube

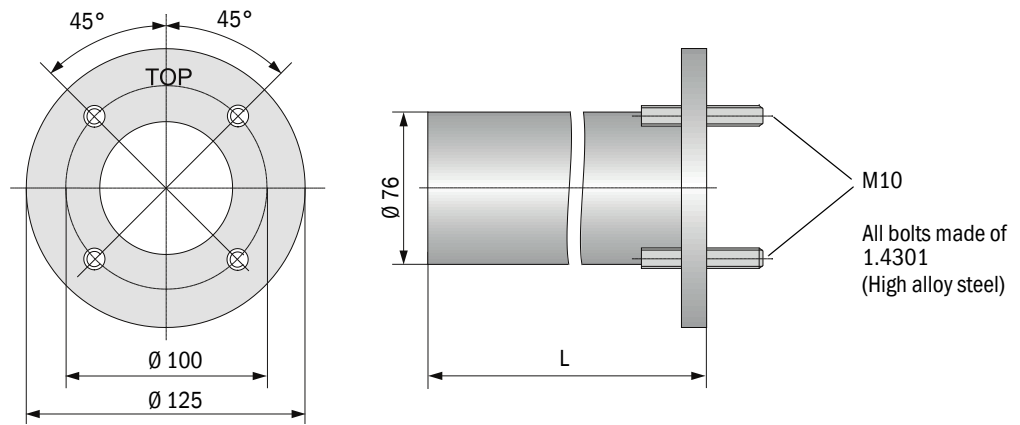
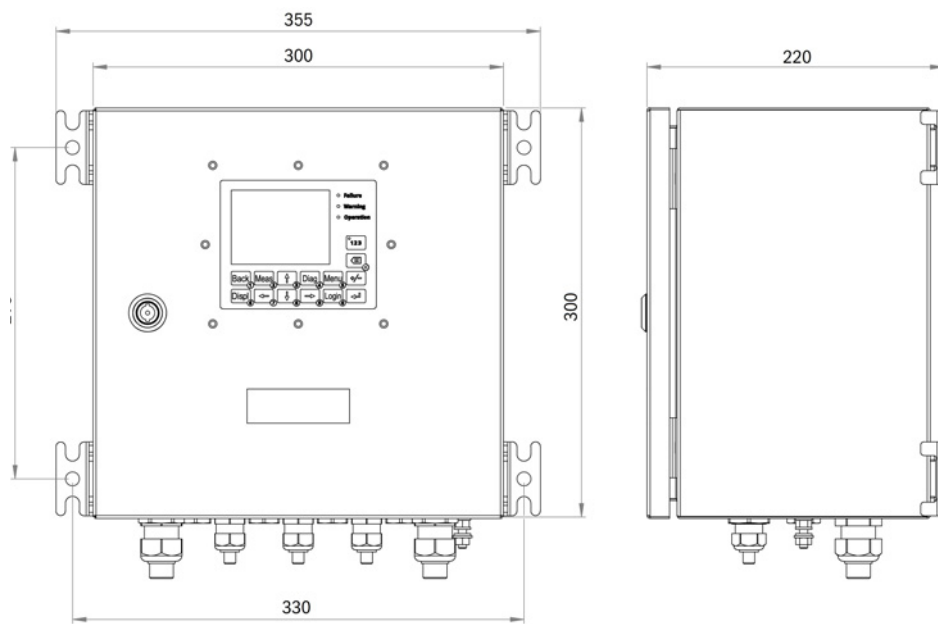

Fig. 59: Dimensions, flange with tube

Table 32: Part numbers, flange with tube

Name	Part No.	Usage on
Material flange: 1.4571 (high-alloy steel); material tube: 1.0254 (unalloyed structural steel)		
Flange with tube, Øi 70 mm, L 130 mm	2115419	DHSP-Txx1, DHSP-Txx2
Flange with tube, Øi 70 mm, L 240 mm	2115420	
Flange with tube, Øi 70 mm, L 500 mm	2115421	DHSP-Txx2
Material, flange and tube: 1.4571 (high-alloy steel), with 3.1 material certificate		
Flange with tube, Øi 70 mm, L 130 mm, with 3.1 material certificate	2115404	DHSP-Txx1, DHSP-Txx2
Flange with tube, Øi 70 mm, L 240 mm, with 3.1 material certificate	2115417	
Flange with tube, Øi 70 mm, L 500 mm, with 3.1 material certificate	2115418	DHSP-Txx2

15.1.3 MCUDH Ex-3K control unit



Alternatively for mounting the MCUDH Ex-3K control unit, the fastening brackets can be loosened with a ring spanner (SW13) and positioned from the long sides to the top and bottom. Observe changed dimensions.

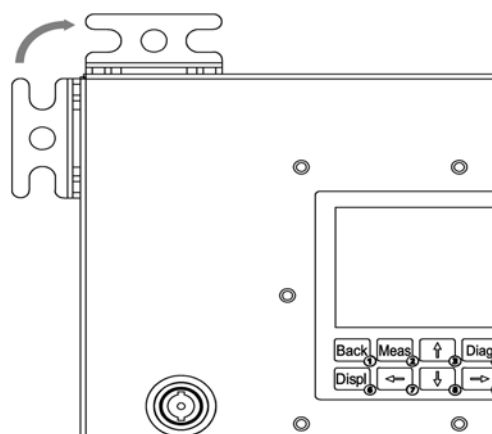

Fig. 60: Dimensions, MCUDH Ex-3K control unit

Table 33: Part numbers, MCUDH Ex-3K control unit

Name	Part No.
MCUDH Ex-3K NSYDN00000MNOE control unit in wall enclosure, supply voltage 115/230 V AC, without integrated purge gas supply, with display, with integrated Interface module RS485 Modbus ASCII/RTU	1106647
MCUDH Ex-3K NSYDN00000NNOE control unit in wall enclosure, supply voltage 115/230 V AC, without integrated purge gas supply, with display, without integrated interface module	1109325
MCUDH Ex-3K N2YDN00000MNOE control unit in wall enclosure, supply voltage 24 V DC, without integrated purge gas supply, with display, with integrated Interface module RS485 Modbus ASCII/RTU	1109326
MCUDH Ex-3K N2YDN00000NNOE control unit in wall enclosure, supply voltage 24 V DC, without integrated purge gas supply, with display, without integrated interface module	1109327

16 Spare parts



Only spare and consumable parts from Endress+Hauser may be used.

16.1 Consumable parts

16.1.1 Consumable parts DUSTHUNTER SP100 Ex-2K

Spare and consumable parts set

Table 34: Spare and consumable parts set, SP100 Ex-2K sender/receiver unit

Name	Part No.
Spare and consumable parts set DUSTHUNTER SP100 Ex-2K	2115270

The components contained in the set are listed in the following Table with their quantity and a recommendation for the replacement interval. For a description of the work necessary for replacement, see [“Maintenance work on the sender/receiver unit”](#), page 95.

Table 35: Contents, spare and consumable parts set, SP100 Ex-2K sender/receiver unit

Name	Number	Replacement interval
O-ring, line inlet	3	Every 2 years
Copper seal, cleaning opening	3	Every 2 years
Flange seal	3	Every 2 years
Sintered metal filter	3	Every 2 years
O-ring, protection tube (top and bottom)	2 1	In case of damage.
Grounding screw, complete	1	In case of damage
O-ring, enclosure	1	In case of damage
Securing screw, plug	1	In case of damage
Enclosure with toothed washer	6	In case of damage
Screw, protective tube fastening	4	In case of damage
Screw, protective cover fastening with spring washer	2	In case of damage
Copper seal, non-return valve	2×1	In case of damage

Consumable parts to be purchased separately

Table 36: Consumable parts, SP100 Ex-2K sender/receiver unit

Name	Part No.
Flange seal k100	7047036
Sinter filter	7047714
Optics cloth	4003353

16.1.2 Consumable parts, MCUDH Ex-3K control unit

Table 37: Consumable parts, MCUDH Ex-3K

Name	Part No.
Button cell BR1632A	2114601



The use of a button cell other than that listed in the Table is not permitted in Ex-areas.

16.2 Spare parts

16.2.1 Spare parts DUSTHUNTER SP100 Ex-2K

Table 38: Spare parts, SP100 Ex-2K sender/receiver unit

Name	Part No.
Protection tube, NL 435 mm 3.1 (SS)	4103878
Protection tube, NL 735 mm 3.1 (SS)	4103880
Protective hood 3.1 (SS)	4093574
Non-return valve G1/4"	5320060
Non-return valve G1/2"	5320060

16.2.2 Spare parts, MCUDH Ex-3K control unit

Table 39: Spare parts, MCUDH Ex-3K

Name	Part No.
Set, line inlets, MCUDH Ex-3K (2× M20 (6...12 mm); 2× M20 (10...14 mm); 2× M25 (14...18 mm))	2115594
Fuse sets T 4 A 250 V	2115062

17 Accessories

17.1 Weather protection

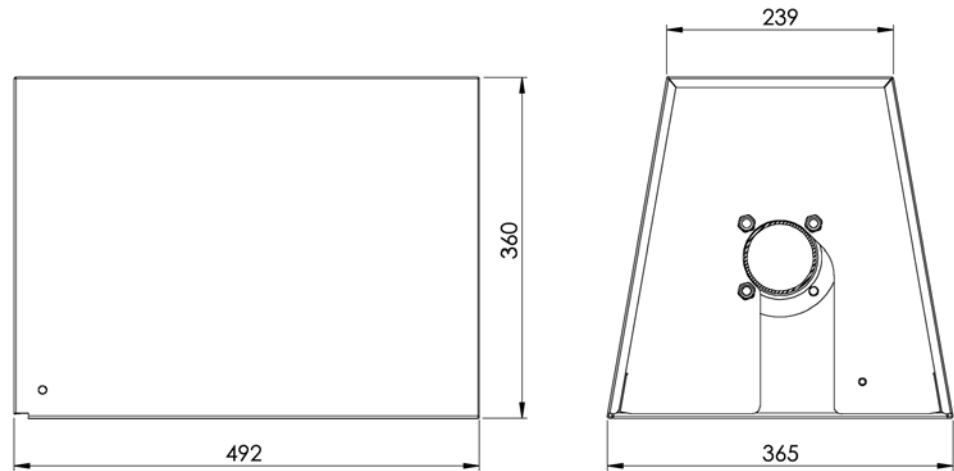

Fig. 61: Weather hood for the sender/receiver unit (dimensions in mm)

Table 40: Part number, weather hood

Name	Part No.
Weather hood for sender/receiver unit with NL up to 735 mm, for Ex protection zone	2108971

17.2 Connection technology

17.2.1 Connection line with Ex-Plug-Connector

Table 41: Part numbers, connection lines, control unit to sender/receiver unit

Name	Part No.
Ex-plug connector with 5 m line	2101603
Ex-plug connector with 10 m line	2114891
Ex-plug connector with 25 m line	2114892
Ex-plug connector with 50 m line	2114893
Ex-plug connector with 100 m line	2114894
Other lengths on request	

17.3 Fastening technology

Table 42: Part numbers, assembly parts

Name	Part No.
Assembly kit flange (for sender/receiver unit with NL 435 mm and 735 mm)	2018184
Blind flange for temporary closing of the flange with tube	4108524

17.4 Optional accessories

17.4.1 Options for MCUDH Ex-3K control unit

The interface module Modbus ASCII/RTU is a retrofit option when an MCUDH Ex-3K without integrated module was ordered. The optional interface modules Ethernet Type 2 and Modbus TCP/IP of the MCUDH Ex-3K are not to be used in Ex-areas. To use these options, an MCUDH Ex-3K with integrated Interface module is required and a signal line must be laid from the integrated module in the Ex-area to which the optional modules can be connected (see [“Interface module \(option\) of the MCUDH Ex-3K”](#), page 59).

Table 43: Part numbers, optional accessory, MCUDH Ex-3K control unit

Name	Part No.
Module, Interface Modbus ASCII/RTU	2048958
Module, Interface Ethernet CoLa-B (remote separate module)	2069666
Module, Interface Modbus TCP/IP (remote separate module)	2069664
Remote display 100, without power supply unit	2117058
Remote display 100, with power supply unit	2117059
SOPAS Service Kit (adapter cable USB-RS485)	2097408
Plug adapter for SOPAS Service Kit	6075779
24 V power supply unit for supplying optional remote modules	6059059

17.5 Other accessories

17.5.1 Device check accessories

Table 44: Article numbers, device checking

Name	Part No.
DHSP control filter set for linearity testing	2049045

18 Annex

18.1 Compliances

The technical design of this device complies with the following EU directives and EN standards:

- EU directive: 2014/30/EU (EMC)
- EU directive: 2011/65/EU (RoHS)
- EU directive: 2014/34/EU (ATEX)

Applied EN standards:

- EN 60529, Degrees of protection provided by enclosures (IP code)
- EN 61010-1 Safety requirements for electrical equipment
- EN 61000-6-2 Electromagnetic compatibility
- EN 61326, Electrical equipment for measurement, control and laboratory use - EMC requirements
- EN 50581, Guideline for the implementation of RoHS
- EN 14181, Stationary source emissions - Quality assurance of automated measuring systems
- EN 60079-0:2012-08
- EN 60079-15:2010-05
- EN 60079-28:2015-09
- EN 60079-31:2014-07
- EN 60079-1:2018
- EN 60079-7:2015

18.2 Electrical protection

- MCUDH: Protection class 1 according to EN 61010-1.
- Insulation coordination: Overvoltage category II in accordance with EN61010-1.
- Contamination: The device operates safely in an environment up to degree of contamination 2 according to EN 61010-1 (usual, not conductive contamination and temporary conductivity by occasional moisture condensation).
- Electrical energy: The wiring system to the power supply voltage of the system must be installed and fused according to the relevant regulations.

18.3 Approvals

Approvals

DUSTHUNTER SP100 Ex-2K is performance-tested according to EN 15267 and may be used for continuous emission monitoring in systems requiring approval and systems according to EU Directives.

18.4 Licenses

Exclusion of liability

The firmware for this device has been developed using Open Source Software. Any changes to the Open Source components are in the general responsibility of the user. All warranty claims are excluded in this case.

The following exclusion of liability applies to the GPL components in relation to the rights holders: This program is distributed in the hope that it will be of use, but with no guarantee of this; neither is there any implied guarantee of marketability or suitability for a particular purpose. See GNU (General Public License) for details. With regard to the other Open Source components, we refer to the liability disclaimers of the copyright holders in the license texts on the CD delivered.

Software licenses

In this product, Endress+Hauser uses unchanged and, as far is necessary and in compliance with relevant license conditions, changed Open Source Software.

The firmware of this device is therefore subject to the copyrights listed on the CD delivered. Please refer to the CD delivered for a complete list of the Open Source programs used as well as the relevant license conditions.

8029852/AE00/V1-0/2021-02

www.addresses.endress.com
