

Operating Instructions

MCS200HW

Multicomponent Gas Analyzer



Described product

MCS200HW (version with HF)

Manufacturer

Endress+Hauser SICK GmbH+Co. KG
Bergener Ring 27
01458 Ottendorf-Okrilla

Legal information

This work is protected by copyright. Any rights derived from the copyright shall be reserved for Endress+Hauser SICK GmbH+Co. KG. Reproduction of this document or parts of this document is only permissible within the limits of the legal determination of Copyright Law. Any modification, shortening or translation of this document is prohibited without the express written permission of Endress+Hauser SICK GmbH+Co. KG.

The trademarks stated in this document are the property of their respective owner.

© Endress+Hauser SICK GmbH+Co. KG. All rights reserved.

Original document

This document is an original document of Endress+Hauser SICK GmbH+Co. KG.



Contents

1	About this document.....	7
1.1	Function of this document.....	7
1.2	Scope of application.....	7
1.3	Target groups.....	7
1.4	Further information.....	7
1.5	Symbols and document conventions.....	7
1.5.1	Warning symbols.....	8
1.5.2	Information symbols.....	8
1.6	Data integrity.....	9
2	Safety information.....	10
2.1	Basic safety information.....	10
2.1.1	Electrical safety.....	10
2.1.2	Dangerous substances.....	11
2.2	Warning information on device.....	11
2.3	Intended use.....	12
2.4	Requirements on the personnel's qualification.....	12
3	Product description.....	13
3.1	Product identification.....	13
3.2	Gas supply terminology.....	14
3.3	Layout and function.....	14
3.3.1	System overview.....	14
3.3.2	Analyzer cabinet.....	15
3.3.3	Gas sampling unit.....	17
3.3.4	Sample gas line.....	18
3.3.5	Hose bundle line.....	19
3.3.6	Instrument air conditioning.....	19
3.3.7	Integrated GMS811 FIDORi (option).....	20
3.4	Extended interfaces (option).....	20
3.5	Remote maintenance (option).....	20
4	Transport and storage.....	22
4.1	Transport.....	22
4.2	Storage.....	23
5	Mounting.....	24
5.1	Safety.....	24
5.2	Scope of delivery.....	24
5.3	Overview of mechanical and electrical installation.....	24
5.4	Installation sequence.....	25
5.4.1	Mounting at target location.....	25
5.4.2	Installing the sample gas line.....	26
5.4.2.1	Laying the sample gas lines.....	26

	5.4.2.2	Connecting the heated sample gas line to the analyzer.....	27
	5.4.3	Installing the stainless steel screw fitting.....	27
	5.4.4	Using a push-in fitting (pneumatic).....	28
	5.4.5	Laying the hose bundle line.....	28
	5.4.6	Setting the pressure reducer module.....	29
	5.4.7	Connecting the valve block.....	30
	5.4.8	Connecting the span gases.....	31
	5.4.9	Connecting the exhaust gas outlet.....	32
6		Electrical installation.....	34
	6.1	Safety.....	34
	6.2	Equipment protection.....	34
	6.3	Disconnecting device.....	34
	6.4	Socket for Service work.....	34
	6.5	Connecting the voltage supply.....	34
	6.6	Performing a high voltage test.....	35
	6.7	Connecting the signal line (option).....	35
	6.8	Connecting Ethernet (option).....	36
7		Commissioning.....	37
	7.1	Prerequisites for switching on.....	37
	7.2	Switching on.....	37
	7.3	Recognizing the safe operating state.....	37
	7.4	Adjusting.....	37
	7.4.1	Performing zero point adjustment.....	37
	7.4.2	Performing reference point adjustment.....	38
	7.4.2.1	Adjustment with internal adjustment filter.....	38
	7.4.2.2	Adjustment with span gas.....	38
	7.4.2.3	O ₂ adjustment.....	39
8		Operation.....	40
	8.1	Operating concept.....	40
	8.2	User groups.....	40
	8.3	Display.....	40
	8.4	Tiles.....	41
	8.5	Measuring Screen.....	42
9		Menus.....	44
	9.1	Password.....	44
	9.2	Menu tree.....	44
10		Maintenance.....	49
	10.1	Safety.....	49
	10.2	Cleaning.....	50
	10.2.1	Cleaning surfaces and parts with media contact.....	50
	10.2.2	Cleaning the display.....	51

10.3	Maintenance plan.....	51
10.4	Checking the system.....	52
10.4.1	Check assemblies.....	52
10.4.2	Check external instrument air supply.....	52
10.4.3	Check span gases.....	53
10.4.4	Check environment.....	53
10.4.5	Check gas sampling unit.....	53
10.4.6	Performing the leak tightness check.....	53
10.4.7	Check measured values (when system in operation).....	53
10.5	Maintaining the instrument air conditioning.....	53
10.5.1	Maintaining the instrument air conditioning (option).....	53
10.5.2	Maintaining the external instrument air conditioning (option).....	54
10.6	Replacing the filter pad.....	54
11	Troubleshooting.....	57
11.1	Safety.....	57
11.2	Error messages and possible causes.....	58
11.3	Replacing the Electronics module filter pad.....	63
12	Decommissioning.....	64
12.1	Switching off.....	64
12.1.1	Switching off.....	64
12.1.2	Shutdown.....	64
12.2	Return delivery.....	64
12.2.1	Shipping for repair.....	64
12.2.2	Cleaning the device before returning.....	65
12.3	Transport.....	65
12.4	Disposal.....	65
13	Technical data.....	67
13.1	Dimensional drawings.....	67
13.2	Technical data.....	69
13.2.1	Measured values.....	69
13.2.2	Ambient conditions.....	70
13.2.3	Housing.....	71
13.2.4	Interfaces and protocols.....	71
13.2.5	Power supply.....	71
13.2.6	Gas supply.....	72
13.2.7	Tube connections.....	72
13.2.8	Sample gas conditions.....	73
13.2.9	Connections in analyzer.....	73
13.2.9.1	Voltage supply - connection / fuses.....	73
13.2.9.2	Electronics fuses.....	73
13.2.9.3	Connections for heated components.....	74
13.2.9.4	Connections for interfaces and SD card.....	76

13.2.10	Heated sample gas line.....	78
13.2.11	Switching on the circuit breakers again.....	78
13.2.12	Torques for screw fittings.....	78
14	Annex.....	80
14.1	Conformities.....	80
14.2	Licenses.....	80
14.2.1	Liability disclaimer.....	80
14.2.2	Software licences.....	80
14.2.3	Source codes.....	80

1 About this document

1.1 Function of this document

These Operating Instructions describe:

- Device components
- Mounting and electrical installation
- Commissioning
- Operation
- Maintenance work required for reliable operation
- Troubleshooting
- Decommissioning

1.2 Scope of application

These Operating Instructions are only applicable for the measuring device described in the product identification.

They are not applicable for other Endress+Hauser measuring devices.

The standards referred to in these Operating Instructions are to be observed in the respective valid version.

1.3 Target groups

This Manual is intended for persons who install, commission, operate and maintain the device.

1.4 Further information

The following information is included in the project documentation:

- Gas Sampling Unit Operating Instructions
- Sample Gas Line Operating Instructions
- Smart Service Gateway Operating Instructions
- System Documentation
- Option: Instrument Air Conditioning Operating Instructions
- Option: MPR (Meeting Point Router) Operating Instructions
- Option: GMS800 FIDOR / FIDORi Operating Instructions
- Option: Condensate Container Operating Instructions
- Option: Cooling Unit Operating Instructions

1.5 Symbols and document conventions

The following symbols and conventions are used in this document

Warnings and other notes



DANGER

Indicates a situation presenting imminent danger, which will lead to death or serious injuries if not prevented.



WARNING

Indicates a situation presenting possible danger, which may lead to death or serious injuries if not prevented.



CAUTION

Indicates a situation presenting possible danger, which may lead to moderate or minor injuries if not prevented.



NOTICE

Indicates a situation presenting possible danger, which may lead to property damage if not prevented.



NOTE

Highlights useful tips and recommendations as well as information for efficient and trouble-free operation.

Instructions to action

- ▶ The arrow denotes instructions to action.
- 1. The sequence of instructions is numbered.
- 2. Follow the order in which the numbered instructions are given.
- ✓ The tick denotes the results of an action.

1.5.1 Warning symbols

Table 1: Warning symbols

Symbol	Significance
	Hazard (general)
	Hazard by electrical voltage
	Hazard by acidic substances
	Hazard by toxic substances
	Hazard through hot surface
	Hazard for the environment/nature/organic life

1.5.2 Information symbols

Table 2: Information symbols

Symbol	Significance
	Important technical information for this product
	Important information for electrical or electronic functions

1.6 Data integrity

Endress+Hauser uses standardized data interfaces, such as standard IP technology, in its products. The focus here is on product availability and features.

Endress+Hauser always assumes that the customer is responsible for the integrity and confidentiality of data and rights involved in connection with using the products.

In all cases, the customer is responsible for the implementation of safety measures suitable for the respective situation, e.g., network separation, firewalls, virus protection and Patch Management.

2 Safety information

2.1 Basic safety information

- ▶ Read and observe these Operating Instructions.
- ▶ Observe all safety information.
- ▶ If anything is not clear: Please contact Endress+Hauser Customer Service.

Retention of documents

These Operating Instructions

- ▶ Must be available for reference.
- ▶ Must be passed on to new owners.

Correct project planning

- Basis of this Manual is the delivery of the measuring device according to the preceding project planning (e.g., based on the Endress+Hauser application questionnaire) and the relevant delivery state of the measuring device (see delivered System Documentation).
 - ▶ If you are not sure whether the measuring device corresponds to the state defined during project planning or to the delivered system documentation: Please contact Endress+Hauser Customer Service.

Correct use

- ▶ Use the device only as described in “Intended use”.
The manufacturer assumes no responsibility for any other use.
- ▶ Carry out the specified maintenance work.
- ▶ Do not carry out any work or repairs on the device that are not described in this Manual.
Do not remove, add or change any components in or on the device unless such changes are officially allowed and specified by the manufacturer.
If you do not observe this:
 - The manufacturer's warranty becomes void.
 - The device could become dangerous.

Special local conditions

In addition to the information in this Manual, follow all local laws, technical rules and company-internal operating and installation directives applicable wherever the device is installed.

2.1.1 Electrical safety

Hazard through electrical shock

There is a risk of electric shock when working on the measuring device with the voltage supply switched on.

- ▶ Before starting work on the measuring device, ensure the power supply can be switched off using a power isolating switch or circuit breaker in accordance with the valid standard.
- ▶ Make sure the power isolating switch is easily accessible.
- ▶ An additional disconnecting device is mandatory when the power isolating switch cannot be accessed or only with difficulty after installation of the device connection.

- ▶ Switch off the power supply before carrying out any work on the measuring device.
- ▶ After completion of the work or for test purposes, calibration, the voltage supply may only be activated again by authorized personnel complying with the safety regulations.

Endangerment of electrical safety through power line with incorrect rating

Electrical accidents can occur when the specifications for installation of a power line have not been adequately observed.

- ▶ Always observe the exact specification in the Manual when installing a power cable (see "Technical data", page 67).
- ▶ The user must ensure that the power cable is designed in accordance with the applicable standards.

2.1.2 Dangerous substances

Danger through leaks in the gas path with toxic gases

A leak, e.g., in purge air supply, can represent an acute danger for persons.

- ▶ Regularly check all gas-carrying components for leaks.
- ▶ Take suitable safety measures. E.g.:
 - Marking the measuring device with warning signs.
 - Marking the operating area with warning signs.
 - Ventilating the operating room sufficiently.
 - Safety-related instruction of personnel who could be in the vicinity of the installation site.

Danger through caustic condensate

Health hazard due to toxic compounds in the condensate



- ▶ Observe all safety regulations for the application.
- ▶ Take appropriate protective measures for work (e.g., by wearing a safety mask, protective gloves and acid resistant clothes).
- ▶ In case of contact with the skin or eyes, rinse the affected parts immediately with clear water and consult a doctor.

2.2 Warning information on device

Warning information on device

The following safety symbols are on the device:

Table 3: Warning symbols

Symbol	Significance
	Warning of general hazard
	Warning of hazard by electric voltage, possibly also by residual electric voltage
	Warning of hazard through hot surfaces

If you need to work on an assembly marked with such a symbol:

- ▶ Read the relevant Section in these Operating Instructions
- ▶ Observe all the safety information in the relevant Section

2.3 Intended use

The measuring device is a multicomponent analysis system for continuous flue gas monitoring of industrial combustion plants (emission measuring system). The sample gas is extracted at the measuring point and fed through the analysis system (extractive measurement).

The analysis system is designed for indoor installation.

See the System Documentation delivered for the configuration of your device.

2.4 Requirements on the personnel's qualification

Table 4: Qualification requirements

Tasks	User groups	Qualification
Mounting	Qualified personnel	<ul style="list-style-type: none"> General knowledge in measurement technology, specialist device knowledge (possibly customer training at Endress+Hauser)
Electrical installation	Qualified personnel	<ul style="list-style-type: none"> Authorized electrician (authorized skilled electrician or person with similar training) General knowledge in measurement technology, specialist device knowledge (possibly customer training at Endress+Hauser)
Initial commissioning	Authorized operator ☹	<ul style="list-style-type: none"> General knowledge in measurement technology, specialist device knowledge (possibly customer training at Endress+Hauser)
Recommissioning		
Decommissioning	<ul style="list-style-type: none"> Operator / system integrator Authorized operator ☹ 	<ul style="list-style-type: none"> General knowledge in measurement technology, specialist device knowledge (possibly customer training at Endress+Hauser) Authorized electrician (authorized skilled electrician or person with similar training) Service training
Operation		
Troubleshooting		
Maintenance	<ul style="list-style-type: none"> Operator / system integrator Authorized operator ☹ 	<ul style="list-style-type: none"> General knowledge in measurement technology, specialist device knowledge (possibly customer training at Endress+Hauser) Service training

3 Product description

3.1 Product identification

Overview

Product name	MCS200HW
Manufacturer	Endress+Hauser SICK GmbH+Co. KG Bergener Ring 27, 01458 Ottendorf-Okrilla, Germany
Type plate	Type plates are located outside on the right of the enclosure. The second type plate states the integrated measuring modules. An additional copy of the type plate can be found on the inside of the cabinet.

Type plates

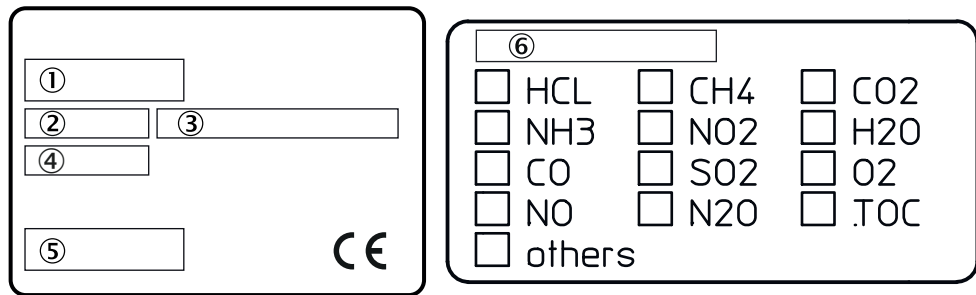

Figure 1: Type plate of complete device, schematic representation

- ① Product name
- ② Item number
- ③ Specification on voltage supply
- ④ Serial number
- ⑤ Barcode
- ⑥ Measuring modules

Analyzer type plate

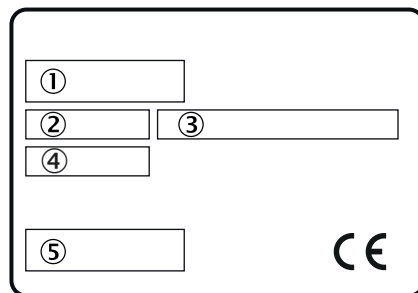

Figure 2: Analyzer type plate, schematic representation

- ① Product name
- ② Item number
- ③ Specification on voltage supply
- ④ Serial number
- ⑤ Barcode

3.2 Gas supply terminology

Definition of utility gases:

- Zero gas: Gas to adjust the zero point. Instrument air or nitrogen (N₂)
- Span gas: Gas to adjust the measuring range full scale value
- Instrument air: Compressed air free of oil, water and particles

3.3 Layout and function

3.3.1 System overview

Overview

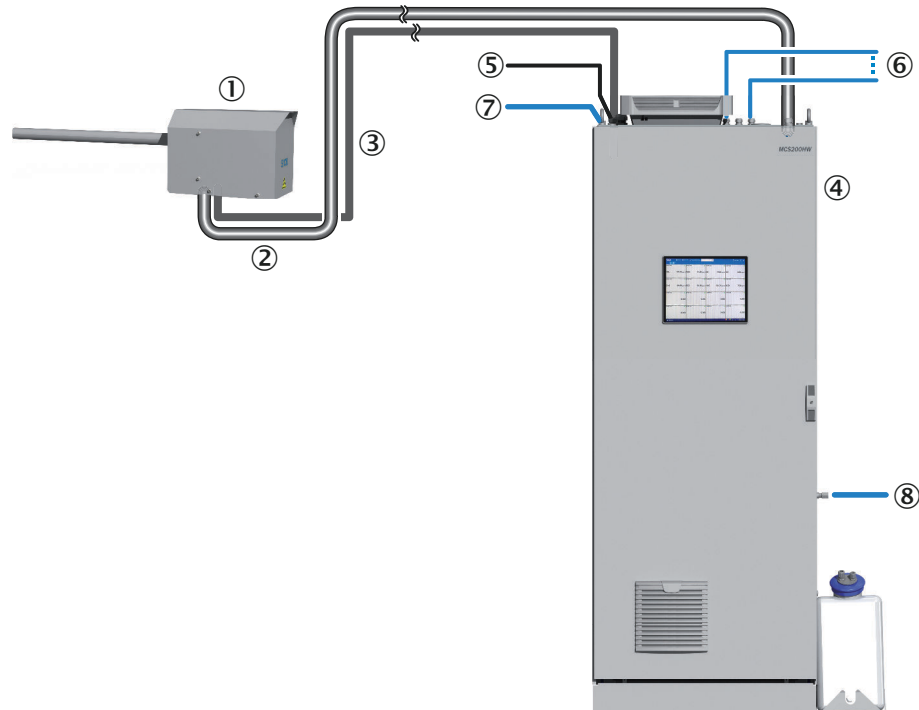

①	Gas sampling unit	
②	Heated sample gas line	
③	Hose bundle line	
④	Analyzer cabinet	
⑤	Voltage supply	
⑥	Interfaces	<ul style="list-style-type: none"> • Customer-specific analog and digital inputs and outputs • 1 x Ethernet: Integration of the system in the customer network / service access • 1 x Ethernet (optional): Smart Service Gateway (SSG) connection
⑦	Instrument air inlet Option: Instrument air conditioning	<p>Observe the quality of the operator's instrument air.</p> <p>A separate instrument air supply can also be connected as zero gas (IR components) or span gas (O₂ sensor).</p>
⑧	Exhaust gas outlet	

Measuring principle

- IR components: Single-beam infrared photometer with interference filter and gas filter correlation method
- Oxygen: Zirconium dioxide sensor

Measuring components

Output of measured values in mg/m^3 or percentage volume, relative to humid flue gas.

It is possible to output measured values in relation to dry sample gas.

Refer to the system documentation provided for the configuration of your system.

Function

- The system operates independently.
- Sampling of flue gas at the measuring point with a heated gas sampling unit
- Sample gas feed to the analyzer in a heated sample gas line
- Heating temperature of all parts with sample gas contact: 200 °C
- Pump: Ejector pump in cell (operated with instrument air)
- The analysis system uses status indicators to signal the current operating state:
- The analysis system switches to operating state “System Stop” automatically when a malfunction occurs
 - “System Stop” corresponds to classification “Failure”:
 - The sample gas line and the sample gas path in the analyzer are automatically purged with instrument air in this mode.
 - Measured values are updated further.

Check (validation) and adjustment

- Zero point adjustment
- Reference point adjustment
- Adjustment with internal adjustment filter

Operating using the display

It is possible to operate the device using the display.

Operation via external PC (optional)

Operator menus and measured value displays are also available on an external PC via the Ethernet connection (with Google Chrome browser and SOPAS Air).

3.3.2 Analyzer cabinet**Overview**

The analyzer cabinet contains:

- Control unit
- Measurement technology
- Analog and digital interfaces

View



Figure 3: Basic configuration of analyzer cabinet

Analyzer module

- ① Cell module
 - Ejector pump
 - Inlet filter
- ② Optics module
- ③ Electronics module

Analyzer cabinet

- ④ Sample gas inlet (heated sample gas line)
- ⑤ Hose bundle line
- ⑥ Valve block
- ⑦ Pressure reducer module
- Notice: Observe the quality of the operator's instrument air.
- ⑧ Sample gas outlet
- ⑨ I/O module

3.3.3 Gas sampling unit

Overview

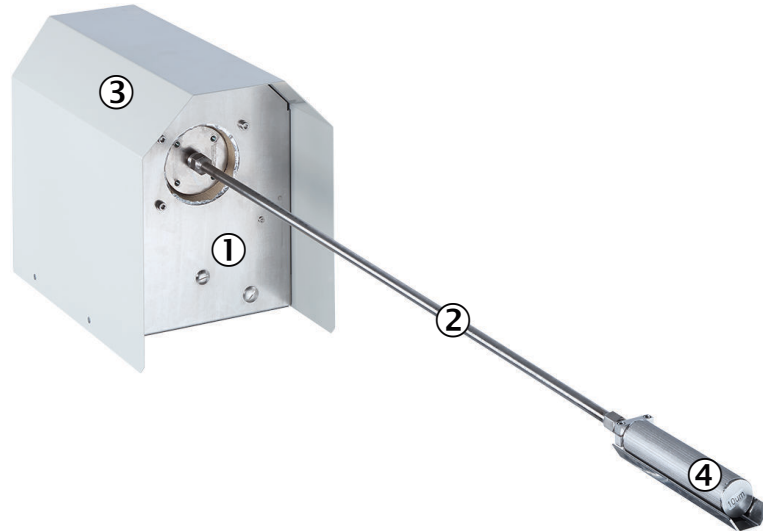

- ① Filter housing
- ② Gas sampling tube (unheated)
- ③ Weather hood
- ④ Pre-filter (optional)

Function

The gas extraction unit extracts flue gas from the stack via the gas sampling tube. After filtration, the flue gas is passed to a measuring device for analysis.

Characteristics

- The gas sampling tube is unheated and without pre-filter
- The gas sampling tube is available in different lengths (option)
- The gas sampling unit is thermostatically controlled.
- The analyzer regulates the heaters.
- When no voltage is applied, the gas sampling unit, heated sample gas line and analyzer are purged with instrument air.

Related topics

- Gas Sampling Unit Operating Instructions

3.3.4 Sample gas line

Overview

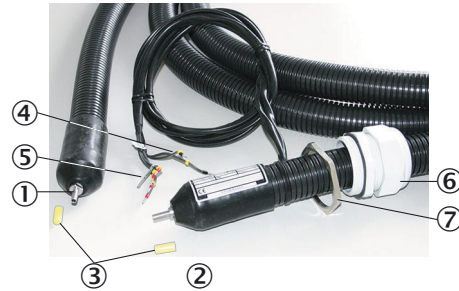

Figure 4: Heated sample gas line

- ① Connection to gas sampling unit (without electrical connections)
- ② Connection to measuring device (with electrical connections)
- ③ Protective cap
- ④ PT100 connections
- ⑤ Power supply
- ⑥ Cable gland
- ⑦ Locknut

Function

The heated sample gas line leads the flue gas from the gas sampling unit to the measuring device.

Characteristics

- The sample gas line is thermostatted to prevent condensation of the flue gas.
- The measuring device regulates the heating.
- When free from voltage, the heated sample gas line is purged with instrument air.

3.3.5 Hose bundle line

Overview

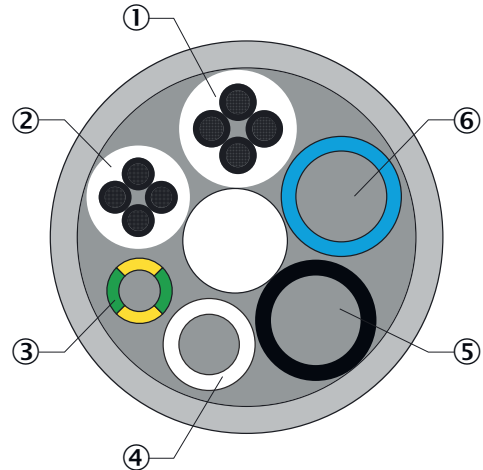

- ① Power supply
- ② Signal line
- ③ Grounding conductor
- ④ PTFE hose, white, DN4/6
- ⑤ PA hose, black, DN6/8, labeled "1"
- ⑥ PA hose, blue, DN6/8, labeled "2"

Function

The hose bundle line connects the gas sampling unit with the measuring device. The hose bundle line contains the power supply line, signal lines and gas lines.

3.3.6 Instrument air conditioning

Overview

If the supplied instrument air does not meet the required quality, an instrument air conditioner must be connected upstream from the pressure reducer module.

Important information



NOTICE

Malfunction of the measuring device due to unsuitable instrument air
 Operation with air not satisfying the specifications voids the warranty and does not ensure proper functioning of the measuring device.

- ▶ Only feed conditioned instrument air to the measuring device.
- ▶ The instrument air quality must meet the specification.

Function

The instrument air conditioning serves to condition the compressed air provided by the operator.

Additional information

A separate instrument air supply as zero gas or span gas can be connected as an alternative.

Related topics

- Instrument Air Conditioning Operating Instructions
- Instrument air quality: see "Gas supply", page 72

3.3.7 Integrated GMS811 FIDORi (option)

As an option, the device can be equipped with an integrated GMS811 FIDORi for measuring the total carbon (TOC). Measured values and operating states can be displayed using the display.

If the GMS811 FIDORi is integrated, it is stated as "TOC" module on the type plate .

Additional information

- GMS800 FIDOR / FIDORi Operating Instructions

3.3.8.1 Cooling unit (option)

The analyzer can optionally be operated with a cooling unit. This extends the temperature range to +5 °C ... +50 °C.

Additional information

- Cooling Unit Operating Instructions

3.4 Extended interfaces (option)

As standard, analog and digital signals are used for device communication with customer peripherals. Alternatively, output can be performed using the Modbus-TCP protocol.

Optionally, Endress+Hauser offers various converter modules that are installed by the customer and communicate with the device via Modbus® TCP.

Optionally available

- PROFIBUS / PROFINET

Modbus

Modbus® is a communication standard for digital controls to create a connection between a »Master« device and several »Slave« devices. The Modbus protocol defines the communication commands only but not their electronic transfer; therefore it can be used with different digital interfaces (Ethernet).

The measuring device is equipped with a digital interface for data transmission in accordance with Guideline VDI 4201, Sheet 1 (General requirements) and Sheet 3 (Specific requirements for Modbus). Refer to the documentation delivered (Modbus signal list) for assignment of the Modbus registers. Only Endress+Hauser Service may perform parameter settings.

3.5 Remote maintenance (option)

Prerequisites

- An internet connection must be available.

Function

- The Endress+Hauser Meeting Point Router (MPR) is available for remote diagnostics via the internet.
- The MPR links a plant-side machine network with the Endress+Hauser remote architecture.
- A firewall which decouples the machine network from the internet or the operating company network is integrated in the MPR.

Related topics

- MPR Meeting Point Router Operating Instructions

4 Transport and storage

4.1 Transport

Overview

Transport and install the device with suitable hoisting equipment (e.g. a crane or jack lift with adequate lifting capacity).

Important information



NOTICE

The measuring device may only be transported and installed by qualified persons who, based on their training and knowledge as well as knowledge of the relevant regulations, can assess the tasks given and recognize the dangers involved.

Transport via crane

Analyzer cabinets are transported safely with delivered lifting lugs. The following permissible total loads apply for symmetrical loads:

- For 45° cable pull angle 4 800 N
- For 60° cable pull angle 6 400 N
- For 90° cable pull angle 13 600 N

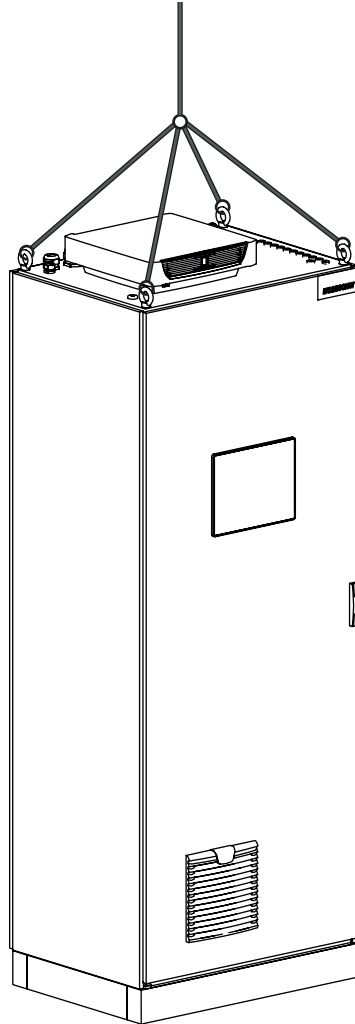

Figure 5: Analyzer cabinet suspension

4.2 Storage

Protective measures for long-term storage

- When gas lines have been unscrewed: Close all gas connections (with sealing plugs) to protect internal gas paths against moisture, dust or dirt penetrating
- Close off open electrical connections dust-tight
- Protect the display against sharp-edged objects. Possibly attach a suitable protective cover (e.g. made of cardboard or hard foam)
- Select a dry, well-ventilated room for storage
- Wrap the device (e.g. with stretch foil)
- When high air humidity can be expected: Include a drying agent (Silica-Gel) in the packing

5 Mounting

5.1 Safety

Qualification

The measuring device may only be installed by trained specialists.

5.2 Scope of delivery

Please see the delivery documents for the scope of delivery.

5.3 Overview of mechanical and electrical installation

Important information



NOTICE

Observe the order of assembly.

If the assembly sequence is incorrect, there is a risk of contamination of the gas sampling unit. This can cause exhaust gas to enter the unheated analyzer and condense out.

- ▶ First connect instrument air and voltage supply.
 - ▶ Only then install the gas sampling unit in the flue gas duct.
-

Installation sequence

- Install the analyzer cabinet
- Electrical connections on analyzer
- Connect the signal lines on the analyzer
- Fit the gas sampling unit
- Connect the heater hose
- Air and gas connections on analyzer
- Connect the sample gas line to the analyzer
- Sample gas outlet

5.4 Installation sequence

5.4.1 Mounting at target location

Overview

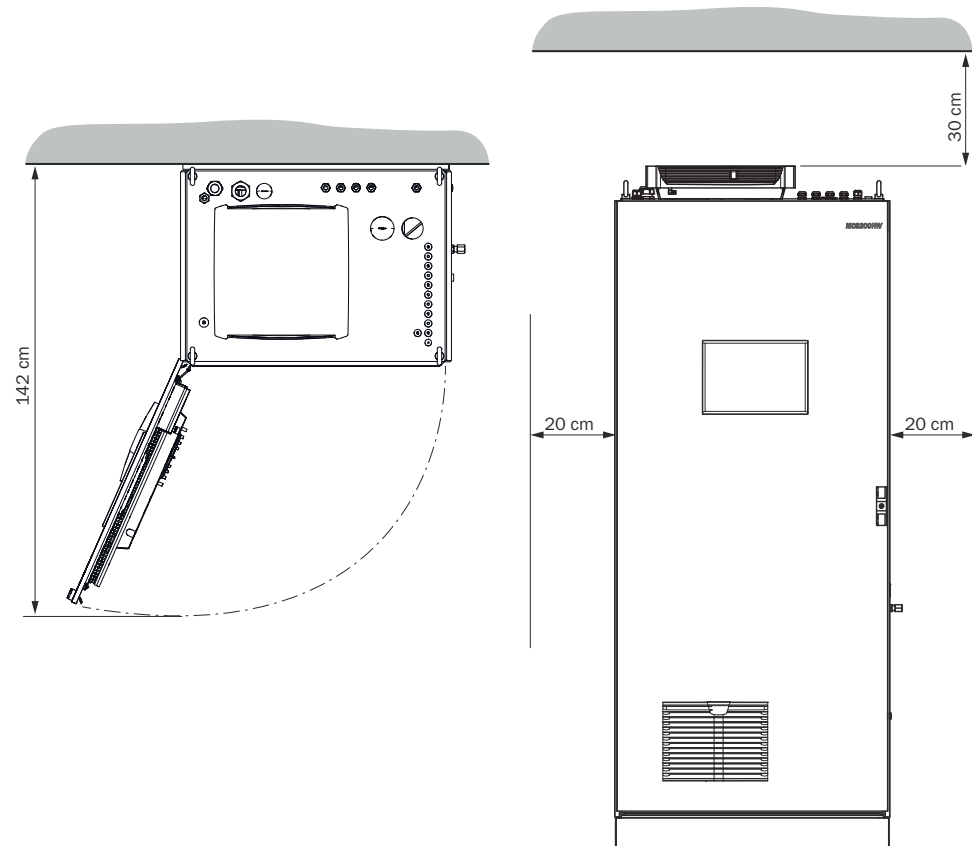

Figure 6: Representation for basic configuration

Prerequisites

- Adequate clearances for the heated sample gas line.
- The installation location is a well ventilated room
- Adherence to the temperature conditions according to the specification
- Adherence to the ambient conditions

Procedure

1. Install the analyzer cabinet on a ground with sufficient load capacity.
2. Install the analyzer cabinet horizontally.
3. Remove the cover from the base.
4. Fasten the analyzer cabinet using 4x M10 screw connections (to the ground).

Related topics

- Ambient conditions: [see "Ambient conditions", page 70](#)

5.4.2 Installing the sample gas line

5.4.2.1 Laying the sample gas lines

Overview

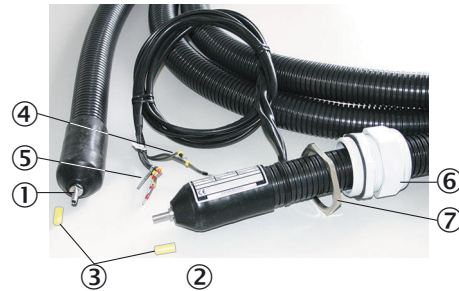

Figure 7: Heated sample gas line

- ① Connection to gas sampling unit (without electrical connections)
- ② Connection to measuring device (with electrical connections)
- ③ Protective cap
- ④ PT100 connections
- ⑤ Power supply
- ⑥ Cable gland
- ⑦ Locknut

Important information



NOTICE

Protect the line from damage (chafing through vibration, mechanical load).



NOTICE

The sample gas line must not be insulated at the position of the Pt100 or led through a wall, as otherwise the sample gas line may be damaged.

Procedure

1. Lay the end **with** the electrical connection to the measuring device.
 - ⓘ **NOTICE** | The screw connection for the enclosure duct must be located at the same end as the electrical connection (measuring device side).
2. Lay the end **without** the electrical connection to the gas sampling unit.
3. Observe a minimum bending radius of 260 mm.

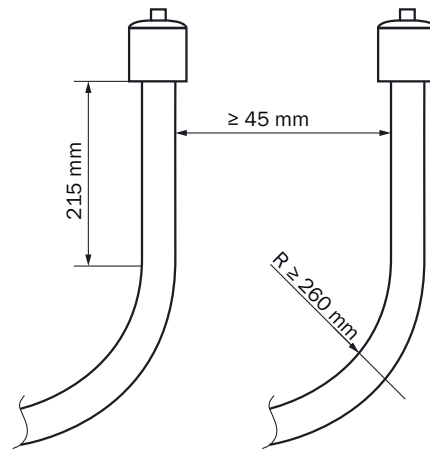

Figure 8: Lines – clearance and bending radius

4. Roll up excess length at the gas sampling unit. Leave enough length for pulling the gas sampling unit.
5. Fasten the sample gas line accordingly (e.g. on cable trays).

5.4.2.2 Connecting the heated sample gas line to the analyzer

Procedure

1. Unscrew the counter nut from the cable gland. Remove from sample gas line.
2. Feed the sample gas line together with the electrical connections from above through the enclosure opening in the analyzer cabinet roof.
3. Push the counter nut back over the sample gas line and the electrical connections.
4. Screw the counter nut tight on the cable gland.
5. Unscrew the cell cover and remove.
6. Remove the protective cap from the sample gas line.
7. Insert the sample gas line to the stop in the clamping ring screw connection on the cell.
8. Screw the sample gas line tight on the clamping ring screw connection.
9. Attach red foam insulation to the clamping ring screw connection. Bind together with a cable clip. No thermal bridges may remain.
10. Close the cell again.
11. Screw cable gland tight.
12. Push electric lines downwards through the cable duct.
13. Connect the voltage supply of the sample gas line.

5.4.3 Installing the stainless steel screw fitting

Overview

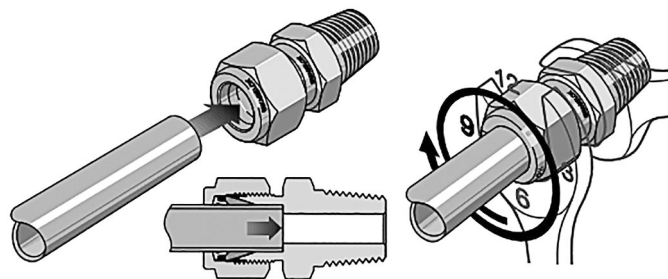

Figure 9: Stainless steel screw fitting

Procedure

1. Push the hose into the tube screw fitting to the stop.
2. During initial fitting: Hold the fitting bolt steady and tighten the cap nut with 1 1/4 revolutions.
3. During refitting: Tighten the cap nut to the previous position (the resistance increases noticeably) and then tighten slightly.

5.4.4 Using a push-in fitting (pneumatic)

Overview

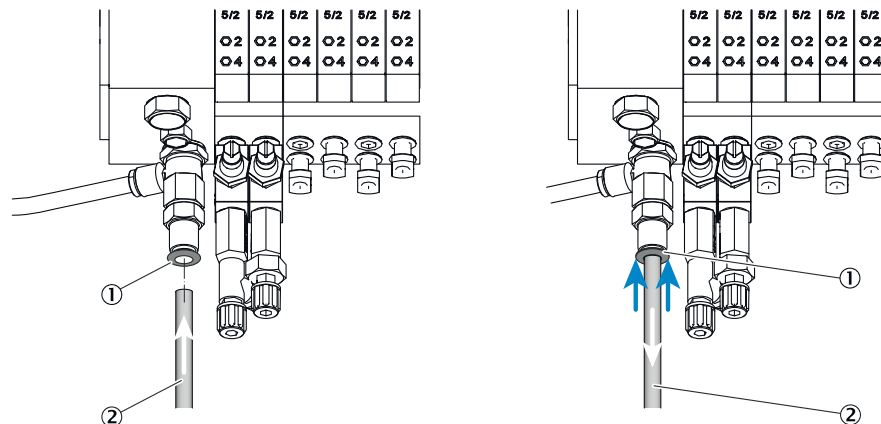

Figure 10: Push-in fitting with retaining ring (example shown)

- ① Retaining ring
- ② Tube

Procedure

Fitting the tube

1. Push the tube in.

Removing the tube

1. Press the retaining ring in.
2. Pull the tube out.

5.4.5 Laying the hose bundle line

Important information



DANGER

There is a risk of explosion when electrical devices and lines without explosion protection are installed outside the pressurized analyzer cabinet.

- ▶ The hose bundle line must be inserted into the gas sampling unit via the explosion-proof terminal box provided for this purpose and all connections must be made inside this terminal box.
- ▶ Then close the cable entry tightly and screw the cover of the terminal box back on tightly.
- ▶ On the other side, the hose bundle line must be led into the pressurized enclosure and all connections must be made inside the pressurized enclosure.



NOTICE

Protect the line from damage (chafing through vibration, mechanical load).

Procedure

1. Lay the hose bundle line from the gas sampling unit to the measuring device.
 - An additional length of 2 m is required at the gas sampling unit for the internal lines.
 - An additional length of 1.5 m is required as from the enclosure inlet of the measuring device for the internal lines.
2. Observe a minimum bending radius of 300 mm.

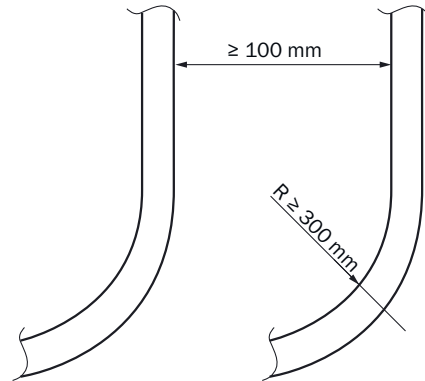

Figure 11: Lines – clearance and bending radius

3. Fasten the hose bundle line accordingly (e.g. on cable trays).

5.4.6 Setting the pressure reducer module

Overview

The external air supply is fitted on the pressure reducer module.

The instrument air is used as both induction air for the ejector (cell) and zero/control air.

There are two possibilities of connecting instrument air:

- One (1) shared instrument air supply for ejector air and zero/control air (inlet 1)
- Separate instrument air supply for:
 - Ejector air (inlet 2)
 - and zero/control air (inlet 1)

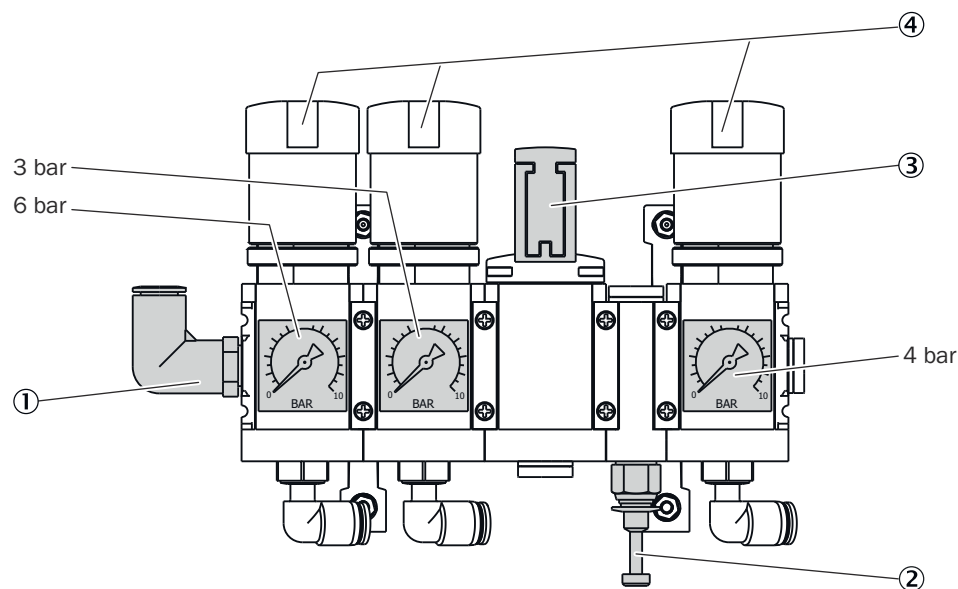

- ① Inlet of instrument air with zero gas quality
- ② Inlet of instrument air solely as induction air for ejector
- ③ Manual valve for instrument air selection (closed position)
- ④ Pressure reducer (adjustable)

Important information



NOTE INSTRUMENT AIR QUALITY

The quality requirement for instrument air used exclusively as ejector air is lower than for usage as zero/control air (zero gas quality).

Procedure

Connection of shared instrument air supply

1. Connect instrument air with zero gas quality on inlet 1.
2. Set manual valve to position "open".

Connection of separate instrument air supply

1. Connect instrument air supply with zero gas quality on inlet 1.
2. Connect instrument air supply for ejector on inlet 2.
3. Set manual valve to position "closed".

Related topics

- Requirements for instrument air quality: [see "Gas supply", page 72](#)

5.4.7 Connecting the valve block

Overview

The following are located on the valve block

- Gas connections of the gas sampling unit hose bundle line

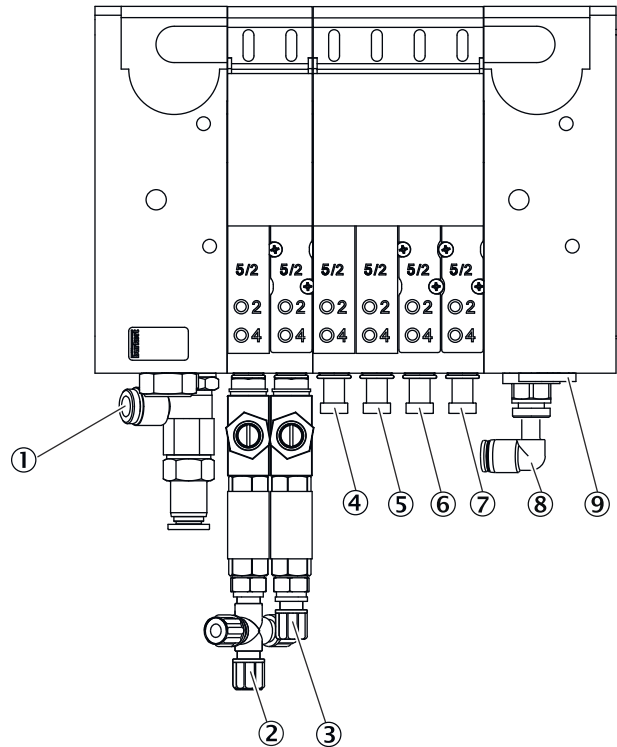

- ① Inlet: Zero gas
- ② Outlet: Zero gas measuring point 1
- ③ Outlet: Zero gas measuring point 2 (option)
- ④ Outlet: Control air measuring point 1
- ⑤ Outlet: Backflush air measuring point 1
- ⑥ Outlet: Control air measuring point 2 (option)
- ⑦ Outlet: Backflush air measuring point 2 (option)
- ⑧ Inlet: Control/backflush air
- ⑨ Inlet: Auxiliary control air

Important information



WARNING

Hazard when pressure is too high
Hoses can burst when the pressure is too high.

- The maximum permissible operating pressures must not be exceeded.

Related topics

- Specification of the pressures to be used: see ["Gas supply", page 72](#)

5.4.8 Connecting the span gases

Overview

The span gases are connected to the span gas unit.

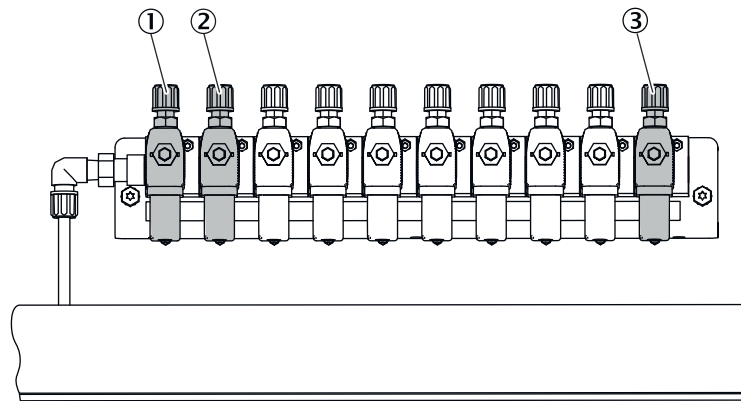

Figure 12: Span gas unit connections

- ① Span gas connection 1
- ② Span gas connection 2
- ③ Instrument air to purge the span gas valve

The Figure serves as example. It is also possible to connect more than two span gas valves.

Prerequisites

- The span gases are switched off.

Procedure

1. Lead the span gas lines through the roof into the enclosure.
2. Connect the span gas lines to the span gas unit.
3. Open the span gas cylinder and set the pressure to approx. 3.5 bar.
4. Check the lines for leak tightness.

5.4.9 Connecting the exhaust gas outlet

Important information



WARNING

Noxious and aggressive exhaust gases

The exhaust gases may contain harmful or irritating components.

- ▶ Lead the measuring system gas outlets outdoors or into a suitable flue.
- ▶ Do not connect the exhaust gas line with the exhaust gas line of sensitive subassemblies. Aggressive gases could damage these subassemblies as a result of diffusions.



NOTICE

Condensate could accrue in the exhaust gas line.

- ▶ Use a suitable hose line to run the condensate outlet into an open condensate container or a waste disposal line.
- ▶ Lay the line so that it always runs downwards.
- ▶ Keep the line opening free from any blockages or liquids.
- ▶ Protect the line from frost.

**NOTICE**

Discharging the exhaust gas under pressure can cause equipment damage.

- ▶ Discharge exhaust gases without pressure.
-

Procedure

1. Connect the exhaust gas outlet at the intended place.
2. Lay the exhaust gas line in a suitable manner:
 - The gas outlet must be open to the ambient pressure; in waste disposal lines it can be laid with a light partial vacuum.
 - Do not bend or crimp exhaust gas lines.

6 Electrical installation

6.1 Safety

Qualification

The measuring device may only be installed by trained specialists.

6.2 Equipment protection

Short-circuit protection must be provided by the customer in accordance with the applicable standards by means of fuses or circuit breakers with short-circuit protection and overload protection.

6.3 Disconnecting device

Install a power isolating switch or circuit breaker according to the valid standard for disconnecting the voltage supply.

Install an additional disconnecting device if a UPS is used.

Make sure the power isolating switches are easily accessible.

6.4 Socket for Service work

It is recommended to install a socket in accordance with the applicable standards near the measuring device for service work.

6.5 Connecting the voltage supply

Overview

The voltage supply is located on the left on the analyzer.

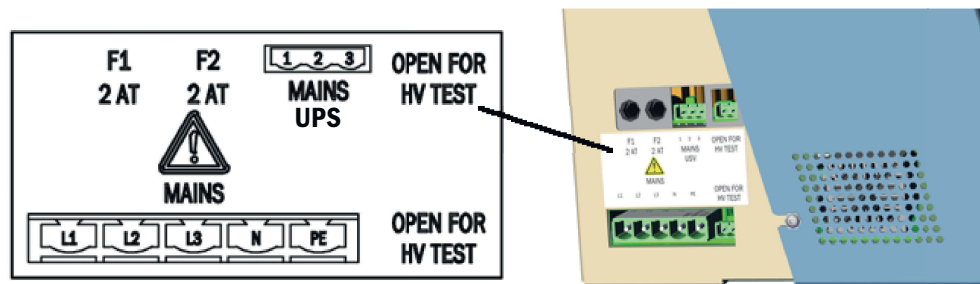

Figure 13: Voltage supply connection

As an option, the system can be supplied with voltage by a UPS. Refer to the delivered wiring diagram for information on how to install it.

Install an additional disconnecting device if a UPS is used.

Important information**NOTICE**

- Install an external power disconnection unit which disconnects all connectors and fuses near the analyzer.
- The power disconnection unit must be marked clearly and be easily accessible.
- The onsite wiring system to the power source of the system must be installed and fused according to the relevant regulations.
- Always connect a protective ground to PE.

Procedure

1. Guide the electric lines through the screw connections of the enclosure.
2. Connect the electric lines.

6.6 Performing a high voltage test**Overview**

Figure 14: Voltage supply connections

Procedure

1. To avoid erroneous measurements during a high-voltage test, the bridges described in Figure see figure 14, page 35 must be removed.
2. Insert the bridges again after the high-voltage test.

6.7 Connecting the signal line (option)**Overview**

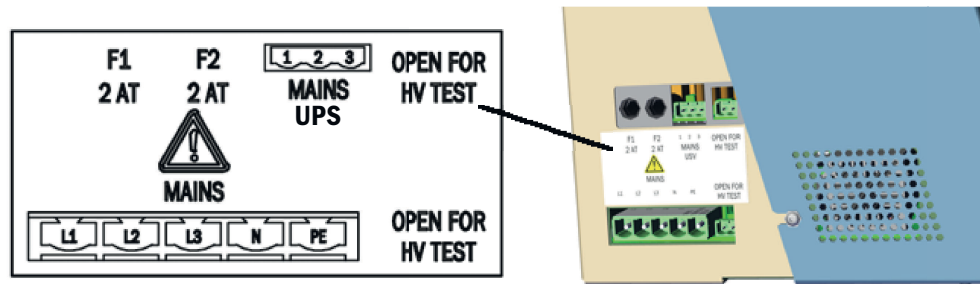
Figure 15: Signal lines connections (shielded)

Connect the signal lines according to the wiring diagram.

Procedure

1. Guide the line through the enclosure duct.
2. Attach the shielding according to the Figure,

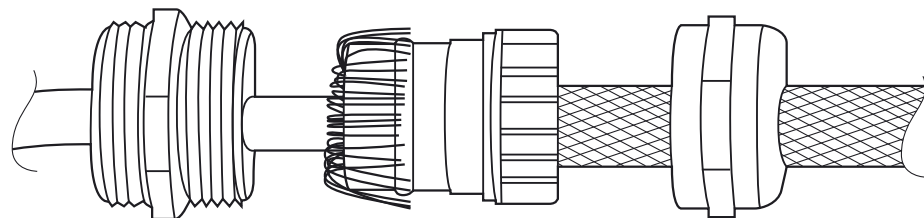
6.8 Connecting Ethernet (option)

Overview

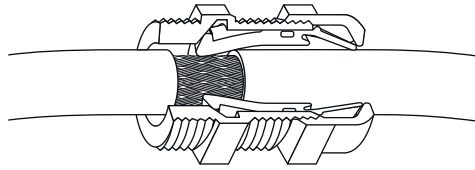

Figure 16: Ethernet connection

Connect the Ethernet cable according to the wiring diagram.

Procedure

1. Guide the Ethernet cable through the Ethernet cable gland into the enclosure.
2. Establish a safe contact between the signal cable shield and the cable gland.

7 Commissioning

7.1 Prerequisites for switching on

Procedure

1. Check the measuring device.
2. Instrument air must be connected and open.
3. If the instrument air has changed: Check the instrument air quality.
4. Check pressure settings on the pressure reducer unit.

Related topics

- Measuring device check: [see "Checking the system", page 52](#)
- Instrument air quality: [see "Gas supply", page 72](#)
- Pressure reducer unit setting: [see "Setting the pressure reducer module", page 29](#)

7.2 Switching on

Procedure

1. Ensure that all power isolating switches on the outer wall of the pressurized enclosure are turned off.
2. Switch on the on-site voltage supply.
 - ✓ SOPASair loading screen is displayed.
 - ✓ A countdown is shown on the display, counting down from 80.
 - ✓ The start screen opens. Display: System initialization
 - ✓ The measuring device heats up: Display: System heats. The status indicator is orange. Heating process can take up to 2 hours.
 - ✓ Display: Premeasure. The status indicator is orange.
 - ✓ The status indicator is green. Display: Measure. The measuring device is ready for operation.
3. When the yellow or red status indicator is on: Display logbook and clear error.
 - ✓ The measuring device is in operation.

Related topics

- Error list: [see "Error messages and possible causes", page 58](#)

7.3 Recognizing the safe operating state

The system is in proper operation when:

- A system check has been carried out according to the Maintenance plan before commissioning and in running operation.
- Only the green status indicator is on and Measuring is shown in the status bar. When the yellow or red status indicator is on: Display logbook and clear error.

Related topics

- Checking the system: [see "Checking the system", page 52](#)
- Error list: [see "Error messages and possible causes", page 58](#)

7.4 Adjusting

7.4.1 Performing zero point adjustment

Overview

Menu: Tasks →Zero point adjustment

As standard, the zero point adjustment is used to adjust the zero points of the measured values while instrument air is fed.

Zero point adjustment runs cyclically (preset) but can also be started manually.

If the deviation is higher than a specified limit value, the system switches to classification "Maintenance request" and the zero point is however corrected.

Procedure

1. Click tile "Zero point adjustment".
 - ✓ The operating state switches to zero point adjustment.
 - ✓ The respective active step is displayed.
 - ✓ The time elapsed and the remaining time of the state and of the respective active step is displayed.
2. The system switches back to original state automatically when adjustment has been completed.

7.4.2 Performing reference point adjustment

7.4.2.1 Adjustment with internal adjustment filter

Overview

Menu: Tasks → Adjustment with internal adjustment filter

During adjustment, concentrations of measuring components are adjusted with an adjustment filter.

Procedure

1. Click tile "Adjustment with internal adjustment filter".
 - ✓ The operating state switches to adjustment with internal adjustment filter.
 - ✓ The respective active step is displayed.
 - ✓ The time elapsed and the remaining time of the state and of the respective active step is displayed.
2. The system switches back to original state automatically when adjustment has been completed.

7.4.2.2 Adjustment with span gas

Overview

Menu: Tasks → Reference point adjustment

During adjustment, the concentrations of the respective measuring component are adjusted using span gas.

Procedure

1. Compare the span gas concentration set with the certificate of the span gas cylinder and, when necessary, change it in the device: Tasks → Reference point adjustment - Concentrations.
2. Perform manual update.
3. Use the arrow button to go to the next Figure.
4. Start adjustment with "Reference point adjustment".
 - ✓ The operating state switches to reference point adjustment.
 - ✓ The time elapsed and the remaining time of the state and of the respective active step is displayed.
5. The system switches back to original state automatically when adjustment has been completed.

7.4.2.3 O₂ adjustment

Overview

Menu: 2 adjustment → 1 adjustment → O2 adjustment

During adjustment, the concentrations of the respective measuring component are adjusted using instrument air as standard.

Procedure

1. Start adjustment with "O2 adjustment".
 - ✓ The operating state switches to O2 adjustment.
 - ✓ The time elapsed and the remaining time of the state and of the respective active step is displayed.
2. The system switches back to original state automatically when adjustment has been completed.

8 Operation

8.1 Operating concept

Operation

The analysis system is equipped with a display with touchscreen.

- All menus and functions are shown on the display.
- The menus and functions are called up using the tiles.
- The current operating state is displayed by the status indicator (Namur).

8.2 User groups

Depending on the user group, different menus are visible on the device.

User group	Task
Operator	System monitoring regarding measured values and status
Authorized client	Configuration, simple error clearance and maintenance

8.3 Display





Overview













- ① Quick access
- ② Search box
- ③ Editing and updating tools
- ④ Display and selection screen
- ⑤ Display of time and date
- ⑥ Status indicator (Namur)
- ⑦ Display of operating state
- ⑧ Display of user
- ⑨ Display of menu path

Significance of status indicator (Namur)

Color	Status signal	Significance
■	Normal	Valid output signal

Color	Status signal	Significance
	Maintenance request	Maintenance necessary, valid output signal
	Outside specification	Signal outside specified range
	Function check	Sporadically no valid output signal
	Failure	No valid output signal

8.4 Tiles

Symbol	Name	Function
	Login symbol	Calls up the Login menu.
	Menu symbol	Calls up the menu.
	Home symbol	Goes back to start screen (measured value overview).
	Quick access to tasks	Calls up the task menu where the most important functions for the operator are contained.
	Quick access to logbook	Calls up the device logbook.
	Quick access to Measuring Screen	Selection of saved Measuring Screens using a drop-down menu.
	Search box	Enter a search term to call up the relevant display.
	History	Selection of the last six displayed pages using a drop-down menu.
	Refresh	Reloads the called up page.
	Edit	Activates editing on the input pages.

8.5 Measuring Screen

Overview

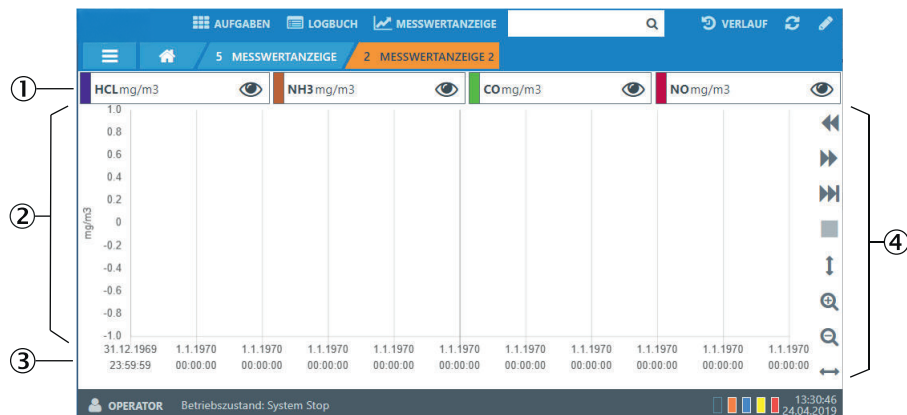











Figure 17: Measuring Screen

- ① Legend of displayed measured values
- ② Measured value concentration
- ③ Measuring time and date
- ④ Tiles

Measuring Screen tiles

Symbol	Name	Function
	Visibility	Switches the visibility of the measured value curve on and off.
	Move left	Shifts the time axis of the measured value curve.
	Move right	Shifts the time axis of the measured value curve.
	Current value	Jumps to the current measured value of the measured value curve on the time axis.
	Stop	Stops update of measured values.
	Adjust y-axis	Displays the largest preset range of component concentrations of visible components.
	Adjust x-axis	Displays preset range of time.

Symbol	Name	Function
	Increase	Increases display of time axis.
	Reduce	Reduces display of time axis.

9 Menus

9.1 Password

Configuration is only possible on level “Authorized Client”. Login is performed using tile “Login” and a password prompt.

Password for “Authorized Client”: HIDE (preset)

9.2 Menu tree

	Menu level	Explanation
1	Tasks	Quick access to the most important functions for the operator
2	Adjustment	
2.1	Adjustment	
2.1.1	Zero point adjustment	The measured value zero points are adjusted while instrument air is fed.
2.1.2	Adjustment with internal adjustment filter	The concentrations of measuring components are adjusted with an adjustment filter.
2.1.3	Reference point adjustment	The concentrations of measuring components are adjusted while span gas is fed.
2.1.4	O2 adjustment	The zero and reference point is adjusted while instrument air is fed.
2.1.5	Pressure adjustment	Adjustment of pressure sensors.
2.2	Validation	
2.2.1	Zero point validation	The measured value zero points are checked while instrument air is fed, but not adjusted.
2.2.2	Validation with internal adjustment filter	The concentrations of measuring components are adjusted with an adjustment filter, but not adjusted.
2.2.3	Reference point validation	The concentrations of measuring components are checked while span gas is fed, but not adjusted.
2.3	Span gas feed	Different reference materials can be controlled. No adjustment or validation is performed.
2.4	Results	
2.4.1	Adjustment factors	Displays the adjustment factors for span gas and adjustment with internal adjustment filter.
2.4.2	Zero point drift	Displays the determined percentage deviation after zero point validation.

2.4.3	Reference point drift (internal adjustment filter)	Displays the determined percentage deviation of measuring component concentration after validation with an adjustment filter.
2.4.4	Reference point drift (span gas)	Displays the determined percentage deviation of measuring component concentration after validation with span gas.
2.5	Settings	
2.5.1	Span gas concentrations	Entry fields for updating the span gas concentrations.
2.5.2	Component-specific parameters	Displays the parameters of the individual measuring components.
2.5.3	Parameters	Displays general parameters and parameters relevant for adjustment.
2.5.4	Cyclic triggers	Displays configured start times of sequences.
3	Diagnosis	
3.1	Status	Displays device information and the current status.
3.2	Logbooks	
3.2.1	Device logbook	Logbook of pending messages and status with start and end date.
3.2.2	Customer protocol	Tile "Edit" allows entries by operator and maintenance personnel.
3.3	Device state data	
3.3.1	Operating hours counter	Displays operating hours.
3.3.2	Temperatures	Displays temperatures and their status.
3.3.3	IR source	Displays IR source status.
3.3.4	Motors	Displays motor values.
3.3.5	Pressure	Displays current pressures.
3.3.6	Flow rate	Displays flow rates and their status.
3.3.7	Hardware monitoring	Displays values and hardware status.
3.3.8	O2 sensor	Displays values and O2 sensor status.
3.3.9	Reference energy	Displays reference energy of the individual measuring components.
3.3.10	Intensity	Displays intensities of measuring filters and reference filters.
3.4	Interfaces	

3.4.1	Analog outputs	Displays current mA of the individual analog outputs.
3.4.2	Analog inputs	Displays current mA of the individual analog inputs.
3.4.3	Digital outputs	Displays digital output status. Digital outputs switched off are marked with “.”, those switched on with “I”.
3.4.4	Digital inputs	Displays digital input status. Digital inputs switched off are marked with “.”, those switched on with “I”.
3.4.5	Modbus outputs	Displays values of the individual Modbus outputs.
3.4.6	Modbus inputs	Displays values of the individual Modbus inputs.
3.5	Signals	
3.5.1	Measuring signals	Displays measuring signals of the measuring components.
3.5.2	Boolean values	
3.5.3	Real values	
3.5.4	Filtered values	
3.5.5	Integer values	
3.5.6	Real constants	
3.6	Diagnosis files	
3.6.1	Export of measured value history	Option for exporting the Measuring Screen history.
4	Parameters	
4.1	Display settings	Tile “Edit” serves to adjust the Measuring Screen layout.
4.1.1	Measuring Screen 1	
4.1.2	Measuring Screen 2	
4.1.3	Measuring Screen 3	
4.1.4	Measuring Screen 4	
4.1.5	Measuring Screen 5	
4.1.6	Measuring Screen 6	
4.1.7	Measuring Screen 7	
4.1.8	Measuring Screen 8	
4.2	Measuring components	Displays definitions of measuring components and monitoring limits.

4.3	Interfaces	Displays information on the different interfaces.
4.3.1	Analog outputs	
4.3.2	Analog inputs	
4.3.3	Digital outputs	
4.3.4	Digital inputs	
4.3.5	Modbus outputs	
4.3.6	Modbus inputs	
4.3.7	Modbus	
4.3.8	OPC outputs	
4.3.9	LAN	
4.3.10	Hardware plan (CAN)	
4.4	Date and time	Set date and time.
4.5	Device information	Displays device information.
5	Measuring Screen	Displays individual preset Measuring Screens.
5.1	Measuring Screen 1	
5.2	Measuring Screen 2	
5.3	Measuring Screen 3	
5.4	Measuring Screen 4	
5.5	Measuring Screen 5	
5.6	Measuring Screen 6	
5.7	Measuring Screen 7	
5.8	Measuring Screen 8	
6	Maintenance	
6.1	Maintenance signal	Switch Maintenance signal on and off.
6.2	Restart	Restart the device.
6.3	Data backup	
6.3.1	Backup	
6.3.2	Restore	
6.4	Protocol	Tile "Edit" allows entries by operator and maintenance personnel.

6.5 Functions

Trigger sequences and states.

- A sequence can be started from any state except standby.
- States must be terminated or changed actively.

6.6 Reset

6.6.1 Confirm active messages

7 Settings

Tile "Edit" serves to make settings.

10 Maintenance

10.1 Safety

Requirements for the maintenance personnel

- Only allow an authorized electrician to work on the electrical system or electrical assemblies.
- The technician must be familiar with the exhaust gas technology of the operator's plant (hazard by overpressure and toxic and hot flue gases) and be able to avoid hazards when working on gas ducts.
- The technician must be familiar with handling compressed gas cylinders (span gases).
- The technician must be able to avoid hazards caused by noxious span gases.
- The technician must be familiar with gas lines and their screw fittings (be able to ensure gas-tight connections).

Electric voltage



DANGER

Danger to life through electric shock

There is a risk of electric shock when working on the device with the voltage supply switched on.

- ▶ Before starting work on the device, ensure the voltage supply can be switched off in accordance with the valid standard using a power isolating switch/circuit breaker.
- ▶ Switch off the voltage supply before starting any work on the device.
- ▶ After completion of the work or for test purposes or calibration, the power supply may only be activated again by authorized personnel complying with the safety regulations.



NOTICE

Risk of destruction of electronic components by electrostatic discharge (ESD)

When electronic assemblies are touched, there is a risk of the assembly being destroyed by electrical equipotential bonding.

- ▶ Make sure you have the same electric potential as the assembly (e.g. by grounding) before touching the assembly.



NOTICE

Observe voltage variant

Some spare parts are available in different voltage variants, 115 V or 230 V.

The power voltage of your system is shown on the type plate.

- ▶ Check spare parts for voltage dependency before fitting:

Sample gases and exhaust gases



CAUTION

Risk of chemical burns by acid gas

Acid condensate could escape when working on the sample gas lines and the associated assemblies.

- ▶ Take appropriate protective measures for work (e.g., by wearing a safety mask, protective gloves and acid resistant clothes)
 - ▶ In case of contact with the eyes, rinse immediately with clear water and consult a doctor.
-



NOTICE

Risk of contamination of analyzer

The gas sampling unit and analyzer are flushed with instrument air when the system is not in measuring operation. When the instrument air is switched off, there is the risk of contamination of the analyzer.

- Pull the gas sampling unit out of the exhaust duct when instrument air is not available for a longer period of time.
-

Surfaces



CAUTION DANGER OF BURNS DUE TO HOT SURFACES

Surface can become hot through operation of the device.

- ▶ Wear suitable protective clothes, for example, heat-resistant gloves.
 - ▶ Switch off the device and allow the components to cool down.
-

Span gases



CAUTION

Before working on span gas cylinders or span gas lines: Relieve the span gas pressure.

- ▶ Shut off the span gas cylinder.
 - ▶ Open the span gas valve: Menu: 2 Adjustment → 3 Span gas feed.
 - ▶ Wait for about 1 minute until the pressure in the lines has been relieved.
 - ▶ Close the span gas valve: Menu: 2 Adjustment → 3 Span gas feed.
-

Please note:

- After working on the gas path: Perform a leak tightness check.
 - After exchanging a span gas cylinder: Check the compliance with the span gas concentration set in the menu: 2 Adjustment → 5 Settings → 1 Concentrations
-

10.2 Cleaning

10.2.1 Cleaning surfaces and parts with media contact

Important information



NOTICE

Device damage through incorrect cleaning.

Incorrect cleaning can lead to device damage.

- Only use recommended cleaning agents.
 - Do not use sharp objects for cleaning.
-

Procedure

1. Remove loose contamination with compressed air.
2. Remove adhering contamination with a mild soap solution and a soft cloth. Ensure the electric parts do not come into contact with liquids.

10.2.2 Cleaning the display**Overview**

The display must be cleaned regularly from the outside to ensure heat dissipation and thus operation.

Important information**NOTICE**

Device damage through incorrect cleaning.
Incorrect cleaning can lead to device damage.

- Only use recommended cleaning agents.
- Do not use sharp objects for cleaning.

Procedure

1. Wipe the surface with a damp soft cloth and wipe again with a dry soft cloth.
2. If the frames are heavily soiled, do not use acidic or abrasive cleaners, as these attack the surface structure. Use neutral soap sud or limescale remover specially suitable for the surface.
3. Use 2-propanol/isopropanol (isomeric alcohol) for disinfection.

10.3 Maintenance plan**Overview**

This Maintenance plan describes the maintenance work specified by the manufacturer.

Perform checks in accordance with the guidelines to be applied by the operator in accordance with the intervals described therein.

Maintenance intervals

Table 5: Maintenance intervals

Interval	Maintenance work	Remark
Quarterly	Gas sampling unit: ▶ Check filter element and seals. ▶ Clean or renew if necessary.	See Gas Sampling Unit Operating Instructions
	Instrument air (option): ▶ Replace filter elements if required.	See Instrument Air Conditioning Operating Instructions
	Note Depending on the system, it may be necessary to perform the following maintenance tasks more frequently:	
	Check the analysis system.	
	Instrument air (option): ▶ Check oil and water. ▶ Clean drains if required. ▶ Clean filter housing if required. ▶ Check pressure.	See Instrument Air Conditioning Operating Instructions
Every 6 months	One filter pad each in the fan and air outlet ▶ Check fine filter and seals. ▶ Clean or renew if necessary.	
	Gas sampling unit: ▶ Replace the filter element and seals.	See Gas Sampling Unit Operating Instructions

Related topics

- Gas Sampling Unit Operating Instructions
- Instrument Air Conditioning Operating Instructions

10.4 Checking the system

10.4.1 Check assemblies

Procedure

1. Check complete measuring system (from sample gas sampling to exhaust gas) for outer damage.
2. Check sample gas outlet for continuity.
3. Check system cabinet for cleanness, dryness and freedom from corrosion.
4. Check grounding conductors are free from corrosion.
5. Check valve block and pressure reducer unit for leak tightness:
 - No permanent hissing noise should be noticeable.
 - Check no air is escaping from the connections, e.g., with leakage spray

10.4.2 Check external instrument air supply

Procedure

1. Check pressure, oil, particle and water content according to the specification.
2. If an external instrument air conditioning is provided: Check condition of filters.

Related topics

- Specification of utility gases: see "Gas supply", page 72
- Filter conditions: See Instrument Air Conditioning Operating Instructions

10.4.3 Check span gases**Procedure**

1. Check use-by date.
2. Check fill level.
3. Check cylinder pressure.
4. Check condition of cylinders.

10.4.4 Check environment**Procedure**

1. Check ventilation of the room when the cabinet is installed in a room.
2. Check ambient conditions of analyzer and gas sampling unit: Temperature, humidity, vibrations

10.4.5 Check gas sampling unit**Procedure**

1. Visually check state from the outside and clean as necessary.
2. Check sample gas line for outside damage.

10.4.6 Performing the leak tightness check**Overview**

During the pressure test, all pipelines and hoses up to the gas appliances must be tested for leaks with an overpressure of 150 mbar using air or helium. The pipelines are considered to be tight when, after temperature compensation, the test pressure does not drop more than $\Delta p < 25$ mbar during the subsequent test period of 10 min.

The tests must be documented.

Prerequisites

- The measuring system has cooled down to ambient temperature.
- The sample gas supply is closed.
- The sample gas outlet is closed.

Procedure

1. Start measurement.
2. Evaluate measurement result.
3. If a leak in gas-carrying lines is detected with a gas detector or with foam-forming agents according to DIN EN 14291, this must be sealed by suitable measures.
4. Document and save the measurement result in the log.

10.4.7 Check measured values (when system in operation)**Procedure**

1. Check display for pending error messages.
2. Check measured values for plausibility.
3. Check external instrument air conditioning (optional).

10.5 Maintaining the instrument air conditioning.**10.5.1 Maintaining the instrument air conditioning (option)****Prerequisites**

- The quality requirements for instrument air are met.

Procedure

1. Switch on the analyzer maintenance signal: Tasks → Maintenance signal on/off
 2. Flush system for 10 minutes in this state.
 3. Close off operator's instrument air supply.
-



NOTICE

The probe tube is not purged when no instrument air is available.

- ▶ Only close off the instrument air supply for a short time (several minutes).
-

4. Perform maintenance on the instrument air conditioning according to the provided manufacturer's instructions.
5. Open instrument air supply again.
6. Switch the maintenance signal off again.

Related topics

10.5.2 Maintaining the external instrument air conditioning (option)

Prerequisites

- The quality requirements for instrument air are met.

Procedure

1. Check the external instrument air conditioning for correct function.

10.6 Replacing the filter pad

10.6.1 Replacing the filter mat of the roof fan grill

Overview

The device is equipped with two different fans with different filter pads.



Figure 18: Fan grill position in basic configuration

- ① Upper fan grill
- ② Lower fan grill

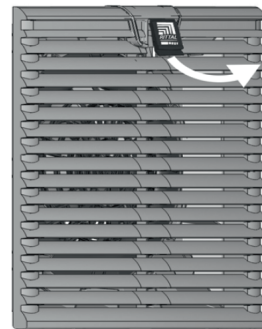

Figure 19: Lower fan grill

Important information



NOTICE

Dirt can get into the measuring device when replacing the filter pad.

- Only replace the filter pad when the measuring device is switched off.

Prerequisites

- The device is switched off.

Procedure

1. Loosen 4 screws on the fan grill (1/4 turn).

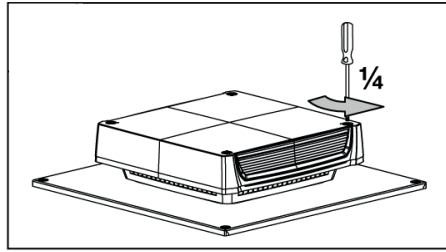

2. Take fan grill off.
3. Replace the filter pads (face in) on all four sides.

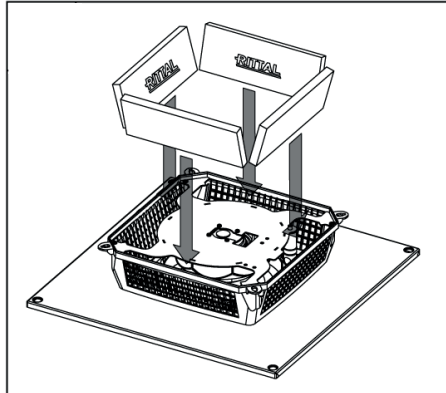

4. Fit the fan grill again and screw tight.

10.6.2 Replacing the filter pad

Important information



NOTICE

Dirt can get into the measuring device when replacing the filter pad.

- ▶ Only replace the filter pad when the measuring device is switched off.

Prerequisites

- Measuring device is switched off.

Procedure

1. Open the cover of the fan.
2. Take filter pad out.
3. Insert new filter pad.
4. Close the cover.

11 Troubleshooting

11.1 Safety

Requirements for the maintenance personnel

- Only allow an authorized electrician to work on the electrical system or electrical assemblies.
- The technician must be familiar with the exhaust gas technology of the operator's plant (hazard by overpressure and toxic and hot flue gases) and be able to avoid hazards when working on gas ducts.
- The technician must be familiar with handling compressed gas cylinders (span gases).
- The technician must be able to avoid hazards caused by noxious span gases.
- The technician must be familiar with gas lines and their screw fittings (be able to ensure gas-tight connections).

Electric voltage



DANGER

Danger to life through electric shock

There is a risk of electric shock when working on the device with the voltage supply switched on.

- ▶ Before starting work on the device, ensure the voltage supply can be switched off in accordance with the valid standard using a power isolating switch/circuit breaker.
- ▶ Switch off the voltage supply before starting any work on the device.
- ▶ After completion of the work or for test purposes or calibration, the power supply may only be activated again by authorized personnel complying with the safety regulations.



NOTICE

Risk of destruction of electronic components by electrostatic discharge (ESD)

When electronic assemblies are touched, there is a risk of the assembly being destroyed by electrical equipotential bonding.

- ▶ Make sure you have the same electric potential as the assembly (e.g. by grounding) before touching the assembly.



NOTICE

Observe voltage variant

Some spare parts are available in different voltage variants, 115 V or 230 V.

The power voltage of your system is shown on the type plate.

- ▶ Check spare parts for voltage dependency before fitting:

Sample gases and exhaust gases



CAUTION

Risk of chemical burns by acid gas

Acid condensate could escape when working on the sample gas lines and the associated assemblies.

- ▶ Take appropriate protective measures for work (e.g., by wearing a safety mask, protective gloves and acid resistant clothes)
 - ▶ In case of contact with the eyes, rinse immediately with clear water and consult a doctor.
-



NOTICE

Risk of contamination of analyzer

The gas sampling unit and analyzer are flushed with instrument air when the system is not in measuring operation. When the instrument air is switched off, there is the risk of contamination of the analyzer.

- Pull the gas sampling unit out of the exhaust duct when instrument air is not available for a longer period of time.
-

Surfaces



CAUTION DANGER OF BURNS DUE TO HOT SURFACES

Surface can become hot through operation of the device.

- ▶ Wear suitable protective clothes, for example, heat-resistant gloves.
 - ▶ Switch off the device and allow the components to cool down.
-

Span gases



CAUTION

Before working on span gas cylinders or span gas lines: Relieve the span gas pressure.

- ▶ Shut off the span gas cylinder.
 - ▶ Open the span gas valve: Menu: 2 Adjustment → 3 Span gas feed.
 - ▶ Wait for about 1 minute until the pressure in the lines has been relieved.
 - ▶ Close the span gas valve: Menu: 2 Adjustment → 3 Span gas feed.
-

Please note:

- After working on the gas path: Perform a leak tightness check.
 - After exchanging a span gas cylinder: Check the compliance with the span gas concentration set in the menu: 2 Adjustment → 5 Settings → 1 Concentrations
-

11.2 Error messages and possible causes

Overview

Current pending messages are shown on the device display.

Display of current device state data: Logbook.

The following Table only includes those messages with classification "X" that are important for information.

Messages not included in the following Table have no further significance for operation.

Important information

Messages with status “F” must be cleared first.

Close the logbook and open it again to check whether the error is cleared.

Trigger: System

C = Classification

F = Failure

M = Maintenance request

Table 6: Error codes - System

Code	Error text	K	Description	Possible clearance
S001	Temperature too high	F	Measuring cell temperature too high	When $T \geq 360.7$ °C: Check plug-in connectors. When ok: Call E+H Service.
				When $T < 360.7$ °C: Call E+H Service.
			Optic head temperature too high	When $T \geq 151.2$ °C: Check plug-in connectors. When ok: Call E+H Service.
				When $T < 151.2$ °C: When cabinet temperature ≥ 55 °C: Check cabinet fan / replace filter pad. Otherwise, call E+H Service.
			Temperature of heating for an assembly too high	Check device documentation to clarify which assembly is affected.
				When $T \geq 360.7$ °C: Check plug-in connectors. When ok: Call E+H Service.
				When $T < 360.7$ °C: Call E+H Service.
			LPMS01 (1/2 control) temperature too high	When enclosure temperature ≥ 55 °C: Check cabinet fan / replace filter pad.
				When enclosure temperature < 55 °C: Check fan of electronics unit / clean or replace filter pad. Otherwise, call E+H Service.
			LPMS02 (power electronics) temperature too high	When enclosure temperature ≥ 55 °C: Check cabinet fan / replace filter pad.
				When enclosure temperature < 55 °C: Call E+H Service.
			LPMS03 temperature too high	When no error message for optic head temperature: Call E+H Service. Otherwise, see optic head error clearance

Code	Error text	K	Description	Possible clearance
S002	Temperature too low	F		<p>Check system documentation to clarify which assembly is affected (heating circuit 1 ..7).</p> <p>Check circuit breaker</p> <ul style="list-style-type: none"> • Circuit breaker has triggered: Check all affected lines for damage. Check the plugs. When ok: Perform reset of circuit breaker. Check all plugs are plugged correctly. • Circuit breaker has not triggered: When heating hose affected: Connect new PT100. Otherwise, call E+H Service.
S004	Flow too low	F		When pressure error, clear it first. Sample gas flow too low and purge/zero gas flow ok: Check/replace sampling filter
				Sample gas flow and purge/zero gas flow too low: Call E+H Service.
				Purge/zero gas flow too low and sample gas flow ok: Check all hose connections. When ok: To be checked by E+H Service.
S005	Cell pressure too high	F		Only sample gas pressure too high: <ul style="list-style-type: none"> • Ensure sample gas pressure within device specification. • When not possible: Call E+H Service.
				Purge/zero gas and sample gas pressure too high: <ul style="list-style-type: none"> • Exhaust gas hose crimped/blocked? • Counter-pressure in exhaust duct too high? • Check all hose connections. When ok: Call E+H Service.
				Only purge/zero gas pressure too high: <ul style="list-style-type: none"> • Set correct pressure on pressure reducer unit. When ok: Call E+H Service.
S006	Cell pressure too low	F		Call E+H Service.
S008	Chopper	F	Chopper frequency not regulated.	Call E+H Service.
S009	Motor filterwheel 1	F	Filterwheel motor does not detect reference position.	Call E+H Service.
S010	Motor filterwheel 2			
S011	Motor filterwheel 3			
S012	IR source	F	Voltage or current outside tolerance	Call E+H Service.
S013	5 Volt power	F	Outside tolerance	Call E+H Service.
S014	24 Volt power	F	Outside tolerance	Call E+H Service.
S015	Detector signal	F		Call E+H Service.
S016	Ref.energy too low	F		Call E+H Service.

Code	Error text	K	Description	Possible clearance
S018	O ₂ sensor failure	F		Check plug connection. When ok: Call E+H Service.
S019	O ₂ adj. factor too high	F		Perform O ₂ adjustment again. When message is still pending: Call E+H Service.
S024	No active component	F	When "active" checkmarks of all components are inactive	When current backup available: Load backup. Otherwise: Call E+H Service.
S025	Evaluation module failure	F	Evaluation module can not be started.	When current backup available: Load backup. Otherwise: Call E+H Service.
S026	Evaluation mod. file error	F	Files for evaluation module not created	When current backup available: Load backup. Otherwise: Call E+H Service.
S027	No result	F		When current backup available: Load backup. Otherwise: Call E+H Service.
Maintenance				
S033	Dev. zero point too high	M	Parameters set for measured component	Check zero gas for pressure and cleanliness. Perform maintenance on compressed air conditioning unit. Perform manual zero point adjustment twice (menu: 2 Adjustment → 1 Adjustment → 1 Zero point adjustment). When message occurs again during next automatic zero point adjustment: Call E+H Service.
S034	Config. I/O mod.	M	Configuration error, found module does not correspond to that of the nominal configuration	Check IO modules, check plug connectors and voltage supply, load backup if necessary. Otherwise: Call E+H Service.
S035	Ref.energy too low	M		Call E+H Service.
S036	O ₂ sensor failure	M		Call E+H Service.
S038	Current invalid	M	Analog output: Desired current not reached.	Check connections on the Analog module.
S039	Current invalid	M	Analog input: Current outside valid range.	
S040	Flow too high	M		Call E+H Service.
S041	Flow too low	M		When pressure error, clear it first. Sample gas flow too low and purge/zero gas flow ok: Check/replace sampling filter
				Sample gas flow and purge/zero gas flow too low: Call E+H Service.
				Purge/zero gas flow too low and sample gas flow ok: Check all hose connections. Check zero gas needle valve setting. When ok: To be checked by E+H Service.
S043	IR source weak	M	Voltage or current outside tolerance	Call E+H Service.

Code	Error text	K	Description	Possible clearance
S045	Dev. span adjust too high	M	Gas adjustment not performed because it is outside the tolerable range; parameters set for measured component	Check that correct span gas is connected, span gas concentration is entered correctly and the certificate is still valid. Perform new span gas adjustment, when message is still pending: Call E+H Service.
S046	Dev. int. adjust too high	M	Adjustment with internal adjustment filters not performed because it is outside the tolerable range; parameters set for measured component	Check instrument air and zero gas quality. Perform adjustment again with internal adjustment filters. When message is still pending: Call E+H Service.
S047	Dev. O ₂ adjust too high	M	O ₂ adjustment not performed because it is outside the tolerable range; parameters set for measured component	Perform O ₂ adjustment again, when message is still pending: Call E+H Service.
S048	Alarm O ₂ measured value	M	The current O ₂ measured value is outside the alarm limits.	
S049	SD card not detected	M		Check the SD-card seat. When ok: Call E+H Service.
S050	Adjust factor is zero	M		Check entry of span gas concentration.
S055	O ₂ adjust factor too high	M	O ₂ adjustment factor is above warning limit.	Call E+H Service.
Error				
S113	Check sum error	F	Error in communication between CAN node and I/O module	Check I/O modules, cable damage.
S114	Communication error	F	Interruption in communication between CAN node and I/O module	
S116	Connection was interr.	F	Signals that the output was switched free from current because of the time-out.	Check I/O modules, cable damage.

11.3 Replacing the Electronics module filter pad

Overview

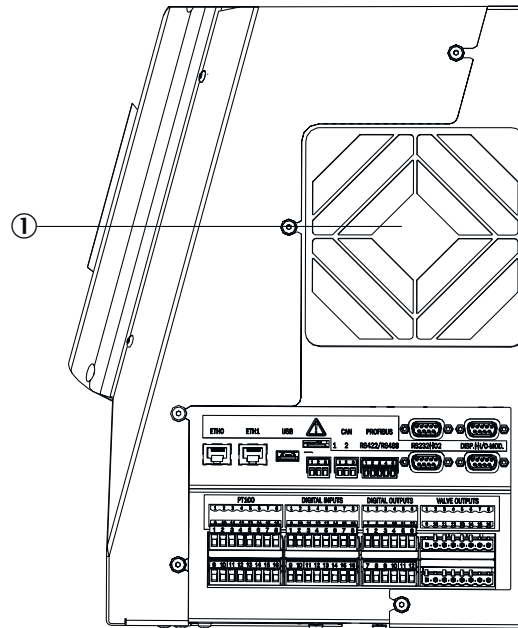

Figure 20: Electronic housing (right side)

Important information



NOTICE

Dirt can get into the device when replacing the filter pad.

- ▶ Only replace the filter pad when the device is switched off.

Prerequisites

- The device is switched off.

Procedure

1. Pull cover ① off.
2. Replace the filter pad inside.

12 Decommissioning

12.1 Switching off

12.1.1 Switching off

Important information



NOTICE

Risk of contamination of analyzer

The gas sampling unit and analyzer are flushed with instrument air when the system is not in measuring operation. When the instrument air is switched off, there is the risk of contamination of the analyzer.

- Pull the gas sampling unit out of the exhaust duct when instrument air is not available for a longer period of time.
-

Procedure

1. Switch system off at the external power disconnection unit.
2. Purge system with instrument air for a minimum of 10 minutes.
3. Switch the calibration gases off.
4. Ensure no sample gas reaches the analyzer.

12.1.2 Shutdown

Prerequisites

- System is switched off.

Procedure

1. Ensure the gas sampling unit can not be contaminated (e.g. by pulling the probe tube)
2. Switch external instrument air off.
3. Close off gas inlets and outlets gas-tight

Related topics

- Switch system off: [see "Switching off"](#)

12.2 Return delivery

12.2.1 Shipping for repair

Overview

You can find all information on the repair flat rates, Repair Form (incl. Non-Risk Declaration and return information) at www.endress.com.

Important information



NOTE

Without the Non-Risk Declaration, the device will either be cleaned by a third-party company at the customer's expense or the package will not be accepted.

Procedure

1. Contact your local Endress+Hauser representative. Addresses: See last page of Operating Instructions.

2. Clean device.
3. Fill in the Repair Form including the Non-Risk Declaration and send it in advance to the Endress+Hauser representative by e-mail.
4. Pack the unit carefully and shockproof in the original packaging for transport.
5. Enclose the Repair Form and attach it to the outside of the packaging.

12.2.2 Cleaning the device before returning

Important information



NOTICE

Device damage through incorrect cleaning.

- Close the housing before cleaning so that no fluid can penetrate.
 - Do not use a high-pressure cleaner, aggressive mechanical or chemical cleaning agents.
-

Prerequisites

- Device is voltage-free.

Procedure

Clean surfaces and parts with media contact

1. Remove loose contamination with compressed air.
2. Remove adhering contamination with a mild soap solution and a soft cloth.
3. Do **not** clean optical surfaces.

12.3 Transport

Procedure

1. Protect the device before transport.
2. Use the original packaging for transport or alternatively a suitable padded stable packaging.
A transport container with adequate stability can also be used.
3. Protect the device with padding from shocks and vibrations.
4. Thoroughly secure the device in place inside the transport container. Make sure there is sufficient space between the analyzer and the walls of the transport container.

12.4 Disposal

Important information



NOTE

The following subassemblies contain substances that may have to be disposed of separately:

- Electronics: Capacitors, rechargeable batteries, batteries.
 - Display: Liquid of LC display.
 - All parts with media contact can be contaminated with harmful substances.
-

Disposal of the device

The device can easily be disassembled into its components which can then be sent to the respective raw material recycling facilities.

- Dispose of electronic components as electronic waste.
- Check which materials having contact with the pipeline must be disposed of as hazardous waste.
- Batteries must not be disposed of with household waste. The battery and the device must be disposed of separately in accordance with local waste disposal regulations.

13 Technical data

13.1 Dimensional drawings

Important information



NOTICE

Observe clearances at the installation site:

- Top: 30 cm
- Side 20 cm

Dimension drawing MCS200HW

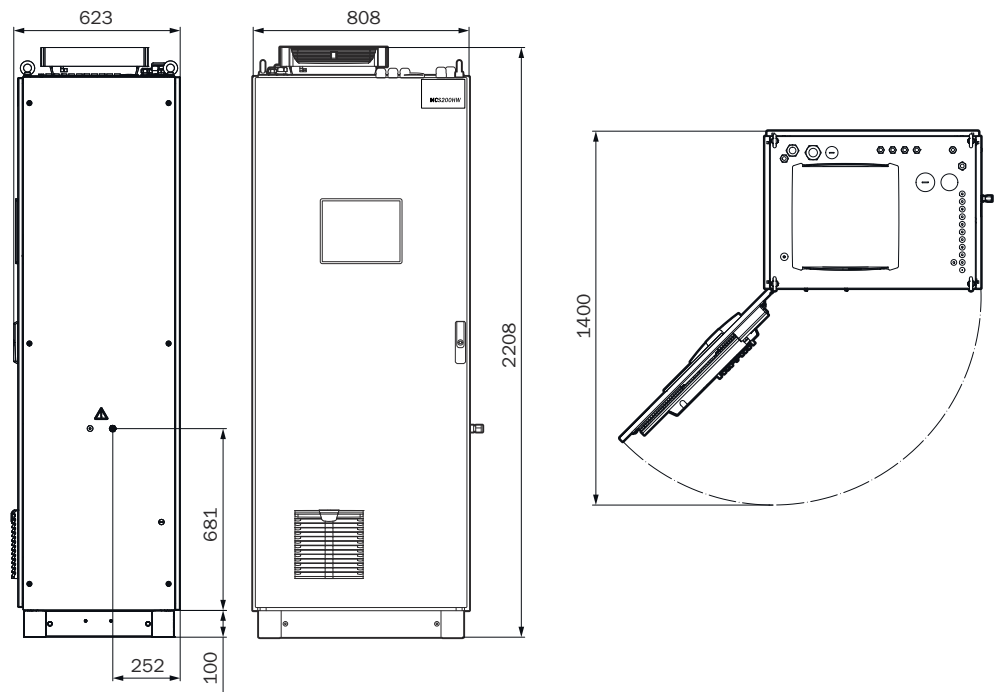

Figure 21: Dimension drawing MCS200HW in basic configuration

All dimensions in the dimension drawing are in mm.

Dimension drawing MCS200HW with cooling unit

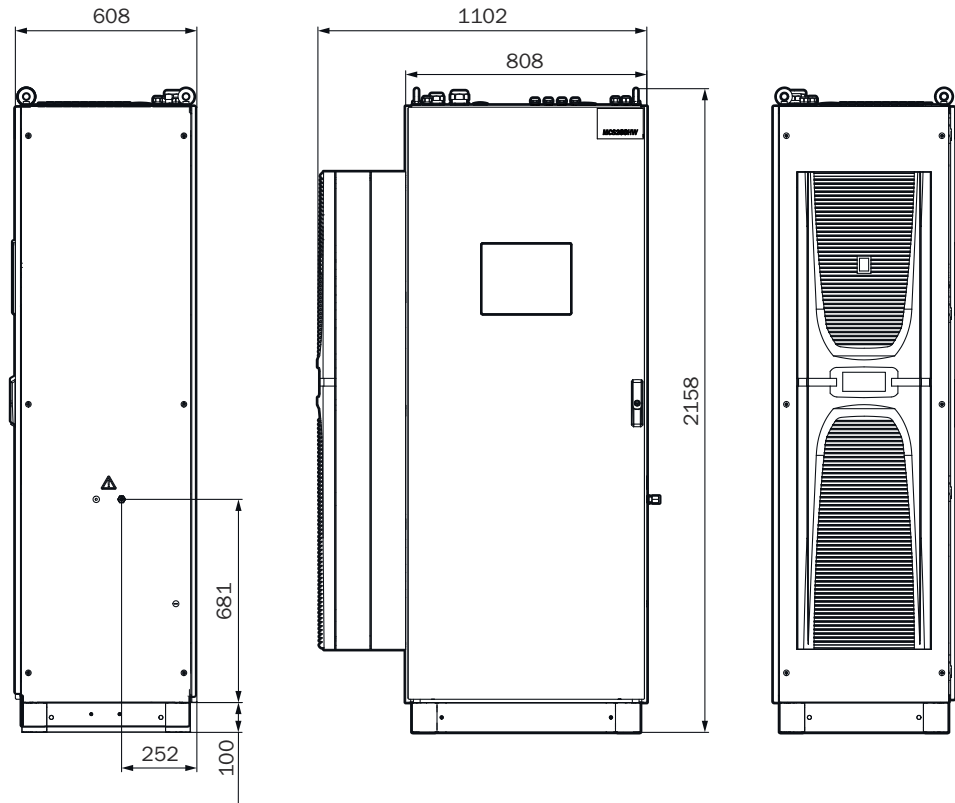

Figure 22: Dimension drawing MCS200HW with cooling unit

All dimensions in the dimension drawing are in mm.

Dimension drawing MCS200HW in stainless steel

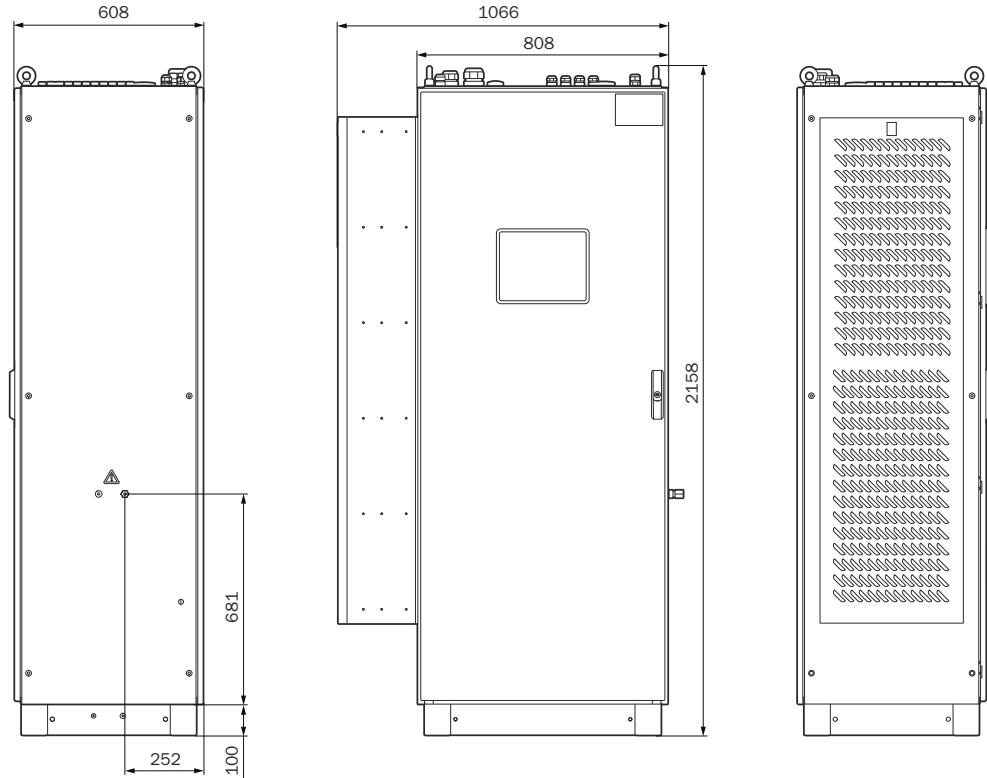

Figure 23: Dimension drawing MCS200HW in stainless steel

All dimensions in the dimension drawing are in mm.

13.2 Technical data

13.2.1 Measured values

Table 7: Measured variables

Number of measured variables	
Number of measured variables	10 IR components + O ₂ + TOC (optional)

Table 8: Measuring method

Measuring method	
Measuring method	Hot extractive

Table 9: Sample volume

Sample volume	
Sample volume	200 ... 400 l/h

Table 10: Measuring ranges

Component	Measuring range
HCl	0 ... 9 ppm; 0 ... 1840 ppm
NH ₃	0 ... 15 ppm; 0 ... 650 ppm
CO	0 ... 60 ppm; 0 ... 8.000 ppm

Component	Measuring range
NO	0 ... 110 ppm; 0 ... 1.865 ppm
CH ₄	0 ... 70 ppm; 0 ... 700 ppm
NO ₂	0 ... 25 ppm; 0 ... 240 ppm
CO ₂	0 ... 25% by volume; 0 ... 50% by volume
SO ₂	0 ... 26 ppm; 0 ... 875 ppm
H ₂ O	0 ... 40% by volume
O ₂	0 ... 25% by volume
N ₂ O	0 ... 50 ppm; 0 ... 1.015 ppm
TOC	0 ... 15 mg/m ³ ; 0 ... 10,000 mg/m ³

Table 11: Certified measuring ranges in accordance with EN15267-3

Component	Certified measuring ranges	Additional measuring ranges
HCl	0 ... 15 mg/m ³	0 ... 3,000 mg/m ³
NH ₃	0 ... 10 mg/m ³	0 ... 500 mg/m ³
CO	0 ... 75 mg/m ³	0 ... 10,000 mg/m ³
NO	0 ... 150 mg/m ³	0 ... 2,500 mg/m ³
CH ₄	0 ... 50 mg/m ³	0 ... 500 mg/m ³
NO ₂	0 ... 50 mg/m ³	0 ... 500 mg/m ³
SO ₂	0 ... 75 mg/m ³	0 ... 2,500 mg/m ³
N ₂ O	0 ... 100 mg/m ³	0 ... 2,000 mg/m ³
CO ₂	0 ... 25% by volume	—
H ₂ O	0 ... 40% by volume	—
O ₂	0 ... 25% by volume	—
TOC	0 ... 15 mg/m ³	0 ... 50/150/500 mg/m ³

Table 12: Measured value characteristics

Measured value characteristics	
Measuring principle	Photometric
Measuring precision	< 2% of the respective full scale value
Detection limit	< 2% of the respective full scale value
Sensitivity drift	< 2% of the respective full scale value per week
Zero point drift	< 2% of the respective full scale value per week
Span drift	< 2% of the respective full scale value per week
Setting time t ₉₀	< 200 s, total measuring path as from probe extraction

13.2.2 Ambient conditions

Table 13: Operation

Ambient conditions in operation	
Installation location	Indoor installation
Ambient temperature	+5 ... +40 °C
Ambient temperature with cooling unit option	+5 ... +50 °C
Relative humidity	< 90% (without condensate)
Air pressure	850 ... 1100 hPa

Table 14: Storage

Ambient conditions in storage	
Ambient temperature	-20 ... +70 °C
Relative humidity	< 90% (without condensate)

13.2.3 Housing

Table 15: Design

Design	
Design	1 x stand-alone enclosure
Material, general	Steel plate, aluminium cast Stainless steel, cast aluminum
Dimensions	see "Dimensional drawings", page 67
Installation	Upright
Weight	Approx. 200 kg
Materials with media contact	<ul style="list-style-type: none"> Stainless steel 1.4571 PTFE Aluminium (coated)
Enclosure rating	IP 54
Impact resistance	IK08

13.2.4 Interfaces and protocols

Table 16: Interfaces and protocols

Operation and interfaces	
Operation	Via display or Google Chrome browser with SOPASair software, several operating levels, password-protected
Display and input	Foiled color display with touchscreen
Analog inputs/outputs	Optional
Digital inputs/outputs	Optional
Data interface	1 x Modbus TCP/IP
Profibus	Configurable
Profinet	Configurable
Remote support	Endress+Hauser MPR (optional) SSG (optional)
PC operation	Browser Google Chrome with SOPASair via Ethernet

13.2.5 Power supply

Table 17: Voltage supply

Voltage supply	
Power input	Power input
<ul style="list-style-type: none"> Analyzer Heated sample gas line Gas sampling unit Heated probe tube 	<ul style="list-style-type: none"> Approx. 1000 VA Approx. 95 VA/m Approx. 450 VA Approx. 450 VA

Table 18: Optional interfaces

Interfaces (optional)	
Digital outputs	4 outputs, 24 V, 0.5 A

Interfaces (optional)	
Digital inputs	Electrically isolated, 24 V, 0.3 A

Table 19: Cable glands

Cable glands	
Hose bundle line	M40x1.5 D22 -32 IP68 PA-GR
Main power supply	M32x1.5 D18 -25 IP68 PA-GR
UPS power supply	M20x1.5 D10 -14 IP68 PA-GR
External I/O lines (digital/analog)	M20x1.5 D10 -14 IP68 EMC
Ethernet interface	M20x1.5 D6 -12 IP68 EMC-D

13.2.6 Gas supply

Important information



NOTICE

Malfunction of the measuring device due to unsuitable instrument air
 Operation with air not satisfying the specifications voids the warranty and does not ensure proper functioning of the measuring device.

- ▶ Only feed conditioned instrument air to the measuring device.
- ▶ The instrument air quality must meet the specification.

Supply gases

Table 20: Supply gases

Gas	Quality	Inlet pressure	Flow rate
Instrument air (zero gas quality)	Particle size max. 5 µm Pressure dew point max. -40 °C Oil content max. 0.01 mg/m ³ ISO 8573-1:2010 [1:2:2]	600 ... 700 kPa (6.0 ... 7.0 bar)	Approx. 350 l/h Approx.. 1300 l/h (with backflush)
Inlet of instrument air solely as induction air for ejector	Particle size max. 5 µm Pressure dew point max. +3 °C Oil content max. 0.1 mg/m ³ ISO 8573-1:2010 [1:4:3]	500 ... 700 kPa (5.0 ... 7.0 bar)	Approx. 1300 l/h
Air dryer (option)	With the air dryer option, approx. 3,000 l/h additional instrument air are required		
External span gas	Span gas must comply with the specifications of the standards to be applied	Max. 400 kPa (3.5 bar)	Approx. 350 l/h

13.2.7 Tube connections

Table 21: Tube connections

Connection	Dimension
Sample gas inlet	Clamping ring screw connection (hose fitting) 4 mm inner diameter 6 mm outer diameter
Induction air ejector	DN 6/8
Span gas inlet	Clamping ring screw connection (hose fitting) 4 mm inner diameter 6 mm outer diameter

Connection	Dimension
Gas outlet	DN 8/10

13.2.8 Sample gas conditions

Table 22: Sample gas characteristics

Sample gas at sampling point	Characteristic
Process temperature	10 ... 550 °C
Sample gas temperature assembly: <ul style="list-style-type: none"> • Sample gas probe • Sample gas line • Cell 	Temperature: <ul style="list-style-type: none"> • Approx. 200 °C • Approx. 200 °C • Approx. 200 °C
Process pressure	-200 ... +200 hPa relative
Dust load	< 200 mg/m ³

13.2.9 Connections in analyzer

13.2.9.1 Voltage supply - connection / fuses

Overview

The voltage supply is located on the left on the analyzer.

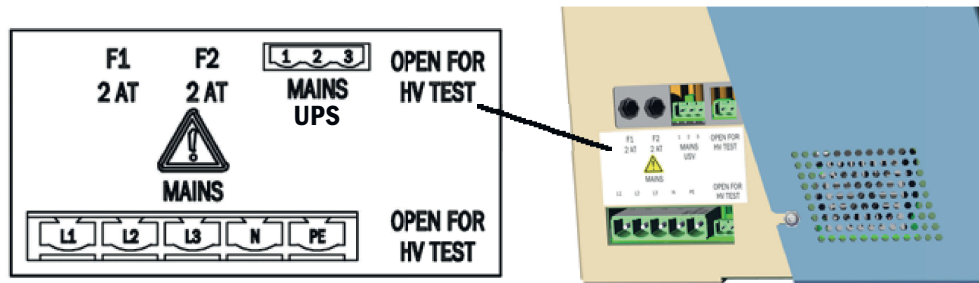

Voltage supply - connections

Table 23: Voltage supply - connections

Name	Supply
MAINS UPS (3-pole)	Voltage supply for electronics unit (internal)
MAINS (5-pole)	External voltage supply
F1	Internal
F2	Internal

Table 24: Connection terminal - power voltage connection on the analyzer

Wire	Cross-section in mm ²	Cross-section in AWG	Tightening torque Nm
rigid	0.75 ... 10.0	18 ... 8	1.2 ... 1.5
flexible with ferrules	0.5 ... 6.0	18 ... 8	
flexible with ferrules with insulating collar	0.5 ... 6.0	18 ... 8	

13.2.9.2 Electronics fuses

Overview

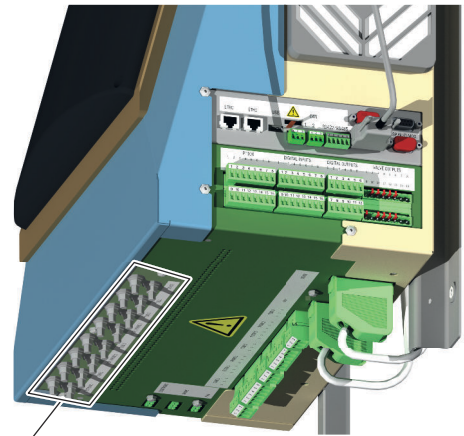

ELECTRONIC TUBE 1 FILTER TUBE 2 FILTER TUBE 3 CELL DEVICE
 PROBE 1 PROBE 2

Fuse connections

Name	Fuse for
ELECTRONIC	Electronics
TUBE 1	Sample gas line 1
FILTER/PROBE 1	Filter heater / measuring probe 1
TUBE 2	Sample gas line 2
FILTER/PROBE 2	Filter heater / measuring probe 2
TUBE 3	Sample gas line 3
CELL	Sample gas cell
DEVICE	Device

13.2.9.3 Connections for heated components

Overview

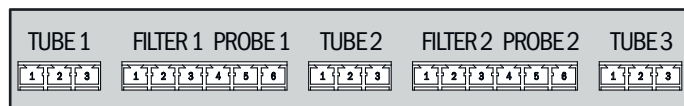
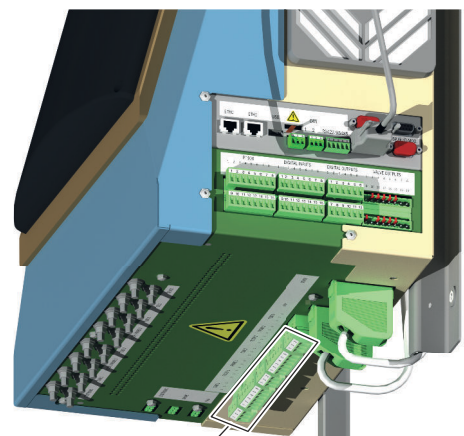

Connections - pin assignment

Table 25: Connections - pin assignment

Plug	Assembly	Pin	Assignment
TUBE 1	Sample gas line 1	1	L (L)
		2	N (L)
		3	PE
FILTER1	Gas sampling unit filter 1 (Lines from hose bundle line)	1	L (L)
		2	N (L)
		3	PE
PROBE1	Gas sampling unit gas sampling probe 1 (Lines from hose bundle line)	4	L (L)
		5	N (L)
		6	PE (not connected)
TUBE2	Sample gas line 2	1 ... 3	As for TUBE1
FILTER2	Gas sampling unit filter 2	1 ... 3	As for FILTER1
PROBE2	Gas sampling unit gas sampling probe 2	4 ... 6	As for PROBE1
TUBE3	Sample gas line 3	1 ... 3	As for TUBE1

¹ The connections must match the connections on the gas sampling unit.

Table 26: Connection terminal - external heater outputs on the analyzer

Wire	Cross-section in mm ²	Cross-section in AWG	Tightening torque Nm
rigid	0.2 ... 4.0	24 ... 10	0.5 ... 0.6
flexible with ferrules	0.25 ... 4.0	24 ... 10	
flexible with ferrules with insulating collar	0.25 ... 4.0	24 ... 10	

13.2.9.4 Connections for interfaces and SD card

Overview

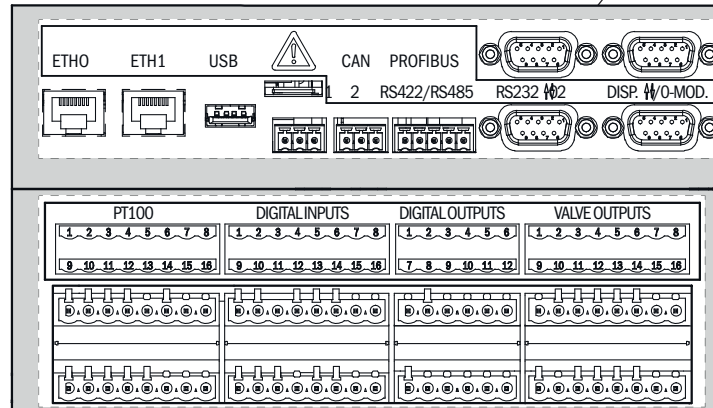
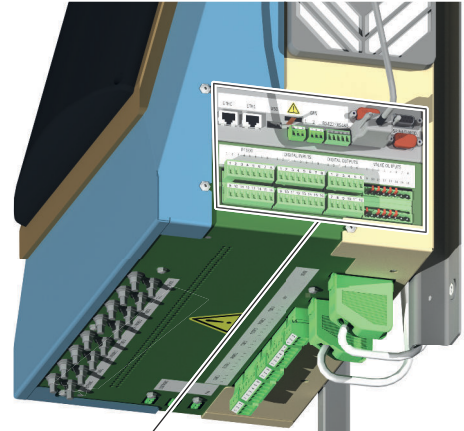

Data interfaces - overview

Table 27: Data interfaces - overview

Plug	Connection for
ETH0	Ethernet (e.g. SOPAS ET), MPR (remote maintenance), communication via Modbus TCP - line is led upwards
ETH1	Internal
USB	Internal
SD card	SD card (on the right, next to USB)
CAN1	Internal
CAN2	Internal
RS422, RS485	Internal
RS232 (top plug)	Internal
O2 (bottom plug)	O ₂ sensor
DISP (top plug)	Display
I/O-MOD (bottom plug)	Internal

Table 28: Connection terminal - CAN interface, RS485 interface

Wire	Cross-section in mm ²	Cross-section in AWG	Tightening torque Nm
rigid	0.14 ... 1.5	28 ... 16	0.22 ... 0.25
flexible with ferrules	0.25 ... 1.5	26 ... 16	
flexible with ferrules with insulating collar	0.25 ... 0.75	26 ... 19	

Table 29: Overview - pin assignment and signals

Plug	Assembly	Pin	Assignment
Pt100	Sample gas line 1	1	Pt100 +
		2	Pt100 -
	Gas sampling unit filter 1	3	Pt100 +
		4	Pt100 -
	Gas sampling unit probe tube 1	5	Pt100 +
		6	Pt100 -
	Not connected	7	
		8	
	Sample gas line 2	9, 10	As above
	Gas sampling unit filter 2	11, 12	As above
Gas sampling unit probe tube 2	13, 14	As above	
Sample gas line 3	15	Pt100 +	
	16	Pt100 -	
DIGITAL INPUTS	Digital input 1	1	+ 24 V
		2	+ Signal
		3	- Signal
		4	GND
	Digital input 2	5 ... 8	As above
	Digital input 3	9 ... 12	As above
Digital input 4	13 ... 16	As above	
DIGITAL OUTPUTS	Digital output 1	1	NC
		2	COM
		3	NO
	Digital output 2	4 ... 6	As above
	Digital output 3	7 ... 9	As above
Digital output 4	10 ... 12	As above	
VALVE OUTPUTS	Valves		Internal

¹ The connections must match the connections on the gas sampling unit.

Table 30: Connection terminal - PT100 signal inputs, DI, DO on analyzer

Wire	Cross-section in mm ²	Cross-section in AWG	Tightening torque Nm
rigid	0.2 ... 2.5	24 ... 12	0.5 ... 0.6
flexible with ferrules	0.25 ... 2.5	26 ... 12	
flexible with ferrules with insulating collar	0.25 ... 2.5	26 ... 12	

13.2.10 Heated sample gas line

Table 31: Sample gas line - characteristics

Sample gas line	
Length	Max. 50 m certified, longer sample gas lines on request
Ambient temperature	-20 ... +80 °C
Working temperature	Max. 200 °C
Temperature control	1 x Pt100
Voltage supply	115 V or 230 V
Power consumption	90 VA/m
Enclosure rating	IP 54

13.2.11 Switching on the circuit breakers again

Overview

The circuit breakers are located at the bottom of the electronics unit.

The circuit breakers are labeled.

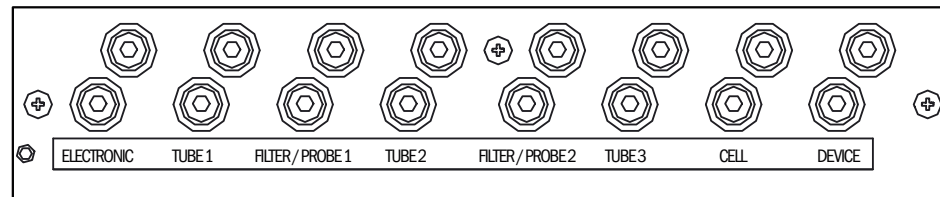

Procedure

When a circuit breaker has triggered

1. Press the circuit breaker pin back in again.
2. If this does not switch the circuit breaker on again, wait a few minutes (cooling down phase) and press the pin back in again.
3. If this does not switch the circuit breaker on again, check the assembly and replace when necessary.

13.2.12 Torques for screw fittings

Overview

Tighten all screw connections, for which no tightening torque or no pretension force is specified in drawings or Assembly Instructions, according to VDI 2230.

Exceptions to this rule are all connections with screws that are not screw connections in the real sense. This includes hose clips, cable glands, screw fittings, gas connections, screws for circuit boards etc. Tighten these screw fittings as evenly as possible with a much lower torque (hose clips 1 Nm, other screw fittings according to manufacturer specifications).

Select the next lowest torque valid for the screw for mixed materials and special screws such as relieved screws.

The basic friction coefficient is (screw fittings without lubrication) $\mu_k = \mu_G = 0.14$. The calculated values are valid for room temperature ($T = 20^\circ\text{C}$).

Torques

Table 32: Torques

Dimension	Slope P	Tightening torque M _A (Nm) according to strength class (see screw head)							
		3.6	4.6 A2-50 A4-50	5.6 Alu	A2-70 A4-70	A2-80 A4-80	8.8 Titan	10.9	12.9
M 1.6	0.4	0.05	0.05	0.05	0.11	0.16	0.19	0.26	0.31
M 2	0.45	0.1	0.1	0.11	0.22	0.32	0.39	0.55	0.66
M 2.5	0.45	0.21	0.22	0.23	0.46	0.67	0.81	1.13	1.36
M 3	0.5		0.54	1	1.2	1.39	1.51	1.98	2.37
M 3.5	0.6		0.85	1.3	1.54	1.75	1.9	2.6	3.2
M 4	0.7		1.02	2	2.5	3	3.3	4.8	5.6
M 5	0.8		2	2.7	4.2	5.6	6.5	9.5	11.2
M 6	1		3.5	4.6	7.3	9.7	11.3	16.5	19.3
M 8	1.25		8.4	11	17.5	23.3	27.3	40.1	46.9
M 10	1.5		17	22	35	47	54	79	93
M 12	1.75		29	39	60	79	93	137	160
M 14	2		46	62	94	126	148	218	255
M 16	2		71	95	144	192	230	338	395
M 18	2.5		97	130	199	266	329	469	549
M 20	2.5		138	184	281	374	464	661	773
M 22	2.5		186	250	376	508	634	904	1057
M 24	3		235	315	485	645	798	1136	1329
M 27	3		350	470	708	947	1176	1674	1959
M 30	3.5		475	635	969	1289	1597	2274	2662
M 33	3.5		645	865	1319	1746	2161	3078	3601
M 36	4		1080	1440	1908	2350	2778	3957	4631
M 39	4		1330	1780	2416	3016	3597	5123	5994

14 Annex

14.1 Conformities

Conformities

- EC Directive: LVD (Low Voltage Directive)
EN 61010-1: Safety requirements for electrical equipment for measurement, control and laboratory use
- EC Directive: EMC (Electromagnetic Compatibility)
EN 61326: Electrical equipment for measurement, control and laboratory use, EMC requirements

Further standards and directives: See Declaration of Conformity provided with the device.

14.2 Licenses

14.2.1 Liability disclaimer

The firmware for this device has been developed using Open Source Software. Any changes to the Open-Source components are in the general responsibility of the user. All warranty claims are excluded in this case.

The following exclusion of liability applies to the GPL components in relation to the rights holders: This program is distributed in the hope that it will be of use, but with no guarantee of this; neither is there any implied guarantee of marketability or suitability for a particular purpose. Refer to the GNU General Public License for details.

With regard to the other Open-Source components, we refer to the liability disclaimers of the copyright holders in the licence texts on the CD delivered.

14.2.2 Software licences

In this product, Endress+Hauser uses unchanged and, as far is necessary and in compliance with relevant licence conditions, changed Open Source Software.

The firmware of this device is therefore subject to the copyrights listed on the CD delivered. Please refer to the storage medium delivered for a complete list of the Open Source programs used as well as the relevant licence conditions.

14.2.3 Source codes

The source codes for the Open Source programs used in this device can be requested using the following email address: Please enter "Open Source Software" as subject.

8029894/AE00/V3-2/2023-12

www.addresses.endress.com
