

Operating Instructions

Smoldering Fire Detection System

Described Product

Product name: Smoldering Fire Detection System

Manufacturer

Endress+Hauser SICK GmbH+Co. KG
Bergener Ring 27
01458 Ottendorf-Okrilla
Germany

Legal notice

This work is protected by copyright. Endress+Hauser SICK GmbH+Co KG retains the rights conferred by it. Reproduction of this work or parts thereof is only permitted within the limits of the statutory provisions of copyright law.

Any modification, abridgment or translation of the work without the express written consent of Endress+Hauser SICK GmbH+Co KG is prohibited.

The trademarks mentioned in this document are the property of their respective owners.

©Endress+Hauser SICK GmbH+Co KG. All rights reserved.

Original document

This document is an original document of Endress+Hauser SICK GmbH+Co. KG



Content

- 1 About this Document 5**
 - 1.1 Limitation of Liability..... 5
 - 1.2 Purpose of this Document 5
 - 1.3 Target Groups..... 5
 - 1.4 Further Information..... 5
 - 1.5 Additional Technical Documents/Information:..... 6
 - 1.6 Document Conventions..... 6

- 2 Safety Information..... 7**
 - 2.1 Intended Use 7
 - 2.2 General Safety Information 7
 - 2.3 Requirements on the Personnel's Qualification 7
 - 2.4 Sources of Danger 8
 - 2.5 System Warranty 8
 - 2.6 RoHS Directive 8
 - 2.7 Safety Conventions 9
 - 2.8 Warning Symbols on the System Components..... 9
 - 2.9 Mandatory Signs 10
 - 2.10 Safety Information..... 10

- 3 System Description 13**
 - 3.1 Internal Functional Units 13
 - 3.2 External Functional Units..... 13
 - 3.3 Measuring Components..... 13
 - 3.4 Interfaces 14
 - 3.5 Description of the Assemblies..... 14
 - 3.5.1 Exterior View 14
 - 3.5.2 Interior View 15
 - 3.5.3 System Components..... 15
 - 3.6 Gas Flow Plan..... 15

- 4 Installation..... 17**
 - 4.1 Installation of Analysis Cabinet 17
 - 4.1.1 Dimensions 17
 - 4.1.2 Installation Requirements..... 17
 - 4.2 Project Planning and Installation Instructions..... 18
 - 4.3 Gas Lines..... 18
 - 4.4 Electrical Installation 19
 - 4.4.1 Main Power Supply 19
 - 4.5 External Components and Signal Generators..... 19
 - 4.6 Connecting to the Customer Plant 19

- 5 Commissioning 21**
 - 5.1 Switching On..... 21

5.2	Sample Gas Cooler	21
5.3	Cabinet Air Conditioning (option)	22
5.4	Gas Detection Systems (option).....	22
5.5	Heated Gas Sampling Probe	23
5.6	Sampling Point Switching and Gas Paths.....	23
5.7	Restart After a Longer Shutdown.....	24
6	Operation	25
6.1	Operating the System Components	25
6.2	Layout and Functions of System Components.....	25
6.3	System Parameters	25
6.4	Sampling Point Switching.....	25
7	Adjustment	27
7.1	Necessary Adjustment.....	27
7.2	Variants of the adjustment Procedure.....	27
7.3	Carrying Out the Adjustment Procedure	27
7.4	Adjustment (Calibration) of External Components and Signal Transmitters ..	27
8	Decommissioning.....	29
8.1	Stand-By Mode - Maintenance Mode	30
8.2	Decommissioning	30
8.2.1	Safety Measure: Secure Connected Systems	30
8.2.2	Safety Measure: Remove the Sample Gas Completely	30
8.2.3	Measurement of Harmless Gases	31
8.2.4	Switching Off.....	32
8.3	Shutdown	32
8.4	Storage	32
9	Maintenance.....	33
9.1	Maintenance Signal.....	34
9.2	Visual Inspection/Functional Check	34
9.3	Maintenance Tasks	35
9.3.1	Maintenance Recommendations / Intervals	35
9.4	Cleaning Information	36
9.5	Condensate Container.....	37
9.6	Recommended Wear Parts (WP) and Spare Parts (SP)	38
10	Troubleshooting	41
10.1	Fuses	41
10.2	Status Display / Group Malfunctions.....	41
10.3	Implausible Measurement Results	41
10.4	Switch-On Conditions.....	41
10.4.1	Status Parameters of the Switch-On Conditions.....	42

11	Leak Test.....	43
11.1	Preparing the Test.....	43
0.31	Leak Test	44
0.42	Perform Leak Test.....	44
12	Specifications.....	45
12.1	Conformities	45
12.2	Technical data	46
13	Disposal.....	47



1 About this Document

Note

This document on the Smoldering Fire Detection System:

- Contains information necessary during the life cycle of the system.
- Must be made available to all persons working with the system.
- Must be read carefully and it must be ensured that the contents are understood completely before working with the system.

1.1 Limitation of Liability

Note

Applicable standards and regulations, the latest state of technological development, and our many years of knowledge and experience have all been taken into account when assembling the data and information contained in these Operating Instructions.

It is therefore pointed out that the manufacturer accepts no liability, in particular in the following cases:

- Failure to comply with this document.
- Failure to comply with information and regulations.
- Unauthorized fitting and installations of third-party components.
- Unauthorized technical and other changes.
- Use of spare parts, consumables, and accessories not authorized by the manufacturer.
- Unauthorized software modifications, adaptations and/or manipulations.
- Failure to carry out regular maintenance work and its documentation.

With special variants, where optional extras have been ordered, or owing to the latest technical changes, the actual scope of delivery may vary from the features and illustrations shown here.

1.2 Purpose of this Document

This document describes the Smoldering Fire Detection System.

1.3 Target Groups

This document is intended for qualified persons installing, operating and maintaining the Smoldering Fire Detection System.

1.4 Further Information

Special local requirements

Follow all local laws, regulations, technical rules and company policies applicable at the installation location.

Retention of documents

This document as well as other applicable technical documents/information:

- Must be kept available for reference.
- Must be passed on to a new system operator / new qualified personnel.

1.5 Additional Technical Documents/Information:

- Operating Instructions of the analyzers
- Electronic Device Passport for analyzers
- Wiring diagram of the Smoldering Fire Detection System

Instructions delivered with the system documentation

Supplementary optional Operating Instructions

- Sampling probe
- Sample gas line
- Supply unit / temperature control
- Components of sample gas conditioning
 - Sample gas pump
 - Sample gas cooler
 - Test gas valves
 - Sample gas monitoring
 - Water trap
- System control LOGO! logic module / PLC (option)
- Control cabinet air conditioning (option)
- Components supplementing the system (option)
- Power supply / main power supply / protective devices

1.6 Document Conventions

▶ Handling instruction



Reference to another document

All units of measurement in this document are metric units.

Subject to change without notice.

Illustrations may differ from the actual design.

2 Safety Information

2.1 Intended Use

The Smoldering Fire Detection System is a Smoldering Fire Detection System and is used for continuous flue gas and emission monitoring at industrial combustion plants and processes.

The sample gas is extracted at a sampling point and fed through the gas analyzer (extractive measurement).

The Smoldering Fire Detection System is not:

- Approved as safety-related control
- Suitable for monitoring the lower and upper explosion limits (LEL/UEL).

2.2 General Safety Information

- ▶ Read this document carefully and adhere to all safety instructions and information before working on the Smoldering Fire Detection System.
- ▶ Only qualified persons from the respective areas are permitted to work on the Smoldering Fire Detection System.
- ▶ Follow operation procedures.
- ▶ Follow local rules.
- ▶ Follow local regulations regarding working with gas and electric components.
- ▶ Only authorized persons are permitted access to the Smoldering Fire Detection System.

System damage/transport damage

Damage to single system components can cause malfunctions of the complete system.

- ▶ Do not ignore system components damaged during transport.
- ▶ Contact SICK Service in case of damage.

2.3 Requirements on the Personnel's Qualification

Only qualified personnel from the relevant specialist areas may carry out work on the system.

- Qualified persons are those who, based on their training, knowledge and experience as well as their knowledge of relevant regulations and standards, are capable of carrying out the tasks given and recognizing and preventing independently hazards involved.
- Electricians have the specialized training, skills and experience as well as knowledge of the relevant standards and regulations to be capable of carrying out work on electrical systems and independently recognizing and preventing hazards involved.

2.4 Sources of Danger

Combustible or ignitable sample gases

No ignitable sample gases may be fed into the analyzer system.

Toxic gases

Toxic gases can lead to poisoning.

Explosive atmospheres

The system may only be installed in a safe zone (not an EX zone).

Risk of explosion in explosive atmospheres.

Electric voltage

Touching live components can lead to death, burning or shock due to electric shock.

Hot surfaces

Risk of injury from hot surfaces.

Suspended loads

Serious injury or death from falling suspended loads.

2.5 System Warranty

Any warranty claim becomes void when:

- ▶ Safety information and measures in this document are disregarded.
- ▶ Parts or components are installed, fitted or changed without authorization on the Smoldering Fire Detection System.
- ▶ The Smoldering Fire Detection System is changed or modified.
- ▶ Software is changed, adapted and/or manipulated without authorization.



2.6 RoHS Directive

This product was designed for specific applications in large-scale industrial plants according to Article 2 (4) e, RoHS 2011/65/EU and accordingly may be used only in such equipment.

The product is neither suited nor authorized for use outside this equipment. SICK can therefore not accept any warranty or liability whatsoever for such use.

2.7 Safety Conventions

The warning information used in these Instructions have the following meaning:







- 
DANGER
 Indicates a dangerous situation which, if not avoided, will result in death or severe personal injury.
- 
WARNING
 Indicates a dangerous situation which, if not not avoided, could result in death or severe personal injury.
- 
CAUTION
 Indicates a dangerous situation which, if not avoided, could result in minor or moderate personal injury.

NOTE

Indicates a harmful situation which, if not avoided, could lead to property damage.

2.8 Warning Symbols on the System Components







Do not remove or cover warning symbols. Replace damaged or missing warning symbols (stickers).

Symbol	Significance
	Warning of danger area
	Warning of dangerous electric voltage
	Warning of hot surfaces
	Warning of suspended loads
	Warning of flammable materials
	Warning of toxic substances

2.9 Mandatory Signs

Mandatory signs indicate a measure required to protect personal health and / or avoid the risk of personal injury.

Do not remove or cover mandatory symbols on the system. Replace damaged or missing mandatory signs (stickers).

Symbol	Significance
	Read document
	Wear protective gloves
	Wear respiratory equipment
	Wear head protection
	Wear foot protection
	Switch off and disconnect from the power supply prior to maintenance or repair

2.10 Safety Information



DANGER
Risk of explosion.

The Smoldering Fire Detection System must not be operated in potentially explosive atmospheres.



DANGER
Risk of explosion with explosive sample gas.

Serious injuries and death.

- ▶ When using explosive gases, do not put the integrated detonation flame arrester out of operation (sample gas line and outlet).



DANGER
Toxic gases

Severe poisoning or death by inhalation.

- ▶ Operate the system in adequately vented areas or rooms.
- ▶ Check permanent fan. When the fan fails, only enter contaminated rooms with PPE (respiratory equipment, gas warning detector).
- ▶ Check hose connections and screw fittings. Perform regular leak tests with leak detection spray and leak tester.
- ▶ Safely discharge the measuring medium at the gas outlets.
- ▶ Observe all local laws, technical rules and operator instructions.

**DANGER****Electric voltage.**

Serious injuries or death.

- ▶ Only qualified personnel may perform electrical work on the system.
- ▶ Disconnect the power supply.
- ▶ Check residual voltages on system components.
- ▶ Increased attention.

**DANGER****Suspended loads.**

Serious injuries or death.

- ▶ Never stand under suspended loads.
- ▶ Special attention when lifting the loads.
- ▶ Comply with the lifting instructions to prevent injuries and accidents.
- ▶ Use suitable lifting equipment.
- ▶ Wear personal protective equipment (safety helmet, safety gloves).

**WARNING****Hot surfaces.**

Serious injury from hot surfaces on probes, filters, and heated sample gas lines.

- ▶ Protect hot surfaces against contact.
- ▶ Wear protective gloves.

**WARNING****Toxic condensate liquid.**

Serious injuries and harmful to the environment.

- ▶ Wear suitable personal protective equipment (PPE).
- ▶ Only open the condensate container in well-ventilated rooms.
- ▶ Safely drain condensate.
- ▶ Disposal in accordance with applicable local environmental regulations and guidelines.

3 System Description

The Smoldering Fire Detection System - Smoldering Fire Detection System is a system for measuring and monitoring gaseous components.

The Smoldering Fire Detection System operates in extractive mode, i.e. the gas to be measured is withdrawn from the gas duct using one or several gas sampling probe(s) and fed to the analysis system via a (heated) sample gas line.

The individual system-specific equipment or the project-specific design of the entire Smoldering Fire Detection System can be found in the wiring diagram, the system overview and the system documents / system documentation supplied.

3.1 Internal Functional Units

- Components for supply / regulation of heated (external) sample gas lines and heated gas sampling probes (option).
- Components for automatic switching between up to four sampling points.
- Sample gas delivery unit comprising:
 - Sample gas pump
 - Control valve / needle valve (option)
 - Flow meter
- Sample gas conditioning comprising:
 - Sample gas cooler with condensate pump, filter,
 - Condensate collection container with level monitor
 - Water trap
 - Sample gas monitoring (flow)
- Reference gas / test gas feeding unit consisting of:
 - Solenoid valves
- Analyzers
- Terminal strips for customer connection

3.2 External Functional Units

- Gas sampling probe, if necessary with integrated back purge (option)
- Sample gas line (option)

Note

External functional units are specific to the project/ and system. Details can be found in the wiring diagram and the project system documentation.

3.3 Measuring Components

Possible measuring components: CO, O₂

System-specific details and information on the measuring components can be found in the analyzer's Electronic Device Passport and the wiring diagram of the Smoldering Fire Detection System.

3.4 Interfaces

- Measured value, status and control display
 - Measured value outputs (analog), freely selectable (0 / 2 / 4 ... 20 mA linear)
 - Status and control outputs
- Measured value and control inputs
 - Measured value inputs (analog) (0 / 2 / 4 ... 20 mA or 0 ... 10 V)
- Digital interfaces (option)
 - RS232
- Voltage supply (system-specific)
 - 400 V, 50 Hz
 - 400 V, 60 Hz
- UPS connection / supply (option)

3.5 Description of the Assemblies

3.5.1 Exterior View

The specific exterior view is shown in the Smoldering Fire Detection System wiring diagram. The following illustration shows the typical structure of the Smoldering Fire Detection System.

This can vary depending on the project and system.

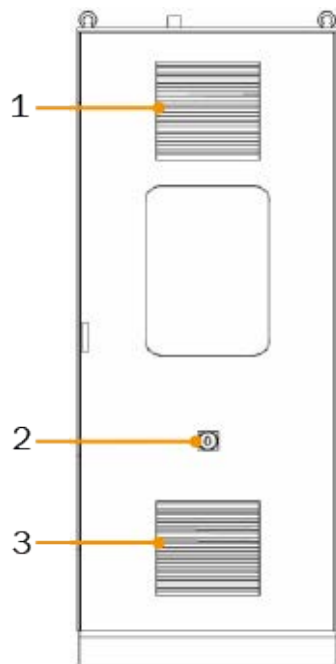

Fig. 1: Exterior view (without air conditioner)

Legend

- | | |
|---|-------------|
| 1 | Air outlet |
| 2 | Main switch |
| 3 | Fan |
-

3.5.2 Interior View

The specific interior view is shown in the wiring diagram of the Smoldering Fire Detection System. This can vary depending on the project and system.

3.5.3 System Components

The specific system components are shown in the wiring diagram of the Smoldering Fire Detection System. These can vary depending on the project and system.

3.6 Gas Flow Plan

The specific gas flow diagram is shown in the wiring diagram of the Smoldering Fire Detection System. The following illustration shows the typical structure of the Smoldering Fire Detection System with sample gas line and reference output at the sample gas probe.

- Design and designations can vary specific to the project and the system. The applicable designations are listed in the project- and system-specific wiring diagram.

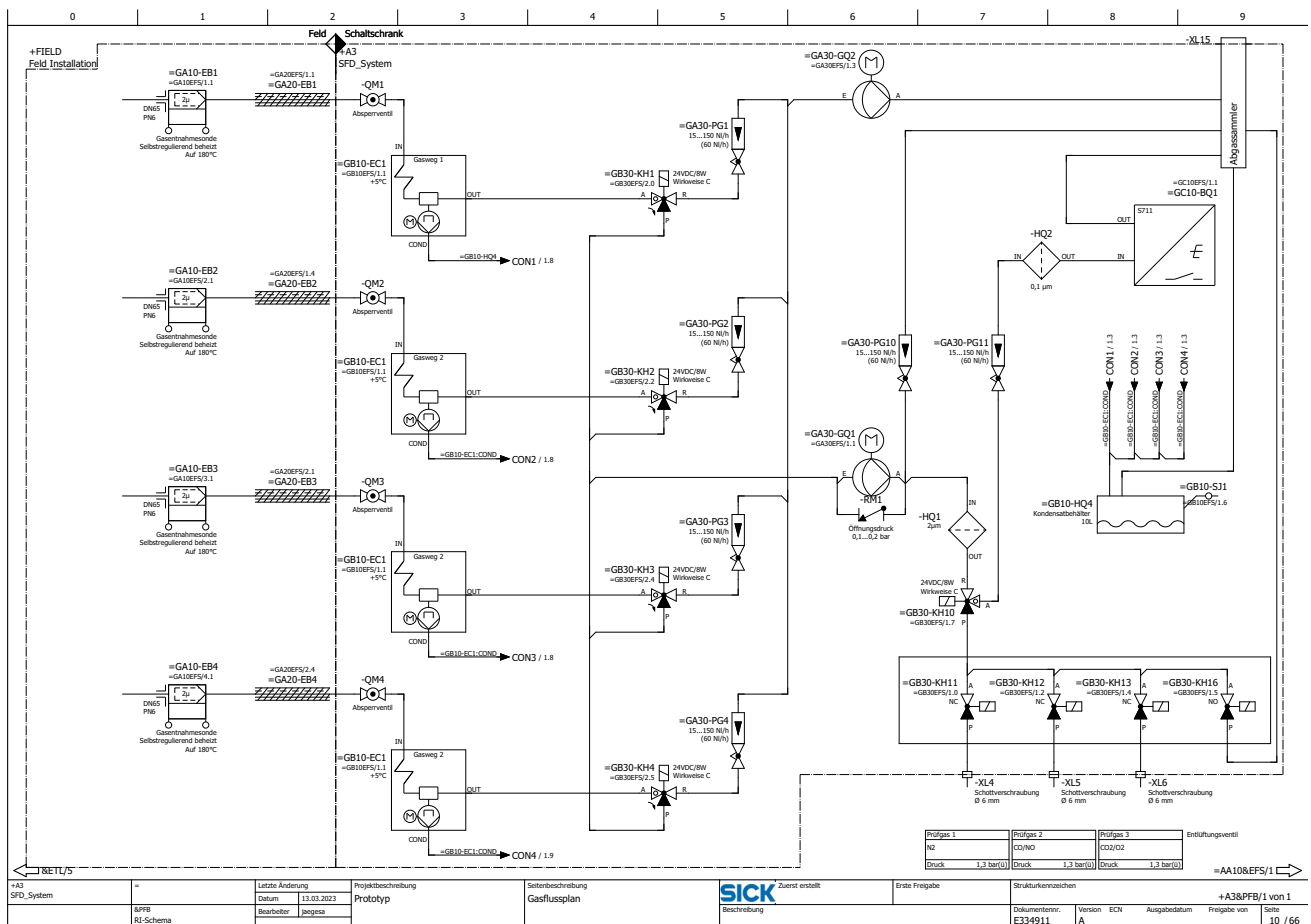

Fig. 2: Gas flow diagram (example)

3 SYSTEM DESCRIPTION

4 Installation

NOTE

Only qualified personnel from the relevant specialist areas may carry out work on the system.



DANGER

Suspended loads.

Serious injuries or death.

- ▶ Never stand under suspended loads.
- ▶ Special attention when lifting the loads.
- ▶ Comply with the lifting instructions to prevent injuries and accidents.
- ▶ Use suitable lifting equipment.
- ▶ Wear personal protective equipment (safety helmet, safety gloves).



DANGER

Electric voltage.

Serious injuries or death.

- ▶ Only qualified personnel may perform electrical work on the system.
- ▶ Disconnect the power supply.
- ▶ Check residual voltages on system components.
- ▶ Increased attention.



Further information on the installation of the Smoldering Fire Detection System can be found in the system documentation, wiring diagram and in the respective Operating Instructions.

4.1 Installation of Analysis Cabinet

4.1.1 Dimensions

Data	Dimensions
Height x width x depth	2100 x 800 x 600 mm
Weight approx.	250 - 350 kg

4.1.2 Installation Requirements

- ▶ Use suitable hoisting gear.
- ▶ The installation site must be free of obstacles and capable of supporting the weight.
- ▶ Do not remove the protective devices of the transport device until the final position has been reached.
- ▶ Connect equipotential bonding (see wiring diagram).



4.2 Project Planning and Installation Instructions

- Set up the cabinet in a low-vibration environment
- Installation as close as possible to the sampling point
- Max. sample gas line 80 m
- When using reference gas cylinders, provide a suitable location
- Provide a suitable location for the instrument air conditioning system
- The air outlet of the control cabinet ventilation / air conditioning must not be blocked
- Check hose connections and screw fittings before installation
- To avoid damage during transport, some components are disassembled and supplied in separate packaging in the control cabinet. These must be mounted or inserted before commissioning
- Observe the Operating/Mounting Instructions for the installation of the gas sampling probe

4.3 Gas Lines

The gas connections for the standard Smoldering Fire Detection System are located on the side or top of the control cabinet

The system-specific design of the analyzer cabinet for the Smoldering Fire Detection System may vary and can be found in the view drawings or the wiring diagram.



DANGER

Explosion hazard with explosive sample gas.

Serious injuries and death.

Installation and commissioning of sample gas lines

May only be performed by trained personnel in accordance with the requirements of EN 60079-14:2014, Annex F, and in accordance with the manufacturer's specifications.

The sample gas lines have a second (spare) inner core that is not connected. It must be sealed with the enclosed blanking plugs to prevent the ingress of explosive dust atmospheres.

4.4 Electrical Installation

The cable ducts on the Smoldering Fire Detection System cabinet are located at the side or on the top of the control cabinet.

The system-specific design of the Smoldering Fire Detection System, may vary and can be found in the view drawings or the wiring diagram.

4.4.1 Main Power Supply

- Lead the main power supply to the analyzer cabinet.
- The wiring system to the power source of the system must be installed and fused in accordance with the relevant regulations.
- Before commissioning, check the main power supply properties for rated current/rated voltage/rated capacity for system supply (auxiliary power) match the system-specific specifications of the Smoldering Fire Detection System.
- ▶ Details on the connection to the power supply and information on the rated current/voltage/power can be found in the system-specific wiring diagram or the system documentation.

4.5 External Components and Signal Generators

Carry out electrical and mechanical connection of project-related external components and signal generators and other project-specific peripherals to be integrated and then put these into operation.

- ▶ Refer to the system-specific wiring diagram and corresponding Data Sheets or Operating Instructions of the respective component for details on the main power supply connection or connection to the Smoldering Fire Detection System as well as specifications on auxiliary power required (rated current/rated voltage/rated capacity)-

4.6 Connecting to the Customer Plant

- ▶ Make all necessary connections according to the system documentation:
 - Power supply
 - Signal cables
 - Integration of all external components
- ▶ Connection of data transfer and evaluation (external interface).

5 Commissioning

NOTE

Only qualified personnel from the relevant specialist areas may carry out work on the system.

Before commissioning:

the system must have been installed for at least 24 hours in its intended operating position at the installation location. This achieves optimum operating conditions and prevents damage to system components.

The ball valves (-QM1 to -QM4) must be closed and the sampling point selector switch must be in position "0".

5.1 Switching On

The applicable designations of the switch-on components can be found in the relevant wiring diagram.

- ▶ Switch on the Smoldering Fire Detection System with the main switch.
- ▶ Switch on the residual-current device (RCD).
- ▶ Switch on all circuit breakers (MCB).
- The Smoldering Fire Detection System system is now in the warming-up phase. Depending on the components to be measured and the measuring ranges, and the drift, the warming-up phase takes up to 24 hours. However, the typical case is that a measurement can take place at an earlier time point, under consideration of a possible drift and compliance with switch-on conditions, for example, reaching the required operating temperature.
- Check external components operated with alternating current, as well as those supplied by the Smoldering Fire Detection System (optional), such as purge air units, fans, compressors, for correct direction of rotation / rotating fields.

5.2 Sample Gas Cooler

For commissioning, observe the Operating Instructions of the sample gas cooler. Wait for the cooler warm-up phase to end (duration: approx. 30 minutes).

A green LED signals that the operating temperature has been reached.

- ▶ Switch on the sample gas cooler at the front of the device.

5.3 Cabinet Air Conditioning (option)

- ▶ Observe the corresponding Operating Instructions and data sheets of the system documentation.
- ▶ Operating parameters and temperature values must be adapted to the local conditions.
- ▶ After installation, a waiting period must be observed before initial start-up.
The duration of the waiting time is shown in the Operating Instructions of the device.

Depending on the place of use, the Smoldering Fire Detection System is equipped with appropriate optional cabinet climate control components.

- Control cabinet fan, cooler, heater

Further information on the commissioning and operation of the individual components can be found in the corresponding Operating Instructions.

The air conditioning components are set to the following operating parameters / temperature values at the factory:

- Control cabinet fan / cabinet thermostat: 25 °C
 - Control cabinet cooling unit: 25 °C
 - Heater: Approx.. 15 °C ... 20 °C
- ▶ These settings must be adapted to local conditions. Internal system components of the Smoldering Fire Detection System analysis system can fail or be damaged when operating / ambient temperatures are too low or high.

Condensate accumulation when the control cabinet door is open

The control cabinet door is usually equipped with a door limit switch.

This delays the switching off or on of the cooling function when the control cabinet door is opened, thus avoiding increased condensate accumulation.

Information on the switching delay can be found in the corresponding Operating Instructions of the cooling unit.

Multiple brief openings of the control cabinet door should be avoided.

5.4 Gas Detection Systems (option)

Depending on the medium to be measured and the type of application, system-specific gas detection systems (gas monitor, gas measuring computer) and the associated visual and acoustic signaling devices are used.

Limit and threshold values (alarm thresholds) have been preset at the factory. These must be adapted by the operator on site, during commissioning, to the local conditions and safety regulations.

- ▶ Corresponding notes and information can be found in the relevant Operating Instructions and Data Sheets of the system documentation.
- ▶ The operator must check on site the limit or threshold values (alarm thresholds) set at the factory and adapt these to local conditions.

Danger due to wrong settings

The settings must comply with the relevant regulations and safety regulations as well as laws on monitoring toxic gases and / or LEL monitoring.

5.5 Heated Gas Sampling Probe



DANGER

Carryover of combustible dusts in non-explosion-proof areas.

Death and serious injuries caused by explosions.

- ▶ Before commissioning the gas sampling probe, check the installed filters and seals for correct seating and damage.
- ▶ Gas sampling probes must not be operated without filters.
- ▶ After each filter replacement or filter cleaning, the correct fit of the filter and the seals must be checked.

Important information

- ▶ The sample gas probe is a system/project-specific external functional unit (option). For commissioning, observe the Operating Instructions / Installation Instructions for the gas sampling probe.
- ▶ Wait for the heating up time for the gas sampling probe to end (duration: approx. 2 hours).
- ▶ Check the set point adjustment on the built-in thermostat or on the external controller. The set points can be found in the wiring diagram.
- ▶ Make sure the built-in ball valve is closed on gas sampling probes with ball valve (option).
- ▶ If there is excess pressure in the process, the pressure of the back purge line must be monitored when using an SP3200 gas sampling probe. The pressure in the back purge line must always be higher than the process pressure. A corresponding signal can be fed in as a binary signal (pressure OK/NOK) at the Smoldering Fire Detection System. Details on the connection can be found in the wiring diagram.

5.6 Sampling Point Switching and Gas Paths

Open the ball valves (-QM1 to -QM4) after the warm-up phase of the Smoldering Fire Detection System (internal components, sample gas lines and sampling probes) and before activating the measuring mode.

5.7 Restart After a Longer Shutdown

Restarting after a longer shutdown (several weeks) requires the cooperation of service technicians with the planning engineers responsible for the plant environment.

- ▶ Contact SICK Customer Service to clarify individual precautionary measures required for a restart after a longer shutdown (several weeks).
- ▶ Ensure the following as preparatory work for clarification:
The system and the system components must be checked for operational readiness in accordance with the instructions for commissioning and maintenance as described in these Smoldering Fire Detection System Operating Instructions and the Operating Instructions for the system components.

System components	Check
Lines / tubing	Condensate-free, blocked, dirty, cracks, porous, brittle, tight and proper fit
Filter	Condensate-free, contamination-free, ready for operation Note: In case of discoloration, the filter elements
Sample gas pump	Ready for operation
Water trap	Condensate-free (replace water trap if necessary) Note: If condensate is present, then the water trap blocks and must be replaced
Analyzer	Ready for operation
Gas cooler	Ready for operation
Reference gases	Expiration date, remaining volume, pressures
Cabinet air conditioning	Ready for operation
Gas monitor / gas computer	Ready for operation
Detonation flame arrester	Ready for operation (check for contamination)
Condensate container with level switch	Ready for operation (empty if necessary)
Sample gas outlet / sample gas recirculation	Free from blockages
Sampling probe	Ready for operation
External components and signal generators	Ready for operation

In addition to this list, also observe the information and conditions for particular system components in Sections “Commissioning” and “Maintenance” in these Smoldering Fire Detection System Operating Instructions.

Refer to the Operating Instructions for the individual system components for further details and information.

6 Operation

6.1 Operating the System Components

The Smoldering Fire Detection System is a low-maintenance measuring system that functions in a self-monitoring manner. Information on operation can be found in the Operating Instructions for the individual system components, as described in these Operating Instructions.

6.2 Layout and Functions of System Components

The layout and function of the individual system components in the Smoldering Fire Detection System can be found in the relevant wiring diagram.

6.3 System Parameters

For details on the system parameterization of the Smoldering Fire Detection System, see the system documentation and the wiring diagram.

6.4 Sampling Point Switching

The Smoldering Fire Detection System has sampling point switching, with which up to 4 sampling points can be switched.

Only one sampling point can be selected at a time.

The other sampling points continue to be extracted by the second sample gas pump. This prevents any condensate from settling.

Operation is via a selection switch on the door of the Smoldering Fire Detection System.

This selection switch has five positions:

0 = Automatic mode. The sampling points are changed according to a fixed time scheme in a fixed sequence.

1 = Measurement on sampling point 1. No automatic change of the sampling point.

2 = Measurement on sampling point 2. No automatic change of the sampling point.

3 = Measurement on sampling point 3. No automatic change of the sampling point.

4 = Measurement on sampling point 4. No automatic change of the sampling point.

The assignment of the sampling points is shown in the respective gas flow diagram.

The changeover time in automatic mode is determined on a project-specific basis and documented in the wiring diagram.

Sampling points may only be exhausted over a longer period without measurement when it is ensured that no ignitable gases or gas-dust mixtures are suctioned in.

Sampling points that are not in operation must be shut off via ball valves QM1 - QM4.

7 Adjustment

NOTE

Only qualified personnel from the relevant specialist areas may carry out work on the system.

7.1 Necessary Adjustment

- After commissioning
- At regular intervals during operation (recommended: Weekly to monthly).
- The specific adjustment cycles depend on the application and are not the responsibility of SICK AG.

7.2 Variants of the adjustment Procedure

System-specific variants of the Smoldering Fire Detection System can be found in the wiring diagram of the project documentation.

The adjustment can be controlled automatically or manually:

- Automatic adjustment
- Depending on the analyzer, calibration can be performed with external reference gases, with an internal calibration cuvette and / or ambient air
- Further details on the description of the adjustment variants can be found in the Operating Instructions of the corresponding analyzer

7.3 Carrying Out the Adjustment Procedure

Details on how to carry out or the description of the respective adjustment of the analyzer can be found in the Operating Instructions of the corresponding analyzer and the wiring diagram of the Smoldering Fire Detection System.

General information on adjustment

- Reference gases must be connected or supplied in the specified concentrations as well as with the specified maximum pressures
- The test gas waiting time and the adjustment measuring interval must be taken into account for the specific application. (e.g. consideration of the line length)

Information on automatic adjustment

- ▶ The factory settings for the start time and the time interval of the automatic adjustment starts must be adapted to the system/project-specific conditions.
- ▶ The factory settings for the test gas waiting time and the adjustment measuring interval must be adapted to the application-specific conditions.

7.4 Adjustment (Calibration) of External Components and Signal Transmitters

External components and signal transmitters connected to the Smoldering Fire Detection System or powered by the Smoldering Fire Detection System must be adjusted or calibrated according to individual component characteristics and applications, independent of the Smoldering Fire Detection System.

8 Decommissioning

NOTE

Only qualified personnel from the relevant specialist areas may carry out work on the system.

- ▶ Adhere to occupational safety measures and sequence of instructions.



DANGER

Toxic gases.

Severe poisoning or death by inhalation.

- ▶ Operate the system in adequately vented areas or rooms.
- ▶ Check permanent fan. Only enter contaminated rooms with PPE (respiratory equipment, gas warning detector).
- ▶ Check hose connections and screw fittings. Perform regular leak tests with leak detection spray and leak tester.
- ▶ Safely discharge gas outlets of the measuring medium.
- ▶ Observe all local laws, technical rules and operator instructions.



WARNING

Toxic condensate liquid.

Serious injuries and harmful to the environment.

- ▶ Wear suitable personal protective equipment (PPE).
- ▶ Only open the condensate container in well-ventilated rooms.
- ▶ Safely drain condensate.
- ▶ Disposal in accordance with applicable local environmental regulations and guidelines.

8.1 Stand-By Mode - Maintenance Mode

In stand-by mode, long restart times can be avoided in the event of interruptions in measuring operation for carrying out maintenance work.

This stand-by state is achieved by stopping the sample gas delivery by putting the sample gas pump out of operation. For this purpose, the »Maintenance« status output must be activated via the menu function on the analyzer.

Refer to the Operating Instructions of the analyzer for details on operation and relevant menu functions.

When the menu function Maintenance per analyzer is activated, the sample gas pump is automatically switched off and a possible external body is informed via a maintenance signal that the Smoldering Fire Detection System is not in regular measurement operation and the pending measurement signals are therefore implausible.

After switching off the sample gas pump, the ball valves (-QM1 to -QM4) must be closed.

Note

The Smoldering Fire Detection System is equipped with an optional maintenance switch, depending on the individual system. If the Maintenance operating mode is activated via this maintenance switch, the function of the sample gas pump is not deactivated but only the maintenance signal is transmitted to a possible external body.

8.2 Decommissioning

8.2.1 Safety Measure: Secure Connected Systems

- ▶ Decommissioning of the Smoldering Fire Detection System / gas analyzer could affect external systems. If necessary, inform the affiliated external systems.
- ▶ Check if any automatic emergency measures could be triggered when decommissioning the analyzer. It may be necessary to consider which switching logic is used for the switching outputs of the Smoldering Fire Detection System / gas analyzer.
- ▶ Observe the Operating Instructions of the gas analyzer.
- ▶ If a data processing system is connected, it may be required to manually indicate a planned shutdown, so that the system will not interpret the shutdown as an Smoldering Fire Detection System malfunction.

8.2.2 Safety Measure: Remove the Sample Gas Completely

If the Smoldering Fire Detection System has been used to measure toxic, hazardous or humid gases, gas paths and components carrying the sample gas must be thoroughly purged with a neutral gas before decommissioning.

- ▶ Purge all gas paths of the Smoldering Fire Detection System including the external sample gas lines for a few minutes with a "dry" neutral gas - e.g. nitrogen (technical).
- ▶ Consider the maximum allowable sample gas pressure of the analyzer when purging with a neutral gas. The applicable maximum sample gas pressure can be found in the Operating Instructions or Data Sheet of the analyzer.

- ▶ Taking into account the application and the ambient conditions, it can be checked whether purging with ambient air is possible. In this case, it is sufficient to let the system suction in ambient air on the sample gas probe side for a few minutes (if necessary, the sample gas probe must be pulled out of the duct for this purpose).
Attention! Observe application conditions and safety instructions.
- ▶ Afterwards, stop the sample gas feed and close off all gas connections of the Smoldering Fire Detection System or close off the relevant valves in the purged gas path. The sample gas supply (or the sample gas suction) can be interrupted by switching off the sample gas pumps / analyzers or via a corresponding manual menu function of the analyzer.
Refer to the Operating Instructions of the relevant analyzer for details on operation and menu functions.

Note

Recommendation: Activate the Maintenance status output using the menu function via the analyzer. This switches off the sample gas pump and signals to a possible external body via the maintenance signal that the Smoldering Fire Detection System is not in regular measuring operation.

8.2.3 Measurement of Harmless Gases

Note

For clarification or classification of the sample gas as a harmless medium, contact the plant operator or SICK Customer Service in case of doubt.

- ▶ Stop the sample gas feed to the Smoldering Fire Detection System.
Stop sample gas pumps / analyzers. Use the manual menu function of the analyzer and close existing shut-off fittings.
Details on the operation of the analyzers can be found in the corresponding Operating Instructions.

Recommendation:

Activate the "Maintenance" status output via the menu function on the analyzer. This switches off the sample gas pump and signals to a possible external body via the maintenance signal that the Smoldering Fire Detection System is not in regular measuring operation.

- ▶ Disconnect the Smoldering Fire Detection System from the external sample gas paths. This prevents the sample gas and test gas from flowing into the Smoldering Fire Detection System.
- ▶ Close all gas connections, lines and valves.

8.2.4 Switching Off

- ▶ Switch the Smoldering Fire Detection System off using the main switch.

Note

Smoldering Fire Detection System with control cabinet-cooling unit (option):

- ▶ When switching the Smoldering Fire Detection System on/off, observe the minimum switch-off times of the control cabinet cooling unit.
If not observed, the control cabinet cooling unit may be damaged.
- ▶ Refer to the specific Operating Instructions of the control cabinet cooling unit for the recommended minimum switch-off time.

8.3 Shutdown

- ▶ Disconnect the Smoldering Fire Detection System completely from the power supply.
- ▶ Disconnect the sample gas line and probe from the system.
- ▶ Dispose of the condensate.
Acidic condensate: Observe personal protective measures, local and legal requirements for disposal.
- ▶ Close off the gas inlet / outlet on the analyzer.
- ▶ Close off the end of the sample gas line on the probe side.
- ▶ Dismantle the sample gas probes and close off the connections with dummy flanges.
- ▶ Disconnect or close other optional connections (e.g. instrument air, water connections, connections for condensate discharge).

8.4 Storage

Storage conditions

- Indoors.
- Ambient temperature: -20 - +55 °C
- Relative humidity: Max. 80% (without condensation)
To prevent condensation: Carefully flush internal sample gas paths with a dry, neutral gas before decommissioning
- Store in a dry place

9 Maintenance

NOTE

Only qualified personnel from the relevant specialist areas may carry out work on the system.



DANGER

Explosion hazard with explosive sample gas.

Serious injuries and death.

- ▶ Do not feed explosive sample gas.



DANGER

Toxic gases.

Severe poisoning or death by inhalation.

- ▶ Operate the system in adequately vented areas or rooms.
- ▶ Check permanent fan. Only enter contaminated rooms with PPE (respiratory equipment, gas warning detector).
- ▶ Check hose connections and screw fittings. Perform regular leak tests with leak detection spray and leak tester.
- ▶ Safely discharge gas outlets of the measuring medium.
- ▶ Observe all local laws, technical rules and operator instructions.



WARNING

Hot surfaces.

Serious injury from hot surfaces on probes, filters, and heated sample gas lines.

- ▶ Protect hot surfaces against contact.
- ▶ Wear protective gloves.



WARNING

Toxic condensate liquid.

Serious injuries and harmful to the environment.

- ▶ Wear suitable personal protective equipment (PPE).
- ▶ Only open the condensate container in well-ventilated rooms.
- ▶ Safely drain condensate.
- ▶ Disposal in accordance with applicable local environmental regulations and guidelines.

9.1 Maintenance Signal

Before carrying out maintenance work on the Smoldering Fire Detection System, the ball valves (-QM1 to -QM4) must be closed.

When the maintenance signal is manually activated, an external body is signaled that the Smoldering Fire Detection System is not in regular measuring operation.

Depending on project planning and design, activation takes place via the menu function on the analyzer or via a separate maintenance switch.

Design and details can be found in the Operating Instructions of the corresponding analyzer or in the wiring diagram.

When the "Maintenance" operating mode is activated via the menu function on the analyzer, the sample gas pumps are automatically switched off.

A possible external body is informed via the maintenance signal that the pending measuring signals are therefore implausible.

If the »Maintenance« operating mode is activated via the optional maintenance switch (system-specific equipment), the function of the sample gas pump is not deactivated but only the maintenance signal is transmitted to a possible external body.

The maintenance signal must be switched off when it is no longer required.

9.2 Visual Inspection/Functional Check

- ▶ Check the operating status of the devices.
- ▶ Make a weekly visual inspection.
- ▶ Regular check for the complete Smoldering Fire Detection System:
 - Screw fittings
 - Hose connections
 - Gas lines
 - Connections of the probe and other system components
 - Check enclosure and condensate pump for damage.

9.3 Maintenance Tasks

9.3.1 Maintenance Recommendations / Intervals

- Maintenance intervals depend on the application.
- Basically, the maintenance recommendations in the respective Operating Instructions of the system components apply. All recommendations are process-dependent and are not the responsibility of SICK
Observe the Operating Instructions of the respective system components.

System components	Description	Recommended maintenance intervals		
		Week	Month	Year
Gas sampling probe (option)	Check filters and seals. Change the filter regularly depending on the load. Observe the Operating Instructions of the gas sampling probe.		X	
Sample gas line (option)	Check heating function. Clean at regular intervals: Observe the relevant Operating Instructions.		X	
Filter (option)	Check condition/contamination level of the filters (depending on the application, the stress on the filters may vary). Check for condensate in filter housing bottom. Drain off condensate when necessary. Observe Operating Instructions/Data Sheets.	X		
Sample gas pump (option)	Replace the water trap at least once a year. Note: If condensate occurs in the water trap, it is blocked and must be replaced. In this case, the system reports “System error” because the gas flow has been interrupted.			X
Cabinet vent filter fan (option)	Function test of filter fan. Clean heavily contaminated filter pads and replace as necessary. Define the filter pad replacement interval individually depending on the amount of dust and the operating time. Attention: Change the filter in good time. A dirty filter pad increases the temperature in the control cabinet. Clean filter pads by flushing or blowing. Observe the Operating Instructions of the filter fan.		X	
Cabinet thermostat (option)	Check function in connection with the filter fan.		X	
Condensate container with level switch	Check the condition of the container. Empty the container if necessary. (Warning message) Note: Condensate is hazardous waste. Observe the regulations. Attention: Acidic liquid. Observe the regulations.		X	

System components	Inspection recommendations / description of maintenance
Sample gas cooler (including condensate pump)	<p>Check enclosure and condensate pump for possible damage. Replace the optionally fitted Teflon filter cartridge at regular intervals, depending on wear and degree of contamination. Regulate the refrigerant condenser regularly, depending on the degree of contamination. Replace the hoses of the condensate pump regularly, depending on wear. At least 1 time per year. Recommendation, replace the hoses every 3 months as a preventive measure. Attention: The condensate can be acidic. Check of screw fittings / connections. Note: Observe the Operating Instructions of the sample gas cooler.</p>
Condensate pump	<p>Check enclosure and condensate pump for possible damage. Replace the hoses of the condensate pump regularly, depending on wear. At least 1 time per year. Recommendation: Replace the hoses every 3 months as a preventive measure. Attention: The condensate can be acidic. Check of screw fittings / connections. (Note: Observe the Operating Instructions of the condensate pump).</p>
Analyzer	Observe the Operating Instructions of the analyzer.
Gas monitor/ Gas measurement computer (option)	<p>Have it tested with test gas at regular intervals by skilled Service personnel. Note: Observe the Operating Instructions of the gas monitor. Attention: The operator must check on site the limit or threshold values (alarm thresholds) set at the factory and adapt these to local conditions. Observe the relevant regulations, safety instructions and laws for monitoring toxic gases and / or the LEL.</p>
Gas detection system	<p>Recommendation: Conclude a maintenance contract with the Service department of the device manufacturer. Note: In case of an alarm, sample and test gas feed are interrupted and a visual as well as acoustic warning message triggered</p>
Tubing Hoses	<p>Check for:</p> <ul style="list-style-type: none"> - Blockages, contamination, cracks - Porous or brittle condition - Tight and correct fit - Clean or exchange when necessary.
Cabinet cooling unit (option)	Observe the Operating Instructions of the respective system components.
Reference gases (option)	<p>Check state and availability of reference gases at regular intervals: For example: Delivery pressure from the central gas supply, remaining quantity in the gas cylinders, expiration date. (Option: Monitor cylinder pressure with contact pressure gauge.)</p>

9.4 Cleaning Information

- ▶ Do not use any mechanically or chemically aggressive cleaning agents.
- ▶ Do not allow any liquids to penetrate the control cabinet or housings of system components.
- ▶ Clean the outside and inside only with a soft cloth.

9.5 Condensate Container

Description

During operation, condensate forms due to the cooling of the sample gas. The condensate can be toxic and corrosive. The condensate and the entrained sample gas are drained into the condensate container. When the container is full, a capacitive proximity sensor gives the signal to empty it.

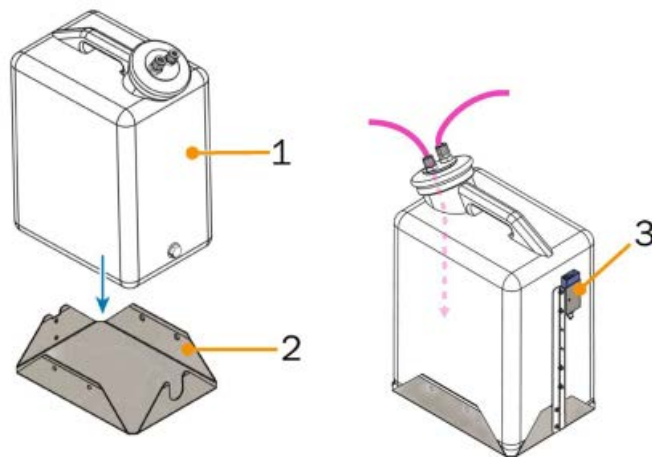

Fig. 3: Condensate container, metal bracket (2) and proximity switch (3)

Legend	
1	Condensate container
2	Metal bracket
3	Proximity switch

Note

If the personnel have not emptied the container in less than 48 hours, the system sends an error signal and stops the measurement.

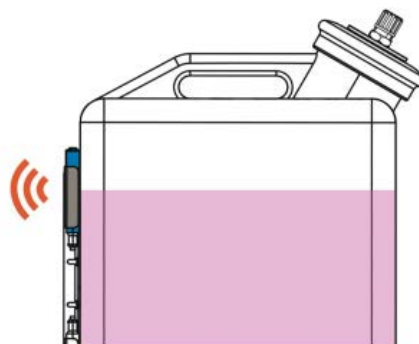

Fig. 4: Proximity switch at condensate container

9.6 Recommended Wear Parts (WP) and Spare Parts (SP)

Note

- Wear and spare parts are analyzer and application dependent.
- The service life of wear parts depends on the application.
- ▶ Store parts in a dry, ventilated area protected against dust.
- ▶ Avoid long storage times.

Sample gas filter / SICK filter					
Description	Part No.	Used in:	WP	SP	Demand per year
Filter diaphragm made of glass fiber 55 mm diameter Sales unit = 25 pcs.	5312005	Front fitted filter FI56NK3 (2028590) ext. filter	X		1 pc./ 1 y.
Safety filter FI64 glass, 1µm for hose Di = 4 mm	2027973	S711		X	1 pc./ 2 y.
Water trap WT20.5K	5313317	Water trap		X	1 pc./ 2 y.
Filter element (front panel)	5317730	(2028590) FI56NK3 front fitted filter Diaphragm fine filter	X		1 pc./ 1 y.

Sample gas filter / Bühler					
Description	Part No.	Used in:	WP	SP	Demand per year
Filterelement S2(glassfiber)2µm Sales unit = 5 pcs.	5312243	Fine filter AGF-PV-30-S2 (5312425)	X		1 pc./ 1 y.
Filter element F2L (PTFE) 2µm Sales unit =1 pc.	5317771	Fine filter AGF-PV-30-F2L (0730459)	X		1 pc./ 1 y.
Filter element F25 (PTFP) 25µm Sales unit = 5 pcs.	5311943	Fine filter AGF-PV-30-F25 (5312424)	X		1 pc./ 1 y.
Filterelement F25L(PTFE)25µm Sales unit = 1 pc.	0026797	Fine filter AGF-PV-30-F25L (0026796)	X		1 pc./ 1 y.
Filterelement F2(PTFE)2µm Sales unit = 5 pcs.	5322649	Fine filter AGF-T-30-F2 (5312703)	X		1 pc./ 1 y.
Filter element DRG25 VA-V (1.4301) 25µm Sales unit = 5 pcs	5312687	Fine filter AGF-VA-23V (5312686)	X		1 pc./ 1 y.
Filterelement 12-57-C(borosilicatefiber) Sales unit=1 pc.	5312319	Coalescence filter K-AGF- PV-30-A (5317088)	X		1 pc./ 1 y.

Filter pad for cabinet fan					
Description	Part No.	Used in:	WP	SP	Demand per year
Replacement filter pad for outlet filter and filter fan WxHxD 173 x 173 x 17	5306678	Outlet filter SK3323.xxx (5315501)	X		As required
Replacement filter pad for outlet filter and filter fan WxHxD 173 x 173 x 17	5308584	Outlet filter SK3326.xxx (5314520)	X		As required

Sample gas pump KNF					
Description	Part No.	Used in:	WP	SP	Demand per year(s)
Spare parts set for pump N86KT.18 comprising: 1 pc. structure diaphragm, 2 pcs. valve plate, 2 pcs. sealing ring	5312317	Sample gas pump	X		1 pc./ 1 y.
Sample gas pump, complete N86 KT.19 231 VAC, in housing, flow rate approx. 250 l/h	7027252	Sample gas pump		X	1 pc./ 3 y.

Analyzer S711					
Description	Part No.	Used in:	WP	SP	Demand per year(s)
SP set power plug combination element 1 device plug element 1 protective cover, 1 drawer 2 miniature fuses 5x20, M 4.0A 2 miniature fuses 5x20, M 2.0A	2028437	S711		X	1 pc./ 2 y.
Safety filter FI64Glas, 2 µm, for hose Di=4 mm	2027973	S711		X	1 pc./ 2 y.
Spare part - set pump parts TYP123 Diaphragm set EPDM/ozone-resistant with 4 rings for suspension	2028438	S711		X	1 pc./ 2 y.

Sample gas cooler AGT (MAK10)					
Description	Part No.	Used in:	WP	SP	Demand per year(s)
Spare filter cartridge, Teflon	5320090	Sample gas cooler MAK10	X		1 pc./ 2 y.
Hose pump SR25, complete 115/230 V, 50/60 Hz, IP00, 5 rpm. 1 duct, 2 rolls on assembly bracket Novopreme hose 4.8x1.6 - 0.4 l/h with 2 hose connections 5 mm 115/230 V 50/60 Hz IP00, 5 rpm, including Novopreme hose and 2 hose connections	6039473	Sample gas cooler MAK10		X	1 pc./ 2 y.
Spare parts set hose pump SR2: comprising: 5 pcs. pump hose 4,8x1.6 Novopreme, 1 pc. wrapping tape roll	2050587	Sample gas cooler MAK10	X		1 pc./ 2 y.

Condensate pump SR25					
Description	Part No.	Used in:	WP	SP	Demand per year(s)
Hose pump SR25 complete 115/230 V, 50/60 Hz, IP00, 5 rpm. 1 channel, 2 rollers on mounting bracket Hose 4.8x1.6 Novopreme - 0.4 l/h with 2 hose connections 5mm	6027131			X	1 pc./ 2 y.
Spare parts set hose pump : SR25 comprising: 5 pcs. pump hose 4.8x1.6 Novopreme, 1 pc. wrapping tape roll	2027976	Hose / condensate pump SR25	X		3 pcs./ 2 y.
Hose pump type SR25 5 UPM 5 UPM / N4.8x1.6 239/115 V, 50-60 Hz	6026412			X	1 pc./ 2 y.
Hose pump type SR25 1 230 V / 50 Hz; 115 V, 60 Hz (01P1000)	6021783			X	1 pc./ 2 y.



For further information on wear and spare parts of the Smoldering Fire Detection System, see the system documentation, the data sheets and the Operating Instructions of the respective system components.

10 Troubleshooting

NOTE

Only qualified personnel from the relevant specialist areas may carry out work on the system.

10.1 Fuses

- ▶ Check condition of fuses. Details can be found in the wiring diagram, the Operating Instructions and the data sheets of the system components.

10.2 Status Display / Group Malfunctions

Displayed and output error messages:

- Generation of a group malfunction of the Smoldering Fire Detection System (details see wiring diagram)
- Status information on the analyzer display.
(Display messages, meaning, cause / notes and service instructions, see analyzer Operating Instructions).
- Status information / plain text message on the display of the LOGO! control

10.3 Implausible Measurement Results

Checks in case of implausible measurement results:

- ▶ Predefined and elementary process conditions adhered to
- ▶ Possible leaks in the sample gas path

Further possible causes and notes can be found in the Operating Instructions of the analyzer.

10.4 Switch-On Conditions

Switch-on conditions have been set at the factory for the Smoldering Fire Detection System. These are used for safety or function monitoring of certain analyzer system components and are realized by signal status queries of these components.

Depending on the version of the analysis system, status signal queries run either via:

- A signal series connection
- The analyzer
- The LOGO! control
- A PLC control

The specific parameterization and execution of the switch-on conditions can be found in the wiring diagram of the Smoldering Fire Detection System.

Note

The factory-configured switch-on conditions must not be decommissioned. Failure to observe or disable the switch-on conditions can cause serious damage.

10.4.1 Status Parameters of the Switch-On Conditions

- **Gas sampling probe** (option)
Set point temperature monitoring of heated gas sampling probes (option).
Monitoring is performed by an under temperature alarm contact integrated in the sample gas probe.
When the set point setting is complied with, a status signal is enabled to fulfill the switch-on conditions.
Depending on the type of probe and the design of the system, the adjusted value setting or the set value setting to be adjusted is listed in the wiring diagram of the Smoldering Fire Detection System or in the Operating Instructions of the sample gas probe.
- **Sample gas line** (option)
Heating function monitoring of controlled heated sample gas lines (option).
When the set point setting is complied with, a status signal is enabled by the temperature controller to fulfill the switch-on conditions.
The set point settings are system-specific and are listed in the wiring diagram of the Smoldering Fire Detection System.
- **Sample gas cooler**
Function monitoring of the cooler (status query).
If there is no cooler malfunction, a status signal is enabled after reaching the operating temperature (cooling temperature) to fulfill the switch-on condition.
- **Level sensor**
Monitoring of the level in the condensate collection tank.
As long as the specified maximum level of the condensate collection tank has not been reached, a status signal is enabled to fulfill the switch-on condition.
- **Analyzer**
For failure monitoring of the analyzer or for monitoring / querying the self-diagnostic function (for internal monitoring parameters such as, for example, temperature, flow rate, humidity), a status signal is either routed to a floating signal terminal, or can be evaluated by it when using a LOGO! / PLC control (optional).
- **Pump function**
The pump function of the sample gas pump is controlled by the analyzer.
By controlling (operating) the sample gas pump, a status signal is released to fulfill the switch-on condition. When using a LOGO! / PLC control (optional), the pump function (gas flow) can be additionally monitored by it.

11 Leak Test

Note

Only qualified personnel from the respective field are permitted to work on the system.
Perform leak test at regular intervals.

Note on leak testing of hot extractive systems

Allow system to cool to ambient temperature before testing.

Recommended device: Testo 324 Leakage rates measuring instrument.
Not included in SICK scope of delivery.



Fig. 5: Testo 324 - Leakage rates measuring instrument



For more information about the Testo 324 Leakage rates measuring instrument, refer to the corresponding Testo Instruction manual.

11.1 Preparing the Test

The sample gas path generally consists of:

Sample gas inlet - sample gas valve - cooler - pump - analyzer - sample gas outlet.

- ▶ Close the sample gas supply (pump) of the cooler.
- ▶ Close the measuring outlet.
- ▶ Connect the Testo 324 Leakage rates measuring instrument to the sample gas inlet.
- ▶ All tests must be documented.
- ▶ To protect the Testo 324, all lines must be free of oil, dust and moisture.

0.31 Leak Test

During the pressure test, all pipes and hoses up to the gas appliances must be tested for leaks at an overpressure of must be tested for leaks at an overpressure of 150 mbar with air or helium. The pipelines are considered to be tight if, after temperature equalization, the test pressure does not drop more than $\Delta p < 25$ mbar during the subsequent test period of 10 min.

NOTICE

If a leak is detected in gas-carrying lines with a gas detector or with foam-forming agents in accordance with DIN EN 14291, the location must be sealed by suitable measures.

Type	Value
Stabilization time	1 minute
Measuring time [T_{target}]	10 minutes
Test pressure	150 mbar
Permissible pressure drop / time [$\Delta p/T$]	< 25 mbar / 10 minutes

0.42 Perform Leak Test

1. Start measurement:
 - The pressure (target) is built up automatically by the device Testo 324.
 - Zeroing starts (5 sec.)
2. Evaluate measurement result:
 - Measurement result is displayed.
3. Document and save the measurement result in the test log.

12 Specifications

12.1 Conformities

The technical version of this device complies with the following EU directives and EN standards:

- EC Directive: LVD (Low Voltage Directive)
- EC Directive: EMC (Electromagnetic Compatibility)
- EC Standard 61439

For further information refer to the declaration of conformity.

12.2 Technical data

Technical data	Smoldering Fire Detection System
Versions	<ul style="list-style-type: none"> Standard version Cabinet air conditioner and/or heater (option)
Analyzer	<ul style="list-style-type: none"> Gas analyzer S700 (see product information)
Possible measuring components	CO, O2 (depending on the analyzer, see system documentation)
Output and status signals	4 ... 20 mA (depending on the analyzer, see system documentation)
Sample conditions	
Sample gas throughput	30 ... 100 l/h (higher sample gas flow rate possible, depending on the system)
Sample gas temperature	Max. 200 °C at the cabinet inlet
Dew point H2O	Max. 65 °C
General data	
Conditions at the installation site	<ul style="list-style-type: none"> Under roof, with protection against direct heat radiation, strong dust exposure and corrosive atmosphere Not suitable for potentially explosive atmospheres
Auxiliary power	Information on rated current/voltage/power can be found in the system-specific wiring diagram or the system documentation. Possible variants: <ul style="list-style-type: none"> 400 V, 50 Hz/60 Hz (optional) UPS (optional)
Frost protection heating (option)	Rated output 500 VA
Ambient temperature during operation:	+5 ... +35 °C (no direct sunlight) +5 ... +50 °C with built-in air conditioner
Transport and storage temperature	-20 ... +55 °C
Relative humidity	Class F (DIN 40040), 75% annual average, 95% short-term, non-condensing
Sample gas pump	<ul style="list-style-type: none"> Pump (internal) in analyzer conditionally sufficient up to 15 m sample gas line Pump (external) in Smoldering Fire Detection System analyzer cabinet (option) conditionally sufficient up to 35 m sample gas line (optionally longer lengths with more powerful pumps possible)
Dimensions (W x H x D)	See view drawings or wiring diagram of the system documentation.
Enclosure rating, indoor	<ul style="list-style-type: none"> IP54 IP34 with cooling unit
Enclosure rating, outdoor	<ul style="list-style-type: none"> IP65 (GRP cabinet) with outdoor air conditioner: NEMA 3R/4
Weight	Approx. 250 to 350 kg
Material	<ul style="list-style-type: none"> Sheet steel enclosure GRP enclosure:
Color	RAL 7035 (standard, other colors optional)
Calibration	<ul style="list-style-type: none"> Automatic test gas feed (depending on analyzer)
Signals	1 analog output/components
Interfaces	<ul style="list-style-type: none"> RS232 (optional)

13 Disposal

Note

Only qualified personnel from the relevant specialist areas may carry out work on the system.

Only qualified personnel may shut down, decommission, transport and dispose of the equipment.

Note

Observe the relevant valid local and statutory environmental regulations and directives for the disposal of industrial and electronic waste.



WARNING

Toxic condensate liquid.

Serious injuries and harmful to the environment.

- ▶ Wear suitable personal protective equipment (PPE).
- ▶ Only open the condensate container in well-ventilated rooms.
- ▶ Safely drain condensate.
- ▶ Disposal in accordance with applicable local environmental regulations and guidelines.

Disposal of batteries, electric and electronic devices

In accordance with international directives and regulations, batteries, rechargeable batteries as well as electric or electronic devices may not be disposed of with the household waste.

The owner is required to dispose of the devices at the end of their service time via the relevant public collection points.

This symbol on the packaging or in this document indicates that a product is subject to these regulations.



The following assemblies could contain substances that have to be disposed of separately:

- **Electronics:** Capacitors, rechargeable batteries, batteries
- **Displays:** Liquid in the LCD displays
- **Air conditioners:** Observe manufacturer and local instructions and dispose of accordingly.
- **Sample gas lines:**
Toxic materials in the sample gas can be absorbed or trapped in the soft gas path material (e.g. hoses, sealing rings). Such effects have to be considered during disposal.
- **Gas analyzers**



Detailed information on the disposal of analyzers can be found in the corresponding Operating Instructions.

8029878/1PLT/V2-0/2024-10

www.addresses.endress.com
