

Operating Instructions

TRANSIC151LP

Laser Oxygen Transmitter



Described product

Product name: TRANSIC151LP
Variants: TRANSIC151LP-A (in-situ measurement)
TRANSIC151LP-B (ambient gas measurement)
TRANSIC151LP-C (extractive measurement)
TRANSIC151LP-F (in-situ measurement)
TRANSIC151LP-G (in-situ measurement)
TRANSIC151LP-H (in-situ measurement)

Manufacturer

Endress+Hauser SICK GmbH+Co. KG
Bergener Ring 27
01458 Ottendorf-Okrilla
Germany

Place of manufacture

Endress+Hauser SICK GmbH+Co. KG
Poppenbütteler Bogen 9b
22399 Hamburg
Germany

Legal information

This work is protected by copyright. Any rights derived from the copyright shall be reserved for Endress+Hauser SICK GmbH+Co. KG. Reproduction of this document or parts of this document is only permissible within the limits of the legal determination of Copyright Law. Any modification, abridgment or translation of this document is prohibited without the express written permission of Endress+Hauser SICK GmbH+Co. KG. The trademarks stated in this document are the property of their respective owner.

© Endress+Hauser SICK GmbH+Co. KG. All rights reserved.

Original document

This document is an original document of Endress+Hauser SICK GmbH+Co. KG.



Warning symbols



Hazard (general)
Please consult the documentation.



Hazard through electric voltage



Hazard in potentially explosive areas



Hazard through explosive substances/mixtures



Hazard through oxidizing substances



Hazard through noxious substances



Hazard through toxic substances



Hazard through laser radiation



Hazard through high temperature or hot surfaces

Warning levels / signal words

DANGER

Risk or hazardous situation which *will* result in severe personal injury or death.

WARNING

Risk or hazardous situation which *could* result in severe personal injury or death.

CAUTION

Hazard or unsafe practice which *could* result in less severe or minor injuries.

NOTICE

Hazard which *could* result in property damage.

- 1 Important information 8**
 - 1.1 Main operating information..... 8
 - 1.1.1 Installation location..... 8
 - 1.2 Intended use 9
 - 1.2.1 Purpose of the TRANSIC151LP..... 9
 - 1.2.2 Operation in potentially explosive atmospheres..... 9
 - 1.2.3 Approvals 9
 - 1.3 Responsibility of user 10

- 2 Product description 11**
 - 2.1 Product identification 11
 - 2.2 Functional principle/measuring principle 11
 - 2.2.1 TRANSIC151LP probe design 11
 - 2.3 TRANSIC151LP variants 12
 - 2.3.1 Variant for in-situ-measurement..... 12
 - 2.3.2 Variant for extractive measurement..... 13
 - 2.3.3 Variant for ambient gas measurement 14
 - 2.4 Explosion protection according to ATEX and IECEx 15

- 3 Installation 17**
 - 3.1 Project planning..... 17
 - 3.1.1 Chemical tolerance 17
 - 3.1.2 Temperature conditions 17
 - 3.1.3 Strong light sources near the oxygen measuring probe 17
 - 3.1.4 Pressure..... 17
 - 3.2 Information on installation in potentially explosive atmospheres..... 18
 - 3.3 Installation 18
 - 3.3.1 Safety information 18
 - 3.3.2 Prerequisites for assembly 19
 - 3.3.3 Installation angle..... 19
 - 3.4 Installation options 20
 - 3.4.1 Process conditions for installation options 20
 - 3.4.2 TRANSIC151LP installation - in-situ with flange 20
 - 3.4.3 TRANSIC151LP installation - extractive 22
 - 3.4.4 TRANSIC151LP installation - ambient gas measurements 24
 - 3.5 Connections 25
 - 3.5.1 Connecting the TRANSIC151LP transmitter 27
 - 3.5.2 Connecting the TSA151 voltage supply unit 28
 - 3.5.3 Connecting the analog and digital outputs 29
 - 3.5.4 Connecting power supply to the TSA151 voltage supply unit 29
 - 3.5.5 Gas connection (optional)..... 30

4	Operation	31
4.1	Safety instructions for operation	31
4.2	Interfaces	31
4.2.1	Control via keypad	31
4.2.2	Maintenance interface	32
4.2.3	Analog output.....	32
4.2.4	NAMUR digital output	32
4.3	Settings using the keypad	33
4.3.1	Short description: Input of settings using the keypad	33
4.3.2	Safety information on using the password:.....	33
4.4	Menu navigation without password	34
4.4.1	Oxygen statistics (O ₂)	34
4.4.2	Temperature statistics (T)	34
4.4.3	Calibration gas, actual value (CAL.C).....	35
4.4.4	Signal intensity(SIL)	35
4.4.5	Display of active and undeleted errors (ERR).....	35
4.4.6	Entering the password (PAS).....	36
4.5	Menu navigation with password authorization	36
4.5.1	Process pressure: Display and settings (APP)	36
4.5.2	H ₂ O content in the process gas (H ₂ O).....	36
4.5.3	CO ₂ content in process gas (CO ₂).....	37
4.5.4	One-point calibration (CAL1)	37
4.5.5	Two-point calibration (CAL2)	37
4.5.6	Analog output display and settings (AOU)	37
4.5.7	Resetting to the factory calibration (FAC).....	37
4.5.8	Scaling the analog output (ASCL)	38
4.5.9	Digital output (ALA).....	38
4.5.10	Resetting the measuring device (rESE)	38
4.6	Maintenance interface.....	38
5	Setting ambient parameters.....	39
5.1	Compensation of ambient parameters	39
5.1.1	Pressure compensation.....	40
5.1.2	Background gas effects.....	40

6	Adjustment	43
6.1	Hardware preparations.....	43
6.1.1	Setting up the gas supply for calibration and adjustment	44
6.1.1.1	Using ambient air.....	44
6.1.1.2	Using bottled gas and with sample gas cell	44
6.1.2	Calibration and adjustment in the process	45
6.1.2.1	Connections and systems	45
6.1.2.2	Connecting the gas.....	45
6.1.2.3	Adjusting gas flow.....	46
6.1.3	Information on calibration gases.....	46
6.2	Calibration.....	47
6.2.1	Using ambient air	47
6.2.2	Using bottled gas.....	48
6.3	Adjustment.....	49
6.3.1	Adjustment process	49
6.3.2	Adjustment options	49
6.3.3	One-point adjustment using the keypad (function CAL1).....	49
6.3.4	Two-point adjustment using the keypad (function CAL2).....	51
6.4	Adjustment for TRANSIC151LP ambient gas measurement	52
6.4.1	Setting up the gas supply	52
6.4.2	Calibration	53
6.4.2.1	Using ambient air.....	53
6.4.2.2	Using bottled gas	53
6.4.2.3	Information on calibration gases	54
6.4.3	Adjustment	54
6.4.4	Adjustment options	54
6.4.5	One-point adjustment using the keypad (function CAL1).....	55
6.4.6	Restoring factory calibration.....	55
7	Maintenance.....	56
7.1	Field maintenance	56
7.1.1	Assembly and disassembly	56
7.1.1.1	Safety notes	56
7.1.2	Cleaning the optical components.....	57
7.1.3	Checking the temperature probe	59
7.1.4	Cleaning the TRANSIC151LP filter	59
7.1.5	Cleaning the filter	60
7.2	Spare parts and accessories.....	61

8	Troubleshooting	62
8.1	Function errors.....	62
8.1.1	Self-test.....	62
8.1.2	Error control and error categories.....	62
8.1.3	TRANSIC151LP behavior when errors occur.....	62
8.1.4	Error display.....	63
8.1.5	Error Table.....	63
8.2	LED displays on the TSA151.....	64
9	Shutdown	65
9.1	Safety information.....	65
9.2	Preparations for shutdown.....	65
9.3	Switching the TRANSIC151LP off.....	65
9.4	Protecting a shutdown TRANSIC151LP.....	65
9.5	Disposal.....	65
9.6	Shipping the TRANSIC151LP to Endress+Hauser.....	65
10	Specifications	66
10.1	Compliances.....	66
10.2	Ex Approvals.....	66
10.3	Approvals for pressure in Canada.....	67
10.4	Technical Data.....	67
10.4.1	Dimensions and bore patterns.....	67
10.4.2	Measured value recording.....	73
10.4.3	Ambient conditions.....	73
10.4.4	TRANSIC151LP electrical connection.....	74
10.4.5	TRANSIC151LP safety-related technical characteristic data (IECEX/ATEX).....	74
10.4.6	TSA151 voltage supply input.....	75
10.4.7	TSA151 safety-related technical characteristic data (IECEX/ATEX).....	75
10.4.8	Connection lines.....	76
10.4.9	Dimensions and mechanics.....	77
10.4.10	Pressure suitability.....	77
10.4.11	Options and accessories.....	77
11	Annex	78
11.1	Humidity Conversion Table.....	78
11.2	Influence of background gases on oxygen measurement.....	79
11.3	Type code TRANSIC151LP.....	80
11.4	Password.....	81

1 Important information

1.1 Main operating information

Observe the following safety precautions:



CAUTION: The TRANSIC151LP is a protection class 1 laser product (IEC 60825-1:2014-05).

The TRANSIC151LP is eye-safe when used and operated as intended, because laser radiation is retained inside the probe as a bundled beam, as shown schematically on [“Probe design and laser beam guidance within the probe”, page 11.](#)

- ▶ Do not place objects with reflecting surfaces (tools, etc.) directly onto the probe when the TRANSIC151LP is in operation to prevent the laser beam being reflected out of the probe.



NOTICE: Protection against electrostatic discharges

The products are adequately protected against ESD when used as intended.

- ▶ Observe the generally valid ESD regulations to avoid damaging the TRANSIC151LP through electrostatic discharges when touching parts within the enclosure.



WARNING: Hazard through TRANSIC151LP modifications.

Do not remove, add or change any components in or on the device unless such changes are officially allowed and specified by the manufacturer. Failure to observe these precautions could result in

- The manufacturer's warranty becomes void.
- The device could become dangerous.



WARNING: Hazard through device failure

Safe operation of the TRANSIC151LP is questionable when

- The device shows visible damage.
- Moisture has penetrated the device.
- The device has been stored or operated in unallowed ambient conditions.
- The device has been used with a different voltage supply than specified.

If safe operation is no longer possible:

- ▶ Put the TRANSIC151LP out of operation.
- ▶ Disconnect all connections to the power supply.
- ▶ Make sure an unauthorized startup is not possible.

1.1.1 Installation location

The TRANSIC151LP can be used indoors and outdoors.

Altitude: Up to 2000 m above sea level

Max. air humidity: 100% r.h., non-condensing

1.2 Intended use

1.2.1 Purpose of the TRANSIC151LP

The TRANSIC151LP is a stationary oxygen transmitter and serves continuous measurement of oxygen in the industrial sector.

There are 3 variants of the TRANSIC151LP:

1. In-situ measurement
 2. Extractive measurement
 3. Measurement in ambient air
- The TRANSIC151LP is certified for a process-side operating range from 800 mbar(a) to 1400 mbar(a). Usage with deviating pressures can void the Ex certification.
 - The TRANSIC151LP must be operated within the specifications described in the Section Technical Data (see “[Technical Data](#)”, page 67). The Ex certification becomes void when the TRANSIC151LP is operated outside the specifications.
 - The TRANSIC151LP has not been evaluated regarding the safety function as laid out in 94/9/EC, Annex II, Section 1.5.

1.2.2 Operation in potentially explosive atmospheres

The TRANSIC151LP is suitable for the following zones

In accordance with ATEX (EN60079-10) and

in accordance with IECEx (IEC60079-10)

- Gas:
 - Measuring probe: Category 1G EPL Ga (Zone 0)
 - Transmitter / voltage supply unit: Category 2G EPL Gb (Zone 1)
- Dust:
 - Transmitter / voltage supply unit / measuring probe: Category 2D EPL Db (Zone 21)

The TRANSIC151LP may only be used in zones in which either inflammable or explosive gases in groups I, IIA and IIB or inflammable dust in groups IIIA, IIIB and IIIC are present.

- Temperature class:
 - Gas: T4 (max. surface temperature 135 °C)
 - Dust: T85 °C

1.2.3 Approvals

Transmitter		
Gas	- Outside process	II 2G Ex ib IIB T4 Gb
	- Within process	II 1G Ex op is IIB T4 Ga
Dust (<i>alternative</i>)	- Outside process	II 2D Ex ib tb op is IIIC T85 °C Db
	- Within process	II 2D Ex ib tb op is IIIC T85 °C Db
TSA151 voltage supply unit		
Gas		II 2G Ex eb mb [ib] IIB T4 Gb
Dust (<i>alternative</i>)		II 2D Ex tb [ib] IIIC Db

1.3 Responsibility of user

Designated users

All operators of the TRANSIC151LP should be specifically trained on this device, knowledgeable of relevant regulations, and able to assess potential hazards related to its operation.

Correct use



- This Manual presumes that the TRANSIC151LP has been delivered as specified during project planning and the relevant delivery state of the TRANSIC151LP.
 - ▶ Contact Endress+Hauser Customer Service if you are not sure whether the TRANSIC151LP corresponds to the state defined during project planning or to the delivered system documentation. Please contact Endress+Hauser Customer Service.
-

- ▶ Use the device only as described in these Operating Instructions. The manufacturer bears no responsibility for any other use.
- ▶ Carry out the specified maintenance work.
- ▶ Do not remove, add or change any components in or on the device unless such changes are officially allowed and specified by the manufacturer. Failure to observe these precautions could result in
 - voiding the manufacturer's warranty
 - causing the device to become dangerous

Special operating conditions

- TSA151 Power Supply: Protective Extra Low Voltage (PELV) power supply is required. The 24V inlet of the TSA151 is specified with a fault voltage of $U_m=60V$.
- The partition wall thickness of the temperature probe is $0.2 < t < 1$ mm. In order to maintain the zone separation, the temperature probe may not be exposed to corrosive atmosphere that can endanger zone separation.
- The service interface with the Endress+Hauser service interface cable (Part No. 2066710) may only be used outside the Ex area.

Special local conditions

- ▶ Follow all local laws, regulations and company policies applicable at the respective installation location.

Retention of documents

These Operating Instructions:

- ▶ Must be available for reference.
- ▶ Must be conveyed to new owners.
- ▶ Keep passwords in a separate, safe place and secure against unauthorized use.

2 Product description

2.1 Product identification

Product name:	TRANSIC151LP
Manufacturer:	Endress+Hauser SICK GmbH+Co. KG Bergener Ring 27 · D-01458 Ottendorf-Okrilla · Germany

Type plate

The type plate is located on the outer left hand side of the enclosure.

The type plate contains the type code.



CAUTION: Observe marking for special operating conditions

Special operating conditions: Marking "X" on the TSA151 type plate means the 24V input of the TSA151 is specified with a fault voltage of $U_m=60V$ and therefore an appropriate PELV power supply unit is mandatory.

► Observe "Special local conditions", page 10.



The complete type code Table can be found in the Annex, see "Type code TRANSIC151LP", page 80.

2.2 Functional principle/measuring principle

The TRANSIC151LP functions using light absorption of a tunable diode laser (Tunable Diode Laser Absorption Spectroscopy TDLAS). The gas concentration is measured using the damping of a laser beam sent from a tunable diode laser source in the gas sample. For oxygen measuring, the laser beam wavelength is set to match one of the characteristic absorption lines of oxygen in the wavelength range of around 760 nm in the near infrared range (NIR) of the electromagnetic spectrum. During measurement, the diode laser beam wavelength is continuously modulated to scan across one of the oxygen absorption lines. This generates a periodic signal in a photodetector, the amplitude of which is proportional to the amount of oxygen in the laser beam path.



The dust load in the process does not falsify the measured O_2 value. The TRANSIC151LP outputs a maintenance signal when the dust load is too high.

2.2.1 TRANSIC151LP probe design

The sensor is designed as a probe for direct fitting at the measuring location. The diode laser light source, and the photodetector that measures the light, are located in a transmitter behind a protective window. The light is directed onto the photodetector using a focusing mirror at the far end of the probe.

Fig. 1: Probe design and laser beam guidance within the probe

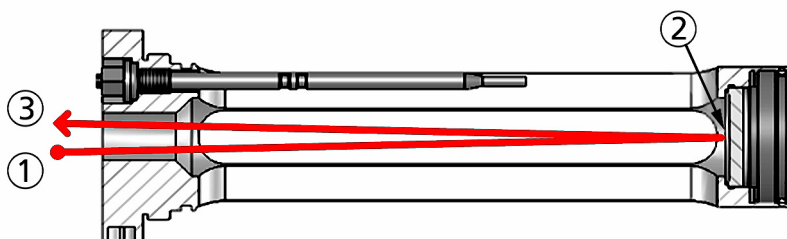

- 1 = Light source
- 2 = Mirror
- 3 = Photodetector

Further information on components having contact with the sample gas probe, see "Pressure suitability", page 77.

2.3 TRANSIC151LP variants

2.3.1 Variant for in-situ-measurement

Fig. 2: Flange mounted TRANSIC151LP-A/-F/-G/-H

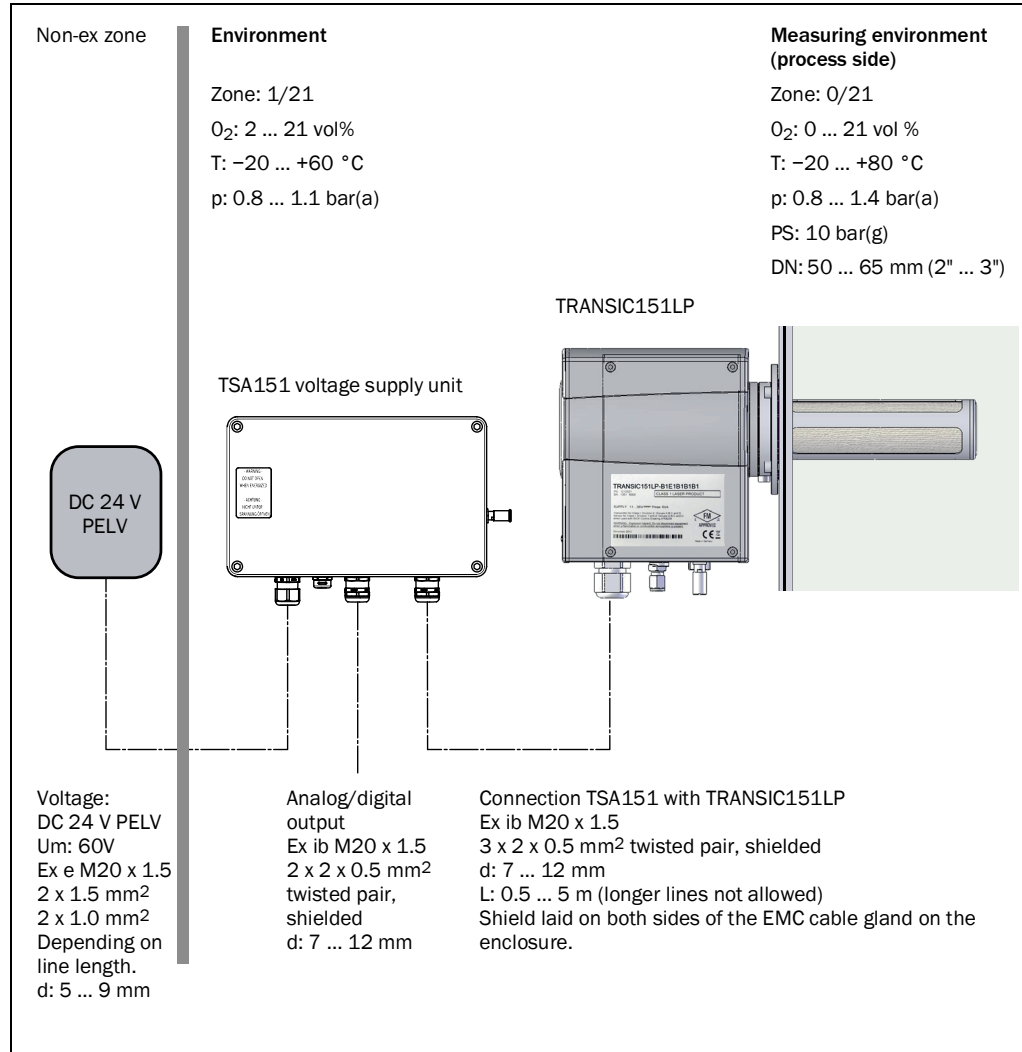

WARNING: Ex certification becomes void for unallowed wiring

► Comply with wiring requirements, see [“Connections”](#), page 25.

2.3.2 Variant for extractive measurement

Fig. 3: TRANSIC151LP-C with sample gas cell and wall bracket

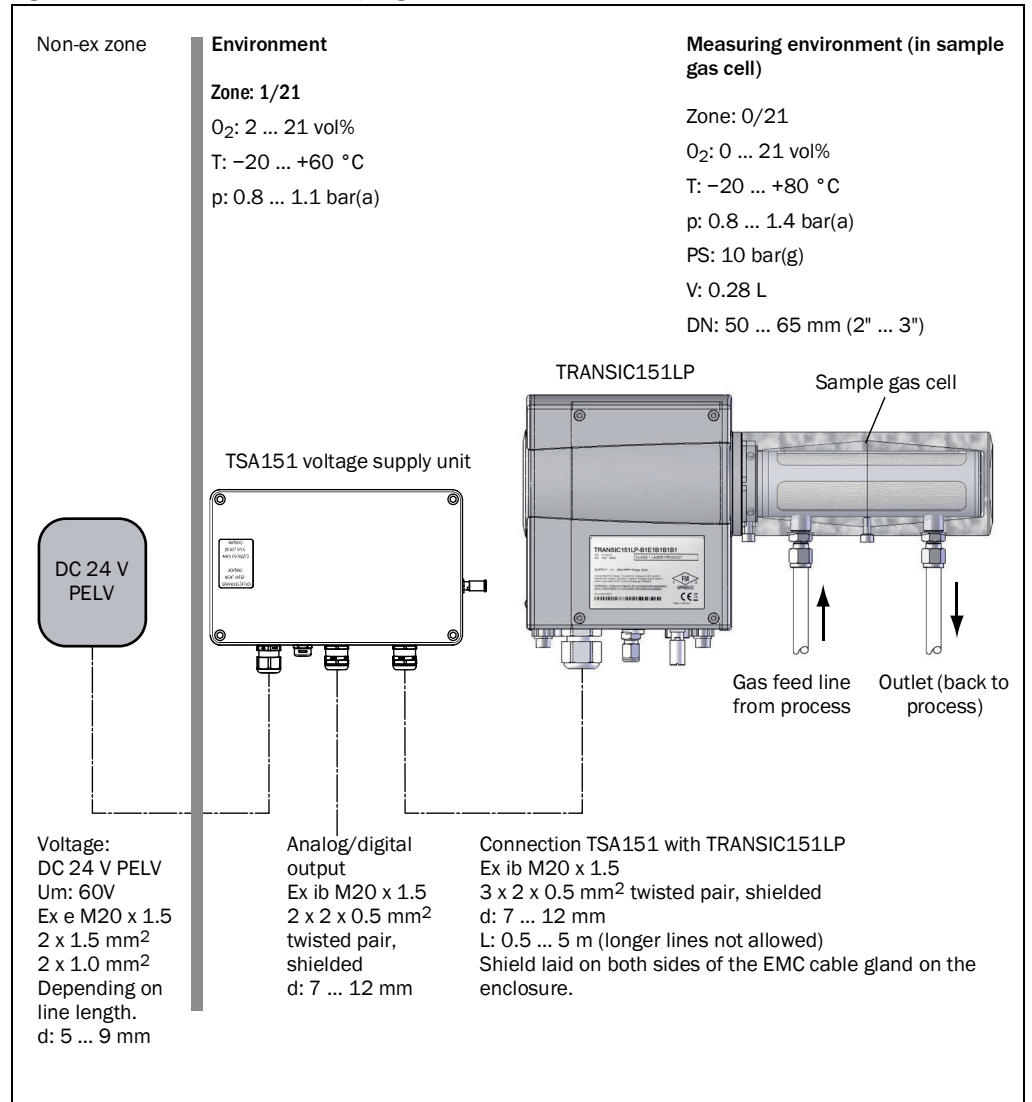

WARNING: Ex certification becomes void for unallowed wiring
 ► Comply with wiring requirements, see "Connections", page 25.

2.3.3 Variant for ambient gas measurement

Fig. 4: TRANSIC151LP-B for ambient gas measurement and wall bracket

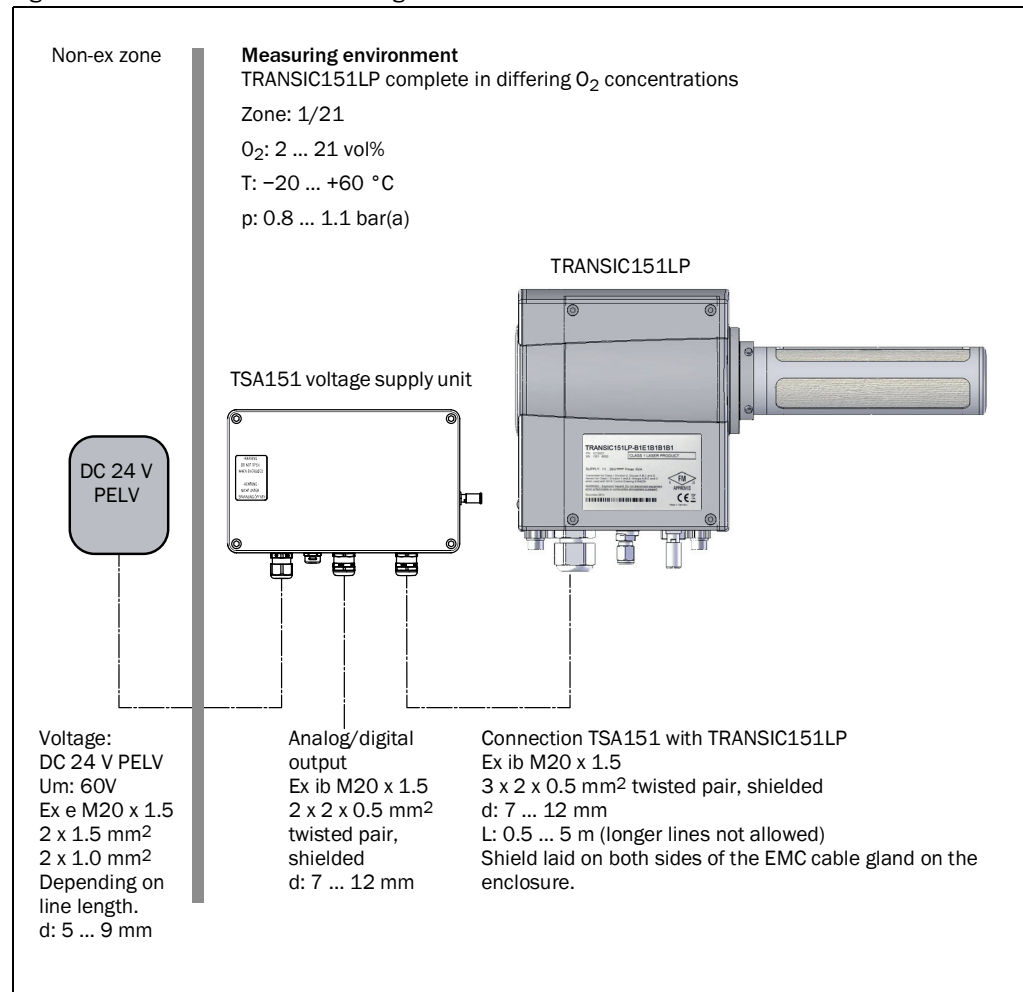

When configuring ambient gas measurements, the complete TRANSIC151LP must be exposed to the O₂ concentration to be measured because the transmitter is part of the O₂ measurement.

The TRANSIC151LP variant for ambient measurements measures oxygen concentrations from 2 ... 21 vol% O₂.

The measuring function is lost for oxygen concentrations under 2 vol%.



WARNING: Ex certification becomes void for unallowed wiring

► Comply with wiring requirements, see [“Connections”, page 25](#).

2.4 Explosion protection according to ATEX and IECEx



Transmitter:

- Transmitter
 - Gas
 - outside the process: II 2G Ex ib IIB T4 Gb
 - within the process: II 1G Ex op is IIB T4 Ga
 - Dust (*alternative*)
 - outside/within the process: II 2D Ex ib tb op is IIIC T85 °C Db
- TSA151 voltage supply unit
 - Gas: II 2G Ex eb mb [ib] IIB T4 Gb
 - Dust (*alternative*): II 2D Ex tb [ib] IIIC Db
- The Ex identification is on the type plate.
 Location of Ex relevant assemblies: see “Flange mounted TRANSIC151LP-A/-F/-G/-H”, page 12 and/or “TRANSIC151LP-C with sample gas cell and wall bracket”, page 13 “TRANSIC151LP-B for ambient gas measurement and wall bracket”, page 14.
 - ▶ Do not remove, add or change any components in or on the device unless such changes are officially allowed and specified by the manufacturer. Otherwise the approval for use in potentially explosive atmospheres becomes void.
 - ▶ Adhere to the prescribed maintenance intervals, see “Safety notes”, page 56.
 - ▶ The TRANSIC151LP may only be used in zones corresponding to the Ex identification (see type plate) of the transmitter and the power supply unit. Check the requirements of the installation location with the Ex certification of the device.
 - ▶ The TRANSIC151LP may only be installed by persons trained in the standards used (e.g., EN/IEC 60079-14).
 - ▶ The TRANSIC151LP may not be modified. Any modification to the device voids the Ex certification.

- The TRANSIC151LP is certified for a process-side operating range from 800 mbar(a) to 1400 mbar(a). Usage with deviating pressures voids the Ex certification.
- The TRANSIC151LP must be operated within the specifications described in the Section Technical Data, see “Technical Data”, page 67. Operating the TRANSIC151LP outside the specifications voids the Ex certification.

Operation in potentially explosive atmospheres

The TRANSIC151LP is suitable for the following zones

In accordance with ATEX (EN60079-10) and IECEx (IEC60079-10)

- Gas:
 - Measuring probe: Category 1G EPL Ga (Zone 0)
 - Transmitter / voltage supply unit: Category 2G EPL Gb (Zone 1)
- Dust (*alternative*):
 - Transmitter / voltage supply unit / measuring probe: Category 2D EPL Db (Zone 21)

The TRANSIC151LP may be used in zones in which either inflammable or explosive gases in groups I, IIA and IIB or inflammable dust in groups IIIA, IIIB and IIIC are present.

Temperature class: Gas: T4 (max. surface temperature 135 °C); dust: T85 °C

**CAUTION:** Observe marking for special operating conditions

Special operating conditions: Marking "X" on the TRANSIC151LP type plate means the wall thickness of the temperature probe is $0.2 < d < 1$ mm. In order to maintain the zone separation, the temperature probe may not be exposed to corrosive atmospheres that can endanger zone separation.

- ▶ Check the condition of the temperature probe (e.g., for corrosion) during every regular maintenance.

**CAUTION:** Observe marking for special operating conditions

Special operating conditions: Marking "X" on the TSA151 type plate means a PELV power supply unit is mandatory for voltage supply to the TSA151.

- ▶ See also Section "[Special local conditions](#)", page 10.
 - ▶ TSA151 Power Supply: Protective Extra Low Voltage (PELV) power supply is required. The 24V inlet of the TSA151 is specified with a fault voltage of $U_m=60V$.
-

3 Installation

3.1 Project planning

3.1.1 Chemical tolerance

The TRANSIC151LP contains several seals. Two material options are available for the seals:

- FKM (fluoro elastomer)
- Kalrez® Spectrum 6375 (perfluor elastomer)



NOTE: Specify suitable seals when ordering

- ▶ Changing the seals later is work intensive and can only be done by Endress+Hauser.



WARNING: Hazard through incorrect sealing material
Incorrect sealing material can revoke zone separation.



WARNING: Toxic gases escaping
Incorrect sealing material leads to leaks.

- ▶ Ensure the seal used is compatible with the temperature of the process gas in your application.

3.1.2 Temperature conditions

The TRANSIC151LP probe contains a temperature probe. This measures the sample gas temperature. Changes are compensated metrologically.

Observe the temperature conditions in the different variants, [see “TRANSIC151LP variants”, page 12](#).

The temperature probe and the enclosure are connected heat-conductive. Thus, the ambient temperature affects the measured value of the temperature probe. This causes measurement errors because the measured temperature value used in compensation deviates slightly from the actual process gas temperature. Avoid heat build-up through direct sunlight: Use the optional weather hood when appropriate, ([see “Spare parts and accessories”, page 61](#)).

Further information on the operating temperature range of the measuring device, [see “Ambient conditions”, page 73](#).



NOTE: The temperature gradient between process and surroundings influences the measured value.

- ▶ The ambient temperature of the measuring device enclosure at the installation location should correspond to the process temperature.

3.1.3 Strong light sources near the oxygen measuring probe



NOTE: Strong light sources interfere with TRANSIC151LP operation

- ▶ Prevent strong light sources reaching the measuring probe.

The interfering effect is influenced by:

- Filter used
- Light incidence angle into the measuring probe
- ▶ Use a stainless steel mesh filter for ambient light, e.g., normal interior or laboratory light.
- ▶ Use a PTFE filter for especially strong light sources, e.g., outdoors with direct sunlight.

3.1.4 Pressure

Observe the specifications on pressure conditions, [see “Flange mounted TRANSIC151LP-A/-F/-G/-H”, page 12](#), [“TRANSIC151LP-C with sample gas cell and wall bracket”, page 13](#) and [“Pressure suitability”, page 77](#).

3.2 Information on installation in potentially explosive atmospheres



When using the device in potentially explosive atmospheres:

- ▶ Installation, start-up, maintenance and inspection should only be performed by experienced technicians with knowledge of the relevant rules and regulations for potentially explosive atmospheres.



WARNING: Ex certification becomes void for unallowed power supply

- ▶ Only use the TSA151 voltage supply unit to run the TRANSIC151LP.
- ▶ Only use a 24V DC PELV power supply unit on the TSA151 voltage supply unit.
- ▶ Observe the "X" marking on the type plate, see "Type code TRANSIC151LP", page 80.

3.3 Installation

3.3.1 Safety information



WARNING: Toxic gases escaping

- ▶ Ensure the seals have been fitted and the installation is gas-tight.



WARNING: Acids and alkalis escaping

- ▶ Ensure the installation is completely sealed.



Installation information: Only use Endress+Hauser original accessories and spare parts, see "Spare parts and accessories", page 61.



WARNING: Risk of injury through device components under pressure

- ▶ Only install and remove the TRANSIC151LP when free from pressure.



When necessary, provide separating elements to ensure safe installation and removal.



WARNING: Risk of injury through components unsuitable for pressure

- ▶ Only use components designed for the process pressure in the application.



WARNING: Start-up only by technicians

The TRANSIC151LP may be installed and put into operation only by technicians with appropriate training, who, based on their training and knowledge of relevant regulations concerning the gases used can assess and detect hazards.



NOTE: Check the TRANSIC151LP for completeness and damage

Check the TRANSIC151LP for completeness and damage (e.g., through transport) before start-up.

3.3.2 Prerequisites for assembly

An effective gas exchange is required in the optical path to ensure adequate response times and avoid condensation.

Place the TRANSIC151LP probe as far as possible in the process. The recommended minimum depth is 5 cm.

In case of an axial installation in a tube or flange piece, the tube diameter must be wide enough to allow gas exchange. Here, the recommended diameter is minimum 60 mm.

The dewpoint can be underflown when the probe is only inserted a little into the process or the temperature difference between environment and process is too high ($>30\text{ }^{\circ}\text{C}$). In these cases, the flange area must be insulated or heated.

3.3.3 Installation angle

Install the TRANSIC151LP at a self-draining angle. When the process is very wet, ensure no liquid can reach the beam path.

- Installation angle, see “Installation angle in high humidity”, page 19.
- The probe can be tilted freely when the process gas is dry (the process temperature is much higher than the dew point of the gas) so that there is no risk of condensation.
- When using the sample gas cell: It is possible that measured values for high O_2 concentrations can depend on the flow rate when the probe and sample gas cell are installed in vertical direction.
 - ▶ Do not install the measuring probe vertical.

Fig. 5: Installation angle in high humidity

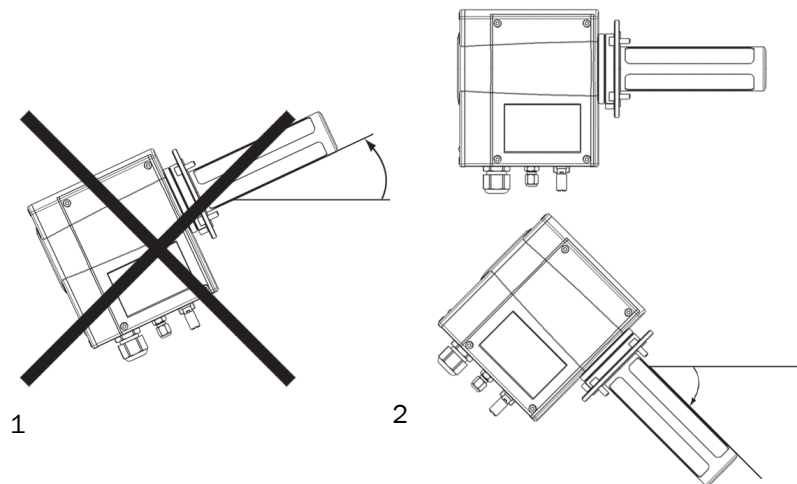

- 1 = The probe must not point upwards when there is a risk of condensation.
- 2 = Install the probe aligned horizontally or at a maximum downward angle of 45 ° in high humidity (5 ° downwards is recommended).

3.4 Installation options

3.4.1 Process conditions for installation options

The basic TRANSIC151LP variant provides the following installation options:

- 1 In-situ measurement (flange installation)
- 2 Extractive measurement (installation with sample gas cell)

Information on process conditions for the various installation options can be found in the Technical Data Section, see [“Ambient conditions”, page 73.](#)



NOTE: Installation of the TRANSIC151LP special variant for ambient gas measurement, see [“TRANSIC151LP installation - ambient gas measurements”, page 24.](#)

3.4.2 TRANSIC151LP installation - in-situ with flange

Filter recommendation

- Stainless steel mesh filter: Protection against coarse dirt and incident light
- PTFE filter: Reduces the effects on oxygen measurements resulting from water, dust, other contamination and extremely strong ambient light. Gases and vapors are not filtered.



NOTE: Filters influence the response time

- For short response times: Remove the filter.
The optical components are then more susceptible to contamination and must therefore be cleaned more often, see [“Safety notes”, page 56.](#)
Do not remove the filter when humidity or dirt can reach the optical components. Read [“Strong light sources near the oxygen measuring probe”, page 17](#) before taking the filter out.
- Do not use a PTFE filter for measurements near the dew point.
- Short reaction times not required: Endress+Hauser recommends using PTFE filters and stainless steel mesh filters.

Fig. 6: TRANSIC151LP with flange adapter

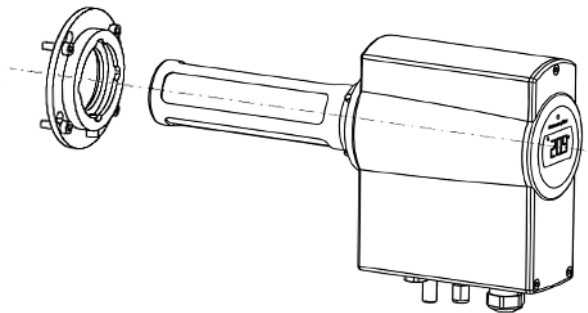

Suitable process flanges

Information on the diameter of the TRANSIC151LP flange adapter and flanges can be found in the Data Table [“Pressure suitability”, page 77.](#)

The smallest DIN flange suited for the flange adapter of TRANSIC151LP is a DIN/ISO 1092 DN50 flange (fitted with M16 hex bolts). All the flange adapters are fitted at the factory and are fastened to the probe with a screw, see [“Type code TRANSIC151LP”, page 80.](#)

Installation with clamping flange

A suitable counterflange must be present on the plant side in order to install the TRANSIC151LP with clamping flange 3"/ DN65 in accordance with DIN 32767. The scope of delivery does not include a seal. The customer must select the seal. The pressure, the chemical and thermal requirements must be considered when selecting the seal. Dimension drawing, see ["Adapter flange, clamping flange DIN32676 3"/DN65, suitable for PS= 10 bar\(g\)", page 69.](#)

Installation with welding adapter

The welding adapter must be welded on in accordance with valid, regional regulations.



WARNING: Risk of toxic gases escaping

► Carry out a leakage test after installation to exclude the risk of process gas escaping.

Installation with flange adapter:

- 1 Drill the threads in the process flange. Flange adapter dimensions and drilling instructions, see ["Mounting flange with M5 bolts suitable up to 0.5 bar\(g\)", page 68](#) and ["Mounting flange with M8 bolts suitable for PS=10 bar \(g\)", page 68.](#)
- 2 Flange adapter with M5 screws:
 - a) Screw the four M5 flange adapter fastening screws provided more or less halfway into the prepared threads.
 - b) Push the TRANSIC151LP through the process flange. Check the correct position of the flange adapter seal to ensure a gas-tight connection between flange adapter and process flange.
 - c) Turn the TRANSIC151LP clockwise so that the screws fit through the larger recesses of the flange adapter. Then turn the TRANSIC151LP counterclockwise to the stop.
- 3 Flange adapter with M8 screws:
 - d) Push the TRANSIC151LP through the process flange.
 - e) Check the correct position of the flange adapter seal to ensure a gas-tight connection between flange adapter and process flange.
 - a) Screw the four M8 fastening screws provided for the flange adapter in the threads.
 - b) Tighten the screws to finish installation.



The TRANSIC151LP can be removed from the process by loosening the screws holding the flange adapter in place. However, this is not recommended because fitting the TRANSIC151LP measuring device back on again is difficult.

3.4.3 TRANSIC151LP installation - extractive

Filter recommendation



CAUTION: Risk of burns through hot gases

- ▶ Attach the enclosed warning label to the sample gas cell surface when process temperatures are >65 °C.

- Stainless steel mesh filter: Minimum protection against dirt particles.
- PTFE filter: For gas with humidity and/or fine dirt particles.



NOTE: Preparing the gas sample for dirty and wet gas

- ▶ Filter and dry the gas sample before pumping it into the sample gas cell.
- ▶ Use a hydrophobic dust filter before the inlet opening of the sample gas cell to protect the optical components against particle and water.
- ▶ Replace the dust filter regularly to ensure sufficient throughflow.
- ▶ Dry the gas through cooling and reheating to guard against condensation in the sample gas cell.

Fig. 7: TRANSIC151LP with sample gas cell

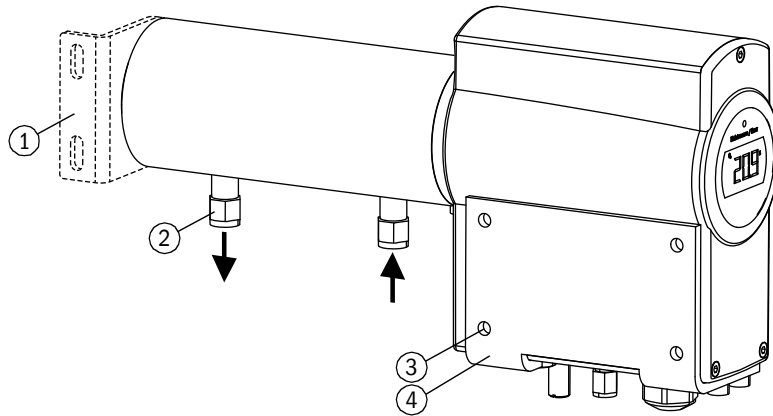

- 1 = Optionally available assembly bracket
- 2 = Swagelok connections for Ø 6 mm gas tubes
- 3 = Max. screw size M6
- 4 = Wall bracket

Installing the wall bracket

- 1 Fasten the wall bracket
Wall bracket dimensions, see [“TRANSIC151LP with wall bracket and sample gas cell \(suitable for PS=10 bar\(g\)\)”](#), page 70.
- 2 Fasten the TRANSIC151LP
 - 1 Install the TRANSIC151LP on the wall bracket using the four M6 screws provided.
 - 2 First fix both outer screws in the threads at the bottom of the TRANSIC151LP. This simplifies fastening the two inner screws when positioning the TRANSIC151LP on the wall bracket.
 - 3 Tighten all four screws.

Installing the sample gas line

- 1 Provide adequate support for the tubing, for example by attaching it to the wall. The tube must not put any traction on the connection.
- 2 The sample gas cell has two gas connections. Use the gas connection closest to the TRANSIC151LP as gas inlet. This provides a better gas exchange and shorter response times.

Installing the sample gas cell

Dimensions of the TRANSIC151LP with sample gas cell, see [“TRANSIC151LP with wall bracket and sample gas cell \(suitable for PS=10 bar\(g\)\)”, page 70.](#)

When a TRANSIC151LP with sample gas cell is ordered, it is delivered with the cell fixed at the factory and prepared for wall fitting.

- ▶ Take the sample gas cell off to check and replace the filter.
 - 1 Loosen the bayonet tube screw fitting, see [“Removing the sample gas cell”, page 23,](#) turn the sample gas cell and then pull it off the TRANSIC151LP, see [“Removing the sample gas cell”, page 23.](#)
 - 2 Refit the bayonet screw fitting in the reverse sequence. Ensure the seal is located between the sample gas cell and measuring device enclosure. The Swagelok connections must point directly downwards.

Fig. 8: Removing the sample gas cell

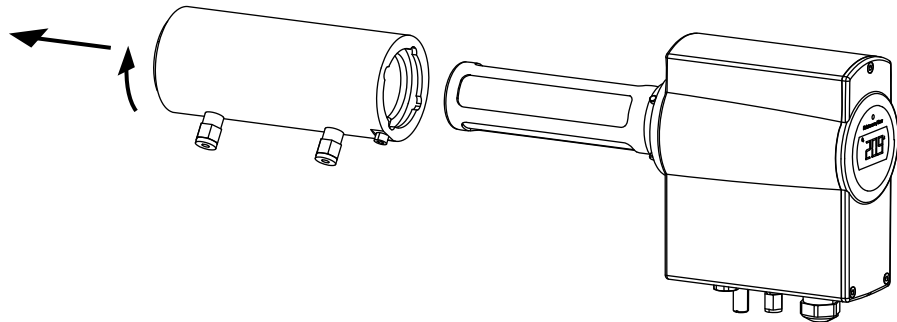

3.4.4 TRANSIC151LP installation - ambient gas measurements

Installation Instructions

Fig. 9: TRANSIC151LP, fitted on a wall

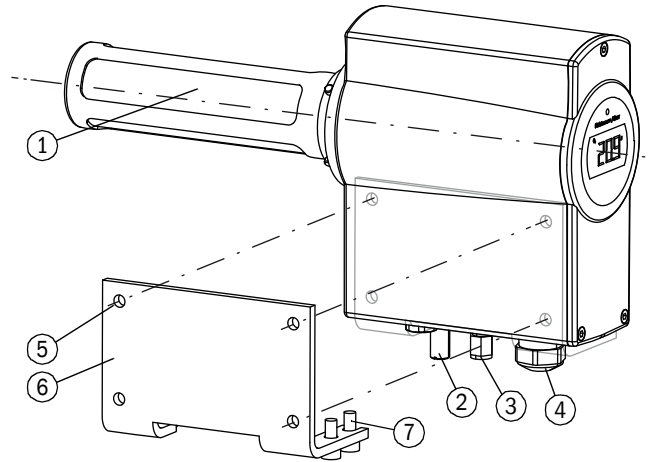

- 1 = Stainless steel mesh filter
- 2 = External grounding connection
- 3 = Calibration gas inlet with a \varnothing 6 mm Swagelok connection (optional)
- 4 = M20 \times 1.5 cable gland for supply and signal lines
- 5 = Max. screw size M6
- 6 = Wall bracket
- 7 = Device screws

- 1 Fit the wall bracket to the 4 drill holes.
- 2 Fasten the TRANSIC151LP to the wall with the four M6 screws.



First fix both outer screws in the threads at the bottom of the TRANSIC151LP. This simplifies fastening the two inner screws when positioning the TRANSIC151LP on the wall bracket.

- 3 Tighten the four screws.



Dimensions and drill holes for the wall bracket, see "Wall bracket", page 67.



Ensure the TRANSIC151LP is installed in a representative gas mixture.

3.5 Connections

Fig. 10: Connections

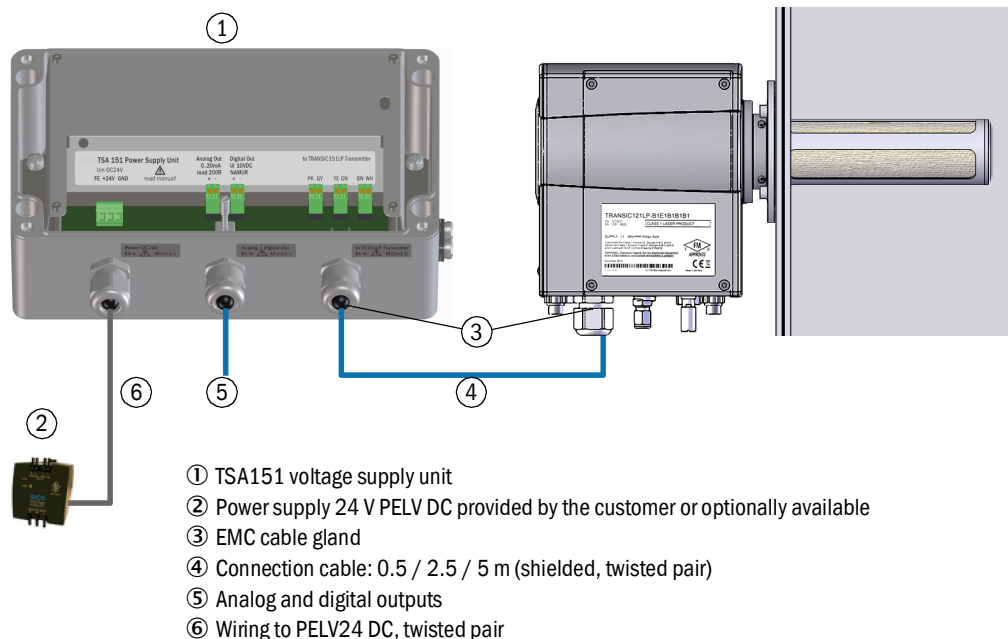

Connections and shielding

- 
WARNING: Unallowed voltage supply voids the Ex certification
 Only connect the TRANSIC151LP via the TSA151 voltage supply unit.
 Only use a 24V DC PELV power supply unit on the TSA151 voltage supply unit.
 ▶ Observe the “X” marking on the type plate, see “Product identification”, page 11

- 
WARNING: Using unallowed cables voids the Ex certification
 If the cables are not Endress+Hauser standard cables, they must meet the cable specifications in Table “TSA151 safety-related technical characteristic data (IECEx/ATEX)”, page 75.

- 
WARNING: Damage to cabling through heat
 ▶ Only use cables specified for temperatures >70 °C.

- 
NOTE: Risk of damage to the TSA151 through dust or humidity
 ▶ Only open the TSA151 in a dry environment free from dust.

Connection cable shield

- 1 Mark the lines (4 and 5) as intrinsically safe.
- 2 Connect the shield from (4) to both sides of the EMC cable gland (3).
- 3 Cable shielding for analog and digital output (5):
 - Option 1: Connect the shield as capacitive:
 - ▶ Connect the cable shield to the shielding terminal in the enclosure.
 - Option 2: Connect the shield to the enclosure:
 - ▶ Connect the cable shield to the cable gland

Grounding the transmitter and voltage supply

Ground both the transmitter and the voltage supply unit. Use conductors suitable for grounding. Connect both enclosures to the local ground. Lay the grounding as functional grounding. There must be no potential differences between both enclosures.

The TRANSIC151LP is delivered already connected to the TSA151 voltage supply unit with a supply cable as standard. Endress+Hauser delivers the following cable lengths depending on the customer order: 0.5 m, 2 m or 5 m. (Maximum cable length 5 m).

Other cables can also be used. These must meet the specifications in the Technical Data, see [“TSA151 safety-related technical characteristic data \(IECEX/ATEX\)”](#), page 75.



WARNING: Ex certification becomes void

Enclosure degree of protection IP66 must *not* be degraded by using conduit cabling.

- ▶ Use a strain relief.
 - ▶ Observe regional standards and regulations.
-

3.5.1 Connecting the TRANSIC151LP transmitter

Fig. 11: TRANSIC151LP - electrical connections



- ① Maintenance interface (Endress+Hauser Service Adapter required)
- ② LED lamp
- ③ Keypad
- ④ Voltage supply
- ⑤ Analog output
- ⑥ Digital output (NAMUR)

Replacing the TRANSIC151LP cable

- 1 Ensure the device is disconnected from the mains and potential-free.
- 2 Remove the cover on the front side of the TRANSIC151LP.
- 3 Push the cable through the cable gland. (Max. cable length: 5 m).
- 4 Connect to voltage supply terminals U-in(4)PK (pink) and GY (gray).
- 5 Connect to analog output I-out (5) YE (yellow) and GN (green).
- 6 Connect to digital output D-out (6) BN (brown) and WH (white). A NAMUR digital output is located between terminals BN and WH, [see "Pressure suitability", page 77](#).
- 7 Connect the shielding to the cable gland.
- 8 Close the cable gland. Tightening torque: 10 Nm
- 9 Ensure the cable gland seals the cable.
- 10 Close the device front panel.
- 11 Ensure the enclosure is closed tight.



Cable colors are oriented to DIN47100.

3.5.2 Connecting the TSA151 voltage supply unit



CAUTION: Risk of injury through electric voltage

- ▶ Never open the TSA151 when voltage is applied.



NOTE: Risk of damage to the TSA151 through dust or humidity

- ▶ Only open the TSA151 in a dry environment free from dust.

The TRANSIC151LP is delivered with the TSA151 voltage supply unit already fitted.
The TSA151 supplies the TRANSIC151LP with an intrinsically safe (ib) power circuit.

Fig. 12: TSA151 voltage supply unit connections

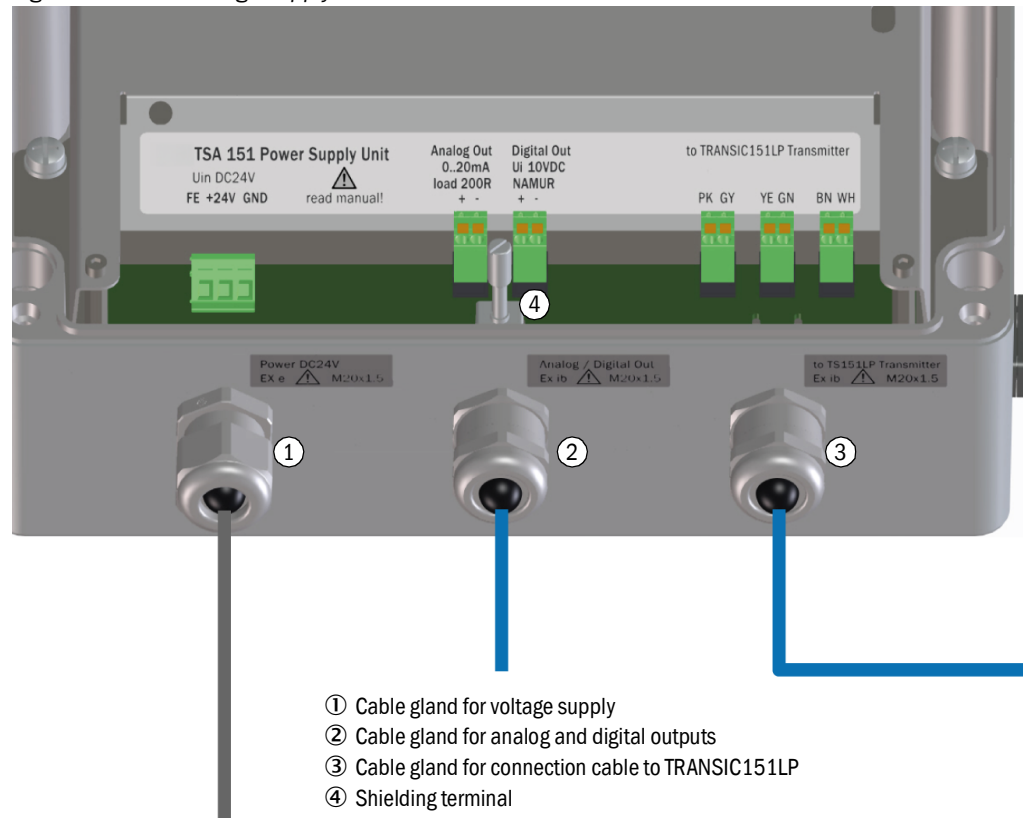

Replacing the connection cable:

- 1 Ensure the voltage is switched off.
- 2 Remove the cover of the TSA151 voltage supply unit.
- 3 Push the cable through cable gland (3). (Max. cable length: 5 m).
- 4 Connect voltage supply terminals PK (pink) and GY (gray).
- 5 Connect the analog output YE (yellow) and GN (green).
- 6 Connect the digital output BN (brown) and WH (white). A NAMUR contact is located between the terminals BN (brown) and WH (white).
- 7 Connect the shielding to the cable gland.
- 8 Close the cable gland. Tightening torque: 10 Nm
- 9 Ensure the cable gland seals the cable.
- 10 Connect analog output I out of the TSA151 voltage supply unit.

3.5.3 Connecting the analog and digital outputs

In the non-ex zone, the analog output must be connected using an Ex separation stage with a maximum sense resistance of 200 Ohm (e.g., Endress+Hauser 6051123).

The digital output is implemented as a NAMUR contact. This must be connected in the Ex-free zone using a NAMUR switching amplifier (e.g., Endress+Hauser 6051124).



Observe the specifications in the Technical Data, [Page 74](#).

- 1 Ensure the voltage is switched off.
- 2 Remove the cover of the TSA151 voltage supply unit.
- 3 Push the cable through cable gland (2).
- 4 Connect analog output Analog out + and –.
- 5 Connect digital output Digital out + and –.
- 6 Connect the shielding to shielding terminal (4).
- 7 Close the cable gland. Tightening torque: 10 Nm.
- 8 Ensure the cable gland seals the cable.
- 9 Connect digital output D-out of the TSA151 voltage supply unit.

3.5.4 Connecting power supply to the TSA151 voltage supply unit



CAUTION: Electrical voltages!

- ▶ Always ensure the lines are disconnected before starting any electrical work.



A 24 PELV power supply unit is mandatory for the supply to guarantee an Um fault voltage of 60 V.
Endress+Hauser Part No. 6042607 or 6034520 (for use in zone 2).

- Supply voltage, as in the Technical Data, [Page 75](#).
- 1 Ensure the voltage is switched off.
 - 2 Remove the cover of the TSA151 voltage supply unit.
 - 3 Push the cable through cable gland (1).
 - 4 Connect the supply voltage to terminals +24V and GND.
Terminal FE serves optional internal connection of the functional ground.
 - 5 Close the cable gland. Tightening torque: 3 Nm.
 - 6 Ensure the cable gland seals the cable.



The 24V PELV power supply unit must have an overvoltage protection device.



In order to switch the TSA151 disconnected from the mains and potential-free, a disconnecting device must be planned in the non-ex zone before the PELV power supply unit. Fit the disconnecting device as close as possible to the measuring device and easily accessible.

3.5.5 Gas connection (optional)

The optional test gas inlet is specified when ordering.

Fig. 13: Test gas inlet (optional)

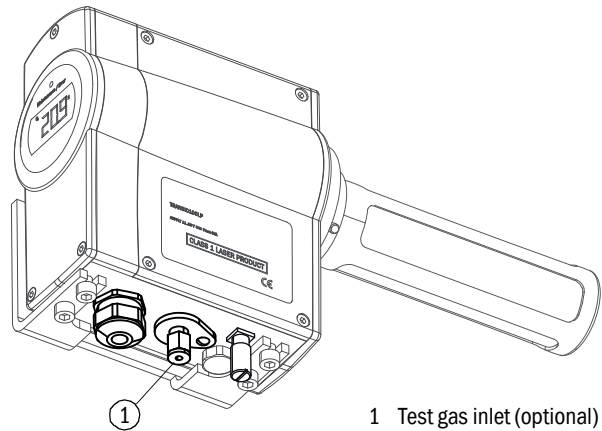

The test gas inlet has a 6 mm Swagelok for tube or hose.

► Observe the suitability for:

- Pressure
- Gases
- Temperatures
- Oxygen

The test gas connection has a non-return valve with opening pressure of 1.7 bar (see [“Connections and systems”, page 45](#)).

4 Operation

4.1 Safety instructions for operation



NOTE: Risk of damage to the TSA151 through dust or humidity

- ▶ Only open the TSA151 in a dry environment free from dust.



NOTE: Read the instructions through carefully before making any settings or parameter changes. Endress+Hauser accepts no responsibility for parameter or setting changes nor adjustments made by the user. Contact Endress+Hauser Customer Service when you require technical support.



The password can be found in the Annex, [see "Password", page 81.](#)



DANGER: Hazard through incorrect parameter settings

Incorrect settings for parameters can have severe consequences. This is why the password may only be available for authorized technicians.

- ▶ Note the password in the Manual and keep it safe somewhere else, [see "Password", page 81.](#)

4.2 Interfaces

There are 2 control interfaces

- Keypad (on the front TRANSIC151LP panel)
- Maintenance interface



Changes to parameters are password protected. The password allows access for 30 minutes after entry.

4.2.1 Control via keypad

A display and four pushbuttons are located on the front enclosure panel. The measured oxygen value is shown on the display. LEDs signal the operating mode of the measuring device. A green LED indicates normal operation.

Characteristics

The main purpose of the integrated interface (keypad/display) is field calibration.

The following values can be set to attain higher measurement precision:

- Process pressure
- Humidity
- Carbon dioxide content

Fig. 14: Display and keypad

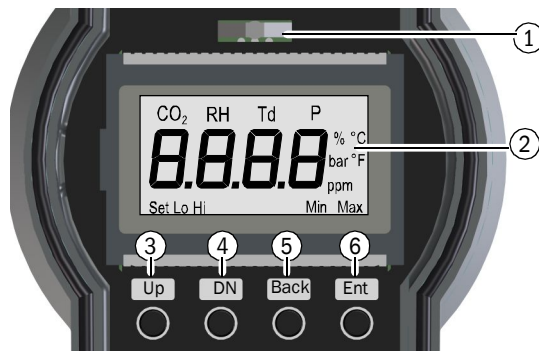

- 1 LED (red/yellow/green)
- 2 Seven-part display
- 3 Up - Upwards button
- 4 Dn - Downwards button
- 5 Back - Back button
- 6 Ent - Input button

Display modes

The display is in one of the following modes when no input is made:

Display modes	Display / LED	Process
Start (duration: 2.5 minutes)	Software version Self-test PASS	Self-test starts Information: Self-test running Warming up phase starts.
Normal operation	Green LED remains on Measured oxygen value	Measured oxygen value is shown continuously.
Error state	Red LED remains on Error state number	
Warning	Yellow LED blinks Measured oxygen value is displayed	Select function <i>Err</i> in the menu or Error Table, see page 63 .

Table 1: Display modes

4.2.2 Maintenance interface

The maintenance interface is located on the connector block above the display. It serves:

- Maintenance
- Calibration
- Changing parameters.

All adjustable parameters can be accessed with a PC terminal program (e.g., Hyperterminal) via the serial maintenance interface.

A special interface cable serves to connect the TRANSIC151LP and the PC.

The maintenance interface provides more configuration options for alarm threshold(s) or other settings than the keypad and display.

4.2.3 Analog output

The TRANSIC151LP has a non-insulated current output. The configuration of the active analog output (0 or 4 ... 20 mA) and the switching behavior in an error state are determined at order time. These parameters can be changed via the maintenance interface.

4.2.4 NAMUR digital output

The NAMUR digital output can be configured at order time so that it signals limit value overflows or underflows, warnings or device errors. These settings can be changed via the maintenance interface.

4.3 Settings using the keypad

4.3.1 Short description: Input of settings using the keypad

- ▶ Buttons *Up* or *Dn* serve to open and scroll through the menu.
- ▶ Button *Enter* activates the functions.
- ▶ Button *Back* cancels a process.
- ▶ Use the *Up/Dn* buttons to enter numeric values when no other method is specified:
 - Press *Up* to increment a digit by one.
 - Press *Dn* to toggle through the digits in the display.



The menu items are shown in the following Sections “Menu navigation without password authorization” and “Menu navigation with password authorization” in the same sequence as in the menu navigation.

Fig. 15: Blinking display

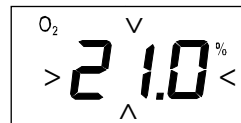

4.3.2 Safety information on using the password:



DANGER: Serious consequences when parameters are changed without authorization

Unauthorized changing of parameters can have severe consequences. This is why the password is only available for authorized technicians.

4.4 Menu navigation without password

Values can only be read and reset in this part of menu navigation.

This part ends when the password is entered. Menu navigation starts from the top again after the password is entered.

4.4.1 Oxygen statistics (O₂)

This menu item displays the minimum and maximum oxygen values measured since the last reset. The statistics can also be restarted with the current value.

Fig. 16: Displaying and resetting the oxygen statistics

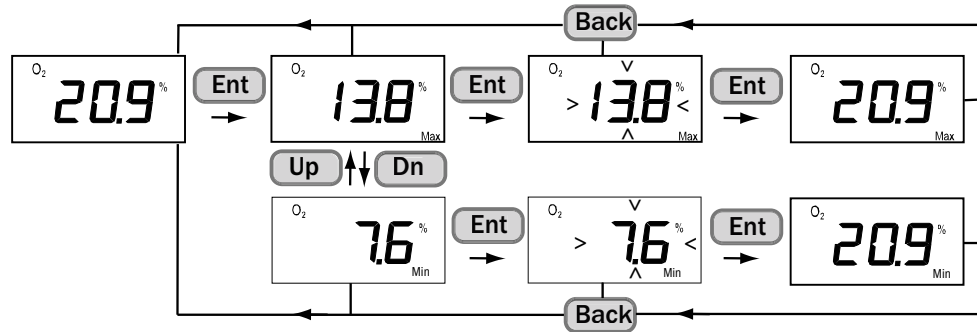

4.4.2 Temperature statistics (T)

This menu item displays the minimum and maximum temperature values measured since the last reset. The statistics can also be restarted with the current value.

Fig. 17: Displaying and resetting the temperature statistics

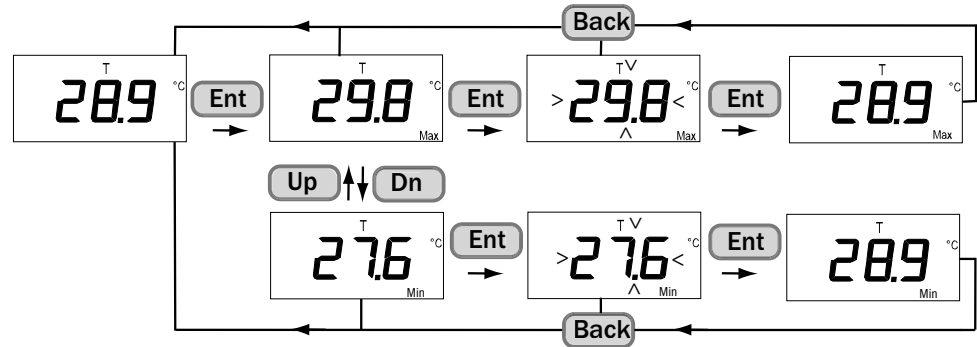

4.4.3 Calibration gas, actual value (CAL.C)

- 1 Freezes the analog output.
- 2 Displays the current O₂ concentration measured.

Fig. 18: Calibration gas, actual value display

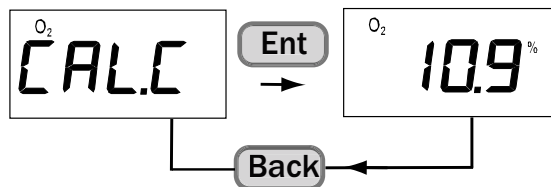

4.4.4 Signal intensity(SIL)

- 1 Compares the current signal intensity of the laser on the receiver against the signal intensity from the factory calibration.
- 2 The signal intensity serves to determine contamination on the optics. Important: The laser signal can be amplified so that values above 100% are possible.

Fig. 19: Signal intensity display

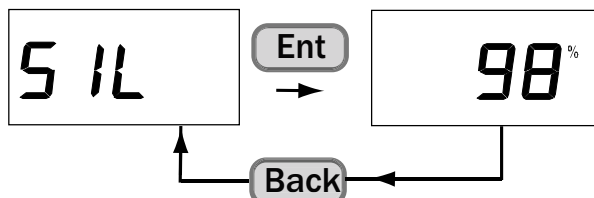

Information on alarm thresholds, see “TRANSIC151LP behavior when errors occur”, page 62.

4.4.5 Display of active and undeleted errors (ERR)

This menu displays all active error messages. Fig. 20 describes how the errors are read out and deleted. The display shows E 0 when all errors have been deleted. Significance of error numbers, see “Error Table”, page 63.

Fig. 20: Displaying all errors currently existing

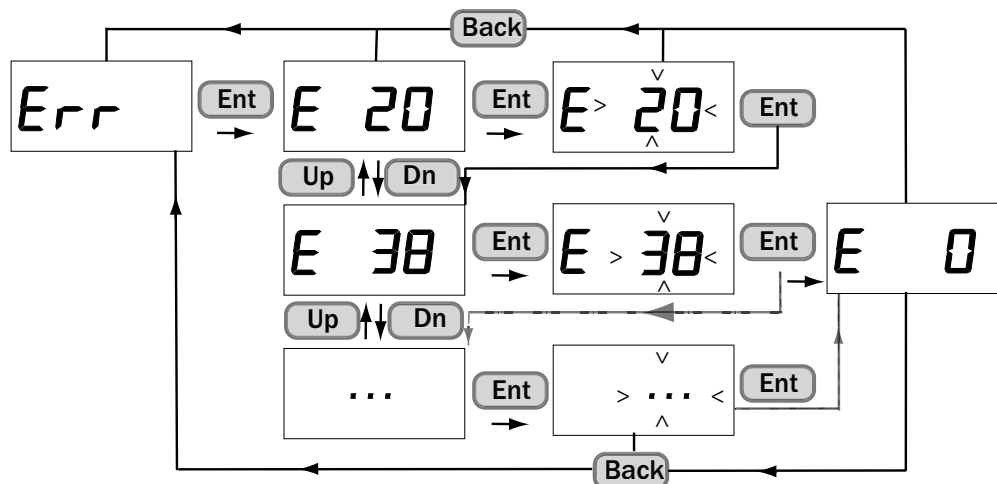

4.4.6 Entering the password (PAS)

- 1 Entering the password makes additional menu items available.
- 2 These additional menu items remain accessible for 30 minutes.
- 3 Observe the safety instructions, see “Safety information on using the password:”, page 33.

+i Menu navigation starts from the top again after the password is entered (Measured value display).

Fig. 21: Entering the password

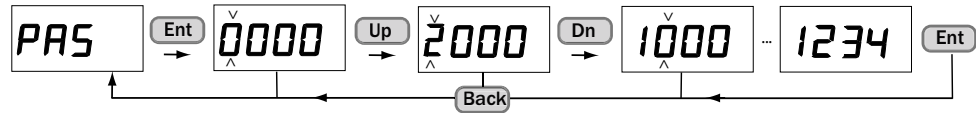

4.5 Menu navigation with password authorization

The maintenance level is open for all interfaces after the password has been entered.



NOTE:

- After entering the password via the keypad, it is recommended to return to the oxygen statistics display after completing password protected functions.
- Even though the password expires in 30 minutes, maintenance functions remain available until you return to the basic functions in the menu structure. A message is not sent via the keypad when the password expires.

4.5.1 Process pressure: Display and settings (APP)

- 1 Enter the average pressure in the sample gas. Further information, see “Pressure compensation”, page 40.
Adjustable range: 800 ... 1400 mbar.

Fig. 22: Reading out and changing the process pressure

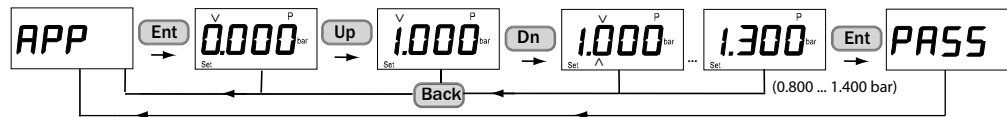

4.5.2 H₂O content in the process gas (H2O)

- 1 Enter the average H₂O value in the sample gas. Further information, see “Compensation of ambient parameters”, page 39.
Adjustable range: 0 ... 600 g/m³.

Fig. 23: Humidity in process gas setting

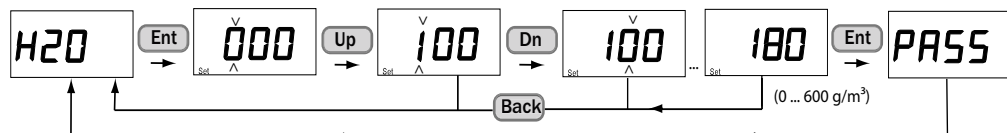

4.5.3 CO₂ content in process gas (CO2)

- 1 Enter the average CO₂ value in the sample gas.
Adjustable range: 0 ... 100% vol.

Fig. 24: CO₂ in sample gas setting

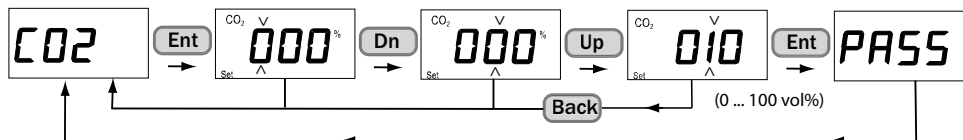

4.5.4 One-point calibration (CAL1)

Figure can be found in Section Adjustment, see [“One-point adjustment using the keypad”](#), page 50.

4.5.5 Two-point calibration (CAL2)

Figure can be found in Section Adjustment, see [“Two-point adjustment using the keypad”](#), page 51.

4.5.6 Analog output display and settings (AOU)

- 1 Press *Ent* to display the current output value on the analog output.
- 2 To set fixed output values for the active analog output (0, 4, 12, 20 mA), press *Ent* and use *Up* and *Dn* to select the analog output value.

Fig. 25: Displaying and setting the analog output value

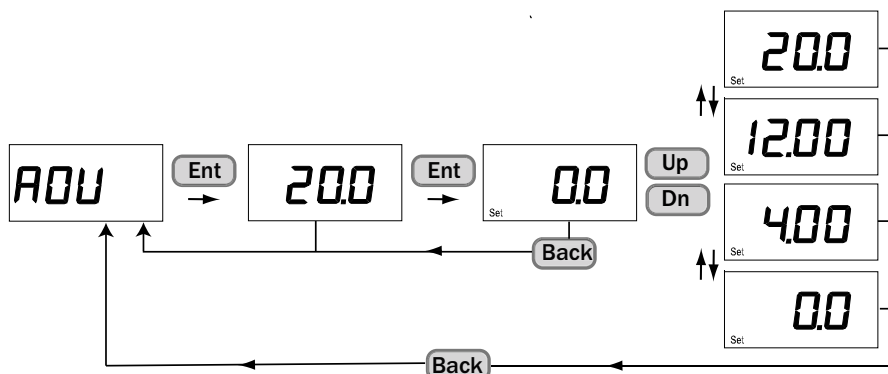

4.5.7 Resetting to the factory calibration (FAC)

The TRANSIC151LP is reset to the factory calibration.
(Gain value: 1, offset value: 0).

Fig. 26: Resetting to the factory setting for oxygen measurement

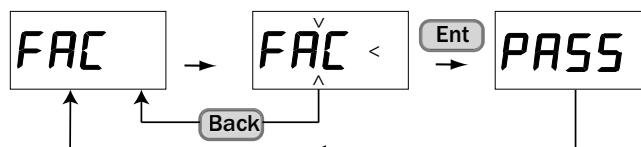

4.5.8 Scaling the analog output (ASCL)

The analog output can be scaled freely.

- 3 After pressing *Ent*, use submenu item *Set Lo* to set the oxygen value to be transferred with the lower mA value (4 mA or 0 mA).
- 4 Use submenu item *Set Hi* to set the oxygen value to be transferred with the upper mA value (20 mA).

Fig. 27: Scaling the analog output

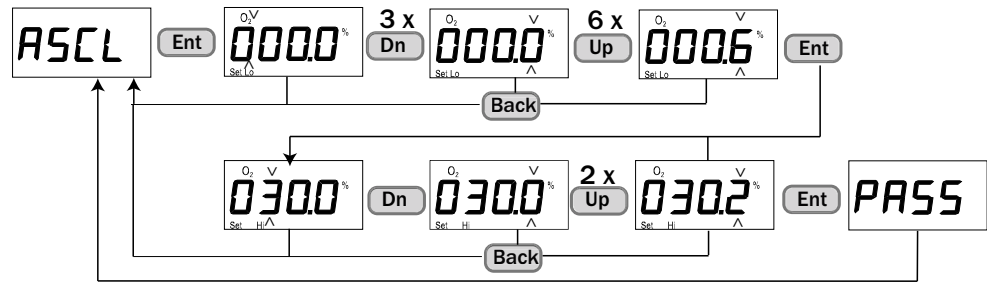

4.5.9 Digital output (ALA)

- 1 Press *Ent* to display the current switching position.
- 2 To check the switching function, press *Ent* and use *Dn* and *Up* to select the desired switching function *OPE* (open) or *CLO* (closed).

Fig. 28: Checking and changing the digital output state

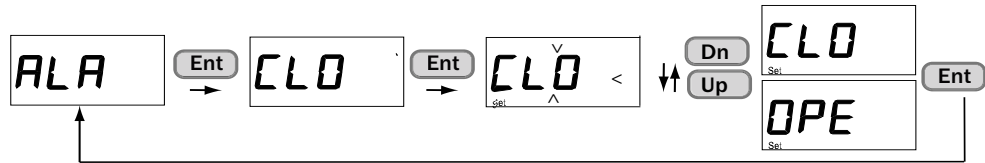

4.5.10 Resetting the measuring device (rESE)

TRANSIC151LP is restarted.

Fig. 29: Restart of the TRANSIC151LP oxygen sensor

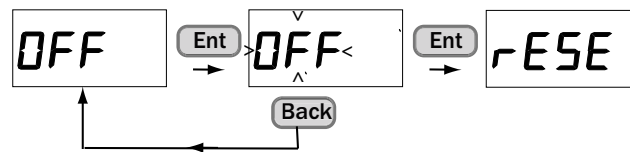

4.6 Maintenance interface

Observe the Operating Instructions delivered with the serial interface cable.

5 Setting ambient parameters

5.1 Compensation of ambient parameters

The TRANSIC151LP can compensate the temperature, pressure of the operating environment as well as water and CO₂ content of the background gas.

Ambient parameters	Standard	Activated	Remarks
Operating pressure (process pressure)	Standard ambient parameters: Pressure 1 bar(a)	Must be activated, ambient parameters must be set.	The pressure outside the process in which the measuring device enclosure is installed should be normal ambient air pressure. Further information, see "Variant for extractive measurement", page 13.
Humidity	Water content 0 g/m ³ H ₂ O, compensation deactivated		
CO ₂	Relative carbon dioxide concentration 0 vol % CO ₂		
Temperature	2 integrated temperature sensors: Inner temperature Process temperature	Automatic, always active	A significant difference between process gas temperature and the temperature in the measuring device enclosure can influence the measured value result.

Table 2: Compensation of ambient parameters

The typical effect of the error depending on the process pressure is shown in the non-compensated curve in Fig. 30. The error magnitude is smallest at normal ambient air pressure.

Fig. 30: Effect of process pressure compensation

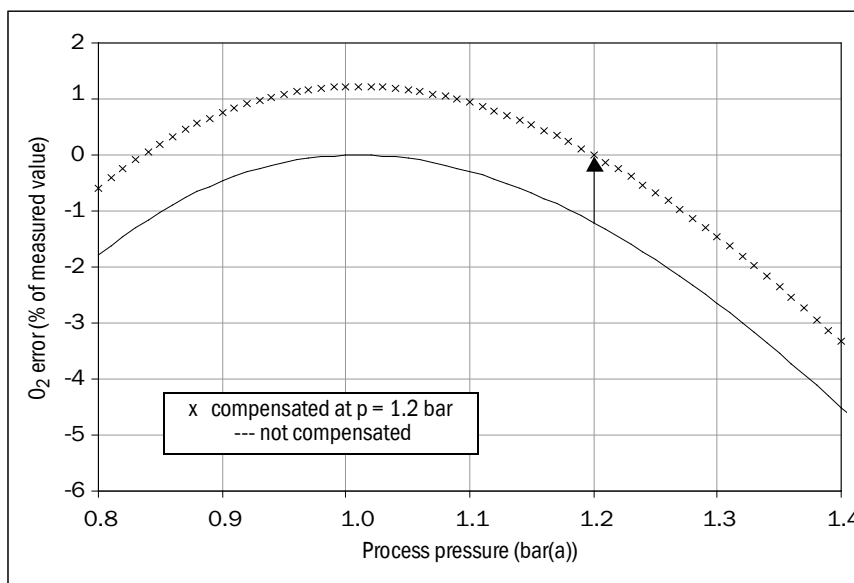

5.1.1 Pressure compensation

Setting the value of the average process pressure value compensates the measurement error more or less to zero in the immediate vicinity of the pressure value in question.

- ▶ Set the average pressure as parameter for the TRANSIC151LP. Keypad, see [“Process pressure: Display and settings \(APP\)”](#), page 36.

The graphic [“Effect of process pressure compensation”](#), page 39 illustrates the effect of pressure compensation when the average process pressure is set to 1.2 bar_a. The original error of approximately 1% of the measured value at 1.2 bar_a is compensated to zero. Pressure dependency remains for other values.

Pay particular attention that setting the pressure compensation does not shift the parabola-like curve shown in [“Effect of process pressure compensation”](#) along the X-axis. This means, even with compensation activated, pressure changes of the compensation value have a more significant effect than with 1.013 bar_a.



NOTE:

To disable pressure compensation, reset the average process pressure value to the standard ambient air pressure of 1.013 bar_a. The magnitude of pressure compensation is zero with this setting.



The allowable pressure range for compensation is 0.800 ... 1.400 bar_a.

5.1.2 Background gas effects

Individual absorption line widths of O₂ gas are sensitive to intermolecular collisions between O₂ and background gas molecules. This affects the measured O₂ values. The magnitude of this effect depends on the amount and type of background gas molecules. TRANSIC151LP factory calibration is carried out using dry N₂ and O₂ mixtures. Humidity and CO₂ concentrations of the calibration gases are 0%. Apart from dry N₂, all background gases result in a percentage measured value error for O₂ measurement.



All gases, apart from N₂, influence the measured value.

Contact Endress+Hauser Customer Service for information on the influence of further background gases.

Carbon dioxide and water vapor are the most common gases requiring compensation. Compensation for the average water and CO₂ contents of the background gas is integrated. The compensation is based on manual user settings for the values for the water and CO₂ content of the background gas in the device. The water content is expressed in terms of absolute humidity in g/m³ H₂O. Conversion Table, see [“Humidity Conversion Table”](#), page 78. The conversion formulas can be found in Section [“Water content of background gas”](#), page 41.



NOTE: Adapting compensation values to ambient conditions

- When humidity and CO₂ compensation is/are activated, and when the ambient conditions deviate from the ambient conditions during adjustment:
 - 1 Set the water and CO₂ content according to the adjustment environment.
 - 2 These settings then have to be changed back to represent those of the operating conditions when the TRANSIC151LP is reinstalled in the process.



NOTE: Deactivating humidity and CO₂ compensation

- ▶ Set the values for the water and CO₂ content of the background gas to zero (factory setting).

Water content of background gas

The dependency on water content is expressed as absolute humidity in $\text{g/m}^3 \text{H}_2\text{O}$ because relative humidity is strongly dependent on the temperature.

► Calculate the absolute humidity in $\text{g/m}^3 \text{H}_2\text{O}$ with the following equations:

$$\text{H}_2\text{O} (\text{g/m}^3) = C \times P_W / T$$

T	=	gas temperature in K (= 273.15 + T °C)
P_W	=	water vapor pressure in hPa
C	=	216.679 gK/J

$$P_W = P_{WS} \times \text{RH}(\%) / 100$$

r.h.(%)	=	relative humidity and P_{WS} = saturation pressure of the water vapor, or
---------	---	---

$$P_{WS} = 1000 \times 10^{28.59051 - 8.2 \log T + 0.0024804 T - 3142/T}$$

T	=	as specified above
---	---	--------------------

Example for calculating absolute humidity in g/m^3 :

Gas temperature is 40 °C and relative humidity is 90%.

- 1 First calculate the water vapor pressure
 $P_W: P_W (\text{hPa}) = P_{WS} (40 \text{ °C}) \times 90/100 = 66.5$
- 2 Use this result to calculate absolute humidity:
 $\text{H}_2\text{O} (\text{g/m}^3) = 216.679 \times 66.5 / (273.15 + 40 \text{ °C}) = 46.0$



The water content of the background gas influences the oxygen measuring result.

- 1 The water molecules contained by the background gas displace a certain amount of oxygen molecules.
- 2 Collisions between the water and oxygen molecules affect the shape of the oxygen absorption lines.

The first effect is the dilution of the oxygen concentration of the measured gas (water displaces oxygen so there is a lower oxygen concentration in the measured gas). This is not compensated during measurement. Only the second effect is due to the measuring principle and can be compensated.

The dependency due to the measuring principle is shown in the 4th column of “[Table to convert temperature and relative humidity to absolute humidity](#)”. This is compensated and eliminated when a value is specified for H_2O compensation.

The 5th column of “[Table to convert temperature and relative humidity to absolute humidity](#)” shows the dilution effect. This effect is much stronger than the measuring principle effect. This is also valid for the water content compensation because it is the actual decrease of oxygen content in the measured gas due to water displacing oxygen in the gas mixture.

Fig. 31: Table to convert temperature and relative humidity to absolute humidity

T °C	% r.h.	g/m ³ H ₂ O	Effect of humidity on measured O ₂ values (% of measured value)	
			Dependency	Dilution
-20	50	0.5	0.0	-0.1
-20	90	1.0	0.0	-0.1
0	50	2.4	-0.1	-0.3
0	90	4.4	-0.2	-0.5
25	50	11.5	-0.4	-1.6
25	90	20.7	-0.7	-2.8
40	50	25.6	-0.9	-3.6
40	90	46.0	-1.6	-6.6
60	50	64.9	-2.1	-9.8
60	90	116.8	-3.6	-17.7
80	50	145.5	-4.2	-23.4
80	90	262.0	-6.3	-42.1

Setting the CO₂ concentration in background gas

The effect of CO₂ on the measured O₂ value is so small that in most circumstances CO₂ compensation is not necessary. The CO₂ dependency is expressed in terms of relative CO₂ concentration (percent per volume CO₂).



NOTE:

The gas pressure value must be specified for CO₂ compensation.

Setting the carbon dioxide content for compensation

Enter using the keypad, see [“CO₂ content in process gas \(CO₂\)”, page 37](#).

Influence of further background gases

For further information on the influence of further background gases on oxygen measurement, see [“Influence of background gases on oxygen measurement”, page 79](#).

6 Adjustment

Definitions:

- Calibration: The comparison between the TRANSIC151LP measured value and a reference concentration.
- Adjustment: Changing the TRANSIC151LP measured value so that it corresponds to the reference concentration.



Read the instructions through carefully before making any settings or parameter changes. Endress+Hauser accepts no responsibility for parameter or setting changes nor adjustments made by the user. Contact Endress+Hauser Customer Service should you require technical support or assistance.



CAUTION: Differences between calibration and adjustment of the different TRANSIC151LP variants

Calibration and adjustment of the variants for installation in processes and with sample gas cells differ slightly from calibration and adjustment of the ambient gas measurement variant. Make sure you read the correct Section. *Section 8 covers calibration and adjustment of the ambient gas measurement variant.*



WARNING: Observe safety information!

see “Safety information”, page 18 and “Safety notes”, page 56.



NOTE: Risk of damage to the TSA151 through dust or humidity

► Only open the TSA151 in a dry environment free from dust.

6.1 Hardware preparations

Fig. 32: TRANSIC151LP in process



1 = Front of the device

2 = Allen screws

Getting started

- 1 Switch the TRANSIC151LP on at least 15 minutes before calibration or adjustment.
- 2 Calibration: Observe the measured values displayed for the TRANSIC151LP.
- 3 Adjustment is carried out using the keypad on the front TRANSIC151LP side:
 - Open the front TRANSIC151LP cover with a 4 mm hex socket (Allen) key.
 - Connect the gas supply, see “Setting up the gas supply for calibration and adjustment”, page 44 and calibrate/adjust according to the description in “Calibration”, page 53, and/or “Adjustment”, page 54.

6.1.1 Setting up the gas supply for calibration and adjustment

The TRANSIC151LP can be calibrated and adjusted with ambient air or bottled gas.

6.1.1.1 Using ambient air

See [“Using ambient air”, page 53](#) for further information on this calibration method.

6.1.1.2 Using bottled gas and with sample gas cell

- 1 Ensure the O-ring is seated securely in the groove.
- 2 Insert the probe into the sample gas cell.
- 3 Push the probe against the sample gas cell and turn it clockwise 45°, see [“Fastening the TRANSIC151LP probe in the sample gas cell”](#).
- 4 The gas inlets of the sample gas cell are fitted with Swagelok gas connections for \varnothing 6 mm tubes, see [“Installing the sample gas line”, page 23](#). A 6 mm \leftrightarrow 1/4“ adapter is delivered.
- 5 Let the gas flow out without hindrance. This avoids an overpressure in the chamber.

Fig. 33: Fastening the TRANSIC151LP probe in the sample gas cell

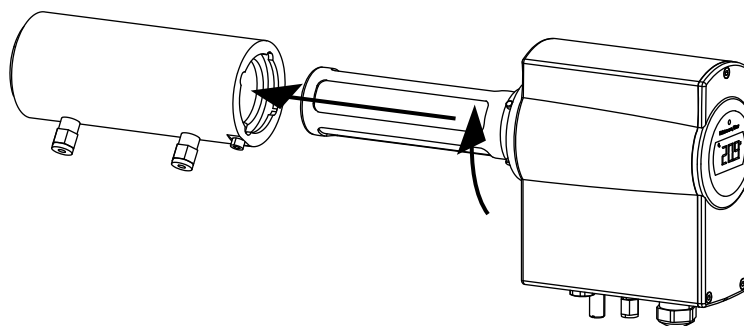

6.1.2 Calibration and adjustment in the process



NOTE: For adjustment in the process, fit an optional calibration gas inlet and PTFE filter on the TRANSIC151LP.

- ▶ The TRANSIC151LP does not have to be removed from the process with this adjustment method.
- ▶ Feed the reference gas through the optional calibration gas inlet in the bottom of the TRANSIC151LP transmitter.

Typical calibration accuracy is within $\pm 0.2\%$ O₂ for a reference gas volume flow of 5 ...9 l/min. Calibration uncertainty increases when the volume flow is significantly below 5 l/min.

The effect of the process gas flow rate (in the range 0 ... 20 m/s) on adjustment precision is negligible. Adjustment precision decreases with a higher process gas flow rate.

The strength of unwanted counter diffusion through the filter depends on the O₂ concentration difference between reference gas and process gas. For example, if you are using 100% N₂ as a reference and the process gas has 2% O₂, the result is better than when the process gas has 21% O₂.



- Use a sufficiently high reference gas volume flow for optimum adjustment results.
- With low reference gas volume flow, high adjustment precision is only achieved with process gas flow rates near zero.

6.1.2.1 Connections and systems

The calibration gas inlet of the TRANSIC151LP is fitted with a Swagelok screw fitting for pipes with 6 mm outer diameter. The non-return valve has an opening pressure of about 1.7 bar. The first opening pressure can be higher when the non-return valve has not been used for some time. Endress+Hauser therefore recommends using a flow monitor, e.g., a rotameter, to monitor the calibration gas flow.



WARNING: Escaping reference gas can enter the process

- ▶ Ensure the reference gas is compatible with the process gas.

6.1.2.2 Connecting the gas

- 1 Remove the plug of the TRANSIC151LP gas inlet.
- 2 Fasten the reference gas tube to the gas inlet. Do not overtighten the inlet.



NOTE: Prevent contamination of the gas inlet
If reference gas is not connected:

- ▶ Use a plug for the optional gas inlet of the TRANSIC151LP.
This prevents dust or dirt depositing on the gas inlet.



NOTE: Prevent process gas escaping!

If reference gas is not connected:

- ▶ Use a plug for the optional gas inlet.
Although the non-return valve prevents process gas from escaping, the plug on the optional gas inlet of the TRANSIC151LP can also be used.

6.1.2.3 Adjusting gas flow

- 1 Open the gas cylinder valve with care to avoid pressure surges.
- 2 Completely open the flowmeter.
- 3 Slowly increase the pressure setting of the controller until the gas flow can be detected with the rotameter
- 4 Use the flowmeter to adjust the flow rate to the desired value.
- 5 Pay attention to the flow rates for best adjustment precision.
For further information on adjustment precision and reference gas volume flow, see *Calibration and adjustment in the process on page 45*.
- 6 Observe Fig. Fig. 34 for adjustment without flowmeter. Information on the relation between reference gas volume flow and reference gas pressure of the optional calibration gas inlet can be found there.

Fig. 34: Volume flow against pressure, Swagelok SS-CHSM2-KZ-25 non-return valve

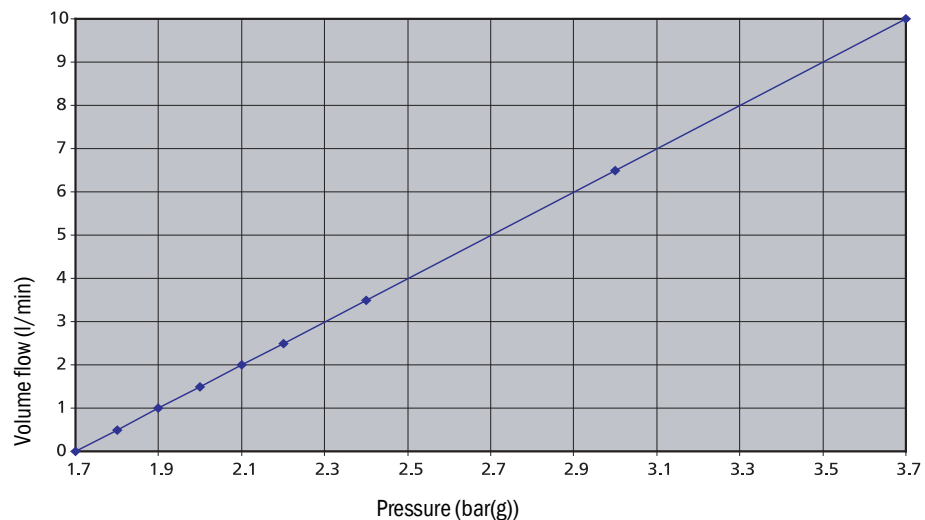

6.1.3 Information on calibration gases

- Factory calibration: Mixtures of dry N₂ and O₂.
- Humidity / CO₂ concentrations of calibration gases: 0%.
- Gases recommend for adjustment: Nitrogen gas mixtures.
- A flow rate of about 5 l/min is adequate for TRANSIC151LP calibration and adjustment. Shorter response times during calibration and adjustment require a higher volume flow. The higher the gas volume, the higher the gas pressure. Select an adequate tubing size for the escaping gas.



NOTE:

Allow enough time for the gas concentration to stabilize when doing calibrations/adjustments.

6.2 Calibration

The analog output can be frozen for calibration. Use function *Cal.C*, see “[Calibration gas, actual value \(CAL.C\)](#)”, page 35 with the keypad.

6.2.1 Using ambient air

- Normal ambient air provides a convenient way to calibrate the TRANSIC151LP because the oxygen concentration of dry ambient air is constant at 20.95% O₂.
 - ▶ Ensure the sensor is completely in the ambient air. Important: Pay attention to measured oxygen value of 21.0% O₂ ±0.2% O₂.
 - ▶ Correct the humidity.

[Table 3](#) shows the calibration display expected for the ambient air as function of the temperature (°C) and relative humidity (% r.h.).

The following Table shows the measured oxygen values (in % O₂) for a gas concentration of 20.95% O₂ with varying humidity values. The Table shows examples for measured values when measuring wet gases without r.h. corrections having been entered in the TRANSIC151LP measuring device (i.e., the relative humidity is set to 0% r.h.). Both gas dilution effect and r.h. dependency effect are included in the Table.

Temp (°C)	(% r.h.)										
	0	10	20	30	40	50	60	70	80	90	100
0	21.0	21.0	21.0	21.0	20.9	20.9	20.9	20.9	20.9	20.9	20.8
5	21.0	21.0	21.0	20.9	20.9	20.9	20.9	20.8	20.8	20.8	20.8
10	21.0	21.0	20.9	20.9	20.9	20.8	20.8	20.8	20.7	20.7	20.7
15	21.0	21.0	20.9	20.9	20.8	20.8	20.7	20.7	20.6	20.6	20.6
20	21.0	20.9	20.9	20.8	20.8	20.7	20.6	20.6	20.5	20.4	20.4
25	21.0	20.9	20.8	20.8	20.7	20.6	20.5	20.4	20.3	20.3	20.2
30	21.0	20.9	20.8	20.7	20.6	20.4	20.3	20.2	20.1	20.0	19.9
35	21.0	20.9	20.7	20.6	20.4	20.3	20.1	20.0	19.8	19.7	19.6
40	21.0	20.8	20.6	20.4	20.2	20.1	19.9	19.7	19.5	19.3	19.1
45	21.0	20.8	20.5	20.3	20.0	19.8	19.5	19.3	19.1	18.8	18.6
50	21.0	20.7	20.4	20.1	19.7	19.4	19.1	18.8	18.5	18.2	17.9
55	21.0	20.6	20.2	19.8	19.4	19.0	18.6	18.3	17.9	17.5	17.2
60	21.0	20.5	20.0	19.5	19.0	18.5	18.1	17.6	17.1	16.7	16.2
65	21.0	20.4	19.7	19.1	18.5	17.9	17.3	16.8	16.2	15.6	15.1
70	21.0	20.2	19.4	18.7	17.9	17.2	16.5	15.8	15.1	14.4	13.8
75	21.0	20.0	19.1	18.2	17.3	16.4	15.5	14.7	13.8	13.0	12.2
80	21.0	19.8	18.7	17.5	16.5	15.4	14.4	13.4	12.4	11.4	10.4

Table 3: Oxygen measured values for relative humidity

6.2.2 Using bottled gas

- Preparation for calibration with bottled gas, see [“Setting up the gas supply for calibration and adjustment”](#), page 44, title *Gas flow adjustment*.
- When calibration conditions (gas pressure, humidity and CO₂ concentration) are different from the operating conditions of the TRANSIC151LP, set the ambient parameters of the TRANSIC151LP to the adjustment environment for the adjustment duration. These settings must then be changed back to represent the process conditions when the TRANSIC151LP is reinstalled in its operating environment.
- Let the gas flow in.
- Wait until the measured value has stabilized.
- Now compare the TRANSIC151LP display value with the calibration gas specification.
- Set the parameters for pressure, humidity and temperature corresponding to the process conditions.
- Ensure the analog output is no longer frozen.

6.3 Adjustment

6.3.1 Adjustment process

- 1 Enter the password, see [“Entering the password \(PAS\)”](#), page 36.
- 2 Access to the adjustment functions is open for 30 minutes after the password is entered. Functions in progress are not interrupted after expiry of 30 minutes. Enter the password again to execute more password-protected functions.
- 3 Make sure that no error messages are active as these could affect adjustment. Malfunction messages, see [“Display of active and undeleted errors \(ERR\)”](#), page 35.
- 4 Make sure that the ambient parameters of the adjustment environment have been set before adjustment.
- 5 Set the values for pressure, humidity and CO₂ concentrations of the calibration gas. Calibration gases have a humidity of 0 g/m³ H₂O. The CO₂ concentration of nitrogen gas mixtures is 0 vol% CO₂.
- 6 Reset the ambient parameters after adjustment to the values of the process gas. Further information on the compensation of ambient parameters can be found in [“Compensation of ambient parameters”](#), page 39.

6.3.2 Adjustment options

- One-point adjustment using the keypad
- Two-point adjustment using the keypad
- Restoring factory calibration



- The reference concentration used determines whether the gain or offset parameter value is changed.
 - Change to the offset value: Oxygen concentration < 10.5% O₂
 - Change to the gain value: Oxygen concentration > 10.5% O₂
- Two-point adjustment: Always returns new gain and offset values.

6.3.3 One-point adjustment using the keypad (function CAL1)

- 1 Check that no error messages are active. Active error messages influence adjustment. Malfunction messages, see [“Display of active and undeleted errors \(ERR\)”](#), page 35 (keypad). Error Table, see [“Error Table”](#), page 63.
- 2 Enter the password in menu *PAS*, see [“Entering the password \(PAS\)”](#), page 36.
- 3 Select menu item *Cal1*. This freezes the analog output.
- 4 Connect the reference gas.
- 5 Enter the known O₂ value and confirm with *Ent*.
- 6 The measured value display blinks.
- 7 Feed calibration gas.
- 8 Wait until the display shows a stable value.
- 9 Confirm with *Ent*.
PASS is displayed when the calibration is successful. The TRANSIC151LP now calculates the new gain and offset settings and starts to display the new measured value.
- 10 Press *Ent* twice. *This ends the one-point adjustment.*

Fig. 35: One-point adjustment using the keypad

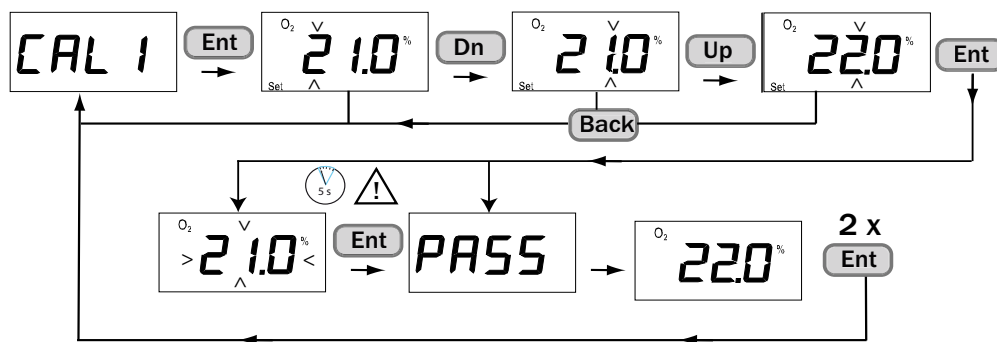

The adjustment can be aborted at any time with *Back*.

6.3.4 Two-point adjustment using the keypad (function CAL2)

The procedure is the same as for one-point calibration but the adjustment continues automatically with the second reference point.

This adjustment calculates and sets new gain and offset parameter values. This process uses one gas to adjust the lower limit value of the measuring range and another gas to adjust the upper limit. These can be, for example, pure nitrogen (0.0% O₂) and an N₂/O₂ mixture (for example, 21% O₂). The minimum difference between the two reference gas concentrations in two-point adjustment should be at least 4% O₂.

When adjustment conditions (gas pressure, humidity and CO₂ concentration) are different from the operating conditions of the TRANSIC151LP, set the ambient parameters of the TRANSIC151LP to the adjustment environment for the adjustment duration. These settings must then be changed back to represent the process conditions when the TRANSIC151LP is reinstalled in its operating environment. Further information on setting the ambient parameters of the TRANSIC151LP, see “Process pressure: Display and settings (APP)”, page 36 and “H₂O content in the process gas (H2O)”, page 36.

- 1 Check that no error messages are active.
Active error messages influence adjustment. Malfunction messages, see “Display of active and undeleted errors (ERR)”, page 35 (keypad). Error Table, see “Error Table”, page 63.
- 2 Select menu item *Cal2*. This freezes the analog output.
- 3 First close off the gas for the *first (lower limit)* reference point.
- 4 Enter the known reference gas value and confirm with *Ent*.
- 5 The measured value display blinks.
- 6 Feed calibration gas.
- 7 Wait until the display shows a stable value.
- 8 Enter the known reference gas value and confirm with *Ent*.
- 9 Now close off the gas for the *upper limit* reference point.
- 10 Confirm with *Ent*. The display now shows *Set hi.* and the adjustment for the second (upper) reference point starts and “Set Hi 10.0%” is displayed.
PASS is displayed when the adjustment is successful. The display now shows the O₂ value when no further input is made.
- 11 The TRANSIC151LP now calculates the new gain and offset settings and starts to display the new measured result.
- 12 Press *Ent* twice. *This ends the two-point adjustment.*

Fig. 36: Two-point adjustment using the keypad

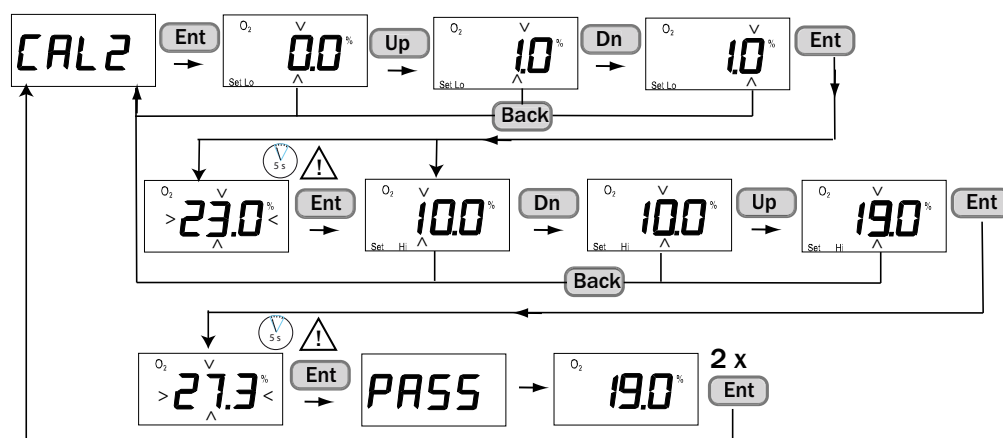

The adjustment can be aborted at any time with *Back*.

6.4 Adjustment for TRANSIC151LP ambient gas measurement



This Section solely describes the adjustment and calibration of the TRANSIC151LP variant for ambient gas measurement. Please read the complete Section 6 for comprehensive information on the calibration and adjustment procedure for the TRANSIC151LP for ambient gas measurement.



With the ambient measurement configuration, it is assumed that the probe and enclosure are installed in an environment with a varying O₂ concentration. This presents special demands on calibration and adjustment of the TRANSIC151LP variant for ambient gas measurement because the calibration and adjustment gas should be present in both the probe and the enclosure. Endress+Hauser recommends the following procedure for a simpler approach:

- For calibration (test of TRANSIC151LP): Use normal ambient air or 21.0% O₂ calibration gas, see [“Calibration”, page 53](#).
- For adjustment: Use one-point adjustment with 21.0% O₂ adjustment gas and sample gas cell, see [“Adjustment”, page 54](#).



Endress+Hauser recommends using ambient air for calibrating the TRANSIC151LP variant for ambient gas measurement. See [“Calibration”, page 47](#).

6.4.1 Setting up the gas supply

This TRANSIC151LP version requires the calibration and adjustment gas to be present in the probe as well as inside the measuring device enclosure.

This requirement is most easily fulfilled by performing calibration and adjustment with gas that has an O₂ concentration close to normal ambient air O₂ concentrations (20.95% O₂).

When using calibration or adjustment gas concentrations significantly different from ambient air, it should be noted that:

- For calibration (test of device), it is possible to correct the error in the measured value of the measuring device caused by the calibration configuration.

Take the required measures for adjustment so that the adjustment gas concentration is also present in the measuring device enclosure.

Using ambient air

For further information on the calibration method, see [“Using ambient air”, page 53](#).

Using bottled gas and with sample gas cell

- 1 Ensure the O-ring is seated securely in the groove.
- 2 Insert the probe into the sample gas cell.
- 3 Push it against the sample gas cell and turn it clockwise 45°, see [“Fastening the TRANSIC151LP probe in the sample gas cell”, page 44](#).
- 4 The gas inlets of the sample gas cell are fitted with 1/8" NPT or Swagelok gas connections for Ø 6 mm tubes, see [“Installing the sample gas line”, page 23](#).
- 5 Let the gas flow out without hindrance. This avoids an overpressure in the chamber.

6.4.2 Calibration

The analog output can be frozen for calibration. Use function *Cal.C*, with the keypad as described on [Page 34](#).

6.4.2.1 Using ambient air

For information on calibration with ambient air, see [“Using ambient air”, page 47](#).

6.4.2.2 Using bottled gas

- Preparations for calibration with bottled gas can be found under the title *Gas flow adjustment* in Section [“Setting up the gas supply for calibration and adjustment”](#).
- When calibration conditions (gas pressure, humidity and CO₂ concentration) are different from the operating conditions of the TRANSIC151LP, set the ambient parameters of the TRANSIC151LP to the adjustment environment for the adjustment duration. These settings must then be changed back to represent the process conditions when the TRANSIC151LP is reinstalled in its operating environment.
- Let the gas flow in.
- Wait until the measured value has stabilized.
- Now compare the TRANSIC151LP display value with the calibration gas specification.

The TRANSIC151LP does not show calibration gas concentration completely correctly because only the probe is in the calibration gas. The correct measured value can be taken from the Figure [“TRANSIC151LP measured values dependent on the O₂ concentration in calibration gas”, page 53](#) for this configuration.

The Figure shows the measured value when only the sample gas cell (and not the measuring device enclosure) is exposed to the calibration gas.

- Set the parameters for pressure, humidity and temperature corresponding to the process conditions.
- Ensure the analog output is no longer frozen.

Fig. 37: TRANSIC151LP measured values dependent on the O₂ concentration in calibration gas

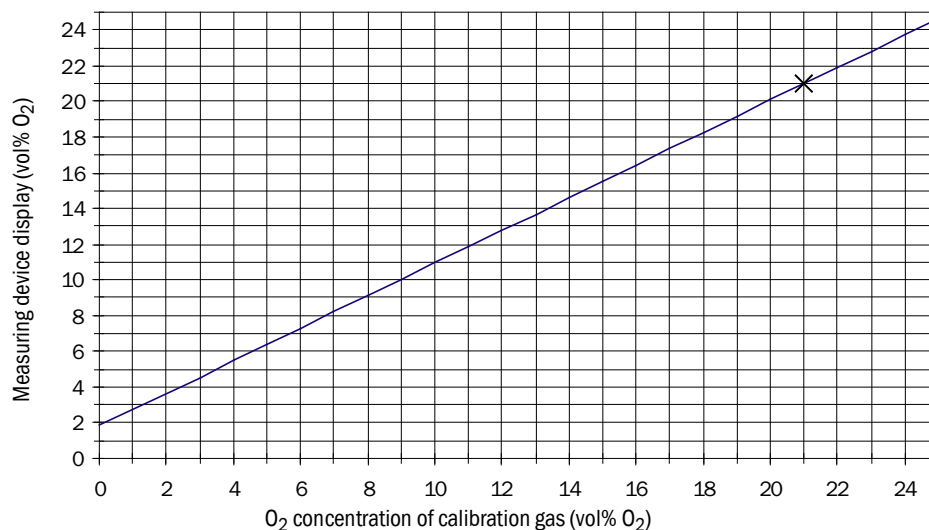

6.4.2.3 Information on calibration gases

- Factory calibration: Mixtures of dry N₂ and O₂.
- Humidity / CO₂ concentrations: 0%.
- Gases recommend for adjustment: Nitrogen gas mixtures.
- When using the sample gas cell: Volume flow for calibration and adjustment about 0.5 l/min higher volume flow for shorter response times. The higher the gas volume, the higher the gas pressure.
Select an adequate tubing size for the escaping gas.

**NOTE:**

Allow enough time for the gas concentration to stabilize when doing calibrations/adjustments.

6.4.3 Adjustment

Endress+Hauser recommends a one-point adjustment with a dry O₂/N₂ gas mixture with an O₂ concentration of about 21% O₂ for this TRANSIC151LP variant.

The adjustment gas concentration must be in both the probe and the enclosure of the TRANSIC151LP. Further information, see [“Adjustment”, page 49](#) and [“Setting up the gas supply”, page 52](#).

6.4.4 Adjustment options

- One-point adjustment (O₂ concentration at 21.0%) via the keypad.
- Restoring factory calibration.

6.4.5 One-point adjustment using the keypad (function CAL1)

When adjustment conditions (gas pressure, humidity and CO₂ concentration) are different from the operating conditions of the TRANSIC151LP, set the ambient parameters of the TRANSIC151LP to the adjustment environment for the adjustment duration. These settings must then be changed back to represent the process conditions when the TRANSIC151LP is reinstalled in its operating environment. [see “Setting ambient parameters”, page 39](#) for further information on setting ambient parameters for the TRANSIC151LP.

- 1 Check that no error messages are active.
Active error messages influence adjustment. Malfunction messages, [see “Error display”, page 63](#). Error Table, [see “Error Table”, page 63](#).
- 2 Enter the password in menu *PAS*.
- 3 Select menu item *Cal1*. This freezes the analog output.
- 4 Connect the reference gas.
- 5 Enter the known O₂ value and confirm with *Ent*.
- 6 The measured value display blinks.
- 7 Feed calibration gas.
- 8 Wait until the display shows a stable value.
- 9 Confirm with *Ent*.
PASS is displayed when the calibration is successful. The TRANSIC151LP now calculates the new gain and offset settings and starts to display the new measured value.
- 10 Press *Ent* twice. *This ends the one-point adjustment.*

Fig. 38: One-point adjustment using the keypad.

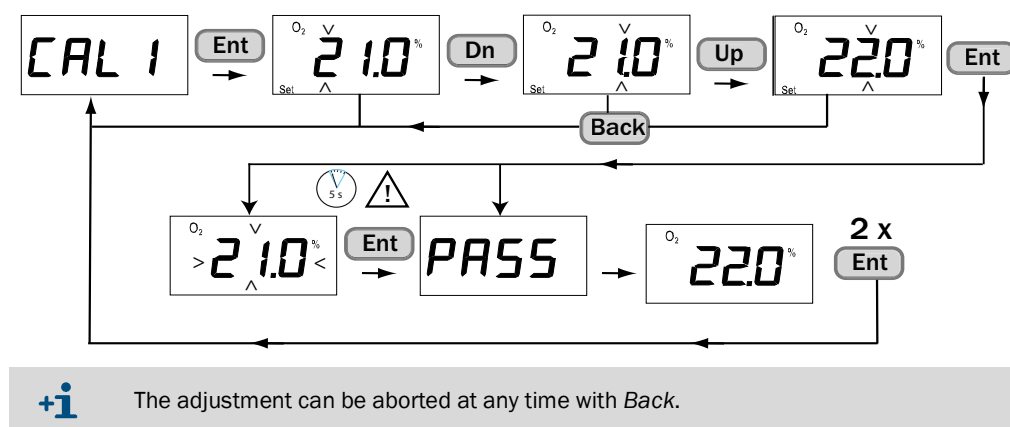

6.4.6 Restoring factory calibration

Restoring the TRANSIC151LP factory calibration via the keypad, [see “Resetting to the factory calibration \(FAC\)”, page 37](#).

7 Maintenance

7.1 Field maintenance

7.1.1 Assembly and disassembly

7.1.1.1 Safety notes



- ▶ Only use original Endress+Hauser spare parts.
- For devices used in potentially explosive atmospheres:
- ▶ Maintenance and inspection should only be carried out by experienced/trained personnel with knowledge of the rules and regulations for potentially explosive atmospheres, especially:
 - Ignition protection types
 - Installation regulations
 - Zone classification
 - ▶ Standards to be applied:
 - IEC 60079-14, Annex F: Knowledge, skills and competencies of responsible persons, operatives and designers.
 - IEC 60079-17: Electrical installations inspection and maintenance
 - IEC 60079-19: Equipment repair, overhaul and reclamation



WARNING: Risk of burns through hot gases

- ▶ With process temperatures > 65 °C, let the TRANSIC151LP cool down before starting maintenance work.



WARNING: Toxic gases escaping

- ▶ Ensure the seals are fitted.
- ▶ Incorrect sealing materials lead to leaks.
- ▶ Check the installation regularly for leaks.



WARNING: Risk of fire through reaction with oxygen

- ▶ Keep components with sample gas contact free from grease and dust.



WARNING: Risk of injury through pressure

- ▶ Only assembly and disassemble the TRANSIC151LP when free from pressure.



When necessary, provide separating elements to ensure safe installation and removal.



WARNING: Risk of explosion through use of an unsuitable flange

Oxygen measurement only functions in the range 0.8 to 1.4 bar(a). Do not use the flange with M5 screws when the pressure to be expected is above 1.5 bar absolute or the plant is designed for such pressures.

- ▶ Only use components designed for the process pressure in the application.
- ▶ Observe the components pressure conditions, see “Pressure suitability”, page 77
- ▶ Observe regional regulations



CAUTION: Laser beam invisible

- ▶ Switch the TRANSIC151LP off during cleaning

Cleaning tools positioned on the probe can reflect the laser beam coming out of the probe.

**WARNING:** Corrosive components can endanger operation

- ▶ Check all parts, especially those made of stainless steel, for corrosion and exchange these parts as necessary.

Corrosion on device parts can impair safety with regard to explosion protection, leak tightness and pressure.

**NOTE:** Risk of damage to the TRANSIC151LP through dust or humidity

- ▶ Only open the TRANSIC151LP in a dry environment free from dust.

**CAUTION:** Plant-specific hazards during maintenance work

- ▶ Observe local regulations with regard to plant-specific protective equipment during maintenance work.

7.1.2 Cleaning the optical components

Check the signal strength

- Maintenance of the TRANSIC151LP
- Maintenance warning
- Error signal that indicates excessive light loss in the sensor.
Inquiry via keypad, see [“Signal intensity\(SIL\)”, page 35](#).



NOTE: Endress+Hauser recommends cleaning the optical components when the signal strength is below 80%.

Using solvents to clean the optical components

When using solvents to clean the optical components, ensure the solvent used is compatible with the sealing material of the sensors.

Cleaning the mirror and lens

Fig. 39: Location of the mirror in the oxygen measuring probe

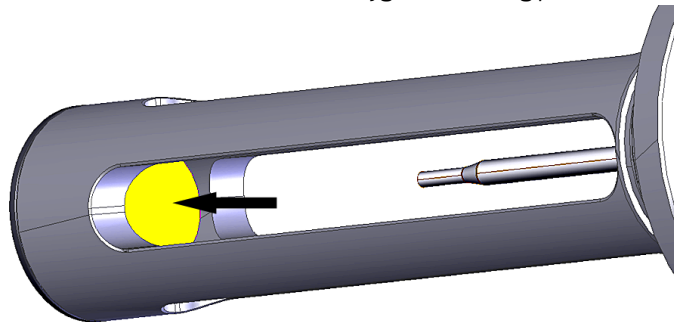
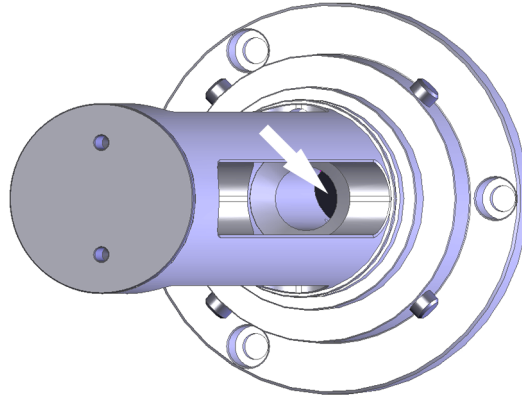

Fig. 40: Location of the lens in the oxygen measuring probe



NOTE: Do not damage the lens

The lens is located in a \varnothing 11.5 mm cavity and is difficult to access. (See arrow in Fig. 40)

- 1 Remove the filter. Instructions, see “Cleaning the filter”, page 60.
- 2 Use a jet of clean air to clean loose particles off the mirror (instrument air or better). Continue with step 3 when the optics are still contaminated.
- 3 Tip distilled water with soap mixed in onto the mirror and let it work.
- 4 Then rinse with distilled water.
- 5 Dry with compressed air (instrument air or better quality).
- 6 If the surface is still contaminated, tip pure ethanol or isopropanol onto the surfaces. Let the chemicals work in for maximum 15 minutes.
- 7 Rinse the optical components with distilled water after cleaning.
- 8 Dry with compressed air (instrument air or better quality).
- 9 After cleaning, the surface should appear clean without oil stains, contamination or dust. Refit the filters after cleaning.



NOTE: Damage to the lens and mirror through mechanical cleaning.

During the cleaning process described above, never attempt to clean the optical components by rubbing (e.g., with cotton swabs or cleaning a cloth).



Cleaning the TRANSIC151LP optics is easiest with an optics cleaning set from Endress+Hauser. Part No., see “Accessories”, page 61.

7.1.3 Checking the temperature probe



WARNING: Risk of explosion through damaged temperature probe

The temperature probe is part of the zone separation. The partition wall thickness of the temperature probe is $0.2 < t < 1$ mm.

- ▶ Ensure the temperature probe is not damaged by corrosive gas.

Fig. 41: Temperature probe

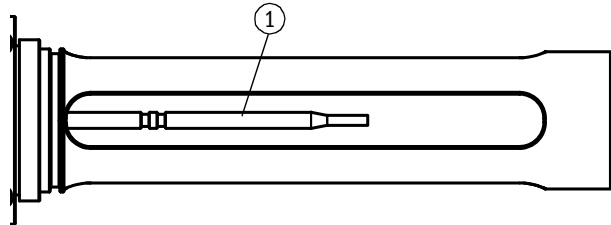

① Temperature probe

- ▶ Check the condition of the temperature probe during every regular maintenance.
- ▶ Exchange the temperature probe when corrosion can be seen. Contact Endress+Hauser Customer Service.

7.1.4 Cleaning the TRANSIC151LP filter



CAUTION: Control the filter regularly.

- ▶ Check the filter regularly.
- ▶ Change the filter when clogged.



WARNING: The filter can contain acidic or toxic substances

- ▶ Observe relevant safety regulations.
- ▶ Depending on its components, the filter must be disposed of according to legal regulations, or as hazardous waste when necessary.

Fig. 42: Stainless steel mesh and PTFE filters

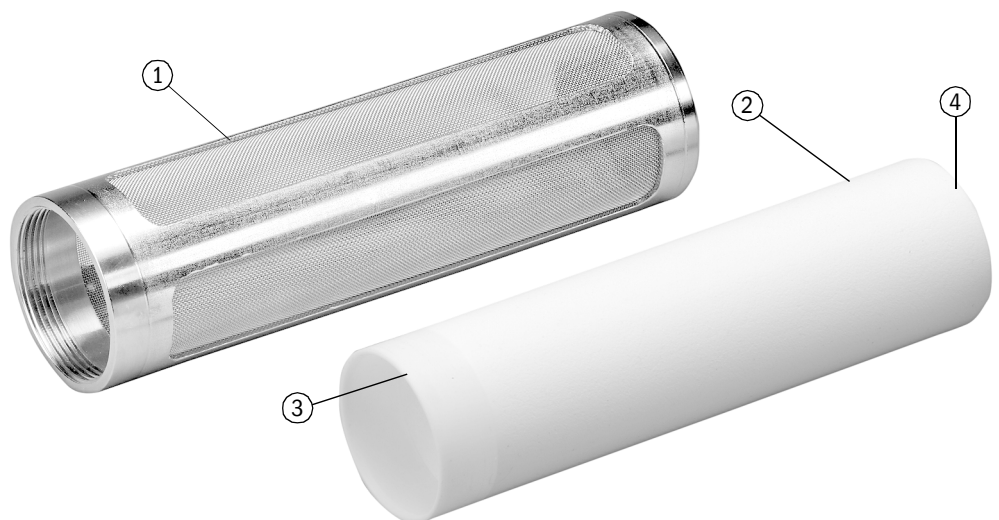

- ① Stainless steel mesh filter
- ② PTFE filter
- ③ + ④ Positions that can be touched by hand

7.1.5 Cleaning the filter

Cleaning the stainless steel mesh filter

- 1 Remove the filter from the TRANSIC151LP.
- 2 Clean the filter.
- 3 Dry the filter thoroughly.
- 4 Ensure air can flow through the filter mesh.
- 5 Refit the filter.

The stainless steel filter needs to be replaced when it remains dirty or clogged despite thorough cleaning. Part No., see [“Spare parts and accessories”, page 61](#).

PTFE filters



NOTE: Never touch the PTFE filter surfaces

- ▶ Only touch the PTFE filter as marked in Figure [“Stainless steel mesh and PTFE filters”, page 59](#). Avoid touching, rubbing or scraping the active surfaces of the PTFE filter as this can clog the filter.

The PTFE filter protects the optical components against liquids and dust. It is permeable to water vapor and solvents.

Checking the PTFE filter

The PTFE filter needs to be checked and exchanged regularly to provide adequate gas flow to the sensor volume.

Exchanging the PTFE:

- 1 The PTFE filter is retained by an O-ring on the base of the transmitter probe. Grasp the filter firmly, slide it over the O-ring and pull the filter out. Only grip the filter as described above. Remove the used O-ring seal.
- 2 Replace the O-ring seal with a new one: Roll the seal carefully into the groove at the base of the oxygen measuring probe. Be careful not to damage the O-ring by excessive sliding or friction along the metal edges of the probe.
- 3 If the open filter end is to be lubricated to ease installation, only use inert, oxygen-compatible lubricants suitable for seals and the process, such as, for example, DuPont Krytox®. Slide and lock the filter into place by holding the filter only by the solid part at the open end of the filter or (if necessary) by pressing at the closed tip of the filter with your fingers.

7.2 Spare parts and accessories

Spare parts

Designation	Order code
Set, flange seal, FKM	2064909
Set, flange seal, GYLON	2060195
Set, O-ring 47* 2, FKM (bayonet connection)	2064907
Set, O-ring 47* 2, KALREZ (bayonet connection)	2060193
Steel mesh filter	2060192
Set, steel mesh filter, PTFE filter, seal FKM	2064911
Set, steel mesh filter, PTFE filter, seal Kalrez	2060191
Set, O-ring 33.05* 1.78 FKM (filter)	2064917
Set, O-ring 33.05* 1.78 Kalrez (filter)	2060184
PTFE filter	2060181
Set, PTFE filter, seal FKM	2064918
Set, PTFE filter, seal Kalrez	2060099
Cable gland, M20*1.5 D 7 - 12 EX, brass nickel plated	5320471
Cable gland, M20*1.5 D 5 - 9 EX, PA-SW	5322249
Screw fitting (for Conduit), M20*1.5 to 1/2"NPTf, CUZN	2060179
TSA151 voltage supply unit, with M screw fittings	2066669

Accessories

Designation	Order code
Set, flange assembly, M5 FKM 0.5 bar	2064905
Set, flange assembly, M5 Kalrez 0.5 bar	2060196
Set, flange assembly, M8 FKM PN10	2068216
Set, flange assembly, M8 Kalrez PN10	2068214
Set, flange assembly, clamping flange, FKM PN10	2068359
Set, flange assembly, clamping flange, Kalrez PN10	2068225
Set, flange assembly, welding adapter, FKM PN10	2068358
Set, flange assembly, welding adapter, Kalrez PN10	2068224
Set, sample gas cell, PN10, with seal FKM	2064906
Set, sample gas cell, PN10, with seal Kalrez	2060194
Assembly bracket for sample gas cell wall fitting	4066692
Set, wall fitting	2060176
Interface cable, USB	2066710
Weather protection (flange assembly)	2065120
Weather protection (wall assembly)	2065084
Weather protection, voltage supply unit, TSA151, wall assembly	2066926
Power supply unit, PELV, class II, 100-240VAC/24V/50W	7028789
Line, 0.5 m, 3*2*0.5 Ex ib	2066791
Line, 2.0 m, 3*2*0.5 Ex ib	2066792
Line, 5.0 m, 3*2*0.5 Ex ib	2066793
Supply voltage isolator 24V, 4-20 mA EX	6051123
Isolating switching amplifier NAMUR EX	6051124
Optics, cleaning set	2072979

8 Troubleshooting

8.1 Function errors

The TRANSIC151LP monitors its operation. The monitoring includes:

- 1 Self-test
- 2 Error detection during operation
- 3 Error output

8.1.1 Self-test

A self-test is always carried out when the TRANSIC151LP is switched on.

External conditions can cause the self-test to fail, for example, when the lens or mirror are steamed up due to strong condensation in the probe. The signal level is insufficient. The TRANSIC151LP is reset after 10 minutes when the self-test fails due to external factors.

8.1.2 Error control and error categories

There are 3 error categories:

- *Serious errors:* Lead to a permanent error state.
- *Non-serious errors:* Are automatically deactivated when certain conditions are satisfied. These errors can also be deactivated manually.
- *Warnings:* Measurement continues but with maintenance request reported. Warnings can be deactivated manually.

All errors are always cleared during a start.

All error events are stored in an EEPROM error memory.

8.1.3 TRANSIC151LP behavior when errors occur

TRANSIC151LP	Serious error	Non-serious error	Warnings
Analog output	Programmable, Fail High or Fail Low	Programmable, Fail High or Fail Low Standard = 3 mA	Normal operation
LED	Red LED blinks rapidly	Red LED blinks slowly	Yellow LED blinks
NAMUR digital output	Open	Open	Closed; optional: Open when the digital output is used for signaling warnings.
Display	Error codes are displayed	Error codes are displayed	Measured value is displayed
Maintenance interface	STOP mode: Sends error message RUN mode: O2 value = ***.*** POLL mode: O2 value = ***.***	STOP mode: Sends error message RUN mode: O2 value = ***.*** POLL mode: O2 value = ***.***	STOP mode: Sends error message RUN mode: Normal operation POLL mode: Normal operation
Error counter	Error counter(s) incremented	Error counter(s) incremented	Error counter(s) incremented
Error log	Error is written to log	Error is written to log	Error is written to log

Table 4: Device status for error and warnings

Emergency shutdown state

If a processor or memory error occurs, the TRANSIC151LP switches to the emergency shutdown state and cannot be started:

Analog output	0.0 mA
LED	Red LED on
NAMUR digital output	Open

8.1.4 Error display

Via keypad, see “Display of active and undeleted errors (ERR)”, page 35.

8.1.5 Error Table

The Error Table shows the errors detected by the TRANSIC151LP software. The most severe errors are listed first. The error text associated with each error gives a description of the error cause.

Error No.	Error category	Error text	Cause
1	FATAL (serious)	EEPROM BASIC PARAMS NOT AVAILABLE (EEPROM basic parameters not available)	Error in EEPROM. (Contact Endress+Hauser Customer Service)
2	FATAL (serious)	EEPROM OPERATION PARAMS NOT AVAILABLE	Error in EEPROM. (Contact Endress+Hauser Customer Service)
3	FATAL (serious)	LASER CURRENT OUT OF RANGE	Error in laser control. (Contact Endress+Hauser Customer Service)
4	FATAL (serious)	SIGNAL LEVEL HIGH	Signal level high Typical: Light incidence too strong Use a filter, see page 61.
5	FATAL (serious)	LASER TEMPERATURE SENSOR FAILURE	Laser temperature sensor error (Contact Endress+Hauser Customer Service)
6	FATAL (serious)	GAS 1 TEMPERATURE SENSOR FAILURE	Temperature sensor error, process gas (Contact Endress+Hauser Customer Service)
7	FATAL (serious)	GAS 2 TEMPERATURE SENSOR FAILURE	Temperature sensor error, enclosure (Contact Endress+Hauser Customer Service)
8	FATAL (serious)	IO-EXPANDER CONNECTION	Hardware error (Contact Endress+Hauser Customer Service)
9	FATAL (serious)	LCD-DRIVER CONNECTION	No connection with display (Contact Endress+Hauser Customer Service)
10	FATAL (serious)	ADC2	Hardware error (Contact Endress+Hauser Customer Service)
11	FATAL (serious)	DIGIPOT CONNECTION	No connection with digital potentiometer (gain and offset control) (Contact Endress+Hauser Customer Service)
12	FATAL (serious)	PELTIER	Error in laser block/hardware error (Contact Endress+Hauser Customer Service)
13	FATAL (serious)	LASER CURRENT MEASUREMENT	Laser current error/hardware error (Contact Endress+Hauser Customer Service)
14	FATAL (serious)	FRONT END CONTROLS	Hardware error (Contact Endress+Hauser Customer Service)
15	FATAL (serious)	PELTIER CURRENT SENSE	Peltier current direction/hardware error (Contact Endress+Hauser Customer Service)
16	FATAL (serious)	VAC LIMIT REACHED	Laser aging allows wavelength to drift/hardware error (Contact Endress+Hauser Customer Service)
17	FATAL (serious)	SUPPLY VOLTAGES	Cabling problem between transmitter and TSA151 voltage supply unit. Check specifications for voltage supply unit and cables. See Technical Data, Page 75.

Table 5: Error Table

Error No.	Error category	Error text	Cause
31	NONFATAL (non-serious)	SIGNAL LEVEL LOW	Signal level low. Check optical components for contamination.
32	NONFATAL (non-serious)	SIGNAL CUT	Signal interrupted. Check optical path. Check optical components for contamination.
33	NONFATAL (non-serious)	LASER TEMPERATURE NOT REACHED	Laser temperature has not been reached. Check ambient conditions (temperature).
34	NONFATAL (non-serious)	PEAK LOST	Absorption line lost. Not enough oxygen in enclosure.
35	NONFATAL (non-serious)	TOO LOW SUPPLY VOLTAGE	Main supply voltage too low. Cabling problem between transmitter and TSA151 voltage supply unit. Check specifications for voltage supply unit and cables. See Technical Data, Page 75 .
36	NONFATAL (non-serious)	ANALOG OUTPUT LOAD TOO HIGH	Analog output load too high. Check specifications for voltage supply unit and cables. See Technical Data, Page 75 .
37	NONFATAL (non-serious)	NO MEASUREMENT RESULTS	No measuring results (results from other errors)
38	NONFATAL (non-serious)	ANALOG OUTPUT RANGE	Oxygen concentration value measured outside set output range. Adjust the output range settings when necessary.
51	WARNING	SIGNAL QUITE LOW	Transmission (SIL) <20% Maintenance request for optical components, see page 57 .
52	WARNING	EEPROM LOG&STATS CORRUPTED	Non-critical hardware error: EEPROM protocol and statistics erroneous. (Contact Endress+Hauser Customer Service)
53	WARNING	WATCHDOG RESET OCCURRED	Reset through software error.

Table 5: Error Table

8.2 LED displays on the TSA151

Fig. 43: LED displays on the TSA151 voltage supply unit

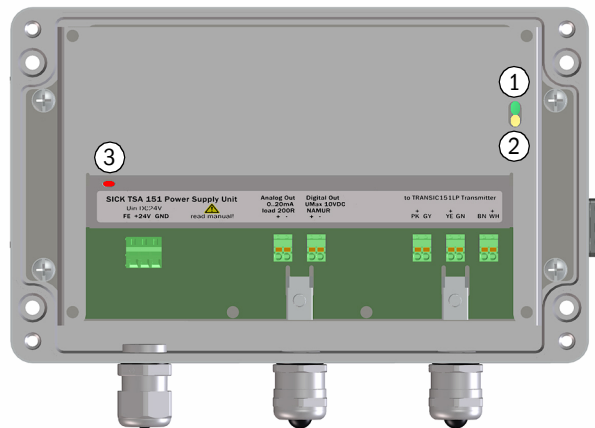

LED	Significance	Action
1 Green LED	TSA151 functions normally.	-
2 Yellow LED	Protective circuit has switched the current output off.	Switch the TSA151 off and on again.
3 Red LED	Fuse defective.	Exchange TSA151.

9 Shutdown

9.1 Safety information

- TRANSIC151LP: Open the display cover only for operation purposes. Never open the side covers when voltage is switched on.



CAUTION: Never divert the laser beam

Never insert an optical instrument into the measuring gap to possibly divert the laser beam whilst the TRANSIC151LP is switched on.

- TSA151 voltage supply unit: Do not open the cover when voltage is switched on!

All safety regulations for shutdown, see [“Safety information”, page 18](#) and in Section *Maintenance* on [“Safety notes”, page 56](#).

9.2 Preparations for shutdown

- ▶ Inform all connected locations.
- ▶ Passivate/deactivate the safety devices.
- ▶ Stop the inflow.
- ▶ Save the data.

9.3 Switching the TRANSIC151LP off

- ▶ Switch the TRANSIC151LP voltage supply off.

9.4 Protecting a shutdown TRANSIC151LP

- ▶ Store in a protected, dust-free and dry place.
- ▶ Observe the storage temperatures, see [“Ambient conditions”, page 73](#).

9.5 Disposal

- ▶ The TRANSIC151LP can easily be disassembled into its components which can then be sent to the respective raw material recycling facilities.
- ▶ Dispose of the TRANSIC151LP as industrial waste.



- ▶ Observe the respective valid local regulations for the disposal of industrial waste.
-

9.6 Shipping the TRANSIC151LP to Endress+Hauser



NOTE: Hazard through process residues on the device

- ▶ Clean the TRANSIC151LP before shipping to Endress+Hauser.
-

10 Specifications

10.1 Compliances

The technical design of this device complies with the following EU directives and EN standards:

- Directive 2014/30/EU (Low Voltage Directive, Harmonization of the laws)
- Directive 2011/65/EU (Restriction of the use of certain hazardous substances in electrical and electronic equipment – “RoHS”)
- EN 61326-1 (Electrical equipment for measurement, control and laboratory use – EMC requirements – Part 1: General requirements (IEC 61326-1:2012))
- EN 50581 (Technical documentation for the assessment of electrical and electronic products with respect to the restriction of hazardous substances)



Electrical protection

- Protection class III: Low voltage protection
- Electrical safety in accordance with DIN EN IEC 61010-1:2011.
- Supply with low voltage protection PELV (in accordance with EN 60204).
A 24V PELV power supply unit (with $U_m = 60V$) is mandatory for supplying the TSA151 to ensure electrical safety.

10.2 Ex Approvals



The TRANSIC151LP is suitable for the following zones
In accordance with ATEX (EN60079-10) and
In accordance with IECEx (IEC60079-10)

- Gas:
 - Measuring probe: Category 1G EPL Ga (Zone 0)
 - Transmitter / voltage supply unit: Category 2G EPL Gb (Zone 1)
- Dust:
 - Transmitter / voltage supply unit / measuring probe: Category 2D EPL Db (Zone 21)

The TRANSIC151LP may be used in zones in which inflammable or explosive gases in groups I, IIA and IIB or inflammable dust in groups IIIA, IIIB and IIIC are present.

- Temperature class:
 - Gas: T4 (max. surface temperature 135 °C)
 - Dust: T85 °C



Further information on Ex approval see “Explosion protection according to ATEX and IECEx”, page 15.



WARNING: Ex certification becomes void for unallowed power supply

- ▶ Only use the TSA151 voltage supply unit to run the TRANSIC151LP.
- ▶ Only use a 24V DC PELV power supply unit on the TSA151 voltage supply unit. (see “Special operating conditions”, page 10)
- ▶ Observe the “X” marking on the TSA type plate, see “Product identification”, page 11.

10.3 Approvals for pressure in Canada

CRN - Canadian Registration Number

Province	CRN
Alberta [1]	OF18864.52
British Columbia	OF18864.51
Manitoba	OF18864.54
Ontario	OF18864.5
Quebec	CSA-OF18864.56
Saskatchewan	CSA-OF18864.56

[1] Observe the following for product versions with clamping flange: When a clamping flange is used in Alberta, a clamping flange with CRN approval of a third-party supplier must be used.

Technical limit values for Canada

CRN No.	OF18864.51
Maximum Allowable Working Pressure (MAWP)	150 psi (10 bar(g))
Minimum Design Metal Temperature (MDMT)	-4 ... 176 °F (-20 ... 80 °C)

10.4 Technical Data



The TRANSIC151LP configuration depends on the application. Refer to the system documentation delivered with the TRANSIC151LP for the respective configuration.

10.4.1 Dimensions and bore patterns

Fig. 44: Wall bracket

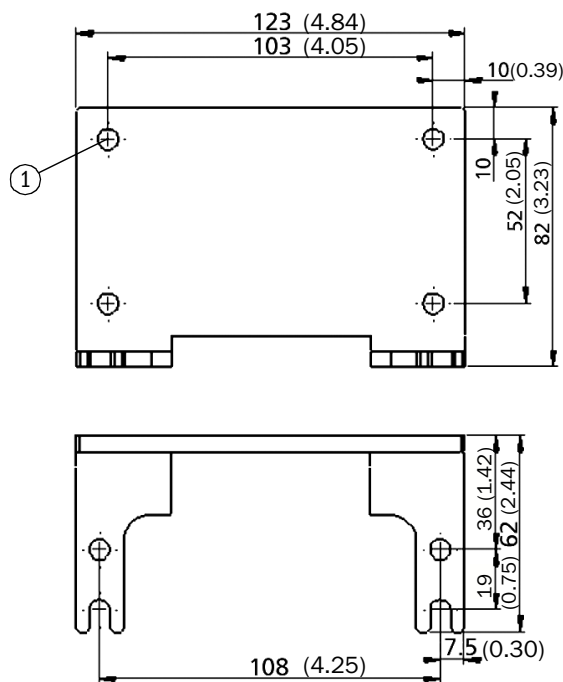

All specifications in mm (inches)

1 = ø 6.5 mm, four pieces

Fig. 45: Mounting flange with M5 bolts suitable up to 0.5 bar(g)

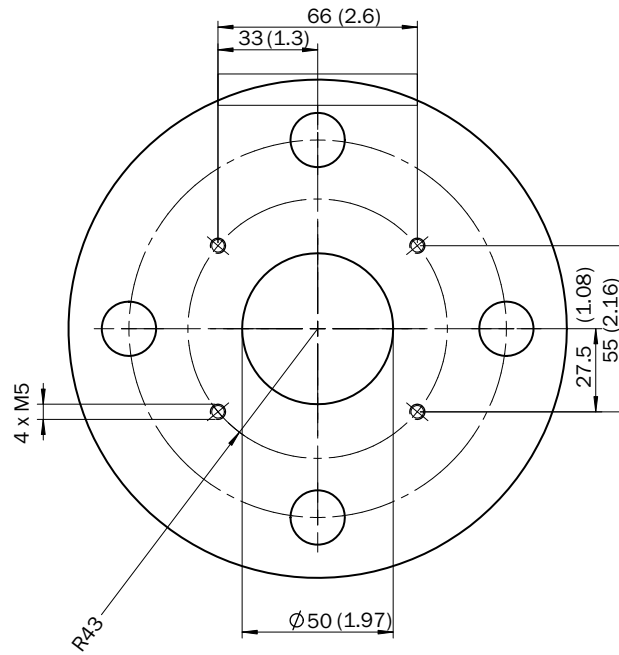

All specifications in mm (inches)



When installing with a tube with an outer diameter > 80 mm, do not drill M5 through-holes to prevent leakage from the process.

Fig. 46: Mounting flange with M8 bolts suitable for PS=10 bar (g)

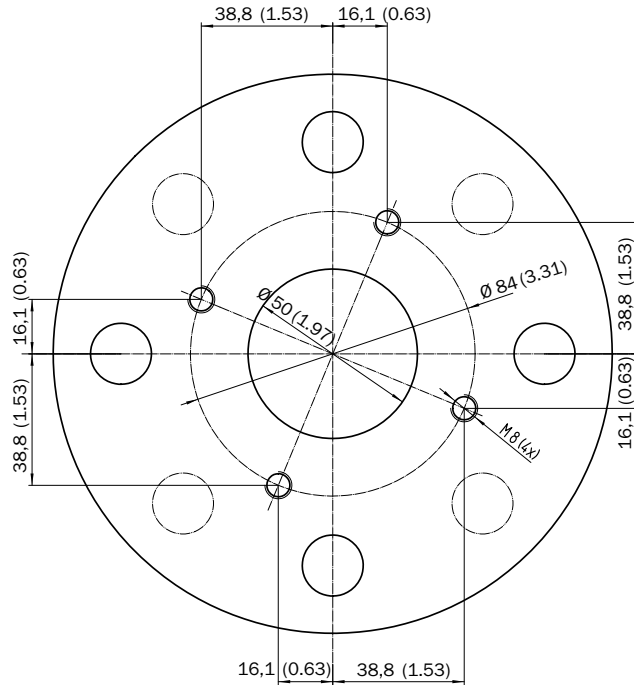

All specifications in mm (inches)

Fig. 47: Adapter flange, clamping flange DIN32676 3"/DN65, suitable for PS= 10 bar(g)

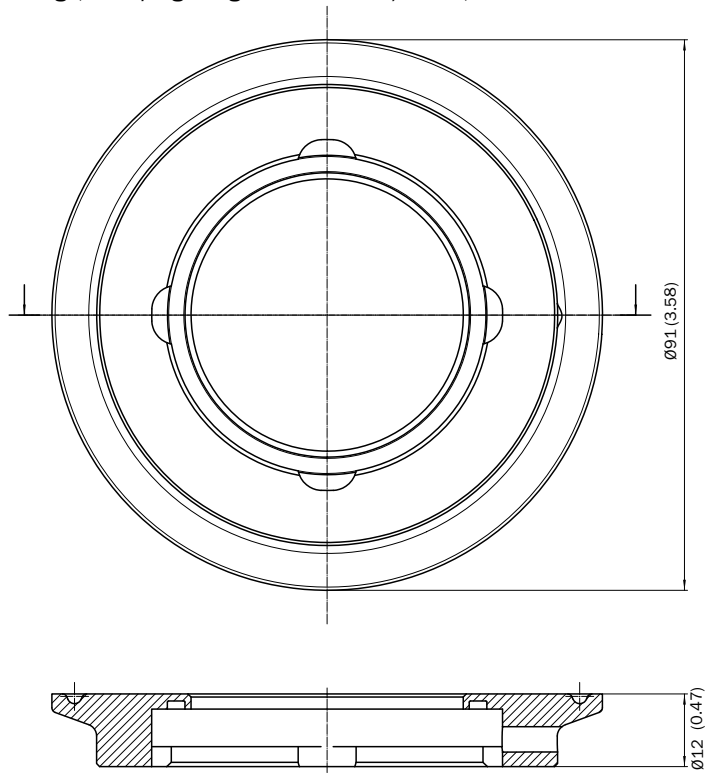

All specifications in mm (inches)

Fig. 48: Adapter flange, weldable, suitable for PS = 10 bar(g)

All dimensions in mm

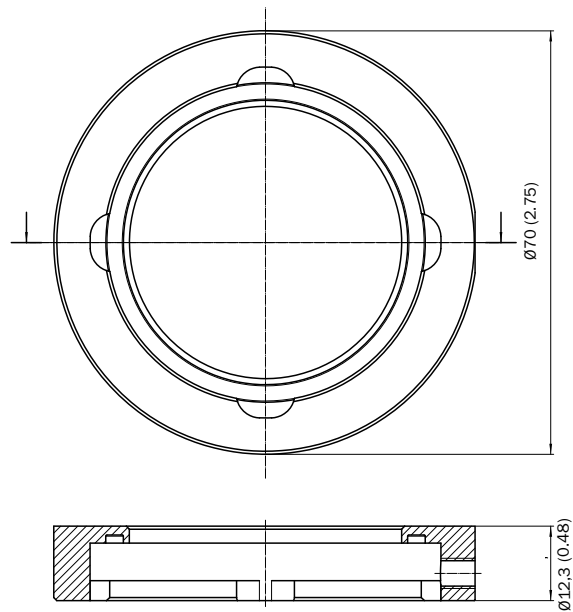

All specifications in mm (inches)

Fig. 49: TRANSIC151LP with flange adapter for process measurements

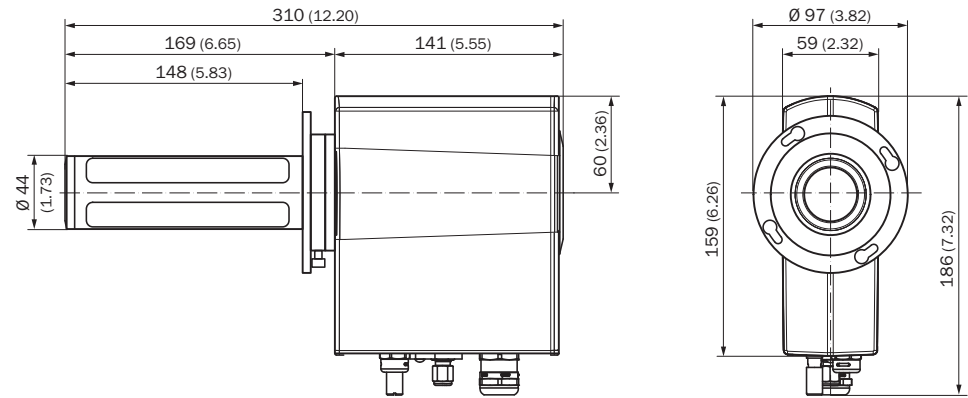

All specifications in mm (inches)

Fig. 50: TRANSIC151LP with wall bracket for ambient measurements

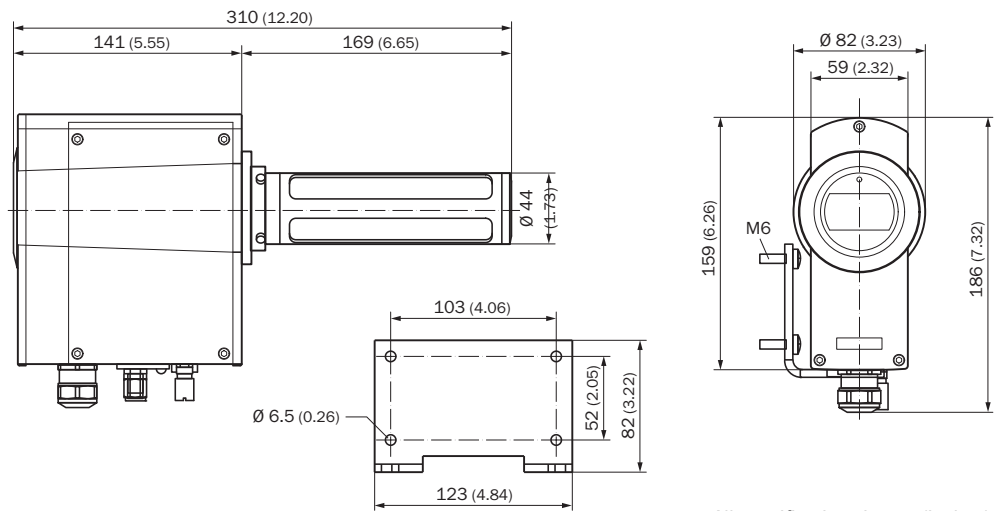

All specifications in mm (inches)

Fig. 51: TRANSIC151LP with wall bracket and sample gas cell (suitable for PS=10 bar(g))

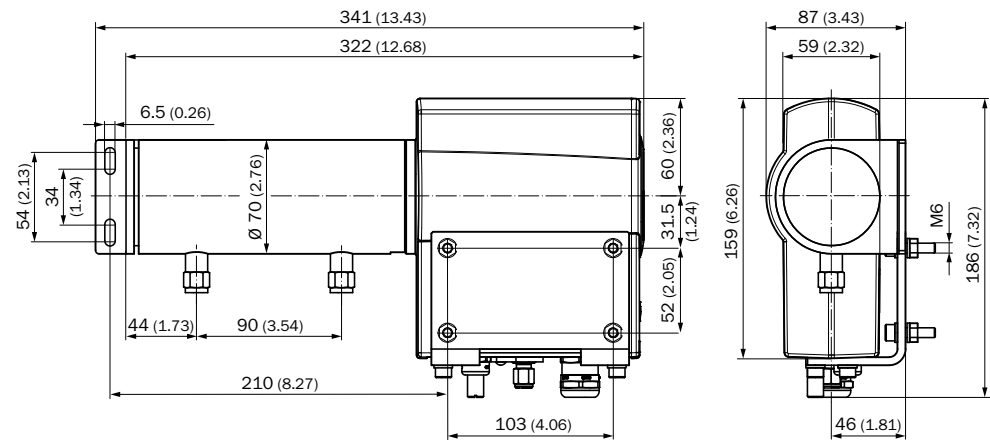

All specifications in mm (inches)

Fig. 52: Weather hood for wall installation

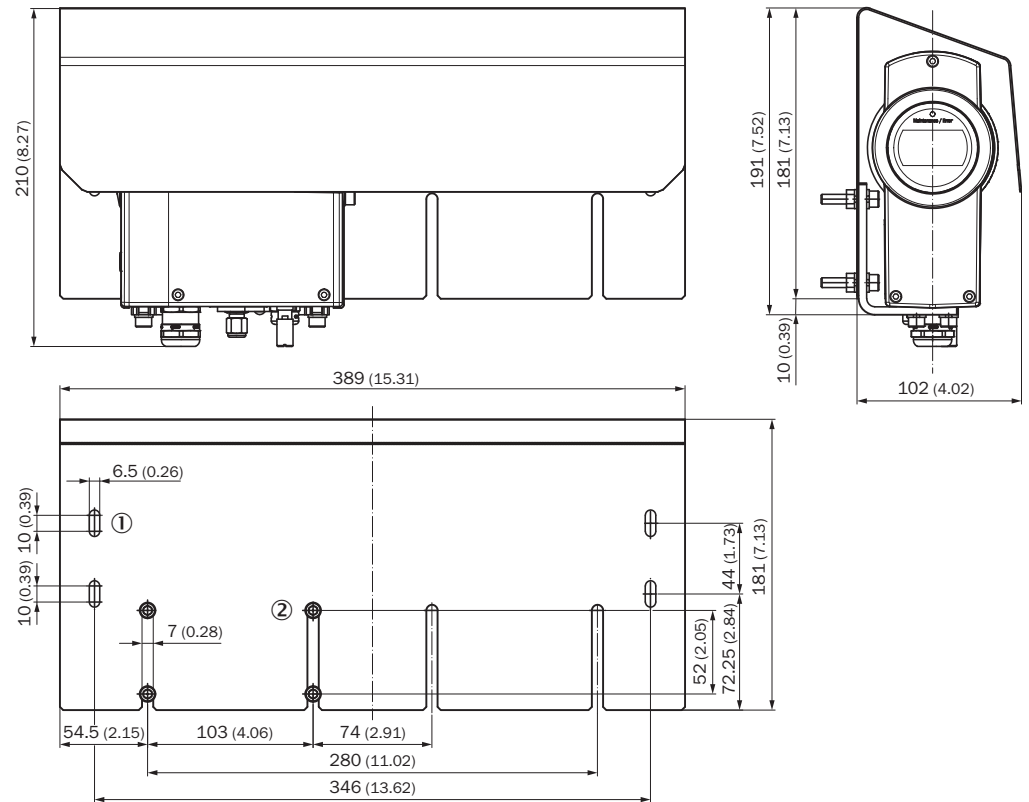

All specifications in mm (inches)

Fig. 53: Weather hood for flange installation

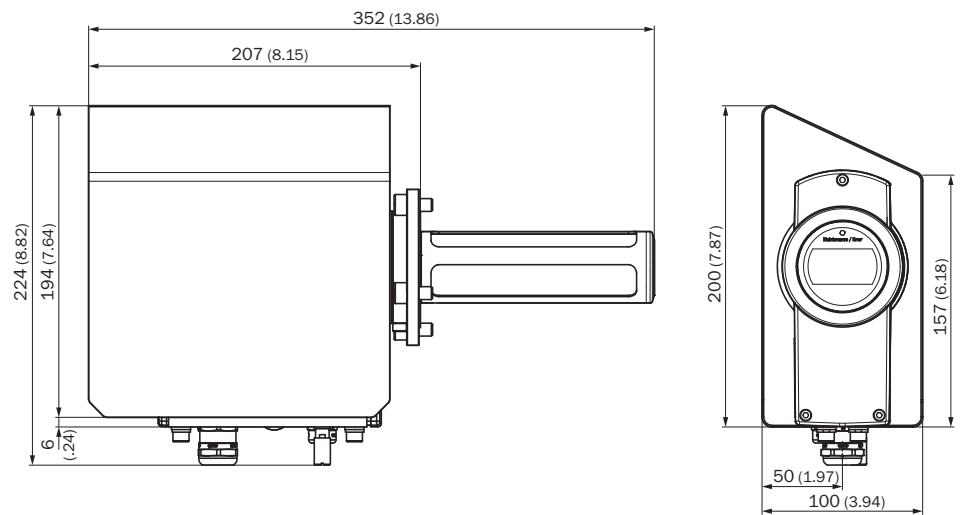

All specifications in mm (inches)

Fig. 54: TSA151 voltage supply unit

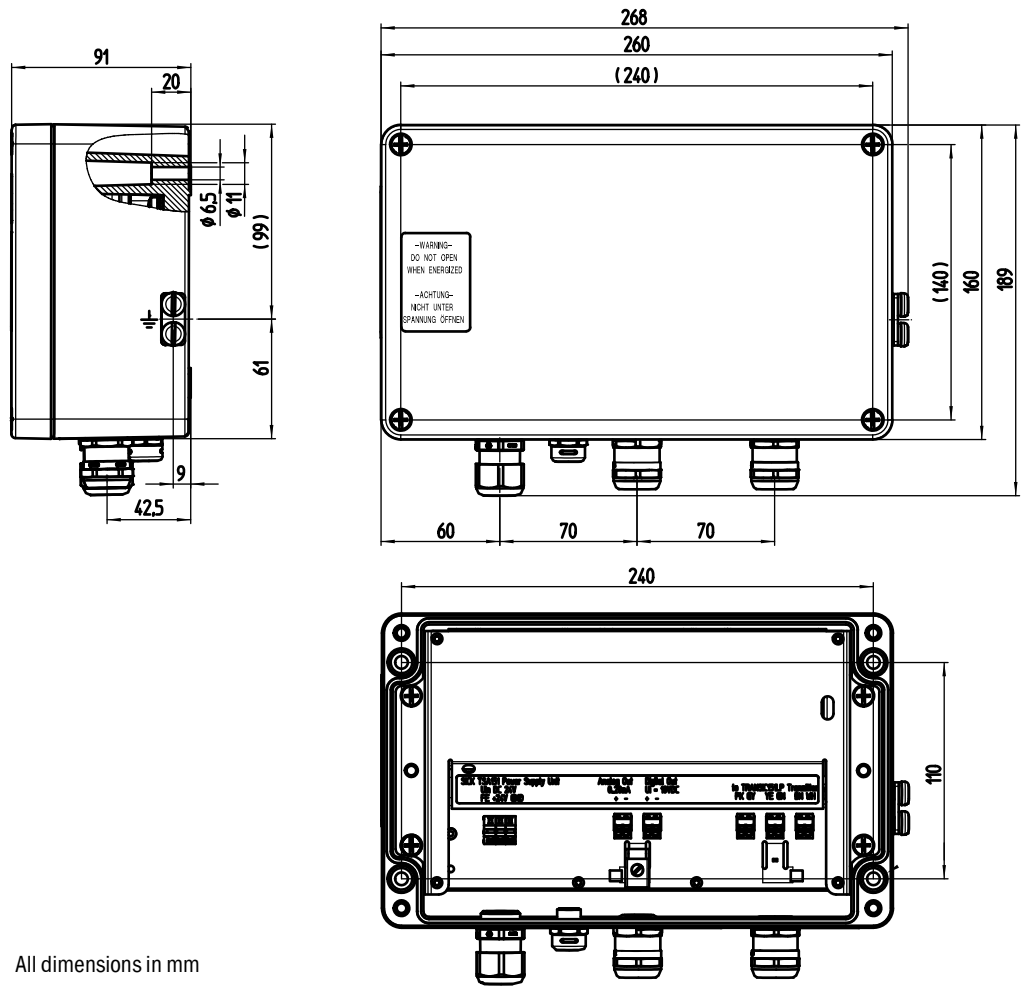

All dimensions in mm

10.4.2 Measured value recording

Measuring ranges (scalable) - In-situ and extractive version - Version for ambient gas measurement	0 ... 21 vol% O ₂ 2 ... 21 vol% O ₂
Precision	±0.2 vol% O ₂
Temperature dependence in T-range	±2 vol% of measured value, max. dT/dt 1 °C/min
Stability	Zero point drift ±0.1 vol% O ₂ / year Reference gas drift ±0.8 vol% from measured value / year
Measurement response time (T ₆₃ /T ₉₀) in still air - without filter - with stainless steel mesh - with stainless steel mesh and PTFE	10 s / 20 s 10 s / 25 s 30 s / 70 s
Operating pressure range	0.8 ... 1.4 bar(a)
Start time	2.5 min
Warming up time (according to specification)	3 min
Display	7-segment LCD
LED	Three-colored: Red/yellow/green

10.4.3 Ambient conditions

Operation location	Outdoors or indoors. No direct sunlight. Use a weather hood when necessary.
Operating temperature range - for probe (installed in process) - for electronics (housing) - for TRANSIC151LP voltage supply unit - for TRANSIC151LP (ambient air measurement)	-20 ... +80 °C -20 ... +60 °C -20 ... +60 °C -20 ... +60 °C
Storage temperature range	-40 ... +80 °C
Operating pressure range	0.8 ... 1.4 bar(a)
Air humidity	100% r.h. non-condensing
Altitude	Up to 2000 above sea level
Electrical compliance	In accordance with DIN EN IEC 61010-1:2011
Safety information	Laser product of protection class 1; see see "Main operating information", page 8 for information on eye-safe use of the TRANSIC151LP.

10.4.4 TRANSIC151LP electrical connection

Supply voltage range	7.5 V (supply only via TSA151)
Typical current consumption	360 mA
Typical power input	2.7 W

(Terminals) TRANSIC151LP connection data

Possible line cross-section on the connection terminals (zone Ex-ib)	Rigid:
	<ul style="list-style-type: none"> • Min. 0.5 mm² • Max. 1.5 mm²
	Flexible:
	<ul style="list-style-type: none"> • Min. 0.5 mm² • Max. 1.5 mm²
	Flexible with ferrule with plastic sleeve:
	<ul style="list-style-type: none"> • Min. 0.5 mm² • Max. 0.5 mm²
AWG:	
<ul style="list-style-type: none"> • Min. 20 • Max. 16 	
Connection type: Spring force	
Insulation stripping: 9 mm	

10.4.5 TRANSIC151LP safety-related technical characteristic data (IECEx/ATEX)**TRANSIC151LP voltage supply input**

Gas group	IIB
Maximum voltage U_i	8.25 V
Maximum current I_i	650 mA
Maximum performance P_i	5.37 W
Maximum inductance L_i	≈3.5 μH
Maximum capacity C_i	≈50 μF

TRANSIC151LP analog output

Maximum voltage U_o	8.25 V
Maximum current I_o	121 mA
Maximum performance P_o	250 mW
Maximum inductance L_o	5 mH
Maximum capacity C_o	1 μF

TRANSIC151LP switching output (NAMUR)

Maximum voltage U_i	10 V
Maximum current I_i	10 mA
Maximum performance P_i	100 mW
Maximum inductance L_i	≈3.5 μH
Maximum capacity C_i	≈132 nF

10.4.6 TSA151 voltage supply input

Supply voltage range	24 V \pm 10% (21.6 V DC ... 26.4 V DC)
Max. current consumption lin	240 mA
Max. power dissipation	6.3 W
Electric isolation	1500 V AC
Insulation voltage between input/output	

(Terminals) TSA151 connection data

Possible line cross-section on the connection terminals (zone Ex-ib)	Rigid:
	<ul style="list-style-type: none"> • Min. 0.14 mm² • Max. 1.5 mm²
	Flexible:
	<ul style="list-style-type: none"> • Min. 0.14 mm² • Max. 1.5 mm²
	Flexible with ferrule with plastic sleeve:
	<ul style="list-style-type: none"> • Min. 0.25 mm² • Max. 0.5 mm²
	AWG:
	<ul style="list-style-type: none"> • Min. 20 • Max. 16
	Connection type: Spring force
	Insulation stripping: 9 mm
Possible line cross-section on the connection terminals (zone Ex-e)	Rigid:
	<ul style="list-style-type: none"> • Min. 0.2 mm² • Max. 2.5 mm²
	Flexible:
	<ul style="list-style-type: none"> Min. 0.2 mm² Max. 1.5 mm²
	Connection type: Spring-loaded terminal
	Insulation stripping: 7 mm

10.4.7 TSA151 safety-related technical characteristic data (IECEX/ATEX)

Maximum voltage Um	60 V (through PELV power supply unit)
--------------------	---------------------------------------

TSA151 intrinsically safe output voltage

Gas group	IIB
Maximum voltage Uo	8.25 V
Maximum current Io	650 mA
Maximum performance Po	5.37 W
Maximum inductance Lo	Lo = 15 μ H
Maximum capacity Co	Co = 55 μ F

10.4.8 Connection lines

Connection line from TSA151 to TRANSIC151LP

Maximum line length	5 m
Maximum line cross-section	0.5 mm ² (flexible wire with ferrule)

Cable specifications	
Design	3 x 2 x 0.5 mm ² , shielded (shielding braid) and twisted as pair
Inductance L _c	≤ 1 mH/km
Capacity C _c	≤ 120 nF/km
Test voltage min.	≥ 500V AC / 750V DC
Conductor diameter	≥ 0.1 mm ^[1]
Outer diameter	7 ... 12 mm (M20 cable gland in scope of delivery)
Temperature range (flexible)	-20 °C ... +80 °C
Wire identification	In accordance with DIN47100

[1] Also valid for single wires of a fine-stranded conductor.



► Identify intrinsically safe power circuit (e.g., with light blue cable sheath).

Connection line from AO and DO on TSA151 to the isolation amplifiers

For maximum load of 200 Ohm	
Max. line length	400 m with 200 Ohm load (AO)
Max. line cross-section	0.5 mm ² (flexible wire with ferrule)

For maximum load of 150 Ohm	
Max. line length	800 m with 150 Ohm load (AO)
Max. line cross-section	0.5 mm ² (flexible wire with ferrule)

Cable specifications	
Design	2 x 2 x 0.5 mm ² , shielded (shielding braid) and twisted as pair
LC	≤ 1 mH/km
C _c	≤ 120 nF/km
Test voltage min.	≥ 500V AC / 750V DC
Conductor diameter	≥ 0.1 mm ^[1]
Outer diameter	7 ... 12 mm (M20 cable gland in scope of delivery)
Temperature range	-20 °C ... 80 °C

[1] Also valid for single wires of a fine-stranded conductor.

Connection line from 24 V PELV power supply unit to TSA151

- With line cross-section = 1 mm ²	Max. 100 m
- With line cross-section = 1.5 mm ²	Max. 150 m
Min. input voltage required on TSA151 input as well as losses on the line are considered.	

Cable specifications	
Design	2 x 1.0 mm ² oder 2 x 1.5 mm ²
Temperature range	-20 °C ... +80 °C
Outer diameter	5 ... 9 mm (M20 cable gland in scope of delivery)



A 24V PELV power supply unit with adjustable output voltage allows compensating losses on the line and therefore larger distances. Note that this is the responsibility of the operator/installer.

10.4.9 Dimensions and mechanics

Dimensions	TRANSIC151LP transmitter	TSA151 voltage supply unit
Dimensions (H × W × D)	306 × 184 × 74 mm ³	189 × 268 × 91 mm ³
Weight	2.2 kg	3 kg
Enclosure material	G-AISI10Mg (DIN 1725)	G-AISI12(Fe)
Enclosure classification	IP66	IP66
Flange	Can be attached to DIN/ANSI standard flanges. Minimum flange sizes: <ul style="list-style-type: none"> • DIN EN 1092 DN50: Fitted with M16 DIN933 or similar • ANSI ASME B16.5 (150) 2.5": Fitted with UNC 3/4"-10 or similar 	
Cable bushing	Cable gland M20×1.5	
Filter	<ul style="list-style-type: none"> • Stainless steel mesh, holes 0.31 mm, wire thickness 0.2 mm • Hydrophobic PTFE filter, average pore size 8 μm 	
Materials with sample gas contact	<ul style="list-style-type: none"> • AISI 316L(1.4404) • FKM or Kalrez® (optional) • PTFE, SiN, MgF₂, quartz glass • Polymer coating 	

10.4.10 Pressure suitability

For plant design ^[1]	<ul style="list-style-type: none"> • TS_{min}: -20 °C • TS_{max}: 80 °C • PS: 10 bar(g) • V: 0.28 L • DN: 50 ... 65 mm (2" ... 3")
---------------------------------	---

[1] Outside the measuring range (e.g., in error case); valid for transmitter, seals, sample gas cell and flange adapter with M8 screws). Not valid for flange adapter with M5 screws (0.5 bar).



NOTE:

- ▶ Observe local regulations with regard to pressure!
- ▶ Do not use the TRANSIC151LP for unstable gases (e.g., acetylene).

10.4.11 Options and accessories

Hydrophobic PTFE filter	Hydrophobic PTFE filter, average pore size 0.8 μm
Sample gas cell volumes	V: 0.280 l
Gas connections	Swagelok connection for Ø 6 mm gas tubes
T ₉₀ response time with 1 l/min gas sample flow rate	11 s
Weight	2.2 kg

11 Annex

11.1 Humidity Conversion Table

Humidity value (absolute) in g/m ³ H ₂ O		5	10	15	20	25	30	35	40	45	50	55	60	65	70	75	80	85	90	95	100	
T(°C)	(% r.h.)																					
-40	0	0	0	0	0	0	0	0	0	0	0	0	0	0	0	0	0	0	0	0	0	
-35	0	0	0	0	0	0	0	0	0	0	0	0	0	0	0	0	0	0	0	0	0	
-30	0	0	0	0	0	0	0	0	0	0	0	0	0	0	0	0	0	0	0	0	0	
-25	0	0	0	0	0	0	0	0	0	0	0	0	0	0	0	0	0	0	0	0	0	
-20	0	0	0	0	0	0	0	0	0	0	0	0	0	0	0	0	0	0	0	0	0	
-15	0	0	0	0	0	0	0	0	0	0	0	0	0	0	0	0	0	0	0	0	0	
-10	0	0	0	0	0	0	0	0	0	0	0	0	0	0	0	0	0	0	0	0	0	
-5	0	0	0	0	0	0	0	0	0	0	0	0	0	0	0	0	0	0	0	0	0	
0	0	0	0	0	0	0	0	0	0	0	0	0	0	0	0	0	0	0	0	0	0	
5	0	0	0	0	0	0	0	0	0	0	0	0	0	0	0	0	0	0	0	0	0	
10	0	0	0	0	0	0	0	0	0	0	0	0	0	0	0	0	0	0	0	0	0	
15	1	1	1	1	1	1	1	1	1	1	1	1	1	1	1	1	1	1	1	1	1	
20	1	2	3	3	4	4	5	6	7	8	9	10	10	11	12	13	14	15	16	16	17	
25	1	2	3	5	6	8	9	11	12	14	15	17	18	20	21	23	24	26	27	29	30	
30	2	3	5	8	10	12	14	18	20	23	26	28	31	33	36	38	41	43	46	49	51	
35	2	4	6	10	13	16	20	23	26	29	33	36	39	42	46	49	52	56	59	62	65	
40	3	5	8	10	13	16	20	23	26	29	33	36	39	42	46	49	52	56	59	62	65	
45	3	7	10	13	16	20	23	26	29	33	36	39	42	46	49	52	56	59	62	65	65	
50	4	8	12	17	21	25	29	33	37	41	46	50	54	58	62	66	70	75	79	83	83	
55	5	10	16	21	26	31	36	42	47	52	57	62	68	73	78	83	88	94	99	104	104	
60	6	13	19	26	32	39	45	52	58	65	71	78	84	91	97	104	110	117	123	130	130	
65	8	16	24	32	40	48	56	64	72	80	88	96	104	112	120	128	136	144	152	161	161	
70	10	20	30	39	49	59	69	79	89	99	108	118	128	138	148	158	168	177	187	197	197	
75	12	24	36	48	60	72	84	96	108	120	132	144	156	168	180	192	204	216	228	240	240	
80	15	29	44	58	73	87	102	116	131	146	160	175	189	204	218	233	247	262	277	291	291	

Table 6: Humidity Conversion Table

11.2 Influence of background gases on oxygen measurement

Gas	Coefficient	Unit
Acetone/propane (C ₃ H ₆ O)	-0.51	% of measured value / (vol% acetone)
Acetylene/ethine (C ₂ H ₂)	-0.47	% of measured value / (vol% acetylene)
Argon (Ar)	+0.12	% of measured value / (vol% argon)
Ethene (C ₂ H ₄)	-0.53	% of measured value / (vol% ethene)
Ethane (C ₂ H ₆)	-0.49	% of measured value / (vol% ethane)
Propane (C ₃ H ₈)	-0.75	% of measured value / (vol% propane)
Butane (C ₄ H ₁₀)	-1.02	% of measured value / (vol% butane)
1-Butene (C ₄ H ₈)	-0.89	% of measured value / (vol% 1-butene)
Isopentane/2-methyl butane (C ₅ H ₁₂)	-0.71	% of measured value / (vol% isopentane)
n-Hexane (C ₆ H ₁₄)	-0.90	% of measured value / (vol% n-hexane)
Methane (CH ₄)	-0.30	% of measured value / (vol% methane)
Carbon monoxide (CO)	-0.06	% of measured value / (vol% CO)
Carbon dioxide (CO ₂)	-0.15	% of measured value / (vol% CO ₂)
Cyclohexane (C ₆ H ₁₂)	-0.80	% of measured value / (vol% cyclohexane)
Dichloromethane (DCM) CH ₂ CL ₂	-0.38	% of measured value / (vol% dichloromethane)
Dimethyl ether (C ₂ H ₆ O)	-0.44	% of measured value / (vol% dimethyl ether)
Ethanol (C ₂ H ₆ O)	-0.32	% of measured value / (vol% ethanol)
Hydrogen (H ₂) ^[1]	-0.48	% of measured value / (vol% hydrogen)
Water (g/m ³)(H ₂ O)	-0.03	% of measured value / (g/m ³ water)
Helium (He)	+0.26	% of measured value / (vol% helium)
Methyl isobutyl ketone (C ₆ H ₁₂ O)	-0.88	% of measured value / (vol% methyl isobutyl ketone)
NOVEC71	-0.61	% of measured value / (vol% NOVEC71)
Propanol (C ₃ H ₈ O)	-0.41	% of measured value / (vol% propanol)
Tetrahydrofuran (C ₄ H ₈ O)	-0.58	% of measured value / (vol% tetrahydrofuran)
Toluene (C ₇ H ₈)	-0.74	% of measured value / (vol% toluene)
Xylene (C ₈ H ₁₀)	-0.62	% of measured value / (vol% C ₈ H ₁₀)

Table 7: Influence of background gases on oxygen measurement

[1] The TRANSIC151LP may only be used in zones in which either inflammable or explosive gases in groups I, IIA and IIB are present.

Example:

Gas mixture:	10% O ₂
(all concentrations in vol%)	20% CH ₄
	20% C ₂ H ₆
	50% N ₂
Relative error:	-0.3 x (20% CH ₄) + -0.49 x (20% C ₂ H ₆) = -15.8%
Absolute error:	10% O ₂ x -0.158 = -1.58% O ₂
TRANSIC100LP reading:	8.42%



- An up-to-date Table "Influence of background gases on oxygen measurement" can be requested from Endress+Hauser Service.
- If you have questions concerning further background gases not listed here, please contact Endress+Hauser Service.

11.4 Password

1010

8029872/ZUQ7/V1-3/2020-06

www.addresses.endress.com
