

Installation Instructions

Sight glasses of the shutter with seal

Source Container FQG74



1 Intended use

- A defective unit can only be replaced with a functioning unit of the same type.
- Use only original parts from Endress+Hauser.
- In the W@M Device Viewer, check if the spare part is suitable for the existing device.

 In some devices, an overview of spare parts is provided inside the device. If the spare part set is listed in the overview, it is not necessary to check the Device Viewer.

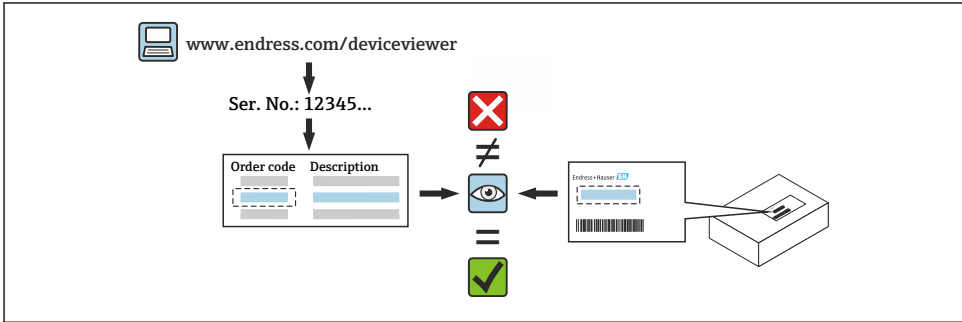

2 Symbols

2.1 Safety symbols

WARNING

This symbol alerts you to a potentially dangerous situation. Failure to avoid this situation can result in serious or fatal injury.

2.2 Radiation warning sign



Warning symbol for radioactive source according to ISO 7010

Warning sign for ionizing radiation

Identification of places and objects in and around which the presence of ionizing radiation is to be expected.



Warning symbol for highly radioactive source according to ISO21482

High radiation warning sign

- Warns of highly radioactive substances or ionizing radiation.
- Highly radioactive sources are marked separately on the source containers with the wording "highly radioactive source" and the supplemental warning symbol according to ISO21482.

2.3 Symbols for certain types of information and graphics

i Tip

Indicates additional information

1., **2.**, **3.**

Series of steps

3 Requirements for the personnel

⚠ WARNING

Danger from inadequately qualified personnel.

Physical damage and personal injury. Particularly as a consequence of incorrect handling.

- ▶ The requirements for personnel described below are mandatory for the plant operator.

Authorized repair personnel

Authorized repair personnel are

- ▶ qualified specialists having the appropriate qualification for the relevant function and task and meeting the relevant national requirements,
- ▶ authorized by the plant operator and
- ▶ familiar with national regulations.

4 Safety instructions

- Observe the Operating Instructions for the device.
- Comply with national regulations.
- Before removing the device: set the process to a safe state and purge the device of dangerous process substances.
- Risk of burns from hot surfaces! Before commencing work: allow the system and device to cool down to a touchable temperature.
- Modifications to the device are not permitted.
- Use original spare parts and accessories from Endress+Hauser only.

- Avoid ingress of foreign bodies, moisture or contaminants.
- If threads are damaged or defective, the device must be repaired.
- Observe the instructions for transporting and returning the device outlined in the Operating Instructions.

 For information on service and spare parts, contact your Endress+Hauser sales center.

5 Tool list

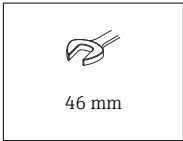

6 Removing the sight glass with seal

⚠ WARNING

Radiation damage and risk of injury from ionizing radiation when replacing a sight glass!

- ▶ Please follow the instructions on radiation protection contained in the Operating Instructions.
- ▶ Contact the relevant radiation safety officer for specific instructions.
- ▶ The source container must be secured in the "OFF" position.
- ▶ When working with radiation sources, avoid any unnecessary exposure to radiation.
- ▶ Keep all unavoidable radiation exposure to a minimum.
- ▶ Carry out all work from a protected position only.

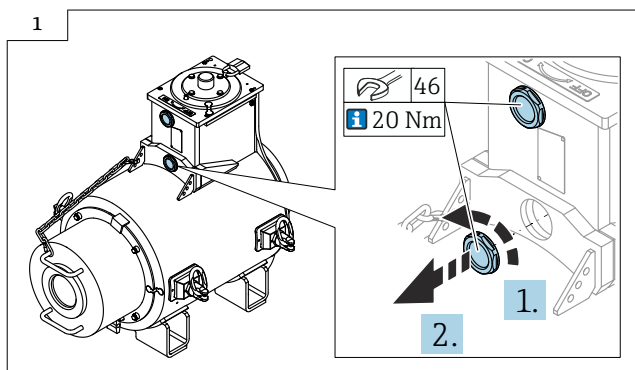

- ▶ **⚠ WARNING: IONIZING RADIATION!**
- ▶ Remove the sight glass with seal.
- ▶ **i** Pay attention to the tightening torque when installing.

7 Installation

7.1 General installation instructions

Installation is performed by following the removal procedure in reverse order.



71696069

www.addresses.endress.com
