

Safety Instructions

JT33 TDLAS gas analyzer

ATEX/IECEX/KCs: Zone 1

Safety instructions for the JT33 TDLAS gas analyzer in
explosion-hazardous areas

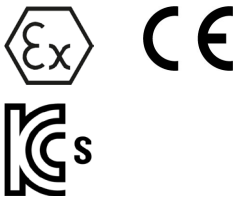

Table of Contents

1	Introduction	5
1.1	Intended equipment use.....	5
1.2	Associated documentation.....	5
1.3	Manufacturer's certificates.....	5
1.4	Manufacturer address	6
2	General safety	7
2.1	Warnings	7
2.2	Symbols.....	7
2.3	U.S. export compliance	7
2.4	Labels	8
2.5	Laser safety labels.....	9
2.6	Personnel qualifications.....	10
2.7	Equipment training.....	10
2.8	Potential risks affecting personnel	10
2.9	Specifications.....	11
2.10	Conditions of acceptability: ATEX/IECEX/KCs	14
3	Installation.....	16
3.1	Lifting and moving the analyzer	16
3.2	JT33 analyzer description.....	17
3.3	JT33 analyzer variants.....	17
3.4	Mounting the analyzer	19
3.5	Opening/closing the analyzer enclosure	23
3.6	Protective chassis and ground connections: JT33 analyzer.....	23
3.7	Protective chassis and ground connections: MAC.....	25
3.8	Electrical wiring requirements: JT33 analyzer.....	27
3.9	Electrical wiring requirements: MAC.....	28
3.10	Electrical circuit breakers.....	31
3.11	Connection values: signal circuits	31
3.12	IS flow switch connection requirements.....	34
3.13	Connecting the gas supply	34
3.14	Sample system heater	34
4	Equipment operation.....	35
4.1	Operating controls	35
4.2	Commissioning.....	35
4.3	Decommissioning.....	35
5	Maintenance and service	37
5.1	Cleaning and decontamination: JT33 analyzer.....	37
5.2	Cleaning and decontamination: MAC.....	37
5.3	Troubleshooting and repairs: JT33 analyzer.....	37

5.4 Troubleshooting and repairs: MAC 41

5.5 Spare parts 46

5.6 Service..... 46

1 Introduction

The Endress+Hauser JT33 TDLAS gas analyzer is a laser-based extractive analyzer for measuring gas concentration. The technology employed is tunable diode laser absorption spectroscopy (TDLAS). With an extractive measuring device, the gas sample is extracted from a vessel or pipeline and transported to the analyzer, which may be mounted up to 100 m (328 ft) from the sample tap point. Typical measurement ranges vary between 0 to 10 parts-per-million by volume (ppmv) and 0 to 500 ppmv H₂S.

The Measurement Accessory Controller (MAC) is part of certain models of the JT33 TDLAS gas analyzer. It is used for analyzer control of measurement accessories such as solenoid valves, heaters, and a vacuum pump.

Multiple variations of the analyzer are described in this manual. When a variant is not specified, the name JT33 analyzer is used.

1.1 Intended equipment use

The JT33 analyzer and MAC are intended for use as instructed in the documentation package provided with the equipment. This information should be read and referenced by anyone installing, operating, or having direct contact with the analyzer and MAC. Any use of the equipment in a manner not specified by Endress+Hauser could impair the protection provided by the equipment.

1.2 Associated documentation

Each analyzer shipped from the factory is packaged with documents for the model that was purchased. Most documentation is available on the USB flash drive provided with the shipment. This document is an integral part of the document package, which includes:

Part Number	Document Type	Description
BA02297C	Operating Instructions	A complete overview of the operations required to install, commission, and maintain the device
KA01655C	Brief Operating Instructions	Short instructions for standard installation and commissioning of the device
TI01722C	Technical Information	Technical data for the device with an overview of associated models available
GP01198C	Description of device parameters	Reference for parameters, providing a detailed explanation of each individual parameter of the operating menu
SD02192C	Special Documentation Heartbeat Technology	Reference for using the Heartbeat Technology function integrated in the measuring device
SD03032C	Special Documentation Web server	Reference for using the web server integrated in the measuring device
EX3100000056	Control drawing	Drawings and requirements for JT33 field interface connections

1.3 Manufacturer's certificates

The JT33 analyzer has been approved for use in hazardous areas according to the following certificates.

KTL certificate of conformity

KCs		
Certificate Number	Products	Rating
방호장치의무안전인증고시 (고용노동부고시제 2021-22 호)		
25-KA4BO-0207X	JT33 TDLAS spectrometer	Ex db ia [ia Ga] ib op is IIC T4 Gb
25-KA4BO-0205X	JT33 TDLAS gas analyzer (without sample conditioning system)	Ex db ia [ia Ga] ib op is IIC T4 Gb

Certificate Number	Products	Rating
25-KA4BO-0206X	JT33 TDLAS gas analyzer system	Ex db ia [ia Ga] ib op is IIC T3 Gb

ATEX / IECEx Certificate of conformity

Certificate Numbers	Products
IECEX CSAE 24.0001X CSANe 24ATEX1000X	JT33 TDLAS spectrometer JT33 TDLAS gas analyzer (without sample conditioning system) JT33 TDLAS gas analyzer system
Standards	
ATEX	IECEX
EN IEC 60079-0:2018 EN 60079-1:2014 + AC:2018-09 EN 60079-11:2012 EN 60079-28:2015 EN 60529:1992+A2:2013 IEC TS 60079-40:2015 Ed. 1	IEC 60079-0:2017 Ed. 7 IEC 60079-1:2014+COR1:2018 Ed. 7 IEC 60079-11:2011 Ed. 6 IEC 60079-28:2015 Ed. 2 IEC TS 60079-40:2015 Ed. 1

Area classification and markings by variant	
JT33 TDLAS spectrometer	Ex db ia [ia Ga] ib op is IIC T4 Gb Tambient = -20 °C to 60 °C (-4 °F to 140 °F)
JT33 TDLAS gas analyzer (without sample conditioning system)	Ex db ia [ia Ga] ib op is IIC T4 Gb Tambient = -20 °C to 60 °C (-4 °F to 140 °F)
JT33 TDLAS gas analyzer system	Ex db ia [ia Ga] ib op is IIC T3 Gb Tambient = -20 °C to 60 °C (-4 °F to 140 °F)
Ingress protection	Type 4X, IP66

1.4 Manufacturer address



Endress+Hauser

11027 Arrow Route
Rancho Cucamonga, CA 91730
United States





www.endress.com

2 General safety

2.1 Warnings

Structure of Information	Meaning
 WARNING Causes (/consequences) Consequences of noncompliance (if applicable) ▶ Corrective action	This symbol alerts you to a dangerous situation. Failure to avoid the dangerous situation can result in a fatal or serious injury.
 CAUTION Causes (/consequences) Consequences of noncompliance (if applicable) ▶ Corrective action	This symbol alerts you to a dangerous situation. Failure to avoid this situation can result in minor or more serious injuries.
NOTICE Cause/situation Consequences of noncompliance (if applicable) ▶ Action/note	This symbol alerts you to situations which may result in damage to property.

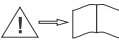
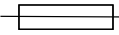
2.2 Symbols

Symbol	Description
	The Laser Radiation symbol is used to alert the user to the danger of exposure to hazardous visible laser radiation when using the system. The laser is a class 1 radiation product.
	The High Voltage symbol that alerts people to the presence of electric potential large enough to cause injury or damage. In certain industries, high voltage refers to voltage above a certain threshold. Equipment and conductors that carry high voltage warrant special safety requirements and procedures.
	Protective Earth (PE). A terminal which is bonded to conductive parts of equipment for safety purposes and is intended to be connected to an external protective earthing system.
	This symbol refers the user to the technical documentation for more information.
	The Fuse symbol is found on the Measurement Accessory Controller (MAC) printed circuit board adjacent to the fuse holder.
	The Ex mark signals to Authorities Having Jurisdiction and end-users in Europe that the product complies with the essential ATEX Directive for explosion protection.
	The CE Marking indicates conformity with health, safety, and environmental protection standards for products sold within the European Economic Area (EEA).

2.3 U.S. export compliance

The policy of Endress+Hauser is strict compliance with U.S. export control laws as detailed on the website of the [Bureau of Industry and Security](#) at the U.S. Department of Commerce.

2.4 Labels

2.4.1 Nameplates

Images of the nameplates for the JT33 analyzer and the Measurement Accessory Controller (MAC) are shown below.

Approvals and warnings are listed on these labels, along with other analyzer-specific information, in the blank areas shown below.

Warning: DO NOT OPEN IN AN EXPLOSIVE ATMOSPHERE is listed on all nameplates.

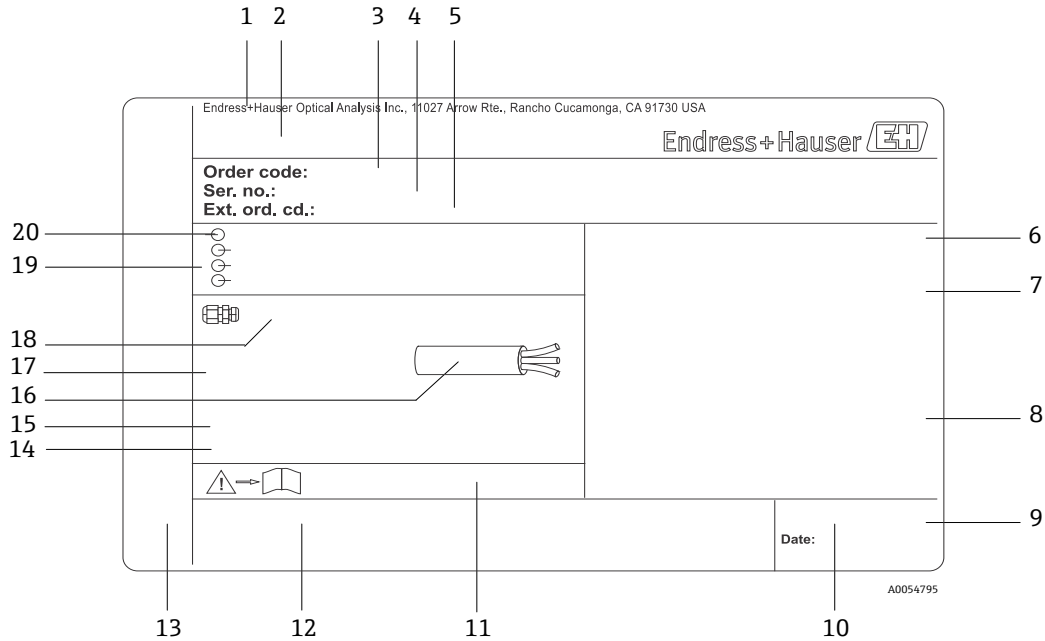

Figure 1. JT33 analyzer BA nameplate with approvals and warnings

#	Description
1	Manufacturing name and location
2	Product name
3	Order code
4	Serial number (SN)
5	Extended order code
6	Degree of protection
7	Space for approvals for use in hazardous areas, certificate numbers, and warnings
8	Electrical connection data: available inputs and outputs
9	2-D matrix code (serial number)
10	Manufacturing date: year-month

#	Description
11	Document number of safety-related supplementary documentation
12	Space for approval markings (e.g., CE mark)
13	Space for degree of protection of connection and electronics compartment when used in hazardous areas
14	Space for additional information (special products)
15	Permitted temperature range for cable
16	Permitted ambient temperature (Ta)
17	Information on cable gland
18	Cable entry
19	Available inputs and outputs, supply voltage
20	Electrical connection data: supply voltage

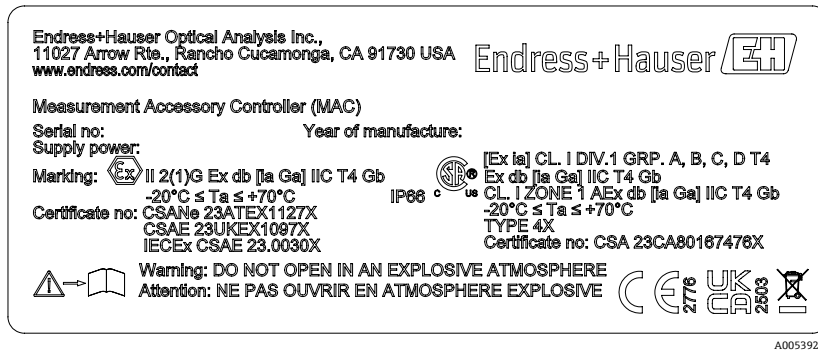

Figure 2. MAC nameplate with approvals and warnings

2.4.2 Controller

POWER
 Nicht unter Spannung offen
 Do not open when energized
 Ne pas ouvrir sous tension

Terminate power prior to accessing equipment to prevent damage to the analyzer.

Warning: DO NOT OPEN IN
 EXPLOSIVE ATMOSPHERE
 Attention: NE PAS OUVRIR EN
 ATMOSPHERE EXPLOSIVE

Use caution before opening the analyzer enclosure to avoid injury.

2.5 Laser safety labels

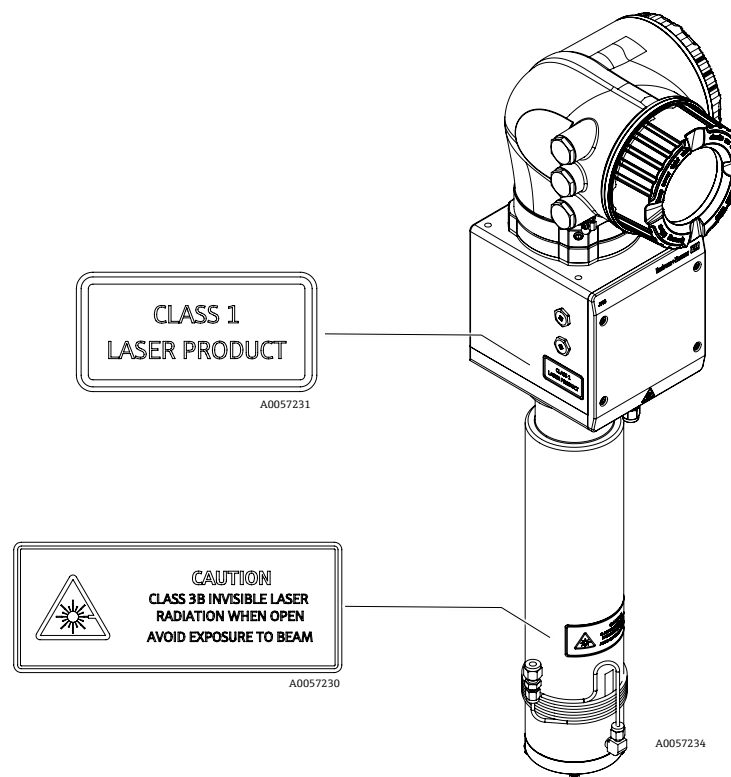

Figure 3. Location of laser safety labels

2.6 Personnel qualifications

Personnel shall meet the following conditions for mounting, electrical installation, commissioning, and maintenance of the device. This includes, but is not limited to:

- Suitably qualified for their role and the tasks they perform
- Understanding of the general principles of explosion protection methods
- Understand the general principles and types of protection and markings
- Understand the aspects of equipment design which affect the protection concept
- Understand the content of certificates and relevant parts of IEC 60079-14
- General understanding of inspection and maintenance requirements of IEC 60079-17
- Familiar with the techniques used in the selection and installation of equipment referenced in IEC 60079-14
- Understand the additional importance of permit to work systems and safe isolation in relation to explosion protection
- Familiar with national and local regulations and guidelines, such as ATEX/IECEX/KCs
- Familiar with lockout/tagout procedures, toxic gas monitoring protocols, and personal protective equipment (PPE) requirements

Personnel shall also be able to demonstrate competency in the:

- Use of documentation
- Production of documentation in inspection reports
- Practical skills necessary for the preparation and implementation of relevant concepts of protection
- Use and production of installation records

2.6.1 General

- Adhere to all warning labels to prevent damage to the unit.
- Do not operate the device outside the specified electrical, thermal, and mechanical parameters.
- Only use the device in media to which the wetted materials have sufficient durability.
- Modifications to the device can affect the explosion protection and must be carried out by staff authorized to perform such work by Endress+Hauser.
- Ensure foreign matter (solid, liquid, or gas) does not enter the MAC or controller enclosure during maintenance to preserve its pollution degree 2 rating.
- Only open the controller or MAC cover if the following conditions are met:
 - An explosive atmosphere is not present.
 - All device technical data is observed (see nameplate).
- In potentially explosive atmospheres:
 - Do not disconnect any electrical connections while the equipment is energized.
 - Do not open the connection compartment cover or MAC cover when energized or the area is known to be hazardous.
- Install the controller and MAC field wiring according to IEC 60079-14.
- Install the device according to the manufacturer's instructions and local regulations.

WARNING

Substitution of components is not permitted.

- ▶ Substitution of components may impair intrinsic safety.

2.7 Equipment training

Refer to local service providers for installation and operational training of the JT33 analyzer and MAC. Note that the MAC equipment only works in conjunction with the JT33 TDLAS spectrometer.

2.8 Potential risks affecting personnel

This section addresses the appropriate actions to undertake when faced with hazardous situations during or before service of the analyzer. It is not possible to list all potential hazards within this document. The user is responsible for identifying and mitigating any potential hazards present when servicing the analyzer.

NOTICE

- ▶ Technicians are expected to be trained and follow all safety protocols that have been established by the customer in accordance with the area hazard classification to service or operate the analyzer and MAC controller.
- ▶ This may include, but is not limited to, toxic and flammable gas monitoring protocols, lockout/tagout procedures, the use of PPE requirements, hot work permits and other precautions that address safety concerns related to the use and operation of process equipment located in hazardous areas.

2.8.1 Electrocutation hazard

⚠ WARNING

- ▶ Complete this action before performing any service that requires working near the main input power or disconnecting any wiring or other electrical components.

1. Shut off power at the main disconnect external to the analyzer.
2. Only use tools with a safety rating for protection against accidental contact with voltage up to 1000 V (IEC 900, ASTF-F1505-04, VDE 0682/201).

2.8.2 Laser safety

The JT33 spectrometer is a Class 1 laser product, which poses no threat to equipment operators. The laser internal to the analyzer controller is classified Class 1 and could cause eye damage if the beam is viewed directly.

⚠ WARNING

- ▶ Before servicing, shut off all power to the analyzer.

2.8.3 Electrostatic discharge: JT33 analyzer and MAC

The powder coating and the adhesive labels are nonconducting and may generate an ignition-capable level of electrostatic discharge under certain extreme conditions. The user should ensure that the equipment is not installed in a location where it may be subjected to external conditions, such as high-pressure steam, which might cause a buildup of electrostatic charges on nonconducting surfaces. To clean the equipment, use only a damp cloth.

2.8.4 Chemical compatibility

Never use vinyl acetate or acetone or other organic solvents to clean the analyzer housing or labels.

2.9 Specifications

2.9.1 Analyzer technical specifications

Electrical and communications: input voltages	
JT33 TDLAS spectrometer	AC 100 to 240 V tolerance $\pm 10\%$, 50/60 Hz, 10W ¹ DC 24 V tolerance $\pm 20\%$, 10W UM = AC 250 V
MAC	AC 100 to 240 V $\pm 10\%$, 50/60 Hz, 275W ¹ DC 24 V $\pm 10\%$, 67W UM = AC 250 V

Electrical and communications: output type	
JT33 TDLAS spectrometer	
Modbus RS485 or Modbus TCP over Ethernet (I/O1)	UN = DC 30 V UM = AC 250 V N = nominal M = maximum

¹ Transient over-voltages according to Over Voltage Category II.

Electrical and communications: output type	
JT33 TDLAS spectrometer	
Relay output (I/O2 and/or I/O3)	UN = DC 30 V UM = AC 250 V IN = DC 100 mA/AC 500 mA
Configurable input/output (I/O) Current 4-20 mA I/O passive/active (I/O2 and/or I/O3)	UN = DC 30 V UM = AC 250 V
Intrinsically safe (IS) output flow switch	Uo = Voc = ±5.88 V Io = Isc = 4.53 mA Po = 6.66 mW Co = Ca = 43 µF Lo = La = 1.74 H

Electrical and communications: output type	
MAC	
Intrinsically safe output RS485 to optical head electronics (Manufacturer connection)	ATEX/IECEX/KCs: J7 connector, Pin 1/Pin 2 w.r.t. enclosure earth Ui = Ui/Vmax = ±5.88 V Ii = Ii/Imax = -22.2 mA, resistively limited by a minimum resistance Rmin = 265 Ω Ci = 0 Li = 0 Uo = Uo/Voc = 5.36 V Io = Io/Isc = 39.7 mA (resistively limited) Po = 52.9 mW
	Pin 1 w.r.t Pin 2 Ui = Ui/Vmax = ±11.76 V Ci = 0 Li = 0 Uo = Uo/Voc = ±5.36 V Io = Io/Isc = ±10 mA (resistively limited) Po = 13.3 mW
Intrinsically safe output sample conditioning system (SCS) thermistor	J5 connector Ui/Vmax = 0 Uo = Voc = +5.88 V, -1.0 V Io = Io/Isc = 1.18 mA (resistively limited) Po = 1.78 mW Ci = 0 Li = 0
SCS heater output	UN = AC 100 to 240 V ±10 % UM = AC 250 V IN = AC 758 to 2000 mA
Output rating for solenoid valves	UN = DC 24 V UM = AC 250 V IN = 1A contact rating Psov = ≤ 42W

Application data	
Environmental temperature range: JT33 TDLAS spectrometer ²	Storage: -40 to 60 °C (-40 to 140 °F) Ambient (T _A): -20 to 60 °C (-4 to 140 °F)
Environmental temperature range: JT33 TDLAS gas analyzer (without sample conditioning system) ^{2, 3}	Storage: -40 to 60 °C (-40 to 140 °F) Ambient (T _A): -20 to 60 °C (-4 to 140 °F)
Environmental temperature range: JT33 TDLAS gas analyzer system ²	Storage: -40 to 60 °C (-40 to 140 °F) Ambient (T _A): -20 to 60 °C (-4 to 140 °F)
Environmental temperature range: MAC ^{2, 3}	Storage: -40 to 60 °C (-40 to 140 °F) Ambient (T _A): -20 to 70 °C (-4 to 158 °F)
Environmental relative humidity	80 % at temperatures up to 31 °C (88 °F), decreasing linearly to 50 % at 40 °C (104 °F)
Environment, pollution degree: JT33 TDLAS spectrometer	Rated Type 4X and IP66 for outdoor use and considered pollution degree 2 internally
Environment, pollution degree: MAC	Rated Type 4X and IP66 for indoor/outdoor use and considered pollution degree 2 internally
Altitude	Up to 2000 m (6562 ft)
Measurement ranges (H ₂ S)	0 to 10 ppmv 0 to 500 ppmv Other ranges available upon request
Sample inlet pressure (SCS)	207 to 310 kPaG (30 to 45 psig)
Validation inlet pressure	207 to 310 kPaG (30 to 45 psig)
Sample cell operating pressure range	Application dependent 800 to 1200 mbara (standard) 800 to 1700 mbara (optional)
Sample cell tested pressure range	-25 to 517 kPaG (-7.25 to 75 psig)
Factory relief valve set point	Approximately 345 kPaG (50 psig)
Operational temperature	-20 to 50 °C (-4 to 122 °F) -10 to 60 °C (14 to 140 °F)
Sample process temperature (T _p)	-20 to 60 °C (-4 to 140 °F)
Sample flow rate	2.5 to 3 slpm (5.30 to 6.36 scfh)
Bypass flow rate	0.5 to 2.0 slpm (1 to 4.24 scfh)
Process seal	Dual seal without annunciation
Primary process seal ^{4 1}	SCHOTT NG11 glass Sealant: Master Bond EP41S-5
Primary process seal ^{4 2}	Primary process seal 2 Material: alumina ceramic
Secondary process seal ⁴	ISEM interface module assembly

² Both the electronics and MAC power have to be on to ensure the cell is maintained at the target temperature.

³ For the JT33 TDLAS gas analyzer (without sample conditioning system) variant, the temperature inside the customer provided SCS enclosure shall not exceed 60 °C (140 °F).

⁴ See *JT33 analyzer seals* → .

2.9.2 JT33 analyzer seals

The optical head of the analyzer interfaces with the process medium through a window and pressure transducer in the cell tube assembly. The window and pressure transducer are the primary seals of the equipment. The ISEM interface module assembly is the analyzer's secondary seal, which separates the transmitter head from the optical head.

Although the JT33 analyzer contains other seals to prevent the migration of process medium into the electrical wiring system, if either of the primary seals fail, only the ISEM interface module assembly is considered a secondary seal.

All optical heads for JT33 analyzers were assessed as "Dual Seal without Annunciation" devices. Refer to the markings on the label for the maximum working pressures.

MAC enclosure entries require either a barrier gland or conduit seal, depending on the application, and shall be located within 127 mm (5 in) from the MAC enclosure.

For Class I Zone 1, installation seals are required within 51 mm (2 in) of the analyzer transmitter housing. If the JT33 analyzer includes a heated enclosure, a suitable equipment certified seal shall be installed within 127 mm (5 in) of the outer MAC enclosure wall.

2.10 Conditions of acceptability: ATEX/IECEX/KCs

- The flameproof joints of this equipment are other than the minimums specified in IEC 60079-1 and shall not be repaired by the user.
- When cable entry devices are provided by the end user for the MAC, these shall meet the requirements of IP66 following the tests of enclosures as defined in IEC 60079-0..
- The user shall ensure that the local ambient temperature of the MAC enclosure does not exceed 70 °C (158 °F) in the end application.
- The temperature of the equipment's transmitter can reach 67 °C (153 °F) in a 60 °C (140 °F) ambient at the cable entry and the branching point. This must be considered by the user when selecting field wiring and cable entry devices.
- The temperature of the MAC enclosure can reach 71.8 °C (161.2 °F) when 70 °C (158 °F) ambient at the cable entry. This must be considered by the user when selecting field wiring and cable entry devices. They shall be suitable for a temperature of at least 75 °C (167 °F).
- The equipment features a DC 24 V output for up to 7 solenoid valves on connector J6. The total load shall not exceed 42W.
- The AC version of the MAC may be connected to a suitable heater on J11 up to a power of 200W.
- The following connectors shall not be used: J2 cell thermistor, J3 pump, and J9 24 V cell heater.
- Adhesive labels and the powder coating of the equipment are nonconducting and may generate an ignition-capable level of electrostatic discharge under certain extreme conditions. The user should ensure that the equipment is not installed in a location where it may be subjected to external conditions, such as high-pressure steam, which may cause a buildup of electrostatic charges on these nonconducting surfaces. To clean the equipment, use only a damp cloth.

WARNING: POTENTIAL STATIC HAZARD. CLEAN ONLY WITH A WATER WETTED CLOTH.

- The JT33 TDLAS spectrometer is not capable of passing a 500 V r.m.s. dielectric strength test between the intrinsically safe flow switch connection circuits and enclosure according to Clause 6.3.13 of IEC 60079-11:2011. This shall be taken into account during equipment installation.
- The Measurement Accuracy Controller (MAC) is not capable of passing a 500 V r.m.s. dielectric strength test between the intrinsically safe thermistor connection circuits and enclosure according to Clause 6.3.13 of IEC 60079-11:2011. This shall be taken into account during equipment installation.
- The installation of the JT33 TDLAS gas analyzer (without sample conditioning system) shall incorporate an electrical bonding conductor connected between the JT33 TDLAS spectrometer optical head enclosure and the panel on which the MAC is installed.
- Any connection to the JT33 TDLAS spectrometer intrinsically safe flow switch connector shall be made via a certified M12 x 1.5 Ex be IIC IP66 rated certified cable gland suitable for a temperature range of -20 to 75 °C (-4 to 167 °F), that shall be fitted in an optical head enclosure entry. The connection is made to a printed circuit board mounted 4-pin black connector J6 via a mating free Molex connector (part number 502351-0401) fitted with Molex crimp contacts (part number 5600850101). Access to the connection is gained by removal of the optical head enclosure which shall be refitted using a fastener torque of 2 Nm (17.7 in-lbf).
- Any connection to the MAC intrinsically safe thermistor printed circuit board mounted connector J5 SCS THRM shall be made via a mating free TE Connectivity AMP receptacle (part number 6-179228-2) fitted with TE Connectivity AMP crimp contacts (part number 179227-4).
- When J5 is used as a field wiring connection, the installer shall use cable with an inner core minimum radial insulation thickness of ≥ 0.5 mm (0.02 in). The installer shall also use the appropriate crimp supplied by the manufacturer.
- The equipment shall be supplied from an Overvoltage Category II source only.
- The JT33 TDLAS gas analyzer (without sample conditioning system) shall be installed in an enclosure that is suitable for the environment of use and that provides protection against mechanical impact. The user shall ensure that the surrounding temperature of the optical head does not exceed 60 °C (140 °F) and that the surrounding temperature of the MAC does not exceed 70 °C (158 °F).

- To ensure the degree of protection is maintained, the user shall ensure that the cover seal of the G3xx enclosure (transmitter) is flat with no bends in the seal surface before securing the cover. Seals that are not flat are to be replaced.
- This equipment is intended to operate at constant pressure and has not been assessed for the effects of persistent fluctuations of pressure within the operating range. Therefore, the user shall ensure that the pressure fluctuation within the sample cell tube of the equipment does not routinely exceed 5 lbf/in² (5 psi).
- An optional stainless steel label tag which may be present on the transmitters of this equipment is not bonded to earth. The maximum average capacitance of the tag determined by measurement is maximum 30 pF. This shall be considered by the user to determine suitability of the equipment in a specific application.
- The maximum working pressure (MWP) of the equipment is listed as 800 to 1200 mbara or 800 to 1700 mbara (model-dependent). This is the pressure range at which the manufacturer has determined the equipment can operate. However, the equipment was assessed to withstand a pressure of 75 lbf/in² (75 psi) against CSA C22.2 No 60079-40:20 and UL 122701 (2021).

3 Installation

⚠ CAUTION

The safety of the analyzer is the responsibility of the installer and the organization they represent.

- ▶ Use appropriate protective safety equipment as recommended by local safety codes and practices, such as hard hat, steel-toe shoes, or gloves. Exercise caution, particularly when installing equipment at a height (≥ 1 m or ≥ 3.3 ft above ground).

3.1 Lifting and moving the analyzer

The JT33 analyzer weighs up to 102.5 kg (226 lb) and is shipped in a wooden crate. Because of the size and weight, Endress+Hauser recommends the following process for lifting and moving the analyzer for installation.

Equipment/materials

- Crane or forklift with lifting hook
- Dolly or scissor jack
- Four 25 mm (1 in) wide endless ratchet straps rated for a minimum of 500 kg (1100 lb) each
- Cloths

NOTICE

Overtightening the ratchets on the horizontal straps may damage the enclosure.

- ▶ The horizontal straps must be tight enough to hold the vertical straps in position, but not too tight.
- ▶ Place cloths between the ratchet points and the enclosure to prevent scratches.

1. Move the crate as close to the final installation location as possible.
2. With the analyzer still in the crate, route 2 of the ratchet straps vertically on each side of the analyzer. Ensure the straps under the enclosure align outside of the bottom mounting tabs as shown in the figure below.
3. Bring both straps together at the top of the analyzer, allowing enough slack to pass the lifting hook through the straps.
4. Install the third strap horizontally toward the bottom of the enclosure by weaving it over and under the vertical straps. Install the fourth strap horizontally toward the top of the enclosure by weaving it over and under the vertical straps in the opposite pattern from the third strap.
5. Remove the analyzer from the crate using the crane or forklift.
6. Place the analyzer on a dolly or scissor jack and remove the straps to finish the installation.

If necessary, the installation can be completed using the crane or forklift and the ratchet straps.

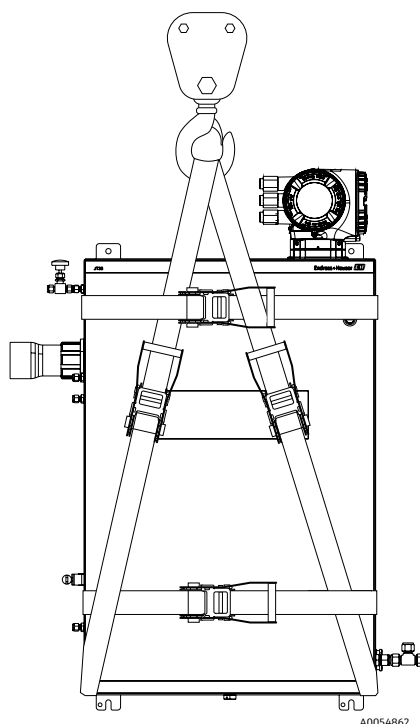

Figure 4. JT33 analyzer with ratchet straps for lifting and moving

3.2 JT33 analyzer description

The optical head is mounted on top of the cell and contains the laser, optical detector, and a thermoelectric cooler to control the laser temperature. The optical head also contains the optical head electronics, which are directly connected to the optoelectronics in the optical head. The optical head electronics board also communicates with the electronics assembly and the MAC.

The electronics assembly is mounted on top of the optical head within a flameproof enclosure. The electronics assembly, powered by an AC 100 to 240 V $\pm 10\%$ or DC 19.2 to 28.8 V source, contains the sensor electronics. The sensor electronics connect to the optical head with the RS232 protocol through a 10-pin ribbon cable assembly.

The sensor electronics and the optical head electronics operate on a DC 30 V supply using the same 10-pin ribbon cable. The sensor electronics generate the laser drive signal that is sent through the optical head electronics and to the laser in the optical head. Signals from the detectors are amplified by the optical head electronics and sent to the sensor electronics where they are digitized. The sensor electronics process the digital data and send the gas concentration measurements to the electronics display and I/O modules.

The MAC microcontroller firmware operates digital temperature controls. It receives directions from the optical head electronics to set temperature targets and report the status of the temperature control. There is one heater assigned to the MAC which is switched on and off. One sensing thermistor of the MAC is used to measure the ambient temperature inside the heated enclosure.

The electronics assembly displays the concentration measurement on an LCD display and has a through-the glass 3-button keypad interface for user input. The flameproof enclosure of the electronics assembly also houses the electrical terminals for field wiring connections. The JT33 analyzer is offered with various analogue and digital outputs which may be used in automation or communication systems to deliver its measurements and applicable diagnostic messages and alarms to remote devices.

Additionally, the electronics assembly has a service port which allows interaction with the JT33 analyzer on a standard web browser using a laptop or tablet. This connection is used by the manufacturer or trained personnel for test, repair, or overhaul of the equipment under nonhazardous conditions with no explosive atmosphere.

3.3 JT33 analyzer variants

The JT33 analyzer may be configured without sample conditioning on a panel or heated enclosure. An optional IP66/Type 4X rated enclosure may be included, which surrounds the cell tube, MAC, and SCS. The certified variants are described below.

NOTICE

The JT33 analyzer variants described in sections 3.3.1 and 3.3.2 shall be installed in an enclosure suitable for protection against mechanical impact.

- ▶ When installed in an enclosure, the ambient temperature of 70 °C (158 °F) for the MAC assembly shall be ensured and an additional evaluation may be required to verify the suitability, such as local ambient temperature or protective earth (PE) connection.

3.3.1 JT33 TDLAS spectrometer

The JT33 TDLAS spectrometer variant consists of an Ex d flameproof electronics compartment, intrinsically safe optical head, and a cell tube and mirror assembly.

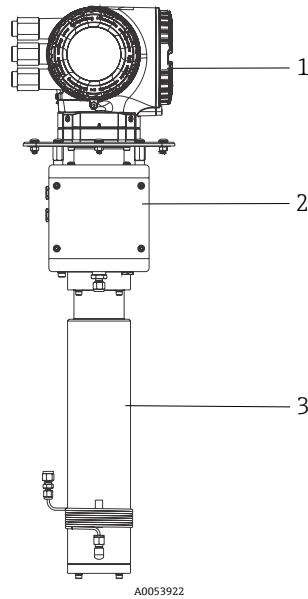

Figure 5. JT33 TDLAS spectrometer variant

#	Description
1	Electronics compartment
2	Optical head
3	Cell tube and mirror assembly

3.3.2 JT33 TDLAS gas analyzer (without sample conditioning system)

The JT33 TDLAS gas analyzer (without sample conditioning system) variant is configured with precertified equipment on a panel for customers who need to integrate a panel version into their own SCS. The panel is assembled with 2 or 3 solenoid valves, the pressure regulator, scrubber, and MAC. As described above, the MAC is linked with the JT33 TDLAS spectrometer by a serial cable to receive commands to energize solenoid valves which divert sample gas to flow through the scrubber before entering the cell tube. A pressure regulator is located upstream of the cell tube to ensure it does not operate above 103 kPa (14.9 psig).

CAUTION

The temperature inside the SCS enclosure provided by the customer shall not exceed 60 °C (140 °F).

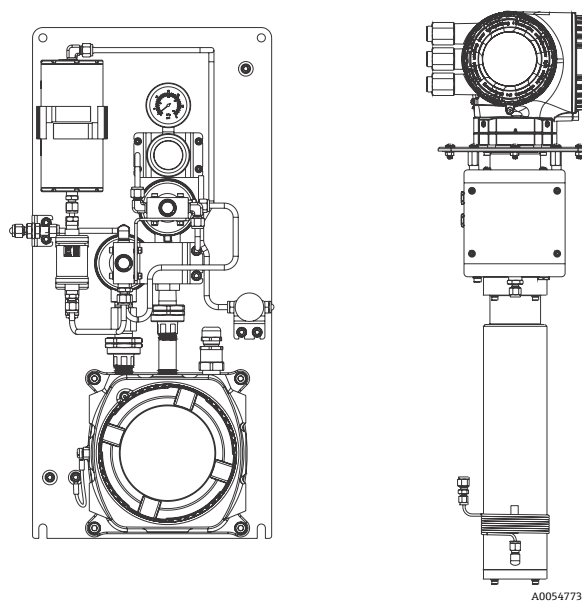

Figure 6. JT33 TDLAS gas analyzer (without sample conditioning system) variant

3.3.3 JT33 TDLAS gas analyzer system

The JT33 TDLAS gas analyzer system is a turnkey assembly configured with precertified equipment, including the heater, solenoid valves, scrubber, filter, isolation valves, enclosure and SCS. The SCS allows more precise control of the sample gas before it flows through the spectrometer.

The JT33 TDLAS gas analyzer system is comprised of a sample cell, intrinsically safe optical head, and an electronics assembly platform within a precertified flameproof enclosure. The cell is a sealed tube through which the gas mixture flows. The cell has a gas inlet and a gas outlet. On one end of the tube is a window through which a beam of infrared laser light travels, which in turn reflects on internal mirrors. In this arrangement, the gas mixture does not contact the laser or any other optoelectronics. Pressure, and in some cases temperature sensors, are employed in the cell assembly to compensate for the effects of pressure and temperature changes in the gas.

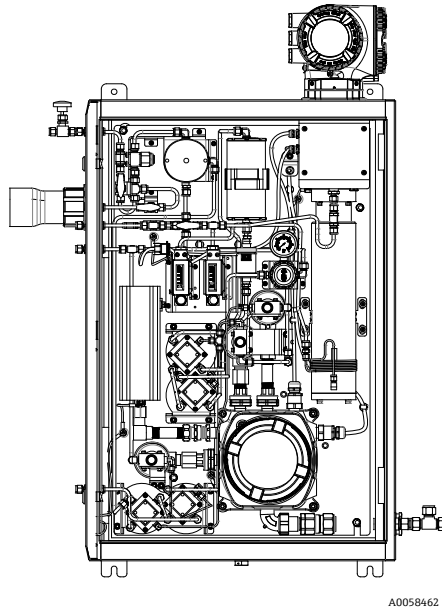

Figure 7. JT33 TDLAS gas analyzer system (IECEX)

3.4 Mounting the analyzer

Mounting options for the JT33 analyzer are based on the variant selected and whether the spectrometer is mounted in an enclosure with a plate or mounted on a panel.

When mounting the analyzer, be sure to position the instrument so that it is not difficult to operate adjacent devices. Refer to the layout diagrams for mounting dimensions and additional information in the Operating Instructions.

NOTICE

The JT33 analyzer is designed for operation within the specified ambient temperature range. Intense sun exposure in some areas may impact the temperature inside the analyzer controller.

- ▶ Installing a sunshade or canopy over the analyzer for outdoor installations in cases where the rated temperature range could be exceeded is recommended.

General notes for JT33 analyzer installations

- Install the ground connection located on the bottom of the controller to the supplied panel or to a chassis ground after mounted.
- Install the ground connection located on the bottom left of the MAC enclosure to the supplied panel or to a chassis ground after mounted.
- All accessories, such as glands, conduit seals, type A plugs, unions, elbows, and line bushings used on the analyzer shall comply with IEC/EN 60079-0 standards and provide a minimum ingress protection of IP66.
- It is the customer's responsibility to provide branch circuit protection for spectrometer mains. The maximum branch circuit rating is 10A. This circuit protection shall be part of the field installation and shall be a switch or a breaker. Its location must be visible, within reach, and marked as the disconnecting device of the equipment.
- It is the customer's responsibility to provide branch circuit protection for MAC mains. The maximum branch circuit rating is 20A. This circuit protection shall be part of the field installation and shall be a switch or a breaker. Its location must be visible, within reach and marked as the disconnecting device of the equipment.
- The equipment is not capable of passing a 500 V r.m.s. dielectric strength test between its intrinsically safe circuits and enclosure according to Clause 6.3.13 of IEC 60079-11:2011. This shall be taken into account during equipment installation.

3.4.1 Enclosure mounting the JT33 spectrometer

For users installing the JT33 analyzer within their own enclosure, the JT33 analyzer should be installed vertically with the analyzer controller exposed to the exterior of the enclosure.

Hardware supplied

- Machine screws and nuts for analyzer mounting
- O-ring for analyzer seal

To mount the JT33 analyzer

1. Refer to the enclosure mounting dimensions below to provide a proper cutout in the user-supplied enclosure.

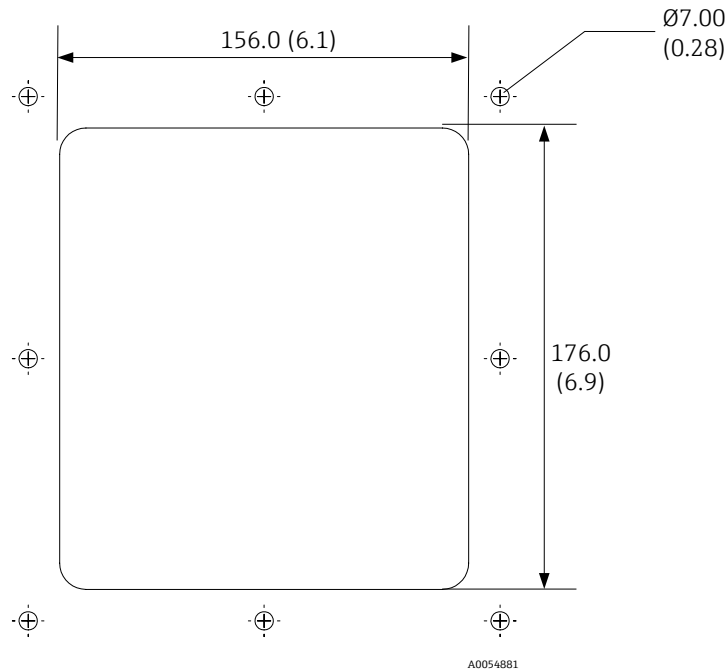

Figure 8. Enclosure mounting cutout. Dimensions: mm (in)

2. Lower the spectrometer through the enclosure hole so the plate aligns with the gasket. Ensure the o-ring is still seated in its groove before lowering the spectrometer into the enclosure.
3. Secure the spectrometer in place with eight M6 x 1.0 screws and corresponding nuts. Tighten to a minimum 13 Nm (115 lb-in).

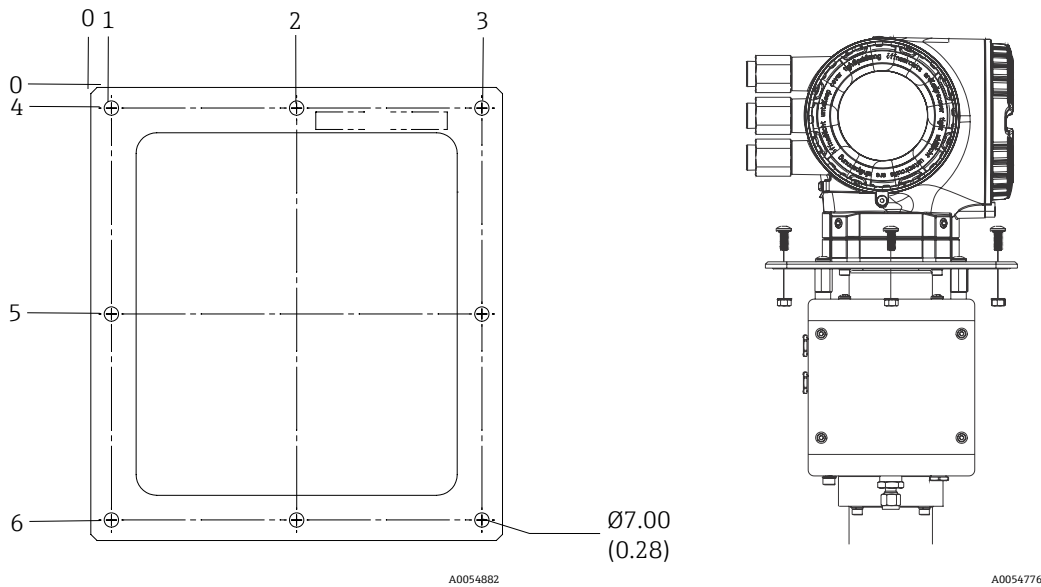

Figure 9. Enclosure mounting plate and hardware. Engineering units: mm (in)

Distance to hole. Engineering units: mm (in)					
From corner 0			From corner 0		
1	2	3	4	5	6
10.0 (0.39)	100.0 (3.94)	190.0 (7.48)	10.0 (0.39)	110.0 (4.33)	210.0 (8.27)

3.4.2 Panel mounting the JT33 spectrometer

For users installing the JT33 analyzer on a panel, refer to the panel mounting dimensions below. M8 panel mounting studs are not supplied.

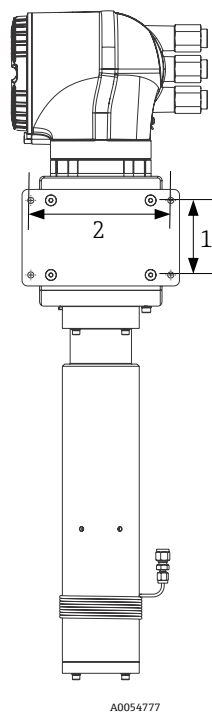

Figure 10. Panel mounting dimensions

#	Panel	Distance between holes mm (in)
1	Height	85.0 (3.3)
2	Width	160.0 (6.3)

3.4.3 Mounting the differential panel in an enclosure

NOTICE

- ▶ Hardware used for mounting the differential panel must be able to support 4 times the weight of the panel. A fully populated differential panel weighs approximately 18 kg (40 lb).
- ▶ The differential panel must be installed in a heated enclosure.

NOTICE

- ▶ MAC enclosure entries require either a barrier gland or conduit seal, depending on the application, and shall be located within 127 mm (5 in) of the MAC enclosure.
- ▶ The customer is required to install/pot barrier gland or conduit seal in the field according to the manufacturer’s specifications for the gland or seals. Potting material needs to be suitable for ambient temperature of at least 75 °C (167 °F).

General notes for differential panel installation

- Field power entry is located on the bottom of the MAC enclosure.
- Install the ground connection located on the bottom left of the panel to a chassis ground point.
- All accessories, such as glands, conduit seals, type A plugs, unions, elbows, and line bushings used on the MAC shall comply with IEC/EN 60079-0 standards and provide a minimum ingress protection of IP66.
- It is the customer’s responsibility to provide branch circuit protection for mains. The maximum branch circuit rating is 20A. This circuit protection shall be part of the field installation and shall be a switch or a breaker. Its location must be visible, within reach, and marked as the disconnecting device of the equipment.
- The equipment is not capable of passing a 500 V r.m.s. dielectric strength test between its intrinsically safe circuits and enclosure according to Clause 6.3.13 of IEC 60079-11:2011. This shall be taken into account during equipment installation.

To install the differential panel in the enclosure

NOTICE

- ▶ The differential panel must be installed in a heated enclosure.
1. Refer to the panel dimensions shown below to determine stud location. 10 mm diameter clearance holes are provided.
 2. Install the panel onto studs and attach with the customer-supplied M8 hardware.

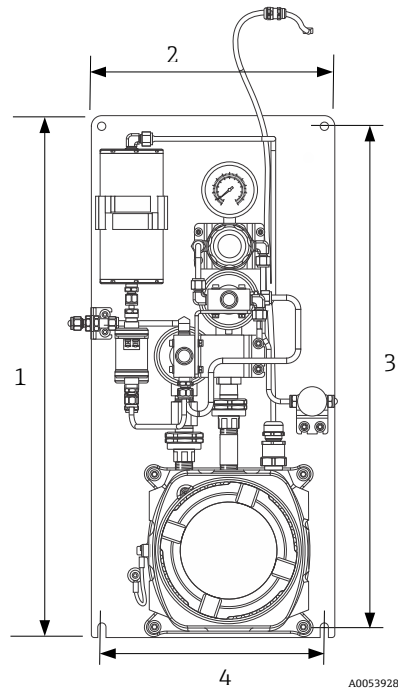

Figure 11. JT33 differential panel

#	Panel	Total measurement mm (in)	#	Distance between holes mm (in)
1	Height	628.7 (24.75)	3	603.25 (23.75)
2	Width	294.3 (11.59)	4	268.90 (10.59)

3.4.4 Wall mounting the JT33 TDLAS gas analyzer system

Hardware required (not supplied)

- Mounting hardware
- Spring nuts, if mounting on Unistrut
- Machine screws and nuts to fit the size of the mounting hole

NOTICE

- ▶ Hardware used for mounting the JT33 TDLAS gas analyzer system must be able to support 4 times the weight of the instrument, approximately 88.9 kg (196 lb) to 102.5 kg (226 lb), depending on the configuration.

To install the enclosure

1. Install the bottom 2 mounting bolts to the mounting frame or wall. Do not fully tighten the bolts. Leave an approximately 10 mm (0.4 in) gap to slide the analyzer mounting tabs onto the bottom bolts.
2. Safely lift the analyzer using the appropriate installation equipment. Refer to *Lifting and moving the analyzer* → .
3. Install the analyzer onto the bottom bolts and slide the slotted bottom mounting tabs over the bolts. Continue to support the weight of the analyzer with the equipment.



Figure 12. Slotted bottom mounting tabs of enclosure

4. Tilt the analyzer towards the mounting frame or wall to align and secure the 2 top bolts.



Figure 13. Top mounting tabs of enclosure

5. Tighten all 4 bolts and then remove the installation equipment.

3.5 Opening/closing the analyzer enclosure

WARNING

Hazardous voltage and risk of electric shock.

- ▶ Failure to properly ground the analyzer may create a high-voltage shock hazard.

3.6 Protective chassis and ground connections: JT33 analyzer

Before connecting any electrical signal or power, the protective and chassis grounds must be connected.

- Protective and chassis grounds must be of equal or greater size than any other current-carrying conductors, including the heater located in the SCS.
- Protective and chassis grounds to remain connected until all other wiring is removed.
- Protective grounding wire current carrying capacity must be at minimum the same as the main supply.
- Equipotential bonding connection must be at least 6 mm² (10 AWG).

3.6.1 Protective ground cable

- Analyzer: 2.1 mm² (14 AWG)
- Enclosure: 6 mm² (10 AWG)

The grounding impedance must be less than 1 Ω.

3.6.2 Electrical connections

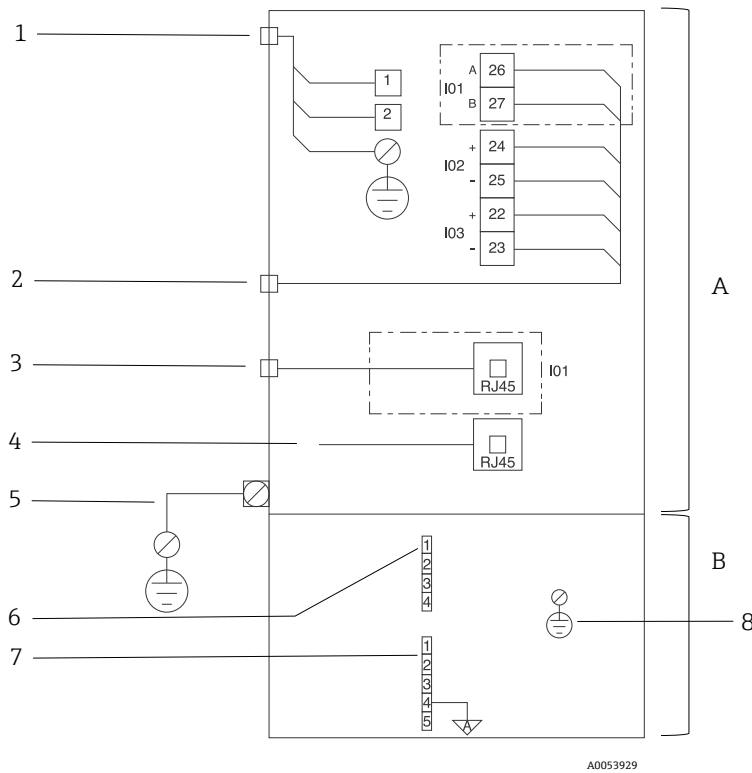

Figure 14. JT33 analyzer electrical connections

#	Description
JT33 controller (A)	
1	AC 100 to 240 V ± 10 %; DC 24 V ± 20 % 1 = line; 2 = neutral Wire is 14 gauge or larger for ground connection (for line, neutral and ground). Cross section of the cable is ≥ 2.1 mm ² .
2	Data ports I/O options: <ul style="list-style-type: none"> ▪ Modbus RTU ▪ Outputs: Current, Status, Relay ▪ Inputs: Current, Status Terminals 26 and 27 are used for Modbus RTU (RS485) only.
3	Alternative data port 10/100 Ethernet (optional), network option Modbus TCP Terminals 26 and 27 are replaced by an RJ45 connector for Modbus TCP.
4	Service port Internal connection is accessible only temporarily by trained personnel for test, repair, or overhaul of the equipment, and only if the area where the equipment is installed is known to be nonhazardous.
5	External ground lug Must be 10 gauge or larger. Cross section of the cable is ≥ 6 mm ² .

#	Description
Optical head (B)	
6	Flow switch connection (1 to 4) = connector J6. See drawing EX310000056. 1 = flow switch line 2 = analog ground 3 = no connection 4 = no connection
7	RS485 MAC communication lines (1 to 5) = connector J7. See drawing EX310000056. Connector J7 is for Endress+Hauser factory connection only. Do not use for installation or customer connection. 1 = negative intrinsically safe line 2 = positive intrinsically safe line 3 = no connection 4 = connection to the analog ground on the optical head enclosure (OHE) and to the RS485 harness shielding 5 = no connection
8	Internal ground to optical head cover

3.7 Protective chassis and ground connections: MAC

Before connecting any electrical signal or power, the chassis ground must be connected to the MAC.

- Equipotential bonding connection must be at least 2.5 mm² (14 AWG), so it is equal or greater than any other current-carrying conductors, including the heater located in the SCS.
- Protective earth (PE) ground is to remain connected until all other wiring is removed.
- Protective grounding wire current carrying capacity must be at minimum the same as the main supply.

3.7.1 Hardware provided

The following hardware is provided with the MAC enclosure to ensure an adequate ground bond:

- 2.5 mm² (14 AWG) ground cable with 14 to 18 AWG ring terminals with a 6.35 mm (¼") through-hole
- Zinc-plated M6 lock washer
- Pan head M6 x 1.0-15L zinc-plated screw

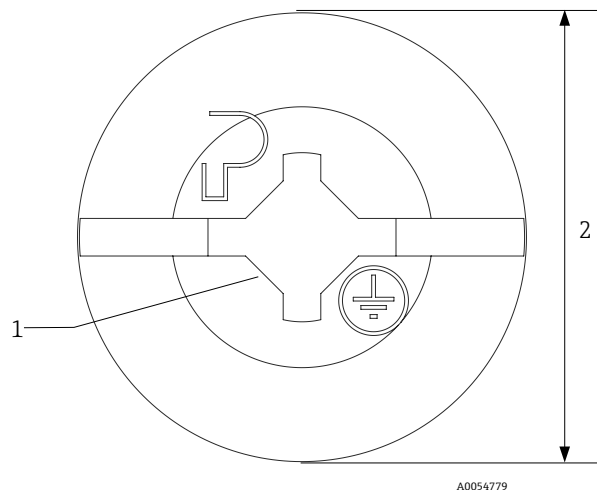

Figure 15. MAC enclosure ground screw

#	Description
1	Combination slotted #3 Phillips pan head
2	Ø11.94 mm (0.47 in) maximum

3.8 Electrical wiring requirements: JT33 analyzer

NOTICE

The installer is responsible for complying with all local installation codes.

- ▶ Field wiring (power and signal) shall be accomplished using wiring methods approved for hazardous locations as per the IEC 60079-14.
- ▶ Use copper conductors only.
- ▶ For models of the JT33 analyzer with SCS mounted within an enclosure, the inner sheath of the supply cable for the heater circuit shall be sheathed with thermoplastic, thermosetting, or elastometric material. It shall be circular and compact. Any bedding or sheath shall be extruded. Fillers, if any, shall be nonhygroscopic.
- ▶ The minimum length of the cable shall exceed 3 meters.

3.8.1 Wire temperature rating and terminal torque

- Temperature rating: -40 to 105 °C (-40 to 221 °F)
- Terminal block screw torque: 0.5 to 0.6 Nm (4.4 to 5.3 in-lbf)

3.8.2 Cable type

The standard ANSI/TIA/EIA-568-B.2 Annex specifies CAT5 as the minimum used for Ethernet/IP. CAT5e and CAT 6 are recommended.

3.8.3 Cable entries

After installing all interconnecting wiring or cabling, make sure any remaining conduit or cable entries are plugged with certified accessories according to the intended use of the product.

Thread lubricant must be applied on all conduit hub threaded connections. Using Syntheso Glep1 or equivalent lubricant on all conduit screw thread is recommended.

NOTICE

- ▶ Conduit seals and glands specific to the application shall be used where appropriate in compliance with local regulations.

3.8.4 Threaded entries

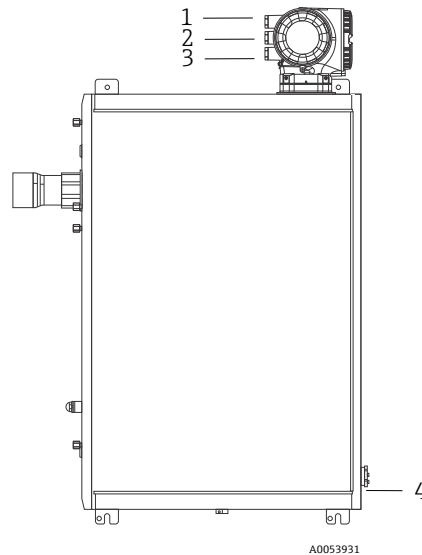

Figure 18. Threaded entries on ATEX (left) JT33 analyzer assemblies

Cable Entry	Description	ATEX, IECEx
1	Controller power	Female M20 x 1.5
2	Modbus power	Female M20 x 1.5
3	2 Configurable I/O	Female M20 x 1.5
4	MAC power	Male M25 x 1.5

Thread dimensions for the panel configuration are the same as shown for the enclosed sample system above.

3.9 Electrical wiring requirements: MAC

NOTICE

The installer is responsible for complying with all local installation codes.

- ▶ Field wiring (power) shall be accomplished using wiring methods approved for hazardous locations as per IEC 60079-14.
- ▶ Use copper conductors only.
- ▶ The total power consumption when the MAC assembly is operating on an AC voltage source shall not exceed 275W.
- ▶ The total power consumption when the MAC assembly is operating on a DC voltage source shall not exceed 67W.

3.9.1 Temperature rating and tightening torque

- The surface temperature of cables shall not exceed the temperature class for the installation.
- Cables, cable glands and conductors in conduit shall be rated 20 °C (68 °F) above service temperature, 75 °C (167 °F).
- Tightening torque: 0.5 to 0.6 Nm (4.4 to 5.3 in-lbf)

3.9.2 Cable type

Cables appropriate for installation in a hazardous location shall be one of the following types:

- Sheathed with thermoplastic, thermosetting, or elastomeric material. They shall be circular and compact. Any bedding or sheath shall be extruded. Fillers, if any, shall be nonhygroscopic.
- Mineral insulated metal sheathed.

Cables shall comply with IEC 60332-1-2 or IEC 60332-3-22 standard requirements.

Cables with low tensile strength sheaths, commonly known as “easy tear” cables, shall not be used in hazardous areas unless installed in conduit.

3.9.3 Glands and seals

NOTICE

- ▶ MAC enclosure entries require either a barrier gland or conduit seal, depending on the application, and shall be located within 127 mm (5 in) of the MAC enclosure.
- ▶ The customer is required to install/pot barrier gland or conduit seal in the field according to the manufacturer's specifications for the gland or seals. Potting material needs to be suitable for ambient temperature of at least 70 °C (158 °F).

Termination fittings, such as cable glands and conduit seals, in all hazardous areas shall be compatible with the degree of protection and the explosion protection provided by the enclosure they enter.

3.9.4 Cable entries

The MAC enclosure was designed to support 10 entry points. Each entry thread type and size is identified below, as well as the installation orientation. When installed as shown, the 3/4 MNPT power input entry faces the bottom.

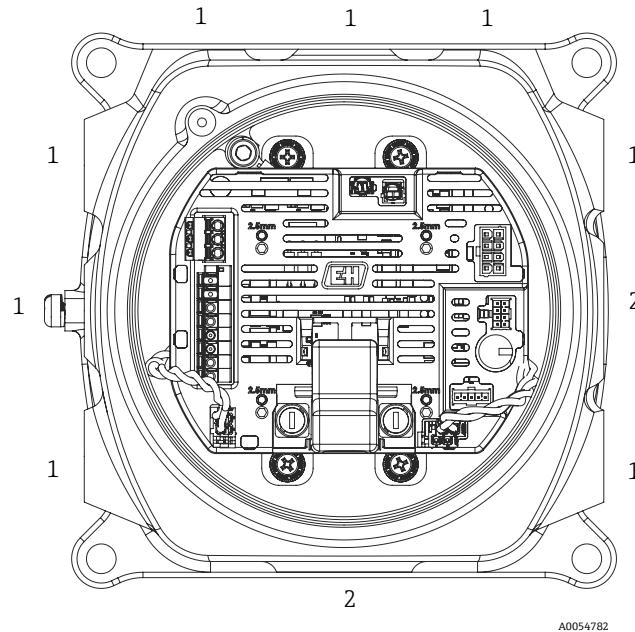

Figure 19. MAC enclosure entry point thread sizes

#	Description
1	½" FNPT
2	¾" FNPT

3.9.5 IS and non-IS interfaces

The MAC certified equipment, consisting of a single printed circuit board assembly and power supply (depending on voltage source), resides in an Ex d enclosure. It is powered independently of the ISEM and offers the capability for some intrinsically safe (IS) and non-intrinsically safe inputs and outputs.

One intrinsically safe interface is the SCS thermistor interface, which is connected by cable to an external thermistor outside the MAC enclosure. The SCS thermistor plugs directly into the J5 PCB connector using a preassembled harness supplied by the manufacturer. The receptacle on the end of the thermistor harness is a 2-position component with a maximum current rating of 4A. The other intrinsically safe interface is the OHE RS485 interface.

The non-intrinsically safe inputs and outputs include external power input, which may be a source of 24 V power obtained either from an AC mains to DC 24 V power converter module, or from a 24 V source from the customer power connection.

There are also non-intrinsically safe DC 24 V outputs available with capability to power up to 7 solenoid valves (not to exceed 42.0W total). Additionally, there are versions of the equipment with AC 100, 120, 230, or 240 V output, depending on the supply voltage, to power an SCS heater up to a maximum of 200W. The SCS heater is only present in systems when AC mains power can be provided for the heater. AC mains power for the heater is connected directly to the MAC board.

3.9.6 Electrical connections

The MAC can be powered with an alternating or direct current configuration. Power source wiring connects to J12 in the MAC through a 12A PCB connector supplied with the equipment. The connector accommodates wire size up to 2.5 mm² (14 AWG). Ferrules with plastic sleeves are used on the stripped wire ends. The required tightening torque is between 0.5 and 0.6 Nm (4.4 to 5.3 in-lbf).

The MAC supports the following application-dependent accessories and will have other inputs and outputs available in the future.

- J11: AC heater output
- J6: solenoid valves output
- J5: SCS thermistor input

The AC heater is wired using the J11 PCB connector supplied with the equipment. The connector is offered with 3 push-in spring connections, accommodates 0.2 to 2.5 mm² (24 to 12 AWG) wire size, and has a nominal current rating of 16A. Wire ends should be stripped, and a ferrule with plastic sleeve should be crimped onto the wire before it is inserted into the push-in connector.

Solenoid valves are wired straight onto the PCB terminal block on the MAC PCB. The terminal block offers 8 push-in spring connections, accommodates 0.2 to 1.5 mm² (24 to 16 AWG) wire size, and has a nominal current rating of 15A. Wire ends should be stripped, and a ferrule with plastic sleeve should be crimped onto the wire before it is inserted into the terminal.

All conductors should be kept as short as practical and shall not protrude from the input of the connector.

The figure below shows the designed instrument/sensor locations. The MAC PCBA is optimized to support this entry point configuration to ensure wires do not cross over the PCBA when installed. To configure the MAC differently than what is described in this manual, contact the manufacturer for further information (<https://www.endress.com/contact>).

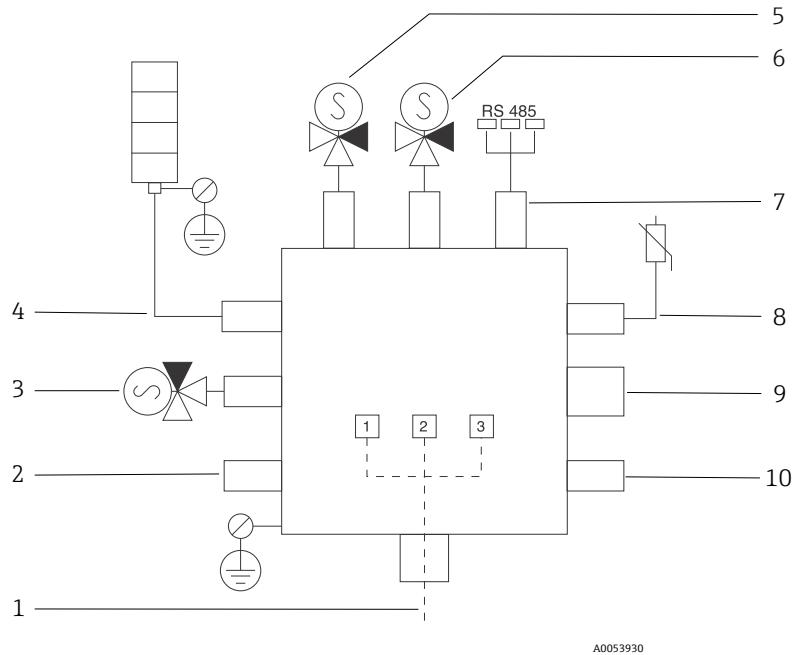

Figure 20. MAC enclosure designed instrument/sensor locations

#	Description												
1	Customer power entry AC 100 to 240 V ±10 % 50/60 HZ, 275W maximum DC 24 V ±10 %, 67W maximum												
	<table border="1"> <thead> <tr> <th>#</th> <th>AC 100 to 240 V option</th> <th>DC 24 V option</th> </tr> </thead> <tbody> <tr> <td>1</td> <td>Hot</td> <td>+24 V</td> </tr> <tr> <td>2</td> <td>Neutral main</td> <td>-24 V</td> </tr> <tr> <td>3</td> <td>Main ground</td> <td>open</td> </tr> </tbody> </table>	#	AC 100 to 240 V option	DC 24 V option	1	Hot	+24 V	2	Neutral main	-24 V	3	Main ground	open
#	AC 100 to 240 V option	DC 24 V option											
1	Hot	+24 V											
2	Neutral main	-24 V											
3	Main ground	open											
2	Not currently used Future solenoid entry												
3	Validation solenoid												
4	Sample conditioning system heater												
5	Cell/scrubber solenoid 2												
6	Cell/scrubber solenoid 1												
7	RS485 communication Intrinsically safe OHE RS485 interface connected with a cable to the OHE board in the optical head enclosure (Endress+Hauser integrator)												
8	Sample conditioning system thermistor												
9	Not currently used Future cell heater/cell thermistor entry												
10	Not currently used Future pump entry												

3.10 Electrical circuit breakers

The main electronic assembly shall be protected by an overcurrent protection rated for 10A or less.

NOTICE

The breaker shall not interrupt the protective earth conductor.

- ▶ If the breaker in the customer-provided power distribution panel or switch is the primary means of disconnecting the power from the analyzer, locate the analyzer so that the power distribution panel is near the equipment and within easy reach of the operator.

3.11 Connection values: signal circuits

3.11.1 Terminal assignment: controller

Input supply voltage		Input/output 1		Input/output 2		Input/output 3	
1 (+)	2 (-)	26 (B)	27 (A)	24 (+)	25 (-)	22 (+)	23 (-)
		Modbus RS485 only ⁵		Device-specific terminal assignment: refer to adhesive label on terminal cover			

3.11.2 Terminal assignments: MAC

The integrated MAC PCB features the connectors below. Connectors J2, J3, and J9 are for future implementations and are not currently used.

PCB identification marking	IS/non-IS	Intended use
J1 24V	Non-IS	Equipment manufacturer connection
J2 CELL THERM	Non-IS	Future equipment manufacturer connection
J3 PUMP	Non-IS	Future equipment manufacturer connection
J4 TO PS	Non-IS	Equipment manufacturer connection
J5 SCS THERM	IS	Equipment manufacturer connection or field wiring connection
J6 SOVs	Non-IS	Equipment manufacturer connection or field wiring connection
J7 OHE	IS	Equipment manufacturer connection
J9 CELL HTR	Non-IS	Future equipment manufacturer connection
J11 SCS HTR	Non-IS	Equipment manufacturer connection or field wiring connection
J12 AC IN or DC IN	Non-IS	Field wiring connection

Power input (AC 100 to 240 V ±10 % 50/60 Hz)	
J12 terminal 1	AC mains line
J12 terminal 2	AC mains neutral
J12 terminal 3	AC mains protective ground

Power input (DC 24 V ±20 %)	
J12 terminal 1	DC 24 V (+)
J12 terminal 2	DC 24 V (-)
J12 terminal 3	Not used

SCS heater	
J11 terminal 1	SCS heater AC line
J11 terminal 2	SCS heater AC neutral
J11 terminal 3	SCS heater protective ground

⁵ Terminals 26 and 27 are replaced by an RJ45 connector for Modbus TCP/IP.

Solenoid valves	
J6 terminal 1	Future solenoid use (-)
J6 terminal 2	Future solenoid use (+)
J6 terminal 3	Solenoid valve #3 (-)
J6 terminal 4	Solenoid valve #3 (+)
J6 terminal 5	Solenoid valve #2 (-)
J6 terminal 6	Solenoid valve #2 (+)
J6 terminal 7	Solenoid valve #1 (-)
J6 terminal 8	Solenoid valve #1 (+)

MAC PCBA AC 120 to 240 V connection

In the case of an AC mains power source from the customer connection, AC 100 to 240 V power is connected at J12, and the hot line is passed through fuse F4 to connector J4. A wiring harness from J4 is connected to the AC input of the DC 24 V power converter module. The DC 24 V output of the power converter module is connected by a wiring harness to J1.

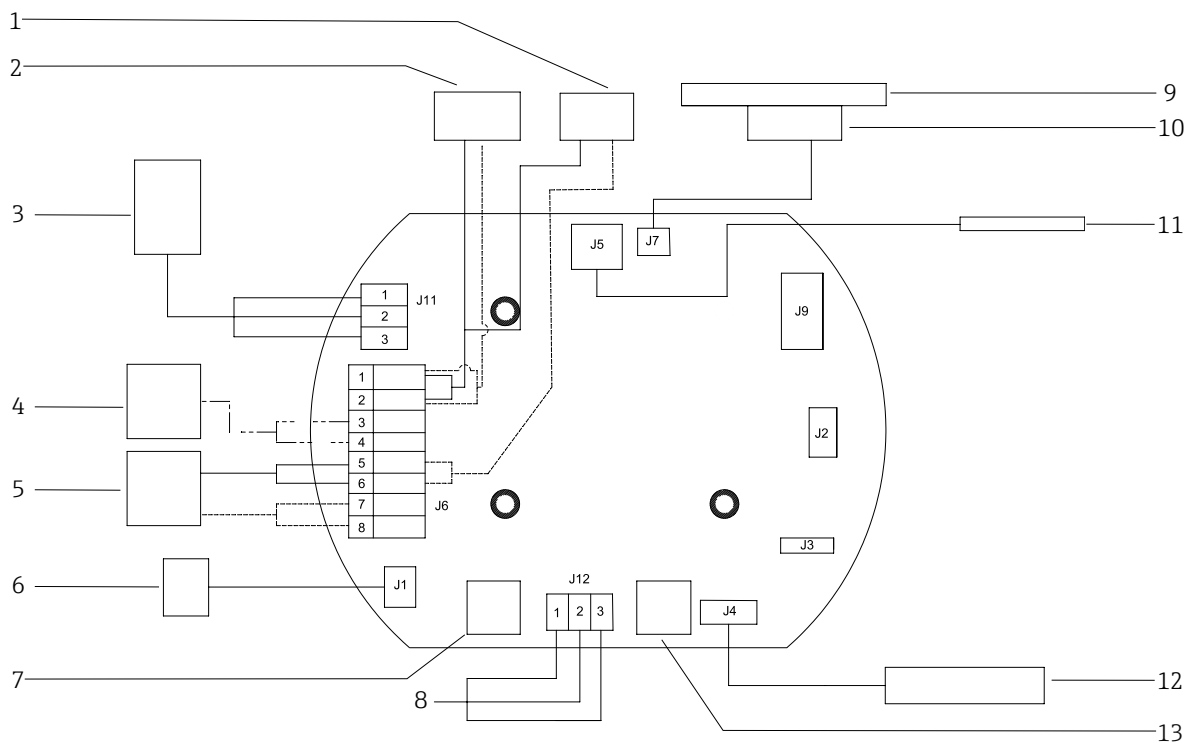

A0054783

Figure 21. MAC PCBA AC 120 to 240 V connection schematic

#	Description	#	Description	Legend	
1	SOV1, 24 V, 5.7W	8	Power in: AC 100 to 240 V ±10 %, 50/60 Hz, 275 W Customer interface	—	Electric SOV signal
2	SOV2, 24 V, 5.7W	9	J7 OHE PCBA	- - - - -	Pneumatic option electric SOV signal
3	SCS heater	10	OHE RS485	- · - · - · -	Optional feature
4	(optional) SOV4, DC 24 V, 5.7W	11	SCS thermistor	□	Mounting holes
5	SOV3, DC 24 V, 5.7W	12	To power supply IN	▨	Ground location
6	From power supply	13	MAC fuse AC 100 to 120 V options: 1.25A AC 230 to 240 V options: 1.25A		
7	Heater fuse AC 100 to 120 V options: 2.5A AC 230 to 240 V options: 1.25A				

MAC PCB DC 24 V connection

For the DC 24 V version, DC 24 V power is connected at J12 and passed through fuse F4 to connector J4. A wiring harness from J4 is connected to the DC 24 V input connector J1. A different value of fuse is specified for use with the 2 choices of customer power, and the part number to select for insertion into the fuse holder is specified on the schematic.

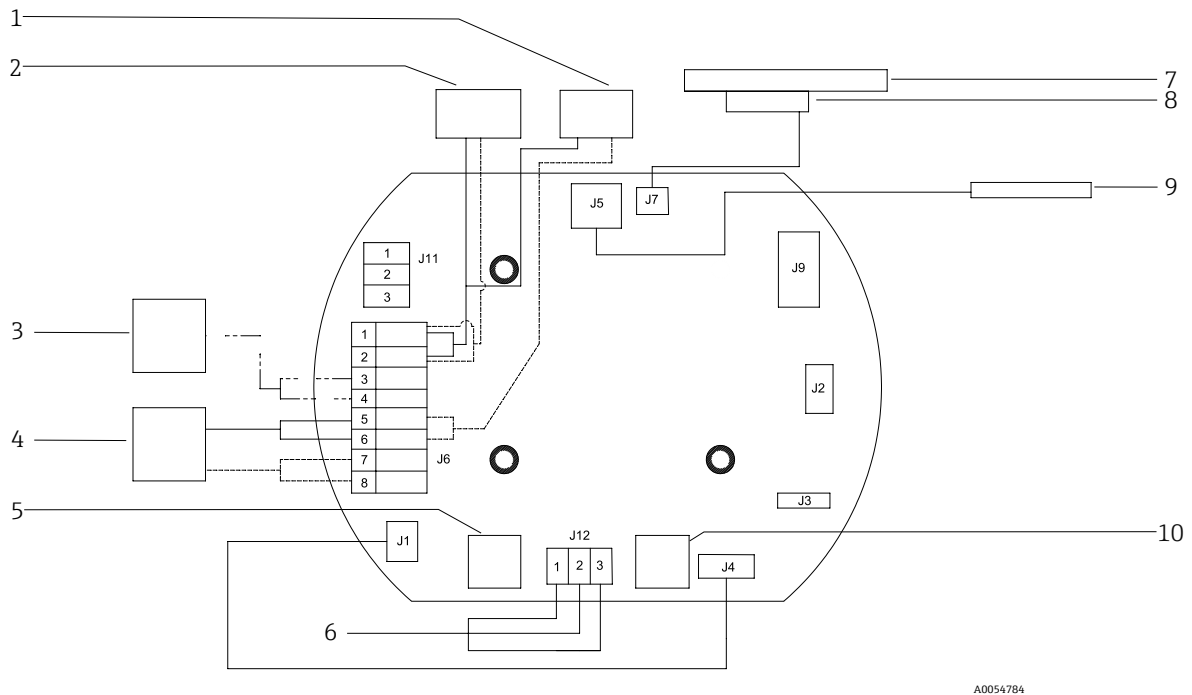

A0054784

Figure 22. MAC PCB DC 24 V connection schematic

#	Description	#	Description	Legend	
1	SOV1, DC 24 V, 5.7W	6	Power in: DC 24 V ±10 %, 67W maximum Customer interface	—	Electric SOV signal
2	SOV2, DC 24 V, 5.7W	7	J7 OHE PCBA	- - - - -	Pneumatic option electric SOV signal
3	(optional) SOV4, DC 24 V, 5.7W	8	OHE RS485	- · - · - · -	Optional feature
4	SOV3, DC 24 V, 5.7W	9	SCS thermistor	· · · · ·	Mounting holes
5	Heater fuse, not populated	10	MAC fuse, 4A	▨	Ground location

3.11.3 Safety-related values

Refer to *Analyzer technical specifications* →

3.11.4 Modbus interface cable specification

Cable type	A
Characteristic impedance	135 to 165 W at a measuring frequency of 3 to 20 MHz
Cable capacitance	< 30 pF/m
Wire cross-section	> 0.34 mm ² (22 AWG)
Cable type	Twisted pairs
Loop resistance	≤ 110 Ω/km

3.12 IS flow switch connection requirements

The JT33 analyzer can be offered with a variable flow meter equipped with an optional mechanical display and reed contact to measure the volume flow of flammable and nonflammable gases. See electrical parameters in *Analyzer technical specifications* → .

3.13 Connecting the gas supply

Consult the layout and flow diagrams in the system drawings in the operating instructions for supply and return port locations. All work shall be performed by technicians qualified in pneumatic tubing.

WARNING

Process samples may contain hazardous material in potentially flammable or toxic concentrations.

- ▶ Personnel shall have a thorough knowledge and understanding of the physical properties and safety precautions for the sample contents before connecting the gas supply.

3.14 Sample system heater

The purpose of the optional heater is to maintain the temperature of the sample system to avoid condensation in cold weather.

Manufacturer	Intertec
Power (140/200W)	AC 100/230 V tolerance $\pm 10\%$, 50/60 Hz
Power (160W)	AC 240 V tolerance $\pm 10\%$, 50/60 Hz
Ingress protection	IP68

4 Equipment operation

▲ CAUTION

- ▶ The safety of the analyzer is the responsibility of the installer and the organization they represent.

4.1 Operating controls

The JT33 analyzer is operated using the optical touch pad. Basic operating parameters are provided in the operating instructions. Refer to *Associated documentation* → .

The MAC is an accessory controller for various elements used in a sample conditioning system that supports the analyzer.

4.2 Commissioning

1. Power system on.
2. Set flow rates and pressure for system as specified in the system drawings provided in the operating instructions.
3. Ensure the sample vent has an unrestricted connection to atmosphere or flare, as specified.

NOTICE

The temperature of the process medium shall be within the ambient temperature rating of the equipment.

- ▶ Do not exceed specified pressure setting or equipment damage may occur.

4.3 Decommissioning

4.3.1 Intermittent operation

If the analyzer will be stored or shut down for any reason, follow the instructions for isolating the cell tube and SCS.

1. Purge the system:
 - a. Shut off the process gas flow.
 - b. Allow all residual gas to dissipate from the lines.
 - c. Connect a nitrogen (N₂) purge supply, regulated to the specified sample supply pressure, to the sample supply port.
 - d. Confirm that any valves controlling the sample flow effluent to the low-pressure flare or atmospheric vent are open.
 - e. Turn on the purge supply to purge the system and clear any residual process gases.
 - f. Turn off the purge supply.
 - g. Allow all residual gas to dissipate from the lines.
 - h. Close all valves controlling the sample flow effluent to the low-pressure flare or atmospheric vent.
2. Disconnect electrical connections to the system:
 - a. Disconnect power to the system.

▲ CAUTION

Confirm the power source is disconnected at the switch or circuit breaker. Make sure the switch or breaker is in the “OFF” position and locked with a padlock.

- b. Confirm all digital/analog signals are turned off at the location from which they are being monitored.
 - c. Disconnect the phase and neutral wires from the analyzer.
 - d. Disconnect the protective ground wire from the analyzer system.
3. Disconnect all tubing and signal connections.
 4. Cap all inlets and outlets to prevent foreign material such as dust or water from entering the system.
 5. Ensure the analyzer is free from dust, oils, or any foreign material. Follow the instructions found in *To clean the JT33 analyzer exterior* → .

6. Pack the equipment in the original packaging in which it was shipped, if available. If the original packaging material is no longer available, the equipment should be adequately secured to prevent excessive shock or vibration.
7. If returning the analyzer to the factory, complete the Decontamination Form provided by Endress+Hauser and attach to the outside of the shipping package as instructed before shipping. Refer to *Service* → .

5 Maintenance and service

Any repairs carried out by the customer or on behalf of the customer shall be recorded in a site dossier and kept available for inspectors. For more information on system repairs and replacements, see *Associated documentation* → .

WARNING

Process samples may contain hazardous material in potentially flammable or toxic concentrations.

- ▶ Personnel shall have a thorough knowledge and understanding of the physical properties and safety precautions for the sample contents before connecting the gas supply.

5.1 Cleaning and decontamination: JT33 analyzer

To clean the JT33 analyzer exterior

The housing should be cleaned only with a damp cloth to avoid electrostatic discharge.

NOTICE

- ▶ Never use vinyl acetate, acetone, or other organic solvents to clean the analyzer housing or labels.

5.2 Cleaning and decontamination: MAC

To clean the MAC exterior

The equipment should be cleaned only with a damp cloth to avoid electrostatic discharge.

5.3 Troubleshooting and repairs: JT33 analyzer

5.3.1 Cleaning the cell tube

Endress+Hauser does not recommend changing the cell tube. If the cell tube is contaminated, it can be cleaned.

Tools and materials

- Lint-free cloth
- Reagent-grade isopropyl alcohol (Cole-Parmer® EW-88361-80 or equivalent) or acetone
- Permanent ink marker
- Acetone-impenetrable gloves (North NOR CE412W Nitrile Chemsoft™ CE Cleanroom Gloves or equivalent)
- 4 mm Hex driver

To clean the cell tube

1. Power down the analyzer.
2. Isolate the SCS from the process sample flow.
3. If possible, purge the system with nitrogen for 10 minutes.
4. Mark the orientation of the cell tube on the transition plate with a permanent ink marker.

NOTICE

The cell tube is very heavy. Use caution when removing it from the transition plate and panel.

5. Remove the 4 screws connecting the cell tube to the transition plate.
6. Remove the screws connecting the bracket to the panel. Leave the bracket attached to the cell tube.
7. Put on clean acetone-impenetrable gloves.
8. Using a lint-free cloth, clean the tube with isopropyl alcohol or acetone.

NOTICE

Ensure the cell tube is properly aligned with the transition plate before re-attaching so the top mirror is not damaged.



9. Replace the cell tube in the same orientation as previously marked.

5.3.2 Cleaning the cell assembly mirror

If contamination makes its way into the cell and accumulates on the internal optics, a **Detector reference level range exceeded** fault will result.

When determining whether to perform this task, carefully review the notices and warnings below.

NOTICE

- ▶ Do NOT clean the top mirror. If the top mirror is visibly contaminated or scratched in the clean area (see *Required clean area on mirror* → ) , refer to *Service* → .
- ▶ Cell assembly mirror cleaning should only be performed when there is a small amount of contamination. Otherwise, refer to *Service* → .
- ▶ Careful marking of the mirror orientation is critical to restoring system performance upon reassembly after cleaning.
- ▶ Always handle the optical assembly by the edge of the mount. Never touch coated surfaces of the mirror.
- ▶ Pressurized gas duster products are not recommended for cleaning components. The propellant may deposit liquid droplets onto the optic surface.
- ▶ Never rub an optical surface, especially with dry tissues, as this can mar or scratch the coated surface.
- ▶ This procedure should be used ONLY when necessary and is not part of routine maintenance.

⚠ WARNING

INVISIBLE LASER RADIATION: The sample cell assembly contains a low-power, 35 mW maximum, CW Class 1 invisible laser with a wavelength between 750 to 3000 nm.

- ▶ Never open the sample cell flanges or the optical assembly unless the power is turned off.

⚠ WARNING

Process samples may contain hazardous material in potentially flammable and toxic concentrations.

- ▶ Personnel should have a thorough knowledge and understanding of the physical properties and safety precautions for the sample contents before operating the SCS.
- ▶ All valves, regulators, and switches should be operated in accordance with site lockout/tagout procedures.

The procedure for cleaning the cell assembly mirror is broken into 3 parts:

- Purging the SCS and removing the mirror assembly
- Cleaning the cell assembly mirror
- Replacing the mirror assembly and components

Tools and materials

- Lens cleaning cloth (Cole-Parmer® EW-33677-00 TEXWIPE® Alphawipe® Low-Particulate Clean Room Wipes or equivalent)
- Reagent-grade isopropyl alcohol (Cole-Parmer® EW-88361-80 or equivalent)
- Small drop dispenser bottle (Nalgene® 2414 FEP Drop Dispenser Bottle or equivalent)
- Acetone-impenetrable gloves (North NOR CE412W Nitrile Chemsoft™ CE Cleanroom Gloves or equivalent)
- Hemostats (Fisherbrand™ 13-812-24 Rochester-Pean Serrated Forceps or equivalent)
- Bulb blower or dry compressed air/nitrogen
- Torque wrench
- Permanent ink marker
- Non-outgassing grease
- Flashlight

To purge the SCS and remove the mirror assembly

1. Power down the analyzer.
2. Isolate the SCS from the process sample flow.
3. If possible, purge the system with nitrogen for 10 minutes.
4. Carefully mark the orientation of the mirror assembly with a permanent ink marker on the cell body.
5. Gently remove the mirror assembly from the cell by removing the 4 socket-head cap screws and set the mirror assembly on a clean, stable, and flat surface.

To clean the cell assembly mirror

1. Using a bulb blower or dry compressed air/nitrogen, remove dust and other large particles of debris.
2. Put on clean acetone-impenetrable gloves.
3. Double fold a clean sheet of lens cleaning cloth. Using hemostats or your fingers, clamp near and along the fold to form a "brush."
4. Place a few drops of isopropyl alcohol onto the mirror and rotate the mirror to spread the liquid evenly across the mirror surface.
5. With gentle, uniform pressure, wipe the mirror from one edge to the other with the cleaning cloth only once and only in one direction to remove the contamination. Discard the cloth.
6. Repeat with a clean sheet of lens cleaning cloth to remove the streak left by the first wipe.
7. Repeat step 6, if necessary, until there is no visible contamination in the required clean area of the mirror. In the figure below, the shaded ring shows the area of the mirror that must be clean and free of scratches.
8. If the mirror is not clean and free of scratches in the required area, replace the mirror assembly.

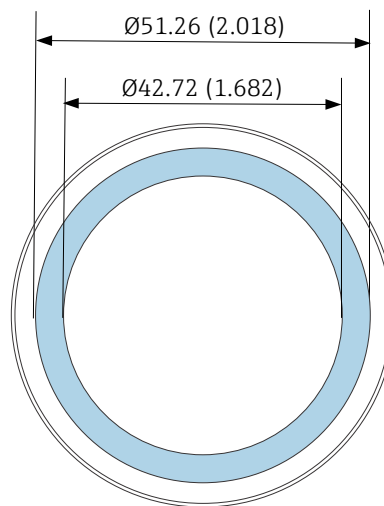

Figure 23. Required clean area on mirror. Dimensions: mm (in)

To replace the mirror assembly and components

1. Add a very thin layer of non-outgassing grease to the O-ring.
2. Replace the O-ring and ensure it is properly seated.
3. Carefully replace the mirror assembly onto the cell in the same orientation as previously marked.
4. Tighten the socket-head cap screws evenly with a torque wrench to 3.39 Nm (30 in-lbs).
5. Restart the system.

5.3.3 Replacing the membrane separator filter

Make sure that a membrane separator filter is operating normally. If liquid enters the cell and accumulates on the internal optics, a **Detector reference level range exceeded** fault will result.

To replace the membrane separator filter

1. Close the sample supply valve.
2. Unscrew the cap from the membrane separator.
3. Determine if the membrane filter is dry or if liquid/contaminants are present. Follow the appropriate steps below.

If the membrane filter is dry:

1. Check if there are any contaminants or discoloring of the white membrane. If yes, the filter should be replaced.
2. Remove the O-ring and replace the membrane filter.
3. Replace the O-ring on top of the membrane filter.
4. Place the cap back onto the membrane separator and tighten.
5. Check upstream of the membrane for liquid contamination and clean and dry out before reopening the sample supply valve.

If liquid or contaminants are detected on the filter:

1. Drain any liquids and clean with isopropyl alcohol.
2. Clean any liquids or contaminants from the base of the membrane separator.
3. Replace the filter and the O-ring.
4. Place the cap onto the membrane separator and hand tighten.
5. Check upstream of the membrane for liquid contamination and clean and dry out before reopening the sample supply valve.

5.3.4 Enclosure purge (optional)

The optional enclosure purge is typically performed when the sample gas contains high concentrations of H₂S. When maintenance of the JT33 analyzer is required, follow 1 of the 2 methods for purging the enclosure described below prior to opening the enclosure door.

To purge the enclosure with a gas sensor

 **WARNING**

- ▶ Ensure an appropriate sensor is used based on the toxic components in the process gas stream.
1. Allow the sample gas to continue flowing through the system.
 2. Open the tee fitting cap on the exhaust port on the lower right side of the enclosure and insert a sensor to determine if there is H₂S inside the enclosure.
 3. If no hazardous gas is detected, proceed with opening the enclosure door.
 4. If hazardous gas is detected, follow the instructions below for purging the enclosure.

To purge the enclosure without a gas sensor

1. Turn off the sample gas to the system.
2. Connect the purge gas to the purge inlet on the upper right side of the enclosure.
3. Open the exhaust on the bottom right side of the enclosure and connect a piece of tubing that vents to safe area.
4. Input the purge gas at 10 liters per minute (0.35 scfm).
5. Operate the purge for 20 minutes.

5.3.5 Sample system purge (optional)

1. Shut off gas to the analyzer.
2. Ensure the vent and bypass, if present, are open.
3. Connect the purge gas to 'sample purge in' port.
4. Switch the gas select valve from 'sample in' to 'purge in.'
5. Set the flow rate to 3 liters per minute and run the purge for at least 10 minutes for safety.

5.3.6 Repair verification

When repairs have been completed correctly, alarms will clear from the system.

CAUTION

Residual risk. Capacitors may remain charged with high voltage in the case of a single fault.

- ▶ Allow 10 minutes before controller covers are opened.

5.3.7 Power termination covers

Confirm the termination cover is closed before initiating operation or after a repair event. Should the cover become damaged, it must be replaced to avoid potential safety risk.

5.4 Troubleshooting and repairs: MAC

The MAC is part of certain models of the JT33 analyzer.

NOTICE

- ▶ All MAC service should be performed by a certified user.
- ▶ Category 3: Elements allowed to be replaced in the field by the manufacturer:
 - MAC printed circuit board assembly (PCBA)
 - Power supply
 - Thermal cutoff
- ▶ Category 1: Elements allowed to be replaced in the field by the customer:
 - Electrical fuses
 - O-ring
 - Fuses
 - Terminal block, plug

Tools and materials

- New fuses
 - F4 or F5
 - Thermal fuses rated up to 77 °C
- 2.5 mm hex for TDK power supply removal
- 2 mm hex for Cincon power supply removal
- 5 mm flathead for fuse removal
- 2.5 mm flathead for power and SCS heater hookups
- #2 Phillips screwdriver for power support cage removal
- 20 x 20 x 165 mm bar for MAC cover removal
- 2 x 41 mm crescent wrench for servicing solenoids
- Ferrule crimping tool SQ28-10 or TRAP24-10
- Syntheso Glep 1, grease
- Hardware that came with new power supply order

5.4.1 Removing the MAC stackup

Remove the MAC stackup to replace the thermal fuses, MAC PCBA, PCBA cover or power supply.

1. Disconnect all internal harnesses from the MAC PCBA, including the protective ground wire linking J12-3 to the enclosure.
2. Pull the harnesses out of the enclosure through the main cavity in which the cover threads onto.
3. Tape the harnesses along the rim/threaded section of the enclosure.
4. Use a #2 Phillips screwdriver to remove the four #10-32 captive panel screws shown in the figure below.

5. Remove the stackup vertically out of the enclosure.

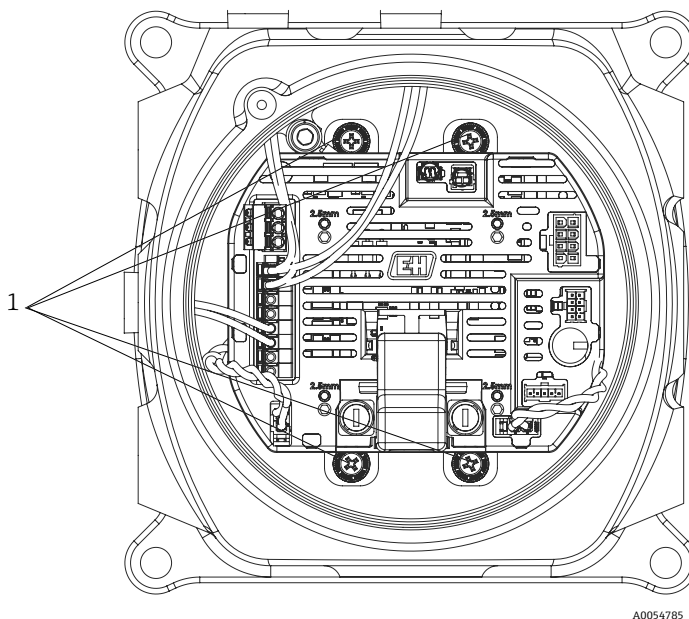

Figure 24. Captive panel screw locations (1)

5.4.2 Replacing fuses

⚠ WARNING

Fuses are voltage dependent. Be aware of the appropriate amperage.

- ▶ The MAC PCBA has 2 fuses. F4 ensures the MAC is not damaged and the F5 ensures the heater is not damaged. Refer to the figure below before servicing.
 - All fuses should be approved according to IEC 60127-2/1 and CSA22.2 No. 248.14.
 - If servicing an AC 100 or 120 V system, the heater fuse (F5) is 2.5A and the MAC fuse (F4) is 1.25A.
 - If servicing an AC 230 or 240 V system, the heater fuse (F5) is 1.25A and the MAC fuse (F4) is 1.25A.
 - If servicing a 24 V system, the MAC fuse (F4) is 4A and no fuse is inserted in the heater slot.

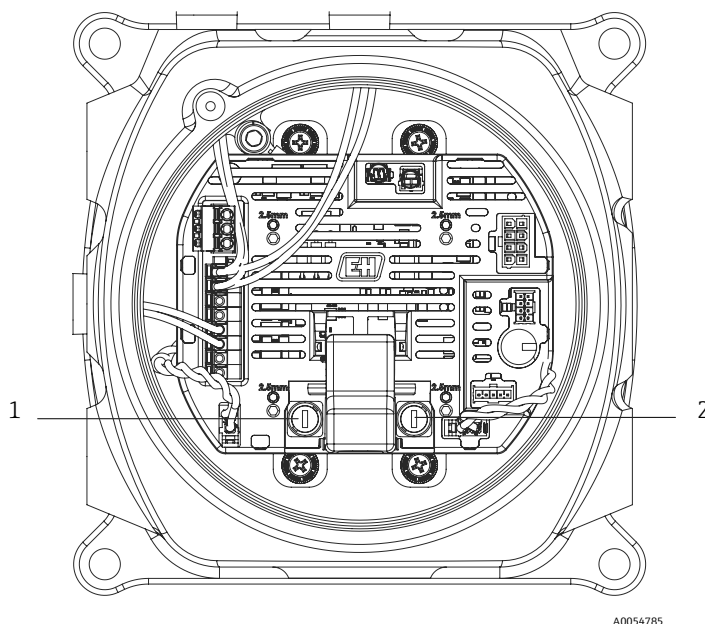



Figure 25. MAC PCBA fuse locations

#	Name
1	SCS heater holder
2	MAC fuse holder

To replace the F4 or F5 fuses

1. Using the 5 mm flathead screwdriver, rotate the fuse holder cap counterclockwise.
2. Lift off the cap from the MAC PCBA.
3. Insert the new fuse into the cap.
4. Install the cap into the fuse holder by rotating clockwise until the cap is properly seated in the holder.

To replace the thermal fuses

1. Remove the MAC stackup. See *Removing the MAC stackup* → .

WARNING

- ▶ Do not remove the MAC cover from the enclosure unless the area is known to be free from explosive gas in the atmosphere.

2. Remove the cover.

The fuses are not polarity dependent, and therefore can be installed in any orientation. The SCS heater cutoff fuse is in the lower left side of the PCBA and the cell heater cutoff is in the right side of the board. See the figure below.

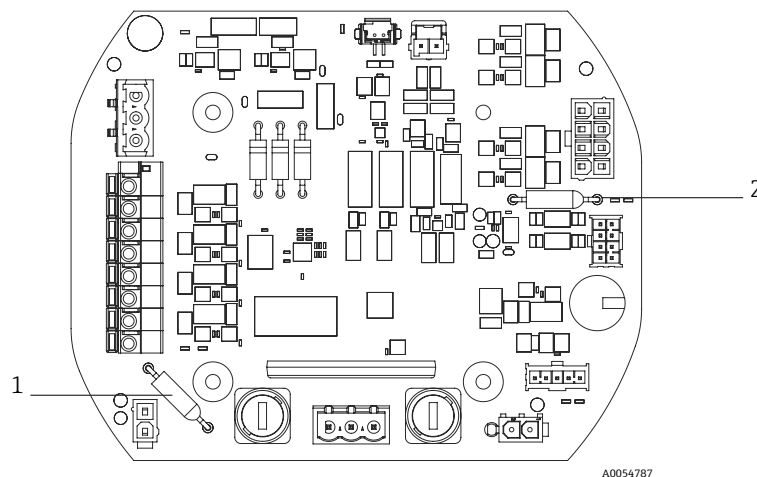



Figure 26. Thermal fuse cutoff locations

#	Name
1	SCS heater thermal cutoff
2	Cell heater thermal cutoff

3. Remove the fuses from their pin sockets mounted on the PCBA.
4. Insert the replacement fuses. No soldering is needed.

5.4.3 Replacing the MAC PCBA

1. Remove the MAC stackup. See *Removing the MAC stackup* → .
2. Remove the cover and the four M3x0.5 socket head cap screws that mount the PCBA to the stackup.
3. Install the new MAC PCBA using the same head cap screws.
4. The M3 x 0.5 head cap screws should be torqued down to 2.0 Nm (17.7 lb-in).
5. Replace the MAC cover.
6. Install the harnesses back to their proper locations.

5.4.4 Replacing the power supply

1. Remove the MAC stackup. See *Removing the MAC stackup* → .
2. Loosen the 4 socket head cap screws.
 - For the TDK variant, use a 2.5 mm hex to remove the M3 x 0.5 screws.
 - For the Cincon variant, use a 2 mm hex to remove the M2.5 x 0.5 screws.
3. Remove the hardware from the power support cage under the MAC.
4. Remove the power supply.
5. Install the replacement power supply into the assembly in the same orientation it was removed. Use the new hardware that came with the replacement order. Refer to the figure below.
 - To replace the TDK power supply, orient the 2-pin connector toward the “AC IN” on the power support cage.
 - To replace the Cincon power supply, install the 3-pin connector facing the “AC IN.”

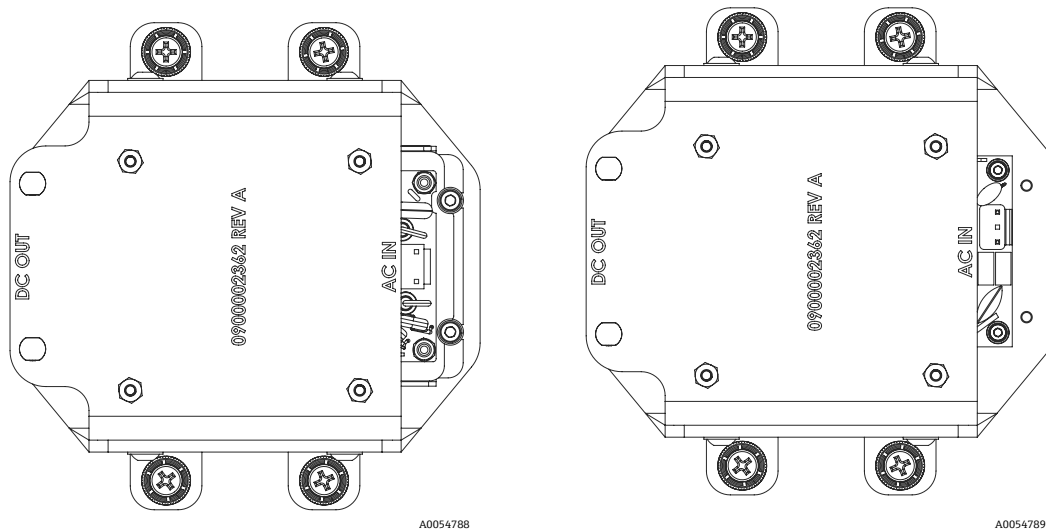

Figure 27. Power supply installation orientation: TDK (left) and Cincon (right)

5.4.5 Removing the Ex d cover

1. Use a 2.5 mm hex to rotate the locking screw clockwise to relax the force applied on the bottom of the cover.
2. After the locking screw is backed off, remove the cover by rotating counterclockwise by hand.

Alternatively, use a 20 x 20 x 165 mm square bar (not issued by Endress+Hauser) to help remove the cover. Refer to the figure below.

NOTICE

- ▶ Anything longer than the square bar listed may collide with SCS components.

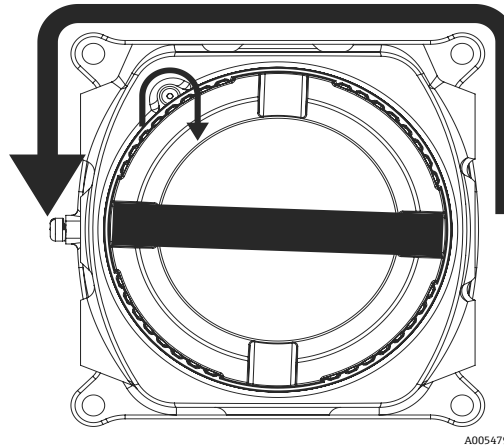

Figure 28. Removing the MAC cover

3. After removing the cover or glands from an entry point on the MAC enclosure, inspect all threads for galling or deformation.

If threads are damaged, send the replacement enclosure or glands for service to ensure hazardous requirements are met. This cannot be repaired in the field.

4. Clean the threads and O-ring and apply a light coating of Synetheso Glep 1.
5. Install the cover back onto the enclosure.

5.4.6 Servicing the solenoids

1. When servicing the two solenoids that control the differential stream switching logic, cut off the ferrules that are installed into the MAC to remove the assembly.

When installing back into the enclosure, reinstall the two 2x22 AWG insulated nylon ferrules on both solenoids using the appropriate crimping tool.

2. When servicing the validation solenoid, the ferrules usually do not need to be replaced.

If an issue arises with the barrier gland, the ferrules may need to be replaced using the appropriate crimping tool.

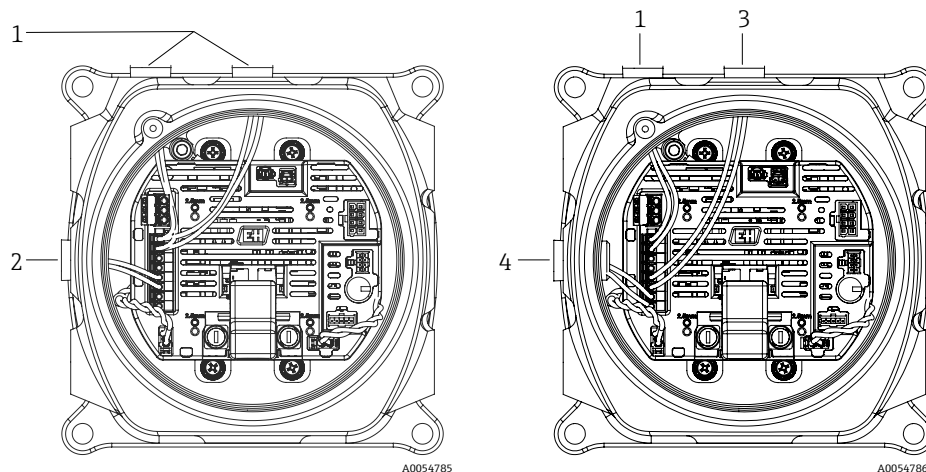

Figure 29. Solenoid wiring: electrical (left) and pneumatic (right) configurations

#	Name
1	Differential solenoid
2	Validation solenoid
3	Validation 1 solenoid
4	Validation 2 solenoid

5.5 Spare parts

All spare parts for the analyzer, along with their order codes, are listed in the spare parts finder tool on the Endress+Hauser website.

Spare parts finder tool: www.endress.com/product-tools

5.6 Service

For Service, refer to our website (<https://www.endress.com/contact>) for the list of local sales channels in your area.

www.addresses.endress.com
