

# Safety Instructions

## Micropilot

### FMR50/51/52/53/54/56/57

#### 4-20 mA HART, 2-wire, 4...20 mA

Ex ia IIC T6 Ga



Document: XA01288F-A

Safety instructions for electrical apparatus for explosion-hazardous areas



# Micropilot

## FMR50/51/52/53/54/56/57

4-20 mA HART

### Table of Contents

Associated documentation . . . . .	4
Supplementary documentation . . . . .	4
Manufacturer's certificates . . . . .	4
Extended order code . . . . .	4
Safety instructions: General . . . . .	6
Safety instructions: Special conditions . . . . .	6
Safety instructions: Installation . . . . .	7
Safety instructions: Zone 0 . . . . .	8
Temperature tables . . . . .	8
Connection data . . . . .	8

<b>Associated documentation</b>	<p>This document is an integral part of the following Operating Instructions:  BA01045F/00 (FMR50), BA01049F/00 (FMR51/52), BA01050F/00 (FMR53/54),  BA01048F/00 (FMR56/57)</p> <p>The Operating Instructions pertaining to the device apply.</p>									
<b>Supplementary documentation</b>	<p>Explosion-protection brochure:  CP00021Z/11</p> <p>The Explosion-protection brochure is available:</p> <ul style="list-style-type: none"> <li>■ In the download area of the Endress+Hauser website: <a href="http://www.endress.com">www.endress.com</a> → Download → Advanced → Documentation Code: CP00021Z</li> <li>■ On the CD for devices with CD-based documentation</li> </ul>									
<b>Manufacturer's certificates</b>	<p><b>Certificate of Conformity</b></p> <p>Certificate number:  TÜV 13.2010 X</p> <p>Affixing the certificate number certifies conformity with the standards under <a href="http://www.abnt.org.br">www.abnt.org.br</a> (depending on the device version).</p> <ul style="list-style-type: none"> <li>■ ABNT NBR IEC 60079-0 : 2008</li> <li>■ ABNT NBR IEC 60079-11 : 2009</li> <li>■ ABNT NBR IEC 60079-26 : 2008</li> </ul>									
<b>Extended order code</b>	<p>The extended order code is indicated on the nameplate, which is affixed to the device in such a way that it is clearly visible. Additional information about the nameplate is provided in the associated Operating Instructions.</p> <p><b>Structure of the extended order code</b></p> <table border="0" style="margin-left: 40px;"> <tr> <td style="text-align: center;">FMR5x</td> <td style="text-align: center;">- *****</td> <td style="text-align: center;">+ A*B*C*D*E*F*G*..</td> </tr> <tr> <td style="text-align: center;">-----</td> <td style="text-align: center;">-----</td> <td style="text-align: center;">-----</td> </tr> <tr> <td style="text-align: center;">Device type</td> <td style="text-align: center;">Basic specifications</td> <td style="text-align: center;">Optional specifications</td> </tr> </table> <p>* = Placeholder</p> <p>At this position, an option (number or letter) selected from the specification is displayed instead of the placeholders.</p> <ul style="list-style-type: none"> <li>■ Basic specifications  The features that are absolutely essential for the device (mandatory features) are specified in the basic specifications. The number of positions depends on the number of features available.  The selected option of a feature can consist of several positions.</li> <li>■ Optional specifications  The optional specifications describe additional features for the device (optional features).  The number of positions depends on the number of features available.  The features have a 2-digit structure to aid identification (e.g. JA). The first digit (ID) stands for the feature group and consists of a number or a letter (e.g. J = test, certificate). The second digit constitutes the value that stands for the feature within the group (e.g. A = 3.1 material (wetted parts), inspection certificate).</li> </ul> <p>More detailed information about the device is provided in the following tables. These tables describe the individual positions and IDs in the extended order code which are relevant to hazardous locations.</p>	FMR5x	- *****	+ A*B*C*D*E*F*G*..	-----	-----	-----	Device type	Basic specifications	Optional specifications
FMR5x	- *****	+ A*B*C*D*E*F*G*..								
-----	-----	-----								
Device type	Basic specifications	Optional specifications								

## Device type: FMR50, FMR51, FMR52, FMR53, FMR54, FMR56, FMR57

## Basic specifications

Position	Selected option	Description
1, 2 Approval	FMR5x MA	Ex ia IIC T6 Ga
3 Power Supply; Output	FMR5x C	2-wire, 4-20 mA HART, 4...20 mA
4 Display; Operation	FMR5x A C E L *1 M *1	Without, via communication SD02 4-line, push buttons + data backup function SD03 4-line, illum., touch control + data backup function Prepared for display FHX50 + M12 connection Prepared for display FHX50 + custom connection
5 Housing	FMR51-54/57 B	Dual compartment, 316L (GT18)
	FMR5x A	Dual compartment, plastics PBT (GT19)
	C	Dual compartment, Alu coated (GT20)
7, 8 Antenna	FMR50 BM BN BR	Horn 40 mm/1½", PVDF encapsulated, -40...130 °C Horn 80 mm/3", PP cladded, -40...80 °C Horn 100 mm/4", PP cladded, -40...80 °C
	FMR51 Bx	Horn (different sizes)
	FMR52 BO BP	Horn 50 mm/2", -40...200 °C, flush mount Horn 80 mm/3", -40...200 °C, flush mount
	FMR53 Cx	Rod (different sizes)
	FMR54 Ax Bx Dx	Without Horn Horn (different sizes) Planar (different sizes)
	FMR56 BN BR	Horn 80 mm/3", PP cladded, -40...80 °C Horn 100 mm/4", PP cladded, -40...80 °C
	FMR57 Bx Fx	Horn (different sizes) Parabolic (different sizes)
9, 10 Seal	FMR51 A5 C1 D2 D3	Viton GLT, -40...150 °C Kalrez, -20...150 °C Graphite, -196...450 °C (HT) Graphite, -40...250 °C (XT)
	FMR54 A7 A8 B4 C2 D1 D2	Viton, -20...150 °C (Planar) Viton, -40...200 °C EPDM, -40...150 °C Kalrez, -20...200 °C, conductive media max. 150 °C Graphite, -196...280 °C (XT) Graphite, -196...400 °C (HT)
	FMR57 A6 D4	Viton GLT, -40...200 °C Graphite, -40...400 °C (HT)
11-13 Process Connection	FMR51-54/57 Axx, Cxx, Kxx	Flange (different sizes)
	FMR50 GGF, RGF	Thread, PVDF
	FMR51 Pxx Rxx Txx	Flange (different sizes) Thread, 316L and PVDF Tri-Clamp
	FMR52 Mxx Txx	Slotted-nut Tri-Clamp
	FMR53 Rxj RxF	Thread, 316L Thread, PVDF

Position	Selected option	Description
11-13 Process Connection	FMR50/56 UAE XRO XxG	Mounting bracket Connection, without flange/mounting bracket Slip on flange (different sizes)
	FMR57 RxJ XxJ	Thread, 316L Align. device (different sizes)

\*1 In connection with "Housing" = "A": Observe the specifications in the "Overvoltage protection" (→ 7) and "Temperature tables" (→ 8) chapters!

#### Optional specifications

ID	Selected option	Description
Nx, Accessory Ox Mounted	FMR5x NA	Overvoltage protection
	FMR51/57 OW	Horn protection, PTFE, no airpurge possible

#### Safety instructions: General

- Staff must meet the following conditions for mounting, electrical installation, commissioning and maintenance of the device:
  - Be suitably qualified for their role and the tasks they perform
  - Be trained in explosion protection
  - Be familiar with national regulations
- Install the device according to the manufacturer's instructions and national regulations.
- Do not operate the device outside the specified electrical, thermal and mechanical parameters.
- Only use the device in media to which the wetted materials have sufficient durability.
- Avoid electrostatic charging:
  - Of plastic surfaces (e.g. housing, sensor element, special varnishing, attached additional plates, ..)
  - Of isolated capacities (e.g. isolated metallic plates)
- Refer to the temperature tables for the relationship between the permitted ambient temperature for the sensor and/or transmitter, depending on the range of application, and the temperature class.
- Modifications to the device can affect the explosion protection and must be carried out by staff authorized to perform such work by Endress+Hauser.

#### Safety instructions: Special conditions

Permitted ambient temperature range at the electronics housing:  $-40\text{ °C} \leq T_a \leq +80\text{ °C}$ .  
Observe the information in the temperature tables.

Basic specification, Position 5 (Housing) = C

- In Zone 0, avoid sparks caused by impact and friction.

Basic specification, Position 5 (Housing) = A

- Avoid electrostatic charging of the housing (e.g. friction, cleaning, maintenance, strong medium flow).

Device type FMR50, FMR52, FMR53, FMR54 (planar, enamel), FMR56

- An antenna coated with non-conductive material can be used if avoiding electrostatic charging (e.g. through friction, cleaning, maintenance, strong medium flow).

Device type FMR51, FMR57 and Optional specification, ID Ox (Accessory Mounted) = OW

- An antenna coated with non-conductive material can be used if avoiding electrostatic charging (e.g. through friction, cleaning, maintenance, strong medium flow).
- In the case of process connections made of polymeric material or with polymeric coatings, avoid electrostatic charging of the plastic surfaces.
- In the event of additional or alternative special varnishing on the housing or other metal parts:
  - Observe the danger of electrostatic charging and discharge.
  - Do not rub surfaces with a dry cloth.

## Safety instructions: Installation

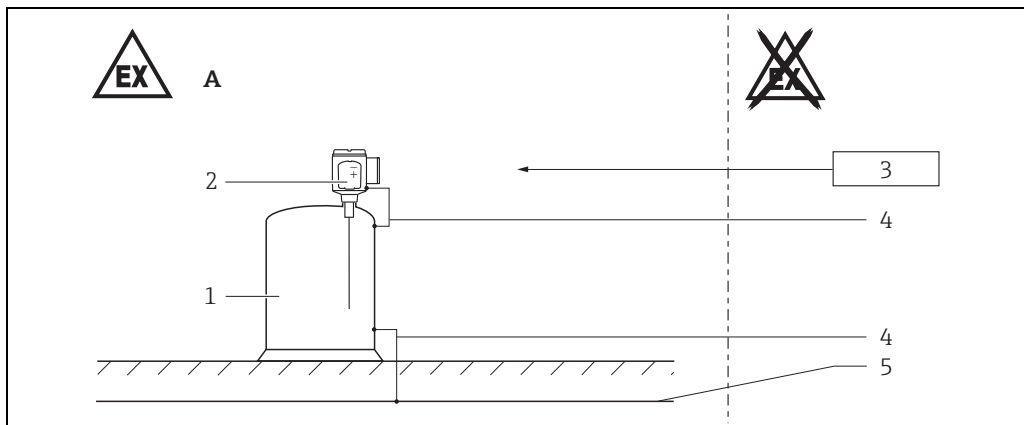

FMP5x\_01



- A** Zone 0, Zone 1
- 1 Tank; Zone 0, Zone 1
- 2 Electronic insert
- 3 Certified associated apparatus
- 4 Potential equalization line
- 5 Potential equalization

- After aligning (rotating) the housing, retighten the fixing screw (see Operating Instructions).
- When mounting the device:
  - Exclude any mechanical damage or friction during the application.
  - Pay particular attention to flow conditions and tank fittings.
- Continuous service temperature of the connecting cable:  $-40$  to  $\geq +85$  °C; in accordance with the range of service temperature taking into account additional influences of the process conditions ( $T_{a,min}$ ), ( $T_{a,max} + 20$  K).

### Intrinsic safety

- The device is only suitable for connection to certified, intrinsically safe equipment with explosion protection Ex ia / Ex ib.
- The intrinsically safe input power circuit of the device is isolated from ground. If the device is only equipped with one input, the dielectric strength of the input is at least  $500 V_{rms}$ . If the device is equipped with more than one input, the dielectric strength of each individual input to ground is at least  $500 V_{rms}$ , and the dielectric strength of the inputs vis-à-vis one another is also at least  $500 V_{rms}$ .
- Observe the pertinent guidelines when interconnecting intrinsically safe circuits.
- The device can be connected to the Endress+Hauser FXA291 service tool: refer to the Operating Instructions and specifications in the "Overvoltage protection" ( $\rightarrow$  7) chapter.
- When the intrinsically safe Ex ia circuits of the device are connected to certified intrinsically safe circuits of Category Ex ib for Equipment Groups IIC or IIB, the type of protection changes to Ex ib|ia| IIC or Ex ib|ia| IIB.  
Regardless of the power supply, all the internal circuits correspond to Ex ia IIC type of protection (e.g. service interface, external display, sensor).

### Potential equalization

- Integrate the device into the local potential equalization.

### Overvoltage protection

- If an overvoltage protection against atmospheric over voltages is required: no other circuits may leave the housing during normal operation without additional measures.
- For installations which require overvoltage protection to comply with national regulations or standards, install the device using overvoltage protection (e.g. HAW56x from Endress+Hauser).
- Observe the safety instructions of the overvoltage protection.

Optional specification, ID Nx (Accessory Mounted) = NA  
(Overvoltage protection TRC [16], type OVP10 and TRC [17], type OVP20)

- The intrinsically safe input power circuit of the device is isolated from ground. If the device is only equipped with one input, the dielectric strength of the input is at least  $290 V_{\text{rms}}$ . If the device is equipped with more than one input, the dielectric strength of each individual input to ground is at least  $290 V_{\text{rms}}$ , and the dielectric strength of the inputs vis-à-vis one another is also at least  $290 V_{\text{rms}}$ .

### Safety instructions: Zone 0

- In the event of potentially explosive vapor/air mixtures, only operate the device under atmospheric conditions.
  - Temperature:  $-20$  to  $+60$  °C
  - Pressure: 80 to 110 kPa (0.8 to 1.1 bar)
  - Air with normal oxygen content, usually 21 % (V/V)

If no potentially explosive mixtures are present, or if additional protective measures have been taken, the device may also be operated under non-atmospheric conditions in accordance with the manufacturer's specifications.

- Associated devices with galvanic isolation between the intrinsically safe and non-intrinsically safe circuits are preferred.
- Only use the device in media to which the silicone rubber potting compound of the electronic insert and the housing made of PBT, aluminum or 316L have sufficient durability.
- If there is a risk of dangerous potential differences within Zone 0 (e.g. through the occurrence of atmospheric electricity), implement suitable measures for intrinsically safe circuits in Zone 0.

### Temperature tables

→ 11



Caution!

Optional specification, ID Nx (Accessory Mounted) = NA  
(Overvoltage protection TRC [16], type OVP10 and TRC [17], type OVP20)

- When using the internal overvoltage protection: Reduce the admissible ambient temperature at the housing by 2 K.

Basic specification, Position 5 (Housing) = A

- When using the remote display FHX50: Reduce the admissible ambient temperature at the housing by 3 K.

### Connection data

Optional specification, ID Nx (Accessory Mounted) = NA  
(Overvoltage protection TRC [16], type OVP10 and TRC [17], type OVP20)

- When using the internal overvoltage protection: No changes to the connection values.

Basic specification, Position 1, 2 (Approval) = MA

#### Ex ia

- Power supply and signal circuit with protection type: intrinsic safety Ex ia IIC or IIB.

Basic specification, Position 3 (Power Supply; Output) = C (TRC [04])

Terminal 1 (+), 2 (-)	Terminal 3 (+), 4 (-)
Power supply: $U_i = 30$ V $I_i = 300$ mA $P_i = 1$ W effective inner inductance $L_i = 0$ $\mu$ H effective inner capacitance $C_i = 30$ nF	Output 4...20 mA: $U_i = 30$ V $I_i = 300$ mA $P_i = 1$ W effective inner inductance $L_i = 0$ $\mu$ H effective inner capacitance $C_i = 30$ nF



**Service interface (CDI)**

Taking the following values into consideration, the device can be connected to the certified Endress+Hauser FXA291 service tool or a similar interface:

Service interface													
$U_i = 7.3 \text{ V}$ effective inner inductance $L_i = \text{negligible}$ effective inner capacitance $C_i = \text{negligible}$													
$U_o = 7.3 \text{ V}$ $I_o = 100 \text{ mA}$ $P_o = 160 \text{ mW}$													
$L_o \text{ (mH)} =$	5.00	2.00	1.00	0.50	0.20	0.10	0.05	0.02	0.01	0.005	0.002	0.001	
$C_o \text{ (}\mu\text{F)} =$	0.73	1.20	1.60	2.00	2.60	3.20	4.00	5.50	7.30	10.00	12.70	12.70	



# Temperature tables

## Table of Contents

General notes .....	12
Diagram .....	12
Antenna and electronics housing: Zone 1	
FMR50, Position 7, 8 (Antenna) = BM .....	13
FMR50, Position 7, 8 (Antenna) = BN, BR .....	13
FMR51 .....	14
FMR51, Position 9, 10 (Seal) = D3 .....	15
FMR51, Position 9, 10 (Seal) = D2 .....	16
FMR52, Position 7, 8 (Antenna) = BO .....	18
FMR52, Position 7, 8 (Antenna) = BP .....	19
FMR53, Position 11-13 (Process Connection) = RxF .....	20
FMR53 .....	21
FMR54 .....	22
FMR54, Position 9, 10 (Seal) = D1 .....	23
FMR54, Position 9, 10 (Seal) = D2 .....	24
FMR54, Position 7, 8 (Antenna) = Dx .....	25
FMR56, Position 7, 8 (Antenna) = BN, BR .....	26
FMR57 .....	27
FMR57, Position 9, 10 (Seal) = D4 .....	28
Antenna and electronics housing: Zone 0	
FMR5x .....	30

**General notes**



Unless otherwise indicated, the positions always refer to the basic specification.

Note!

Observe the permitted temperature range at the antenna.

\*1 = Functional

Max. permissible process temperature

**Selection table**

Position 1, 2 (Approval)		Position 5 (Housing)	
MA	Ex ia IIC T6 Ga	A	GT19 dual compartment, plastics PBT
		B	GT18 dual compartment, 316L
		C	GT20 dual compartment, Alu coated

Position 3 (Power Supply; Output)	Transmission code of the terminal module	Channels
C	2-wire, 4-20 mA HART, 4...20 mA	TRC [04]
		1 or 2 channels used

**Diagram**

**Example diagrams to the temperature tables**

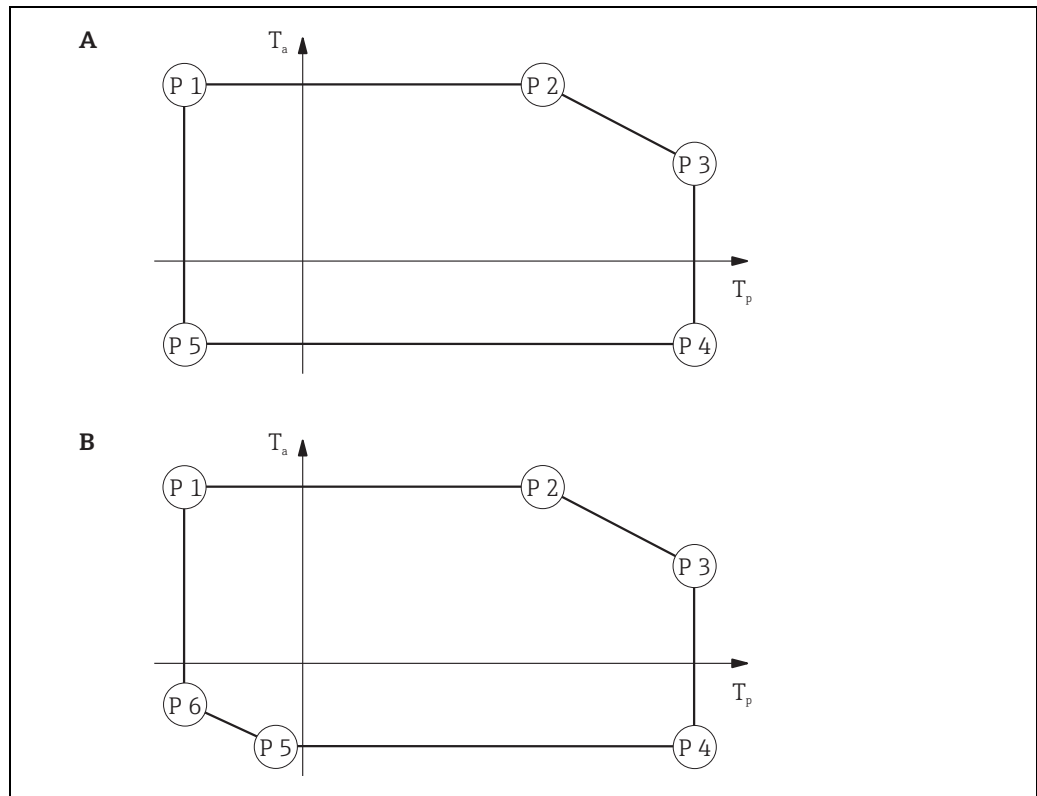

- A** Version 1
- B** Version 2

$T_a$  Ambient temperature  
 $T_p$  Process temperature

**Antenna and electronics housing: Zone 1**

**FMR50**, Position 7, 8 (Antenna) = BM

**Position 3 (Power Supply; Output) = C (TRC [04])**

Position 5 (Housing) = A													
Power Supply; Output	Temperature class	P 1		P 2		P 3		P 4		P 5		P 6	
		T <sub>p</sub>	T <sub>a</sub>	T <sub>p</sub>	T <sub>a</sub>	T <sub>p</sub>	T <sub>a</sub>	T <sub>p</sub>	T <sub>a</sub>	T <sub>p</sub>	T <sub>a</sub>	T <sub>p</sub>	T <sub>a</sub>
1 channel used	T6 ( 85 °C)	-40 °C	60 °C	60 °C	60 °C	80 °C	56 °C	80 °C	-40 °C	-40 °C	-40 °C	-	-
2 channels used	T6 ( 85 °C)	-40 °C	53 °C	53 °C	53 °C	80 °C	49 °C	80 °C	-40 °C	-40 °C	-40 °C	-	-

Position 5 (Housing) = C													
Power Supply; Output	Temperature class	P 1		P 2		P 3		P 4		P 5		P 6	
		T <sub>p</sub>	T <sub>a</sub>	T <sub>p</sub>	T <sub>a</sub>	T <sub>p</sub>	T <sub>a</sub>	T <sub>p</sub>	T <sub>a</sub>	T <sub>p</sub>	T <sub>a</sub>	T <sub>p</sub>	T <sub>a</sub>
1 channel used	T6 ( 85 °C)	-40 °C	60 °C	60 °C	60 °C	80 °C	58 °C	80 °C	-40 °C	-40 °C	-40 °C	-	-
2 channels used	T6 ( 85 °C)	-40 °C	54 °C	54 °C	54 °C	80 °C	53 °C	80 °C	-40 °C	-40 °C	-40 °C	-	-

**FMR50**, Position 7, 8 (Antenna) = BN, BR

**Position 3 (Power Supply; Output) = C (TRC [04])**

Position 5 (Housing) = A													
Power Supply; Output	Temperature class	P 1		P 2		P 3		P 4		P 5		P 6	
		T <sub>p</sub>	T <sub>a</sub>	T <sub>p</sub>	T <sub>a</sub>	T <sub>p</sub>	T <sub>a</sub>	T <sub>p</sub>	T <sub>a</sub>	T <sub>p</sub>	T <sub>a</sub>	T <sub>p</sub>	T <sub>a</sub>
1 channel used	T6 ( 85 °C)	-40 °C	60 °C	60 °C	60 °C	80 °C	55 °C	80 °C	-40 °C	-40 °C	-40 °C	-	-
2 channels used	T6 ( 85 °C)	-40 °C	53 °C	53 °C	53 °C	80 °C	48 °C	80 °C	-40 °C	-40 °C	-40 °C	-	-

Position 5 (Housing) = C													
Power Supply; Output	Temperature class	P 1		P 2		P 3		P 4		P 5		P 6	
		T <sub>p</sub>	T <sub>a</sub>	T <sub>p</sub>	T <sub>a</sub>	T <sub>p</sub>	T <sub>a</sub>	T <sub>p</sub>	T <sub>a</sub>	T <sub>p</sub>	T <sub>a</sub>	T <sub>p</sub>	T <sub>a</sub>
1 channel used	T6 ( 85 °C)	-40 °C	60 °C	60 °C	60 °C	80 °C	58 °C	80 °C	-40 °C	-40 °C	-40 °C	-	-
2 channels used	T6 ( 85 °C)	-40 °C	54 °C	54 °C	54 °C	80 °C	52 °C	80 °C	-40 °C	-40 °C	-40 °C	-	-

## Antenna and electronics housing: Zone 1

## FMR51

## Position 3 (Power Supply; Output) = C (TRC [04])

Position 5 (Housing) = A													
Power Supply; Output	Temperature class	P 1		P 2		P 3		P 4		P 5		P 6	
		T <sub>p</sub>	T <sub>a</sub>	T <sub>p</sub>	T <sub>a</sub>	T <sub>p</sub>	T <sub>a</sub>	T <sub>p</sub>	T <sub>a</sub>	T <sub>p</sub>	T <sub>a</sub>	T <sub>p</sub>	T <sub>a</sub>
1 channel used	T6 ( 85 °C)	-40 °C	60 °C	60 °C	60 °C	85 °C	49 °C	85 °C	-40 °C	-40 °C	-40 °C	-	-
	T5 (100 °C)	-40 °C	75 °C	75 °C	75 °C	100 °C	64 °C	100 °C	-40 °C	-40 °C	-40 °C	-	-
	T4 (135 °C)	-40 °C	80 °C	81 °C	80 °C	135 °C	63 °C	135 °C	-40 °C	-40 °C	-40 °C	-	-
	T3 (200 °C)	-40 °C	80 °C	81 °C	80 °C	150 °C	56 °C	150 °C	-40 °C	-40 °C	-40 °C	-	-
2 channels used	T6 ( 85 °C)	-40 °C	53 °C	53 °C	53 °C	85 °C	45 °C	85 °C	-40 °C	-40 °C	-40 °C	-	-
	T5 (100 °C)	-40 °C	68 °C	68 °C	68 °C	100 °C	60 °C	100 °C	-40 °C	-40 °C	-40 °C	-	-
	T4 (135 °C)	-40 °C	73 °C	73 °C	73 °C	135 °C	58 °C	135 °C	-40 °C	-40 °C	-40 °C	-	-
	T3 (200 °C)	-40 °C	73 °C	73 °C	73 °C	150 °C	54 °C	150 °C	-40 °C	-40 °C	-40 °C	-	-

Position 5 (Housing) = B													
Power Supply; Output	Temperature class	P 1		P 2		P 3		P 4		P 5		P 6	
		T <sub>p</sub>	T <sub>a</sub>	T <sub>p</sub>	T <sub>a</sub>	T <sub>p</sub>	T <sub>a</sub>	T <sub>p</sub>	T <sub>a</sub>	T <sub>p</sub>	T <sub>a</sub>	T <sub>p</sub>	T <sub>a</sub>
1 channel used	T6 ( 85 °C)	-40 °C	60 °C	60 °C	60 °C	85 °C	54 °C	85 °C	-40 °C	-40 °C	-40 °C	-	-
	T5 (100 °C)	-40 °C	75 °C	75 °C	75 °C	100 °C	69 °C	100 °C	-40 °C	-40 °C	-40 °C	-	-
	T4 (135 °C)	-40 °C	80 °C	82 °C	80 °C	135 °C	70 °C	135 °C	-40 °C	-40 °C	-40 °C	-	-
	T3 (200 °C)	-40 °C	80 °C	82 °C	80 °C	150 °C	67 °C	150 °C	-40 °C	-40 °C	-40 °C	-	-
2 channels used	T6 ( 85 °C)	-40 °C	54 °C	54 °C	54 °C	85 °C	48 °C	85 °C	-40 °C	-40 °C	-40 °C	-	-
	T5 (100 °C)	-40 °C	69 °C	69 °C	69 °C	100 °C	63 °C	100 °C	-40 °C	-40 °C	-40 °C	-	-
	T4 (135 °C)	-40 °C	78 °C	78 °C	78 °C	135 °C	66 °C	135 °C	-40 °C	-40 °C	-40 °C	-	-
	T3 (200 °C)	-40 °C	78 °C	78 °C	78 °C	150 °C	63 °C	150 °C	-40 °C	-40 °C	-40 °C	-	-

Position 5 (Housing) = C													
Power Supply; Output	Temperature class	P 1		P 2		P 3		P 4		P 5		P 6	
		T <sub>p</sub>	T <sub>a</sub>	T <sub>p</sub>	T <sub>a</sub>	T <sub>p</sub>	T <sub>a</sub>	T <sub>p</sub>	T <sub>a</sub>	T <sub>p</sub>	T <sub>a</sub>	T <sub>p</sub>	T <sub>a</sub>
1 channel used	T6 ( 85 °C)	-40 °C	60 °C	60 °C	60 °C	85 °C	55 °C	85 °C	-40 °C	-40 °C	-40 °C	-	-
	T5 (100 °C)	-40 °C	75 °C	75 °C	75 °C	100 °C	70 °C	100 °C	-40 °C	-40 °C	-40 °C	-	-
	T4 (135 °C)	-40 °C	80 °C	82 °C	80 °C	135 °C	72 °C	135 °C	-40 °C	-40 °C	-40 °C	-	-
	T3 (200 °C)	-40 °C	80 °C	82 °C	80 °C	150 °C	70 °C	150 °C	-40 °C	-40 °C	-40 °C	-	-
2 channels used	T6 ( 85 °C)	-40 °C	54 °C	54 °C	54 °C	85 °C	49 °C	85 °C	-40 °C	-40 °C	-40 °C	-	-
	T5 (100 °C)	-40 °C	69 °C	69 °C	69 °C	100 °C	64 °C	100 °C	-40 °C	-40 °C	-40 °C	-	-
	T4 (135 °C)	-40 °C	78 °C	78 °C	78 °C	135 °C	68 °C	135 °C	-40 °C	-40 °C	-40 °C	-	-
	T3 (200 °C)	-40 °C	78 °C	78 °C	78 °C	150 °C	66 °C	150 °C	-40 °C	-40 °C	-40 °C	-	-

**Antenna and electronics housing: Zone 1**

**FMR51**, Position 9, 10 (Seal) = D3

**Position 3 (Power Supply; Output) = C (TRC [04])**

Position 5 (Housing) = A													
Power Supply; Output	Temperature class	P 1		P 2		P 3		P 4		P 5		P 6	
		T <sub>p</sub>	T <sub>a</sub>	T <sub>p</sub>	T <sub>a</sub>	T <sub>p</sub>	T <sub>a</sub>	T <sub>p</sub>	T <sub>a</sub>	T <sub>p</sub>	T <sub>a</sub>	T <sub>p</sub>	T <sub>a</sub>
1 channel used	T6 ( 85 °C)	-40 °C	60 °C	60 °C	60 °C	85 °C	54 °C	85 °C	-40 °C	-40 °C	-40 °C	-	-
	T5 (100 °C)	-40 °C	75 °C	75 °C	75 °C	100 °C	69 °C	100 °C	-40 °C	-40 °C	-40 °C	-	-
	T4 (135 °C)	-40 °C	80 °C	81 °C	80 °C	135 °C	72 °C	135 °C	-40 °C	-40 °C	-40 °C	-	-
	T3 (200 °C)	-40 °C	80 °C	81 °C	80 °C	200 °C	56 °C	200 °C	-40 °C	-40 °C	-40 °C	-	-
	T2 (300 °C)	-40 °C	80 °C	81 °C	80 °C	250 °C	44 °C	250 °C	-40 °C	-40 °C	-40 °C	-	-
2 channels used	T6 ( 85 °C)	-40 °C	53 °C	53 °C	53 °C	85 °C	48 °C	85 °C	-40 °C	-40 °C	-40 °C	-	-
	T5 (100 °C)	-40 °C	68 °C	68 °C	68 °C	100 °C	63 °C	100 °C	-40 °C	-40 °C	-40 °C	-	-
	T4 (135 °C)	-40 °C	73 °C	73 °C	73 °C	135 °C	64 °C	135 °C	-40 °C	-40 °C	-40 °C	-	-
	T3 (200 °C)	-40 °C	73 °C	73 °C	73 °C	200 °C	54 °C	200 °C	-40 °C	-40 °C	-40 °C	-	-
	T2 (300 °C)	-40 °C	73 °C	73 °C	73 °C	250 °C	44 °C	250 °C	-40 °C	-40 °C	-40 °C	-	-

Position 5 (Housing) = B													
Power Supply; Output	Temperature class	P 1		P 2		P 3		P 4		P 5		P 6	
		T <sub>p</sub>	T <sub>a</sub>	T <sub>p</sub>	T <sub>a</sub>	T <sub>p</sub>	T <sub>a</sub>	T <sub>p</sub>	T <sub>a</sub>	T <sub>p</sub>	T <sub>a</sub>	T <sub>p</sub>	T <sub>a</sub>
1 channel used	T6 ( 85 °C)	-40 °C	60 °C	60 °C	60 °C	85 °C	57 °C	85 °C	-40 °C	-40 °C	-40 °C	-	-
	T5 (100 °C)	-40 °C	75 °C	75 °C	75 °C	100 °C	72 °C	100 °C	-40 °C	-40 °C	-40 °C	-	-
	T4 (135 °C)	-40 °C	80 °C	82 °C	80 °C	135 °C	76 °C	135 °C	-40 °C	-40 °C	-40 °C	-	-
	T3 (200 °C)	-40 °C	80 °C	82 °C	80 °C	200 °C	69 °C	200 °C	-40 °C	-40 °C	-40 °C	-	-
	T2 (300 °C)	-40 °C	80 °C	82 °C	80 °C	250 °C	64 °C	250 °C	-40 °C	-40 °C	-40 °C	-	-
2 channels used	T6 ( 85 °C)	-40 °C	54 °C	54 °C	54 °C	85 °C	51 °C	85 °C	-40 °C	-40 °C	-40 °C	-	-
	T5 (100 °C)	-40 °C	69 °C	69 °C	69 °C	100 °C	66 °C	100 °C	-40 °C	-40 °C	-40 °C	-	-
	T4 (135 °C)	-40 °C	78 °C	78 °C	78 °C	135 °C	72 °C	135 °C	-40 °C	-40 °C	-40 °C	-	-
	T3 (200 °C)	-40 °C	78 °C	78 °C	78 °C	200 °C	65 °C	200 °C	-40 °C	-40 °C	-40 °C	-	-
	T2 (300 °C)	-40 °C	78 °C	78 °C	78 °C	250 °C	60 °C	250 °C	-40 °C	-40 °C	-40 °C	-	-

Position 5 (Housing) = C													
Power Supply; Output	Temperature class	P 1		P 2		P 3		P 4		P 5		P 6	
		T <sub>p</sub>	T <sub>a</sub>	T <sub>p</sub>	T <sub>a</sub>	T <sub>p</sub>	T <sub>a</sub>	T <sub>p</sub>	T <sub>a</sub>	T <sub>p</sub>	T <sub>a</sub>	T <sub>p</sub>	T <sub>a</sub>
1 channel used	T6 ( 85 °C)	-40 °C	60 °C	60 °C	60 °C	85 °C	58 °C	85 °C	-40 °C	-40 °C	-40 °C	-	-
	T5 (100 °C)	-40 °C	75 °C	75 °C	75 °C	100 °C	73 °C	100 °C	-40 °C	-40 °C	-40 °C	-	-
	T4 (135 °C)	-40 °C	80 °C	82 °C	80 °C	135 °C	77 °C	135 °C	-40 °C	-40 °C	-40 °C	-	-
	T3 (200 °C)	-40 °C	80 °C	82 °C	80 °C	200 °C	72 °C	200 °C	-40 °C	-40 °C	-40 °C	-	-
	T2 (300 °C)	-40 °C	80 °C	82 °C	80 °C	250 °C	68 °C	250 °C	-40 °C	-40 °C	-40 °C	-	-
2 channels used	T6 ( 85 °C)	-40 °C	54 °C	54 °C	54 °C	85 °C	52 °C	85 °C	-40 °C	-40 °C	-40 °C	-	-
	T5 (100 °C)	-40 °C	69 °C	69 °C	69 °C	100 °C	67 °C	100 °C	-40 °C	-40 °C	-40 °C	-	-
	T4 (135 °C)	-40 °C	78 °C	78 °C	78 °C	135 °C	73 °C	135 °C	-40 °C	-40 °C	-40 °C	-	-
	T3 (200 °C)	-40 °C	78 °C	78 °C	78 °C	200 °C	68 °C	200 °C	-40 °C	-40 °C	-40 °C	-	-
	T2 (300 °C)	-40 °C	78 °C	78 °C	78 °C	250 °C	64 °C	250 °C	-40 °C	-40 °C	-40 °C	-	-

### Antenna and electronics housing: Zone 1

FMR51, Position 9, 10 (Seal) = D2

Position 3 (Power Supply; Output) = C (TRC [04])

Position 5 (Housing) = A													
Power Supply; Output	Temperature class	P 1		P 2		P 3		P 4		P 5		P 6	
		T <sub>p</sub>	T <sub>a</sub>	T <sub>p</sub>	T <sub>a</sub>	T <sub>p</sub>	T <sub>a</sub>	T <sub>p</sub>	T <sub>a</sub>	T <sub>p</sub>	T <sub>a</sub>	T <sub>p</sub>	T <sub>a</sub>
1 channel used	T6 ( 85 °C)	-196 °C	60 °C	60 °C	60 °C	85 °C	52 °C	85 °C	-40 °C	-40 °C	-40 °C	-196 °C	9 °C
	T5 (100 °C)	-196 °C	75 °C	75 °C	75 °C	100 °C	67 °C	100 °C	-40 °C	-40 °C	-40 °C	-196 °C	9 °C
	T4 (135 °C)	-196 °C	80 °C	81 °C	80 °C	135 °C	69 °C	135 °C	-40 °C	-40 °C	-40 °C	-196 °C	9 °C
	T3 (200 °C)	-196 °C	80 °C	81 °C	80 °C	200 °C	49 °C	200 °C	-40 °C	-40 °C	-40 °C	-196 °C	9 °C
2 channels used	T6 ( 85 °C)	-196 °C	53 °C	53 °C	53 °C	85 °C	47 °C	85 °C	-40 °C	-40 °C	-40 °C	-196 °C	9 °C
	T5 (100 °C)	-196 °C	68 °C	68 °C	68 °C	100 °C	62 °C	100 °C	-40 °C	-40 °C	-40 °C	-196 °C	9 °C
	T4 (135 °C)	-196 °C	73 °C	73 °C	73 °C	135 °C	62 °C	135 °C	-40 °C	-40 °C	-40 °C	-196 °C	9 °C
	T3 (200 °C)	-196 °C	73 °C	73 °C	73 °C	200 °C	49 °C	200 °C	-40 °C	-40 °C	-40 °C	-196 °C	9 °C



Position 5 (Housing) = B													
Power Supply; Output	Temperature class	P 1		P 2		P 3		P 4		P 5		P 6	
		T <sub>p</sub>	T <sub>a</sub>	T <sub>p</sub>	T <sub>a</sub>	T <sub>p</sub>	T <sub>a</sub>	T <sub>p</sub>	T <sub>a</sub>	T <sub>p</sub>	T <sub>a</sub>	T <sub>p</sub>	T <sub>a</sub>
1 channel used	T6 ( 85 °C)	-196 °C	60 °C	60 °C	60 °C	85 °C	56 °C	85 °C	-40 °C	-40 °C	-40 °C	-196 °C	-15 °C
	T5 (100 °C)	-196 °C	75 °C	75 °C	75 °C	100 °C	71 °C	100 °C	-40 °C	-40 °C	-40 °C	-196 °C	-15 °C
	T4 (135 °C)	-196 °C	80 °C	82 °C	80 °C	135 °C	74 °C	135 °C	-40 °C	-40 °C	-40 °C	-196 °C	-15 °C
	T3 (200 °C)	-196 °C	80 °C	82 °C	80 °C	200 °C	65 °C	200 °C	-40 °C	-40 °C	-40 °C	-196 °C	-15 °C
	T2 (300 °C)	-196 °C	80 °C	82 °C	80 °C	300 °C	50 °C	300 °C	-40 °C	-40 °C	-40 °C	-196 °C	-15 °C
2 channels used	T6 ( 85 °C)	-196 °C	54 °C	54 °C	54 °C	85 °C	50 °C	85 °C	-40 °C	-40 °C	-40 °C	-196 °C	-15 °C
	T5 (100 °C)	-196 °C	69 °C	69 °C	69 °C	100 °C	65 °C	100 °C	-40 °C	-40 °C	-40 °C	-196 °C	-15 °C
	T4 (135 °C)	-196 °C	78 °C	78 °C	78 °C	135 °C	70 °C	135 °C	-40 °C	-40 °C	-40 °C	-196 °C	-15 °C
	T3 (200 °C)	-196 °C	78 °C	78 °C	78 °C	200 °C	61 °C	200 °C	-40 °C	-40 °C	-40 °C	-196 °C	-15 °C
	T2 (300 °C)	-196 °C	78 °C	78 °C	78 °C	300 °C	48 °C	300 °C	-40 °C	-40 °C	-40 °C	-196 °C	-15 °C

Position 5 (Housing) = C													
Power Supply; Output	Temperature class	P 1		P 2		P 3		P 4		P 5		P 6	
		T <sub>p</sub>	T <sub>a</sub>	T <sub>p</sub>	T <sub>a</sub>	T <sub>p</sub>	T <sub>a</sub>	T <sub>p</sub>	T <sub>a</sub>	T <sub>p</sub>	T <sub>a</sub>	T <sub>p</sub>	T <sub>a</sub>
1 channel used	T6 ( 85 °C)	-196 °C	60 °C	60 °C	60 °C	85 °C	57 °C	85 °C	-40 °C	-40 °C	-40 °C	-196 °C	-20 °C
	T5 (100 °C)	-196 °C	75 °C	75 °C	75 °C	100 °C	72 °C	100 °C	-40 °C	-40 °C	-40 °C	-196 °C	-20 °C
	T4 (135 °C)	-196 °C	80 °C	82 °C	80 °C	135 °C	76 °C	135 °C	-40 °C	-40 °C	-40 °C	-196 °C	-20 °C
	T3 (200 °C)	-196 °C	80 °C	82 °C	80 °C	200 °C	69 °C	200 °C	-40 °C	-40 °C	-40 °C	-196 °C	-20 °C
	T2 (300 °C)	-196 °C	80 °C	82 °C	80 °C	300 °C	58 °C	300 °C	-40 °C	-40 °C	-40 °C	-196 °C	-20 °C
	T1 (450 °C) *1	-196 °C	80 °C	82 °C	80 °C	450 °C	39 °C	450 °C	-40 °C	-40 °C	-40 °C	-196 °C	-20 °C
2 channels used	T6 ( 85 °C)	-196 °C	54 °C	54 °C	54 °C	85 °C	51 °C	85 °C	-40 °C	-40 °C	-40 °C	-196 °C	-20 °C
	T5 (100 °C)	-196 °C	69 °C	69 °C	69 °C	100 °C	66 °C	100 °C	-40 °C	-40 °C	-40 °C	-196 °C	-20 °C
	T4 (135 °C)	-196 °C	78 °C	78 °C	78 °C	135 °C	72 °C	135 °C	-40 °C	-40 °C	-40 °C	-196 °C	-20 °C
	T3 (200 °C)	-196 °C	78 °C	78 °C	78 °C	200 °C	65 °C	200 °C	-40 °C	-40 °C	-40 °C	-196 °C	-20 °C
	T2 (300 °C)	-196 °C	78 °C	78 °C	78 °C	300 °C	54 °C	300 °C	-40 °C	-40 °C	-40 °C	-196 °C	-20 °C
	T1 (450 °C) *1	-196 °C	78 °C	78 °C	78 °C	450 °C	38 °C	450 °C	-40 °C	-40 °C	-40 °C	-196 °C	-20 °C

## Antenna and electronics housing: Zone 1

FMR52, Position 7, 8 (Antenna) = BO

Position 3 (Power Supply; Output) = C (TRC [04])

Position 5 (Housing) = A													
Power Supply; Output	Temperature class	P 1		P 2		P 3		P 4		P 5		P 6	
		T <sub>p</sub>	T <sub>a</sub>	T <sub>p</sub>	T <sub>a</sub>	T <sub>p</sub>	T <sub>a</sub>	T <sub>p</sub>	T <sub>a</sub>	T <sub>p</sub>	T <sub>a</sub>	T <sub>p</sub>	T <sub>a</sub>
1 channel used	T6 ( 85 °C)	-40 °C	60 °C	60 °C	60 °C	85 °C	51 °C	85 °C	-40 °C	-40 °C	-40 °C	-	-
	T5 (100 °C)	-40 °C	75 °C	75 °C	75 °C	100 °C	66 °C	100 °C	-40 °C	-40 °C	-40 °C	-	-
	T4 (135 °C)	-40 °C	80 °C	81 °C	80 °C	135 °C	66 °C	135 °C	-40 °C	-40 °C	-40 °C	-	-
	T3 (200 °C)	-40 °C	80 °C	81 °C	80 °C	200 °C	42 °C	200 °C	-40 °C	-40 °C	-40 °C	-	-
2 channels used	T6 ( 85 °C)	-40 °C	53 °C	53 °C	53 °C	85 °C	46 °C	85 °C	-40 °C	-40 °C	-40 °C	-	-
	T5 (100 °C)	-40 °C	68 °C	68 °C	68 °C	100 °C	61 °C	100 °C	-40 °C	-40 °C	-40 °C	-	-
	T4 (135 °C)	-40 °C	73 °C	73 °C	73 °C	135 °C	60 °C	135 °C	-40 °C	-40 °C	-40 °C	-	-
	T3 (200 °C)	-40 °C	73 °C	73 °C	73 °C	200 °C	42 °C	200 °C	-40 °C	-40 °C	-40 °C	-	-

Position 5 (Housing) = B													
Power Supply; Output	Temperature class	P 1		P 2		P 3		P 4		P 5		P 6	
		T <sub>p</sub>	T <sub>a</sub>	T <sub>p</sub>	T <sub>a</sub>	T <sub>p</sub>	T <sub>a</sub>	T <sub>p</sub>	T <sub>a</sub>	T <sub>p</sub>	T <sub>a</sub>	T <sub>p</sub>	T <sub>a</sub>
1 channel used	T6 ( 85 °C)	-40 °C	60 °C	60 °C	60 °C	85 °C	55 °C	85 °C	-40 °C	-40 °C	-40 °C	-	-
	T5 (100 °C)	-40 °C	75 °C	75 °C	75 °C	100 °C	70 °C	100 °C	-40 °C	-40 °C	-40 °C	-	-
	T4 (135 °C)	-40 °C	80 °C	82 °C	80 °C	135 °C	73 °C	135 °C	-40 °C	-40 °C	-40 °C	-	-
	T3 (200 °C)	-40 °C	80 °C	82 °C	80 °C	200 °C	61 °C	200 °C	-40 °C	-40 °C	-40 °C	-	-
2 channels used	T6 ( 85 °C)	-40 °C	54 °C	54 °C	54 °C	85 °C	49 °C	85 °C	-40 °C	-40 °C	-40 °C	-	-
	T5 (100 °C)	-40 °C	69 °C	69 °C	69 °C	100 °C	64 °C	100 °C	-40 °C	-40 °C	-40 °C	-	-
	T4 (135 °C)	-40 °C	78 °C	78 °C	78 °C	135 °C	68 °C	135 °C	-40 °C	-40 °C	-40 °C	-	-
	T3 (200 °C)	-40 °C	78 °C	78 °C	78 °C	200 °C	57 °C	200 °C	-40 °C	-40 °C	-40 °C	-	-

Position 5 (Housing) = C													
Power Supply; Output	Temperature class	P 1		P 2		P 3		P 4		P 5		P 6	
		T <sub>p</sub>	T <sub>a</sub>	T <sub>p</sub>	T <sub>a</sub>	T <sub>p</sub>	T <sub>a</sub>	T <sub>p</sub>	T <sub>a</sub>	T <sub>p</sub>	T <sub>a</sub>	T <sub>p</sub>	T <sub>a</sub>
1 channel used	T6 ( 85 °C)	-40 °C	60 °C	60 °C	60 °C	85 °C	56 °C	85 °C	-40 °C	-40 °C	-40 °C	-	-
	T5 (100 °C)	-40 °C	75 °C	75 °C	75 °C	100 °C	71 °C	100 °C	-40 °C	-40 °C	-40 °C	-	-
	T4 (135 °C)	-40 °C	80 °C	82 °C	80 °C	135 °C	74 °C	135 °C	-40 °C	-40 °C	-40 °C	-	-
	T3 (200 °C)	-40 °C	80 °C	82 °C	80 °C	200 °C	65 °C	200 °C	-40 °C	-40 °C	-40 °C	-	-
2 channels used	T6 ( 85 °C)	-40 °C	54 °C	54 °C	54 °C	85 °C	50 °C	85 °C	-40 °C	-40 °C	-40 °C	-	-
	T5 (100 °C)	-40 °C	69 °C	69 °C	69 °C	100 °C	65 °C	100 °C	-40 °C	-40 °C	-40 °C	-	-
	T4 (135 °C)	-40 °C	78 °C	78 °C	78 °C	135 °C	70 °C	135 °C	-40 °C	-40 °C	-40 °C	-	-
	T3 (200 °C)	-40 °C	78 °C	78 °C	78 °C	200 °C	61 °C	200 °C	-40 °C	-40 °C	-40 °C	-	-

**Antenna and electronics housing: Zone 1**

**FMR52**, Position 7, 8 (Antenna) = BP

**Position 3 (Power Supply; Output) = C (TRC [04])**

Position 5 (Housing) = A													
Power Supply; Output	Temperature class	P 1		P 2		P 3		P 4		P 5		P 6	
		T <sub>p</sub>	T <sub>a</sub>	T <sub>p</sub>	T <sub>a</sub>	T <sub>p</sub>	T <sub>a</sub>	T <sub>p</sub>	T <sub>a</sub>	T <sub>p</sub>	T <sub>a</sub>	T <sub>p</sub>	T <sub>a</sub>
1 channel used	T6 ( 85 °C)	-40 °C	60 °C	60 °C	60 °C	85 °C	49 °C	85 °C	-40 °C	-40 °C	-40 °C	-	-
	T5 (100 °C)	-40 °C	75 °C	75 °C	75 °C	100 °C	64 °C	100 °C	-40 °C	-40 °C	-40 °C	-	-
	T4 (135 °C)	-40 °C	80 °C	81 °C	80 °C	135 °C	64 °C	135 °C	-40 °C	-40 °C	-40 °C	-	-
	T3 (200 °C)	-40 °C	80 °C	81 °C	80 °C	200 °C	36 °C	200 °C	-40 °C	-40 °C	-40 °C	-	-
2 channels used	T6 ( 85 °C)	-40 °C	53 °C	53 °C	53 °C	85 °C	45 °C	85 °C	-40 °C	-40 °C	-40 °C	-	-
	T5 (100 °C)	-40 °C	68 °C	68 °C	68 °C	100 °C	60 °C	100 °C	-40 °C	-40 °C	-40 °C	-	-
	T4 (135 °C)	-40 °C	73 °C	73 °C	73 °C	135 °C	58 °C	135 °C	-40 °C	-40 °C	-40 °C	-	-
	T3 (200 °C)	-40 °C	73 °C	73 °C	73 °C	200 °C	36 °C	200 °C	-40 °C	-40 °C	-40 °C	-	-

Position 5 (Housing) = B													
Power Supply; Output	Temperature class	P 1		P 2		P 3		P 4		P 5		P 6	
		T <sub>p</sub>	T <sub>a</sub>	T <sub>p</sub>	T <sub>a</sub>	T <sub>p</sub>	T <sub>a</sub>	T <sub>p</sub>	T <sub>a</sub>	T <sub>p</sub>	T <sub>a</sub>	T <sub>p</sub>	T <sub>a</sub>
1 channel used	T6 ( 85 °C)	-40 °C	60 °C	60 °C	60 °C	85 °C	54 °C	85 °C	-40 °C	-40 °C	-40 °C	-	-
	T5 (100 °C)	-40 °C	75 °C	75 °C	75 °C	100 °C	69 °C	100 °C	-40 °C	-40 °C	-40 °C	-	-
	T4 (135 °C)	-40 °C	80 °C	82 °C	80 °C	135 °C	71 °C	135 °C	-40 °C	-40 °C	-40 °C	-	-
	T3 (200 °C)	-40 °C	80 °C	82 °C	80 °C	200 °C	57 °C	200 °C	-40 °C	-40 °C	-40 °C	-	-
2 channels used	T6 ( 85 °C)	-40 °C	54 °C	54 °C	54 °C	85 °C	48 °C	85 °C	-40 °C	-40 °C	-40 °C	-	-
	T5 (100 °C)	-40 °C	69 °C	69 °C	69 °C	100 °C	63 °C	100 °C	-40 °C	-40 °C	-40 °C	-	-
	T4 (135 °C)	-40 °C	78 °C	78 °C	78 °C	135 °C	66 °C	135 °C	-40 °C	-40 °C	-40 °C	-	-
	T3 (200 °C)	-40 °C	78 °C	78 °C	78 °C	200 °C	53 °C	200 °C	-40 °C	-40 °C	-40 °C	-	-

Position 5 (Housing) = C													
Power Supply; Output	Temperature class	P 1		P 2		P 3		P 4		P 5		P 6	
		T <sub>p</sub>	T <sub>a</sub>	T <sub>p</sub>	T <sub>a</sub>	T <sub>p</sub>	T <sub>a</sub>	T <sub>p</sub>	T <sub>a</sub>	T <sub>p</sub>	T <sub>a</sub>	T <sub>p</sub>	T <sub>a</sub>
1 channel used	T6 ( 85 °C)	-40 °C	60 °C	60 °C	60 °C	85 °C	55 °C	85 °C	-40 °C	-40 °C	-40 °C	-	-
	T5 (100 °C)	-40 °C	75 °C	75 °C	75 °C	100 °C	70 °C	100 °C	-40 °C	-40 °C	-40 °C	-	-
	T4 (135 °C)	-40 °C	80 °C	82 °C	80 °C	135 °C	73 °C	135 °C	-40 °C	-40 °C	-40 °C	-	-
	T3 (200 °C)	-40 °C	80 °C	82 °C	80 °C	200 °C	62 °C	200 °C	-40 °C	-40 °C	-40 °C	-	-
2 channels used	T6 ( 85 °C)	-40 °C	54 °C	54 °C	54 °C	85 °C	49 °C	85 °C	-40 °C	-40 °C	-40 °C	-	-
	T5 (100 °C)	-40 °C	69 °C	69 °C	69 °C	100 °C	64 °C	100 °C	-40 °C	-40 °C	-40 °C	-	-
	T4 (135 °C)	-40 °C	78 °C	78 °C	78 °C	135 °C	69 °C	135 °C	-40 °C	-40 °C	-40 °C	-	-
	T3 (200 °C)	-40 °C	78 °C	78 °C	78 °C	200 °C	58 °C	200 °C	-40 °C	-40 °C	-40 °C	-	-

### Antenna and electronics housing: Zone 1

FMR53, Position 11-13 (Process Connection) = RxF

**Position 3 (Power Supply; Output) = C (TRC [04])**

Position 5 (Housing) = A													
Power Supply; Output	Temperature class	P 1		P 2		P 3		P 4		P 5		P 6	
		T <sub>p</sub>	T <sub>a</sub>	T <sub>p</sub>	T <sub>a</sub>	T <sub>p</sub>	T <sub>a</sub>	T <sub>p</sub>	T <sub>a</sub>	T <sub>p</sub>	T <sub>a</sub>	T <sub>p</sub>	T <sub>a</sub>
1 channel used	T6 ( 85 °C)	-40 °C	60 °C	60 °C	60 °C	80 °C	56 °C	80 °C	-40 °C	-40 °C	-40 °C	-	-
2 channels used	T6 ( 85 °C)	-40 °C	53 °C	53 °C	53 °C	80 °C	49 °C	80 °C	-40 °C	-40 °C	-40 °C	-	-

Position 5 (Housing) = B													
Power Supply; Output	Temperature class	P 1		P 2		P 3		P 4		P 5		P 6	
		T <sub>p</sub>	T <sub>a</sub>	T <sub>p</sub>	T <sub>a</sub>	T <sub>p</sub>	T <sub>a</sub>	T <sub>p</sub>	T <sub>a</sub>	T <sub>p</sub>	T <sub>a</sub>	T <sub>p</sub>	T <sub>a</sub>
1 channel used	T6 ( 85 °C)	-40 °C	60 °C	60 °C	60 °C	80 °C	58 °C	80 °C	-40 °C	-40 °C	-40 °C	-	-
2 channels used	T6 ( 85 °C)	-40 °C	54 °C	54 °C	54 °C	80 °C	52 °C	80 °C	-40 °C	-40 °C	-40 °C	-	-

Position 5 (Housing) = C													
Power Supply; Output	Temperature class	P 1		P 2		P 3		P 4		P 5		P 6	
		T <sub>p</sub>	T <sub>a</sub>	T <sub>p</sub>	T <sub>a</sub>	T <sub>p</sub>	T <sub>a</sub>	T <sub>p</sub>	T <sub>a</sub>	T <sub>p</sub>	T <sub>a</sub>	T <sub>p</sub>	T <sub>a</sub>
1 channel used	T6 ( 85 °C)	-40 °C	60 °C	60 °C	60 °C	80 °C	58 °C	80 °C	-40 °C	-40 °C	-40 °C	-	-
2 channels used	T6 ( 85 °C)	-40 °C	54 °C	54 °C	54 °C	80 °C	53 °C	80 °C	-40 °C	-40 °C	-40 °C	-	-

Antenna and electronics housing: Zone 1

FMR53

Position 3 (Power Supply; Output) = C (TRC [04])

Position 5 (Housing) = A													
Power Supply; Output	Temperature class	P 1		P 2		P 3		P 4		P 5		P 6	
		T <sub>p</sub>	T <sub>a</sub>	T <sub>p</sub>	T <sub>a</sub>	T <sub>p</sub>	T <sub>a</sub>	T <sub>p</sub>	T <sub>a</sub>	T <sub>p</sub>	T <sub>a</sub>	T <sub>p</sub>	T <sub>a</sub>
1 channel used	T6 ( 85 °C)	-40 °C	60 °C	60 °C	60 °C	85 °C	48 °C	85 °C	-40 °C	-40 °C	-40 °C	-	-
	T5 (100 °C)	-40 °C	75 °C	75 °C	75 °C	100 °C	63 °C	100 °C	-40 °C	-40 °C	-40 °C	-	-
	T4 (135 °C)	-40 °C	80 °C	81 °C	80 °C	135 °C	62 °C	135 °C	-40 °C	-40 °C	-40 °C	-	-
	T3 (200 °C)	-40 °C	80 °C	81 °C	80 °C	150 °C	55 °C	150 °C	-40 °C	-40 °C	-40 °C	-	-
2 channels used	T6 ( 85 °C)	-40 °C	53 °C	53 °C	53 °C	85 °C	44 °C	85 °C	-40 °C	-40 °C	-40 °C	-	-
	T5 (100 °C)	-40 °C	68 °C	68 °C	68 °C	100 °C	59 °C	100 °C	-40 °C	-40 °C	-40 °C	-	-
	T4 (135 °C)	-40 °C	73 °C	73 °C	73 °C	135 °C	57 °C	135 °C	-40 °C	-40 °C	-40 °C	-	-
	T3 (200 °C)	-40 °C	73 °C	73 °C	73 °C	150 °C	53 °C	150 °C	-40 °C	-40 °C	-40 °C	-	-

Position 5 (Housing) = B													
Power Supply; Output	Temperature class	P 1		P 2		P 3		P 4		P 5		P 6	
		T <sub>p</sub>	T <sub>a</sub>	T <sub>p</sub>	T <sub>a</sub>	T <sub>p</sub>	T <sub>a</sub>	T <sub>p</sub>	T <sub>a</sub>	T <sub>p</sub>	T <sub>a</sub>	T <sub>p</sub>	T <sub>a</sub>
1 channel used	T6 ( 85 °C)	-40 °C	60 °C	60 °C	60 °C	85 °C	53 °C	85 °C	-40 °C	-40 °C	-40 °C	-	-
	T5 (100 °C)	-40 °C	75 °C	75 °C	75 °C	100 °C	68 °C	100 °C	-40 °C	-40 °C	-40 °C	-	-
	T4 (135 °C)	-40 °C	80 °C	82 °C	80 °C	135 °C	69 °C	135 °C	-40 °C	-40 °C	-40 °C	-	-
	T3 (200 °C)	-40 °C	80 °C	82 °C	80 °C	150 °C	66 °C	150 °C	-40 °C	-40 °C	-40 °C	-	-
2 channels used	T6 ( 85 °C)	-40 °C	54 °C	54 °C	54 °C	85 °C	47 °C	85 °C	-40 °C	-40 °C	-40 °C	-	-
	T5 (100 °C)	-40 °C	69 °C	69 °C	69 °C	100 °C	62 °C	100 °C	-40 °C	-40 °C	-40 °C	-	-
	T4 (135 °C)	-40 °C	78 °C	78 °C	78 °C	135 °C	65 °C	135 °C	-40 °C	-40 °C	-40 °C	-	-
	T3 (200 °C)	-40 °C	78 °C	78 °C	78 °C	150 °C	61 °C	150 °C	-40 °C	-40 °C	-40 °C	-	-

Position 5 (Housing) = C													
Power Supply; Output	Temperature class	P 1		P 2		P 3		P 4		P 5		P 6	
		T <sub>p</sub>	T <sub>a</sub>	T <sub>p</sub>	T <sub>a</sub>	T <sub>p</sub>	T <sub>a</sub>	T <sub>p</sub>	T <sub>a</sub>	T <sub>p</sub>	T <sub>a</sub>	T <sub>p</sub>	T <sub>a</sub>
1 channel used	T6 ( 85 °C)	-40 °C	60 °C	60 °C	60 °C	85 °C	54 °C	85 °C	-40 °C	-40 °C	-40 °C	-	-
	T5 (100 °C)	-40 °C	75 °C	75 °C	75 °C	100 °C	70 °C	100 °C	-40 °C	-40 °C	-40 °C	-	-
	T4 (135 °C)	-40 °C	80 °C	82 °C	80 °C	135 °C	72 °C	135 °C	-40 °C	-40 °C	-40 °C	-	-
	T3 (200 °C)	-40 °C	80 °C	82 °C	80 °C	150 °C	69 °C	150 °C	-40 °C	-40 °C	-40 °C	-	-
2 channels used	T6 ( 85 °C)	-40 °C	54 °C	54 °C	54 °C	85 °C	49 °C	85 °C	-40 °C	-40 °C	-40 °C	-	-
	T5 (100 °C)	-40 °C	69 °C	69 °C	69 °C	100 °C	64 °C	100 °C	-40 °C	-40 °C	-40 °C	-	-
	T4 (135 °C)	-40 °C	78 °C	78 °C	78 °C	135 °C	67 °C	135 °C	-40 °C	-40 °C	-40 °C	-	-
	T3 (200 °C)	-40 °C	78 °C	78 °C	78 °C	150 °C	64 °C	150 °C	-40 °C	-40 °C	-40 °C	-	-

## Antenna and electronics housing: Zone 1

## FMR54

## Position 3 (Power Supply; Output) = C (TRC [04])

Position 5 (Housing) = A													
Power Supply; Output	Temperature class	P 1		P 2		P 3		P 4		P 5		P 6	
		T <sub>p</sub>	T <sub>a</sub>	T <sub>p</sub>	T <sub>a</sub>	T <sub>p</sub>	T <sub>a</sub>	T <sub>p</sub>	T <sub>a</sub>	T <sub>p</sub>	T <sub>a</sub>	T <sub>p</sub>	T <sub>a</sub>
1 channel used	T6 ( 85 °C)	-40 °C	60 °C	60 °C	60 °C	85 °C	48 °C	85 °C	-40 °C	-40 °C	-40 °C	-	-
	T5 (100 °C)	-40 °C	75 °C	75 °C	75 °C	100 °C	63 °C	100 °C	-40 °C	-40 °C	-40 °C	-	-
	T4 (135 °C)	-40 °C	80 °C	81 °C	80 °C	135 °C	61 °C	135 °C	-40 °C	-40 °C	-40 °C	-	-
2 channels used	T6 ( 85 °C)	-40 °C	53 °C	53 °C	53 °C	85 °C	44 °C	85 °C	-40 °C	-40 °C	-40 °C	-	-
	T5 (100 °C)	-40 °C	68 °C	68 °C	68 °C	100 °C	59 °C	100 °C	-40 °C	-40 °C	-40 °C	-	-
	T4 (135 °C)	-40 °C	73 °C	73 °C	73 °C	135 °C	56 °C	135 °C	-40 °C	-40 °C	-40 °C	-	-

Position 5 (Housing) = B													
Power Supply; Output	Temperature class	P 1		P 2		P 3		P 4		P 5		P 6	
		T <sub>p</sub>	T <sub>a</sub>	T <sub>p</sub>	T <sub>a</sub>	T <sub>p</sub>	T <sub>a</sub>	T <sub>p</sub>	T <sub>a</sub>	T <sub>p</sub>	T <sub>a</sub>	T <sub>p</sub>	T <sub>a</sub>
1 channel used	T6 ( 85 °C)	-40 °C	60 °C	60 °C	60 °C	85 °C	53 °C	85 °C	-40 °C	-40 °C	-40 °C	-	-
	T5 (100 °C)	-40 °C	75 °C	75 °C	75 °C	100 °C	68 °C	100 °C	-40 °C	-40 °C	-40 °C	-	-
	T4 (135 °C)	-40 °C	80 °C	82 °C	80 °C	135 °C	69 °C	135 °C	-40 °C	-40 °C	-40 °C	-	-
	T3 (200 °C)	-40 °C	80 °C	82 °C	80 °C	200 °C	52 °C	200 °C	-40 °C	-40 °C	-40 °C	-	-
2 channels used	T6 ( 85 °C)	-40 °C	54 °C	54 °C	54 °C	85 °C	47 °C	85 °C	-40 °C	-40 °C	-40 °C	-	-
	T5 (100 °C)	-40 °C	69 °C	69 °C	69 °C	100 °C	62 °C	100 °C	-40 °C	-40 °C	-40 °C	-	-
	T4 (135 °C)	-40 °C	78 °C	78 °C	78 °C	135 °C	64 °C	135 °C	-40 °C	-40 °C	-40 °C	-	-
	T3 (200 °C)	-40 °C	78 °C	78 °C	78 °C	200 °C	48 °C	200 °C	-40 °C	-40 °C	-40 °C	-	-

Position 5 (Housing) = C													
Power Supply; Output	Temperature class	P 1		P 2		P 3		P 4		P 5		P 6	
		T <sub>p</sub>	T <sub>a</sub>	T <sub>p</sub>	T <sub>a</sub>	T <sub>p</sub>	T <sub>a</sub>	T <sub>p</sub>	T <sub>a</sub>	T <sub>p</sub>	T <sub>a</sub>	T <sub>p</sub>	T <sub>a</sub>
1 channel used	T6 ( 85 °C)	-40 °C	60 °C	60 °C	60 °C	85 °C	54 °C	85 °C	-40 °C	-40 °C	-40 °C	-	-
	T5 (100 °C)	-40 °C	75 °C	75 °C	75 °C	100 °C	69 °C	100 °C	-40 °C	-40 °C	-40 °C	-	-
	T4 (135 °C)	-40 °C	80 °C	82 °C	80 °C	135 °C	71 °C	135 °C	-40 °C	-40 °C	-40 °C	-	-
	T3 (200 °C)	-40 °C	80 °C	82 °C	80 °C	200 °C	58 °C	200 °C	-40 °C	-40 °C	-40 °C	-	-
2 channels used	T6 ( 85 °C)	-40 °C	54 °C	54 °C	54 °C	85 °C	48 °C	85 °C	-40 °C	-40 °C	-40 °C	-	-
	T5 (100 °C)	-40 °C	69 °C	69 °C	69 °C	100 °C	63 °C	100 °C	-40 °C	-40 °C	-40 °C	-	-
	T4 (135 °C)	-40 °C	78 °C	78 °C	78 °C	135 °C	67 °C	135 °C	-40 °C	-40 °C	-40 °C	-	-
	T3 (200 °C)	-40 °C	78 °C	78 °C	78 °C	200 °C	54 °C	200 °C	-40 °C	-40 °C	-40 °C	-	-

**Antenna and electronics housing: Zone 1**

**FMR54**, Position 9, 10 (Seal) = D1

**Position 3 (Power Supply; Output) = C (TRC [04])**

Position 5 (Housing) = A													
Power Supply; Output	Temperature class	P 1		P 2		P 3		P 4		P 5		P 6	
		T <sub>p</sub>	T <sub>a</sub>	T <sub>p</sub>	T <sub>a</sub>	T <sub>p</sub>	T <sub>a</sub>	T <sub>p</sub>	T <sub>a</sub>	T <sub>p</sub>	T <sub>a</sub>	T <sub>p</sub>	T <sub>a</sub>
1 channel used	T6 ( 85 °C)	-196 °C	60 °C	60 °C	60 °C	85 °C	51 °C	85 °C	-40 °C	-40 °C	-40 °C	-196 °C	18 °C
	T5 (100 °C)	-196 °C	75 °C	75 °C	75 °C	100 °C	66 °C	100 °C	-40 °C	-40 °C	-40 °C	-196 °C	18 °C
	T4 (135 °C)	-196 °C	80 °C	81 °C	80 °C	135 °C	66 °C	135 °C	-40 °C	-40 °C	-40 °C	-196 °C	18 °C
	T3 (200 °C)	-196 °C	80 °C	81 °C	80 °C	200 °C	42 °C	200 °C	-40 °C	-40 °C	-40 °C	-196 °C	18 °C
2 channels used	T6 ( 85 °C)	-196 °C	53 °C	53 °C	53 °C	85 °C	46 °C	85 °C	-40 °C	-40 °C	-40 °C	-196 °C	18 °C
	T5 (100 °C)	-196 °C	68 °C	68 °C	68 °C	100 °C	61 °C	100 °C	-40 °C	-40 °C	-40 °C	-196 °C	18 °C
	T4 (135 °C)	-196 °C	73 °C	73 °C	73 °C	135 °C	60 °C	135 °C	-40 °C	-40 °C	-40 °C	-196 °C	18 °C
	T3 (200 °C)	-196 °C	73 °C	73 °C	73 °C	200 °C	42 °C	200 °C	-40 °C	-40 °C	-40 °C	-196 °C	18 °C

Position 5 (Housing) = B													
Power Supply; Output	Temperature class	P 1		P 2		P 3		P 4		P 5		P 6	
		T <sub>p</sub>	T <sub>a</sub>	T <sub>p</sub>	T <sub>a</sub>	T <sub>p</sub>	T <sub>a</sub>	T <sub>p</sub>	T <sub>a</sub>	T <sub>p</sub>	T <sub>a</sub>	T <sub>p</sub>	T <sub>a</sub>
1 channel used	T6 ( 85 °C)	-196 °C	60 °C	60 °C	60 °C	85 °C	55 °C	85 °C	-40 °C	-40 °C	-40 °C	-196 °C	-9 °C
	T5 (100 °C)	-196 °C	75 °C	75 °C	75 °C	100 °C	70 °C	100 °C	-40 °C	-40 °C	-40 °C	-196 °C	-9 °C
	T4 (135 °C)	-196 °C	80 °C	82 °C	80 °C	135 °C	73 °C	135 °C	-40 °C	-40 °C	-40 °C	-196 °C	-9 °C
	T3 (200 °C)	-196 °C	80 °C	82 °C	80 °C	200 °C	62 °C	200 °C	-40 °C	-40 °C	-40 °C	-196 °C	-9 °C
	T2 (300 °C)	-196 °C	80 °C	82 °C	80 °C	280 °C	46 °C	280 °C	-40 °C	-40 °C	-40 °C	-196 °C	-9 °C
2 channels used	T6 ( 85 °C)	-196 °C	54 °C	54 °C	54 °C	85 °C	49 °C	85 °C	-40 °C	-40 °C	-40 °C	-196 °C	-9 °C
	T5 (100 °C)	-196 °C	69 °C	69 °C	69 °C	100 °C	64 °C	100 °C	-40 °C	-40 °C	-40 °C	-196 °C	-9 °C
	T4 (135 °C)	-196 °C	78 °C	78 °C	78 °C	135 °C	68 °C	135 °C	-40 °C	-40 °C	-40 °C	-196 °C	-9 °C
	T3 (200 °C)	-196 °C	78 °C	78 °C	78 °C	200 °C	57 °C	200 °C	-40 °C	-40 °C	-40 °C	-196 °C	-9 °C
	T2 (300 °C)	-196 °C	78 °C	78 °C	78 °C	280 °C	44 °C	280 °C	-40 °C	-40 °C	-40 °C	-196 °C	-9 °C

Position 5 (Housing) = C													
Power Supply; Output	Temperature class	P 1		P 2		P 3		P 4		P 5		P 6	
		T <sub>p</sub>	T <sub>a</sub>	T <sub>p</sub>	T <sub>a</sub>	T <sub>p</sub>	T <sub>a</sub>	T <sub>p</sub>	T <sub>a</sub>	T <sub>p</sub>	T <sub>a</sub>	T <sub>p</sub>	T <sub>a</sub>
1 channel used	T6 ( 85 °C)	-196 °C	60 °C	60 °C	60 °C	85 °C	56 °C	85 °C	-40 °C	-40 °C	-40 °C	-196 °C	-15 °C
	T5 (100 °C)	-196 °C	75 °C	75 °C	75 °C	100 °C	71 °C	100 °C	-40 °C	-40 °C	-40 °C	-196 °C	-15 °C
	T4 (135 °C)	-196 °C	80 °C	82 °C	80 °C	135 °C	74 °C	135 °C	-40 °C	-40 °C	-40 °C	-196 °C	-15 °C
	T3 (200 °C)	-196 °C	80 °C	82 °C	80 °C	200 °C	66 °C	200 °C	-40 °C	-40 °C	-40 °C	-196 °C	-15 °C
	T2 (300 °C)	-196 °C	80 °C	82 °C	80 °C	280 °C	54 °C	280 °C	-40 °C	-40 °C	-40 °C	-196 °C	-15 °C
2 channels used	T6 ( 85 °C)	-196 °C	54 °C	54 °C	54 °C	85 °C	50 °C	85 °C	-40 °C	-40 °C	-40 °C	-196 °C	-15 °C
	T5 (100 °C)	-196 °C	69 °C	69 °C	69 °C	100 °C	65 °C	100 °C	-40 °C	-40 °C	-40 °C	-196 °C	-15 °C
	T4 (135 °C)	-196 °C	78 °C	78 °C	78 °C	135 °C	70 °C	135 °C	-40 °C	-40 °C	-40 °C	-196 °C	-15 °C
	T3 (200 °C)	-196 °C	78 °C	78 °C	78 °C	200 °C	61 °C	200 °C	-40 °C	-40 °C	-40 °C	-196 °C	-15 °C
	T2 (300 °C)	-196 °C	78 °C	78 °C	78 °C	280 °C	51 °C	280 °C	-40 °C	-40 °C	-40 °C	-196 °C	-15 °C

## Antenna and electronics housing: Zone 1

FMR54, Position 9, 10 (Seal) = D2

Position 3 (Power Supply; Output) = C (TRC [04])

Position 5 (Housing) = A													
Power Supply; Output	Temperature class	P 1		P 2		P 3		P 4		P 5		P 6	
		T <sub>p</sub>	T <sub>a</sub>	T <sub>p</sub>	T <sub>a</sub>	T <sub>p</sub>	T <sub>a</sub>	T <sub>p</sub>	T <sub>a</sub>	T <sub>p</sub>	T <sub>a</sub>	T <sub>p</sub>	T <sub>a</sub>
1 channel used	T6 ( 85 °C)	-196 °C	60 °C	60 °C	60 °C	85 °C	52 °C	85 °C	-40 °C	-40 °C	-40 °C	-196 °C	11 °C
	T5 (100 °C)	-196 °C	75 °C	75 °C	75 °C	100 °C	67 °C	100 °C	-40 °C	-40 °C	-40 °C	-196 °C	11 °C
	T4 (135 °C)	-196 °C	80 °C	81 °C	80 °C	135 °C	69 °C	135 °C	-40 °C	-40 °C	-40 °C	-196 °C	11 °C
	T3 (200 °C)	-196 °C	80 °C	81 °C	80 °C	200 °C	47 °C	200 °C	-40 °C	-40 °C	-40 °C	-196 °C	11 °C
2 channels used	T6 ( 85 °C)	-196 °C	53 °C	53 °C	53 °C	85 °C	46 °C	85 °C	-40 °C	-40 °C	-40 °C	-196 °C	11 °C
	T5 (100 °C)	-196 °C	68 °C	68 °C	68 °C	100 °C	61 °C	100 °C	-40 °C	-40 °C	-40 °C	-196 °C	11 °C
	T4 (135 °C)	-196 °C	73 °C	73 °C	73 °C	135 °C	61 °C	135 °C	-40 °C	-40 °C	-40 °C	-196 °C	11 °C
	T3 (200 °C)	-196 °C	73 °C	73 °C	73 °C	200 °C	47 °C	200 °C	-40 °C	-40 °C	-40 °C	-196 °C	11 °C

Position 5 (Housing) = B													
Power Supply; Output	Temperature class	P 1		P 2		P 3		P 4		P 5		P 6	
		T <sub>p</sub>	T <sub>a</sub>	T <sub>p</sub>	T <sub>a</sub>	T <sub>p</sub>	T <sub>a</sub>	T <sub>p</sub>	T <sub>a</sub>	T <sub>p</sub>	T <sub>a</sub>	T <sub>p</sub>	T <sub>a</sub>
1 channel used	T6 ( 85 °C)	-196 °C	60 °C	60 °C	60 °C	85 °C	56 °C	85 °C	-40 °C	-40 °C	-40 °C	-196 °C	-13 °C
	T5 (100 °C)	-196 °C	75 °C	75 °C	75 °C	100 °C	71 °C	100 °C	-40 °C	-40 °C	-40 °C	-196 °C	-13 °C
	T4 (135 °C)	-196 °C	80 °C	82 °C	80 °C	135 °C	74 °C	135 °C	-40 °C	-40 °C	-40 °C	-196 °C	-13 °C
	T3 (200 °C)	-196 °C	80 °C	82 °C	80 °C	200 °C	64 °C	200 °C	-40 °C	-40 °C	-40 °C	-196 °C	-13 °C
	T2 (300 °C)	-196 °C	80 °C	82 °C	80 °C	300 °C	48 °C	300 °C	-40 °C	-40 °C	-40 °C	-196 °C	-13 °C
	T1 (450 °C) *1	-196 °C	80 °C	82 °C	80 °C	400 °C	31 °C	400 °C	-40 °C	-40 °C	-40 °C	-196 °C	-13 °C
2 channels used	T6 ( 85 °C)	-196 °C	54 °C	54 °C	54 °C	85 °C	50 °C	85 °C	-40 °C	-40 °C	-40 °C	-196 °C	-13 °C
	T5 (100 °C)	-196 °C	69 °C	69 °C	69 °C	100 °C	65 °C	100 °C	-40 °C	-40 °C	-40 °C	-196 °C	-13 °C
	T4 (135 °C)	-196 °C	78 °C	78 °C	78 °C	135 °C	70 °C	135 °C	-40 °C	-40 °C	-40 °C	-196 °C	-13 °C
	T3 (200 °C)	-196 °C	78 °C	78 °C	78 °C	200 °C	60 °C	200 °C	-40 °C	-40 °C	-40 °C	-196 °C	-13 °C
	T2 (300 °C)	-196 °C	78 °C	78 °C	78 °C	300 °C	46 °C	300 °C	-40 °C	-40 °C	-40 °C	-196 °C	-13 °C
	T1 (450 °C) *1	-196 °C	78 °C	78 °C	78 °C	400 °C	31 °C	400 °C	-40 °C	-40 °C	-40 °C	-196 °C	-13 °C



Position 5 (Housing) = C													
Power Supply; Output	Temperature class	P 1		P 2		P 3		P 4		P 5		P 6	
		T <sub>p</sub>	T <sub>a</sub>	T <sub>p</sub>	T <sub>a</sub>	T <sub>p</sub>	T <sub>a</sub>	T <sub>p</sub>	T <sub>a</sub>	T <sub>p</sub>	T <sub>a</sub>	T <sub>p</sub>	T <sub>a</sub>
1 channel used	T6 ( 85 °C)	-196 °C	60 °C	60 °C	60 °C	85 °C	57 °C	85 °C	-40 °C	-40 °C	-40 °C	-196 °C	-19 °C
	T5 (100 °C)	-196 °C	75 °C	75 °C	75 °C	100 °C	72 °C	100 °C	-40 °C	-40 °C	-40 °C	-196 °C	-19 °C
	T4 (135 °C)	-196 °C	80 °C	82 °C	80 °C	135 °C	75 °C	135 °C	-40 °C	-40 °C	-40 °C	-196 °C	-19 °C
	T3 (200 °C)	-196 °C	80 °C	82 °C	80 °C	200 °C	68 °C	200 °C	-40 °C	-40 °C	-40 °C	-196 °C	-19 °C
	T2 (300 °C)	-196 °C	80 °C	82 °C	80 °C	300 °C	56 °C	300 °C	-40 °C	-40 °C	-40 °C	-196 °C	-19 °C
	T1 (450 °C) *1	-196 °C	80 °C	82 °C	80 °C	400 °C	42 °C	400 °C	-40 °C	-40 °C	-40 °C	-196 °C	-19 °C
2 channels used	T6 ( 85 °C)	-196 °C	54 °C	54 °C	54 °C	85 °C	51 °C	85 °C	-40 °C	-40 °C	-40 °C	-196 °C	-19 °C
	T5 (100 °C)	-196 °C	69 °C	69 °C	69 °C	100 °C	66 °C	100 °C	-40 °C	-40 °C	-40 °C	-196 °C	-19 °C
	T4 (135 °C)	-196 °C	78 °C	78 °C	78 °C	135 °C	71 °C	135 °C	-40 °C	-40 °C	-40 °C	-196 °C	-19 °C
	T3 (200 °C)	-196 °C	78 °C	78 °C	78 °C	200 °C	64 °C	200 °C	-40 °C	-40 °C	-40 °C	-196 °C	-19 °C
	T2 (300 °C)	-196 °C	78 °C	78 °C	78 °C	300 °C	52 °C	300 °C	-40 °C	-40 °C	-40 °C	-196 °C	-19 °C
	T1 (450 °C) *1	-196 °C	78 °C	78 °C	78 °C	400 °C	41 °C	400 °C	-40 °C	-40 °C	-40 °C	-196 °C	-19 °C

**Antenna and electronics housing: Zone 1**

**FMR54**, Position 7, 8 (Antenna) = Dx

**Position 3 (Power Supply; Output) = C (TRC [04])**

Position 5 (Housing) = A													
Power Supply; Output	Temperature class	P 1		P 2		P 3		P 4		P 5		P 6	
		T <sub>p</sub>	T <sub>a</sub>	T <sub>p</sub>	T <sub>a</sub>	T <sub>p</sub>	T <sub>a</sub>	T <sub>p</sub>	T <sub>a</sub>	T <sub>p</sub>	T <sub>a</sub>	T <sub>p</sub>	T <sub>a</sub>
1 channel used	T6 ( 85 °C)	-40 °C	60 °C	60 °C	60 °C	85 °C	50 °C	85 °C	-40 °C	-40 °C	-40 °C	-	-
	T5 (100 °C)	-40 °C	75 °C	75 °C	75 °C	100 °C	65 °C	100 °C	-40 °C	-40 °C	-40 °C	-	-
	T4 (135 °C)	-40 °C	80 °C	81 °C	80 °C	135 °C	66 °C	135 °C	-40 °C	-40 °C	-40 °C	-	-
	T3 (200 °C)	-40 °C	80 °C	81 °C	80 °C	150 °C	60 °C	150 °C	-40 °C	-40 °C	-40 °C	-	-
2 channels used	T6 ( 85 °C)	-40 °C	53 °C	53 °C	53 °C	85 °C	46 °C	85 °C	-40 °C	-40 °C	-40 °C	-	-
	T5 (100 °C)	-40 °C	68 °C	68 °C	68 °C	100 °C	61 °C	100 °C	-40 °C	-40 °C	-40 °C	-	-
	T4 (135 °C)	-40 °C	73 °C	73 °C	73 °C	135 °C	59 °C	135 °C	-40 °C	-40 °C	-40 °C	-	-
	T3 (200 °C)	-40 °C	73 °C	73 °C	73 °C	150 °C	56 °C	150 °C	-40 °C	-40 °C	-40 °C	-	-

Position 5 (Housing) = B													
Power Supply; Output	Temperature class	P 1		P 2		P 3		P 4		P 5		P 6	
		T <sub>p</sub>	T <sub>a</sub>	T <sub>p</sub>	T <sub>a</sub>	T <sub>p</sub>	T <sub>a</sub>	T <sub>p</sub>	T <sub>a</sub>	T <sub>p</sub>	T <sub>a</sub>	T <sub>p</sub>	T <sub>a</sub>
1 channel used	T6 ( 85 °C)	-40 °C	60 °C	60 °C	60 °C	85 °C	55 °C	85 °C	-40 °C	-40 °C	-40 °C	-	-
	T5 (100 °C)	-40 °C	75 °C	75 °C	75 °C	100 °C	70 °C	100 °C	-40 °C	-40 °C	-40 °C	-	-
	T4 (135 °C)	-40 °C	80 °C	82 °C	80 °C	135 °C	72 °C	135 °C	-40 °C	-40 °C	-40 °C	-	-
	T3 (200 °C)	-40 °C	80 °C	82 °C	80 °C	150 °C	70 °C	150 °C	-40 °C	-40 °C	-40 °C	-	-
2 channels used	T6 ( 85 °C)	-40 °C	54 °C	54 °C	54 °C	85 °C	49 °C	85 °C	-40 °C	-40 °C	-40 °C	-	-
	T5 (100 °C)	-40 °C	69 °C	69 °C	69 °C	100 °C	64 °C	100 °C	-40 °C	-40 °C	-40 °C	-	-
	T4 (135 °C)	-40 °C	78 °C	78 °C	78 °C	135 °C	68 °C	135 °C	-40 °C	-40 °C	-40 °C	-	-
	T3 (200 °C)	-40 °C	78 °C	78 °C	78 °C	150 °C	65 °C	150 °C	-40 °C	-40 °C	-40 °C	-	-

Position 5 (Housing) = C													
Power Supply; Output	Temperature class	P 1		P 2		P 3		P 4		P 5		P 6	
		T <sub>p</sub>	T <sub>a</sub>	T <sub>p</sub>	T <sub>a</sub>	T <sub>p</sub>	T <sub>a</sub>	T <sub>p</sub>	T <sub>a</sub>	T <sub>p</sub>	T <sub>a</sub>	T <sub>p</sub>	T <sub>a</sub>
1 channel used	T6 ( 85 °C)	-40 °C	60 °C	60 °C	60 °C	85 °C	56 °C	85 °C	-40 °C	-40 °C	-40 °C	-	-
	T5 (100 °C)	-40 °C	75 °C	75 °C	75 °C	100 °C	71 °C	100 °C	-40 °C	-40 °C	-40 °C	-	-
	T4 (135 °C)	-40 °C	80 °C	82 °C	80 °C	135 °C	74 °C	135 °C	-40 °C	-40 °C	-40 °C	-	-
	T3 (200 °C)	-40 °C	80 °C	82 °C	80 °C	150 °C	72 °C	150 °C	-40 °C	-40 °C	-40 °C	-	-
2 channels used	T6 ( 85 °C)	-40 °C	54 °C	54 °C	54 °C	85 °C	50 °C	85 °C	-40 °C	-40 °C	-40 °C	-	-
	T5 (100 °C)	-40 °C	69 °C	69 °C	69 °C	100 °C	65 °C	100 °C	-40 °C	-40 °C	-40 °C	-	-
	T4 (135 °C)	-40 °C	78 °C	78 °C	78 °C	135 °C	70 °C	135 °C	-40 °C	-40 °C	-40 °C	-	-
	T3 (200 °C)	-40 °C	78 °C	78 °C	78 °C	150 °C	68 °C	150 °C	-40 °C	-40 °C	-40 °C	-	-

### Antenna and electronics housing: Zone 1

FMR56, Position 7, 8 (Antenna) = BN, BR

Position 3 (Power Supply; Output) = C (TRC [04])

Position 5 (Housing) = A													
Power Supply; Output	Temperature class	P 1		P 2		P 3		P 4		P 5		P 6	
		T <sub>p</sub>	T <sub>a</sub>	T <sub>p</sub>	T <sub>a</sub>	T <sub>p</sub>	T <sub>a</sub>	T <sub>p</sub>	T <sub>a</sub>	T <sub>p</sub>	T <sub>a</sub>	T <sub>p</sub>	T <sub>a</sub>
1 channel used	T6 ( 85 °C)	-40 °C	60 °C	60 °C	60 °C	80 °C	55 °C	80 °C	-40 °C	-40 °C	-40 °C	-	-
2 channels used	T6 ( 85 °C)	-40 °C	53 °C	53 °C	53 °C	80 °C	48 °C	80 °C	-40 °C	-40 °C	-40 °C	-	-

Position 5 (Housing) = C													
Power Supply; Output	Temperature class	P 1		P 2		P 3		P 4		P 5		P 6	
		T <sub>p</sub>	T <sub>a</sub>	T <sub>p</sub>	T <sub>a</sub>	T <sub>p</sub>	T <sub>a</sub>	T <sub>p</sub>	T <sub>a</sub>	T <sub>p</sub>	T <sub>a</sub>	T <sub>p</sub>	T <sub>a</sub>
1 channel used	T6 ( 85 °C)	-40 °C	60 °C	60 °C	60 °C	80 °C	58 °C	80 °C	-40 °C	-40 °C	-40 °C	-	-
2 channels used	T6 ( 85 °C)	-40 °C	54 °C	54 °C	54 °C	80 °C	52 °C	80 °C	-40 °C	-40 °C	-40 °C	-	-

Antenna and electronics housing: Zone 1

FMR57

Position 3 (Power Supply; Output) = C (TRC [04])

Position 5 (Housing) = A													
Power Supply; Output	Temperature class	P 1		P 2		P 3		P 4		P 5		P 6	
		T <sub>p</sub>	T <sub>a</sub>	T <sub>p</sub>	T <sub>a</sub>	T <sub>p</sub>	T <sub>a</sub>	T <sub>p</sub>	T <sub>a</sub>	T <sub>p</sub>	T <sub>a</sub>	T <sub>p</sub>	T <sub>a</sub>
1 channel used	T6 ( 85 °C)	-40 °C	60 °C	60 °C	60 °C	85 °C	53 °C	85 °C	-40 °C	-40 °C	-40 °C	-	-
	T5 (100 °C)	-40 °C	75 °C	75 °C	75 °C	100 °C	68 °C	100 °C	-40 °C	-40 °C	-40 °C	-	-
	T4 (135 °C)	-40 °C	80 °C	81 °C	80 °C	135 °C	71 °C	135 °C	-40 °C	-40 °C	-40 °C	-	-
	T3 (200 °C)	-40 °C	80 °C	81 °C	80 °C	200 °C	53 °C	200 °C	-40 °C	-40 °C	-40 °C	-	-
2 channels used	T6 ( 85 °C)	-40 °C	53 °C	53 °C	53 °C	85 °C	47 °C	85 °C	-40 °C	-40 °C	-40 °C	-	-
	T5 (100 °C)	-40 °C	68 °C	68 °C	68 °C	100 °C	62 °C	100 °C	-40 °C	-40 °C	-40 °C	-	-
	T4 (135 °C)	-40 °C	73 °C	73 °C	73 °C	135 °C	63 °C	135 °C	-40 °C	-40 °C	-40 °C	-	-
	T3 (200 °C)	-40 °C	73 °C	73 °C	73 °C	200 °C	52 °C	200 °C	-40 °C	-40 °C	-40 °C	-	-

Position 5 (Housing) = B													
Power Supply; Output	Temperature class	P 1		P 2		P 3		P 4		P 5		P 6	
		T <sub>p</sub>	T <sub>a</sub>	T <sub>p</sub>	T <sub>a</sub>	T <sub>p</sub>	T <sub>a</sub>	T <sub>p</sub>	T <sub>a</sub>	T <sub>p</sub>	T <sub>a</sub>	T <sub>p</sub>	T <sub>a</sub>
1 channel used	T6 ( 85 °C)	-40 °C	60 °C	60 °C	60 °C	85 °C	56 °C	85 °C	-40 °C	-40 °C	-40 °C	-	-
	T5 (100 °C)	-40 °C	75 °C	75 °C	75 °C	100 °C	71 °C	100 °C	-40 °C	-40 °C	-40 °C	-	-
	T4 (135 °C)	-40 °C	80 °C	82 °C	80 °C	135 °C	75 °C	135 °C	-40 °C	-40 °C	-40 °C	-	-
	T3 (200 °C)	-40 °C	80 °C	82 °C	80 °C	200 °C	67 °C	200 °C	-40 °C	-40 °C	-40 °C	-	-
2 channels used	T6 ( 85 °C)	-40 °C	54 °C	54 °C	54 °C	85 °C	51 °C	85 °C	-40 °C	-40 °C	-40 °C	-	-
	T5 (100 °C)	-40 °C	69 °C	69 °C	69 °C	100 °C	66 °C	100 °C	-40 °C	-40 °C	-40 °C	-	-
	T4 (135 °C)	-40 °C	78 °C	78 °C	78 °C	135 °C	71 °C	135 °C	-40 °C	-40 °C	-40 °C	-	-
	T3 (200 °C)	-40 °C	78 °C	78 °C	78 °C	200 °C	63 °C	200 °C	-40 °C	-40 °C	-40 °C	-	-

Position 5 (Housing) = C													
Power Supply; Output	Temperature class	P 1		P 2		P 3		P 4		P 5		P 6	
		T <sub>p</sub>	T <sub>a</sub>	T <sub>p</sub>	T <sub>a</sub>	T <sub>p</sub>	T <sub>a</sub>	T <sub>p</sub>	T <sub>a</sub>	T <sub>p</sub>	T <sub>a</sub>	T <sub>p</sub>	T <sub>a</sub>
1 channel used	T6 ( 85 °C)	-40 °C	60 °C	60 °C	60 °C	85 °C	57 °C	85 °C	-40 °C	-40 °C	-40 °C	-	-
	T5 (100 °C)	-40 °C	75 °C	75 °C	75 °C	100 °C	72 °C	100 °C	-40 °C	-40 °C	-40 °C	-	-
	T4 (135 °C)	-40 °C	80 °C	82 °C	80 °C	135 °C	77 °C	135 °C	-40 °C	-40 °C	-40 °C	-	-
	T3 (200 °C)	-40 °C	80 °C	82 °C	80 °C	200 °C	70 °C	200 °C	-40 °C	-40 °C	-40 °C	-	-
2 channels used	T6 ( 85 °C)	-40 °C	54 °C	54 °C	54 °C	85 °C	51 °C	85 °C	-40 °C	-40 °C	-40 °C	-	-
	T5 (100 °C)	-40 °C	69 °C	69 °C	69 °C	100 °C	66 °C	100 °C	-40 °C	-40 °C	-40 °C	-	-
	T4 (135 °C)	-40 °C	78 °C	78 °C	78 °C	135 °C	73 °C	135 °C	-40 °C	-40 °C	-40 °C	-	-
	T3 (200 °C)	-40 °C	78 °C	78 °C	78 °C	200 °C	66 °C	200 °C	-40 °C	-40 °C	-40 °C	-	-

## Antenna and electronics housing: Zone 1

FMR57, Position 9, 10 (Seal) = D4

Position 3 (Power Supply; Output) = C (TRC [04])

Position 5 (Housing) = A													
Power Supply; Output	Temperature class	P 1		P 2		P 3		P 4		P 5		P 6	
		T <sub>p</sub>	T <sub>a</sub>	T <sub>p</sub>	T <sub>a</sub>	T <sub>p</sub>	T <sub>a</sub>	T <sub>p</sub>	T <sub>a</sub>	T <sub>p</sub>	T <sub>a</sub>	T <sub>p</sub>	T <sub>a</sub>
1 channel used	T6 ( 85 °C)	-40 °C	60 °C	60 °C	60 °C	85 °C	54 °C	85 °C	-40 °C	-40 °C	-40 °C	-	-
	T5 (100 °C)	-40 °C	75 °C	75 °C	75 °C	100 °C	69 °C	100 °C	-40 °C	-40 °C	-40 °C	-	-
	T4 (135 °C)	-40 °C	80 °C	81 °C	80 °C	135 °C	74 °C	135 °C	-40 °C	-40 °C	-40 °C	-	-
	T3 (200 °C)	-40 °C	80 °C	81 °C	80 °C	200 °C	59 °C	200 °C	-40 °C	-40 °C	-40 °C	-	-
	T2 (300 °C)	-40 °C	80 °C	81 °C	80 °C	300 °C	37 °C	300 °C	-40 °C	-40 °C	-40 °C	-	-
2 channels used	T6 ( 85 °C)	-40 °C	53 °C	53 °C	53 °C	85 °C	48 °C	85 °C	-40 °C	-40 °C	-40 °C	-	-
	T5 (100 °C)	-40 °C	68 °C	68 °C	68 °C	100 °C	63 °C	100 °C	-40 °C	-40 °C	-40 °C	-	-
	T4 (135 °C)	-40 °C	73 °C	73 °C	73 °C	135 °C	65 °C	135 °C	-40 °C	-40 °C	-40 °C	-	-
	T3 (200 °C)	-40 °C	73 °C	73 °C	73 °C	200 °C	56 °C	200 °C	-40 °C	-40 °C	-40 °C	-	-
	T2 (300 °C)	-40 °C	73 °C	73 °C	73 °C	300 °C	37 °C	300 °C	-40 °C	-40 °C	-40 °C	-	-

Position 5 (Housing) = B													
Power Supply; Output	Temperature class	P 1		P 2		P 3		P 4		P 5		P 6	
		T <sub>p</sub>	T <sub>a</sub>	T <sub>p</sub>	T <sub>a</sub>	T <sub>p</sub>	T <sub>a</sub>	T <sub>p</sub>	T <sub>a</sub>	T <sub>p</sub>	T <sub>a</sub>	T <sub>p</sub>	T <sub>a</sub>
1 channel used	T6 ( 85 °C)	-40 °C	60 °C	60 °C	60 °C	85 °C	57 °C	85 °C	-40 °C	-40 °C	-40 °C	-	-
	T5 (100 °C)	-40 °C	75 °C	75 °C	75 °C	100 °C	72 °C	100 °C	-40 °C	-40 °C	-40 °C	-	-
	T4 (135 °C)	-40 °C	80 °C	82 °C	80 °C	135 °C	77 °C	135 °C	-40 °C	-40 °C	-40 °C	-	-
	T3 (200 °C)	-40 °C	80 °C	82 °C	80 °C	200 °C	71 °C	200 °C	-40 °C	-40 °C	-40 °C	-	-
	T2 (300 °C)	-40 °C	80 °C	82 °C	80 °C	300 °C	62 °C	300 °C	-40 °C	-40 °C	-40 °C	-	-
	T1 (450 °C) *1	-40 °C	80 °C	82 °C	80 °C	400 °C	51 °C	400 °C	-40 °C	-40 °C	-40 °C	-	-
2 channels used	T6 ( 85 °C)	-40 °C	54 °C	54 °C	54 °C	85 °C	52 °C	85 °C	-40 °C	-40 °C	-40 °C	-	-
	T5 (100 °C)	-40 °C	69 °C	69 °C	69 °C	100 °C	67 °C	100 °C	-40 °C	-40 °C	-40 °C	-	-
	T4 (135 °C)	-40 °C	78 °C	78 °C	78 °C	135 °C	73 °C	135 °C	-40 °C	-40 °C	-40 °C	-	-
	T3 (200 °C)	-40 °C	78 °C	78 °C	78 °C	200 °C	67 °C	200 °C	-40 °C	-40 °C	-40 °C	-	-
	T2 (300 °C)	-40 °C	78 °C	78 °C	78 °C	300 °C	58 °C	300 °C	-40 °C	-40 °C	-40 °C	-	-
	T1 (450 °C) *1	-40 °C	78 °C	78 °C	78 °C	400 °C	49 °C	400 °C	-40 °C	-40 °C	-40 °C	-	-

Position 5 (Housing) = C													
Power Supply; Output	Temperature class	P 1		P 2		P 3		P 4		P 5		P 6	
		T <sub>p</sub>	T <sub>a</sub>	T <sub>p</sub>	T <sub>a</sub>	T <sub>p</sub>	T <sub>a</sub>	T <sub>p</sub>	T <sub>a</sub>	T <sub>p</sub>	T <sub>a</sub>	T <sub>p</sub>	T <sub>a</sub>
1 channel used	T6 ( 85 °C)	-40 °C	60 °C	60 °C	60 °C	85 °C	58 °C	85 °C	-40 °C	-40 °C	-40 °C	-	-
	T5 (100 °C)	-40 °C	75 °C	75 °C	75 °C	100 °C	73 °C	100 °C	-40 °C	-40 °C	-40 °C	-	-
	T4 (135 °C)	-40 °C	80 °C	82 °C	80 °C	135 °C	78 °C	135 °C	-40 °C	-40 °C	-40 °C	-	-
	T3 (200 °C)	-40 °C	80 °C	82 °C	80 °C	200 °C	73 °C	200 °C	-40 °C	-40 °C	-40 °C	-	-
	T2 (300 °C)	-40 °C	80 °C	82 °C	80 °C	300 °C	66 °C	300 °C	-40 °C	-40 °C	-40 °C	-	-
	T1 (450 °C) * <sup>1</sup>	-40 °C	80 °C	82 °C	80 °C	400 °C	59 °C	400 °C	-40 °C	-40 °C	-40 °C	-	-
2 channels used	T6 ( 85 °C)	-40 °C	54 °C	54 °C	54 °C	85 °C	52 °C	85 °C	-40 °C	-40 °C	-40 °C	-	-
	T5 (100 °C)	-40 °C	69 °C	69 °C	69 °C	100 °C	67 °C	100 °C	-40 °C	-40 °C	-40 °C	-	-
	T4 (135 °C)	-40 °C	78 °C	78 °C	78 °C	135 °C	74 °C	135 °C	-40 °C	-40 °C	-40 °C	-	-
	T3 (200 °C)	-40 °C	78 °C	78 °C	78 °C	200 °C	69 °C	200 °C	-40 °C	-40 °C	-40 °C	-	-
	T2 (300 °C)	-40 °C	78 °C	78 °C	78 °C	300 °C	62 °C	300 °C	-40 °C	-40 °C	-40 °C	-	-
	T1 (450 °C) * <sup>1</sup>	-40 °C	78 °C	78 °C	78 °C	400 °C	55 °C	400 °C	-40 °C	-40 °C	-40 °C	-	-

## Antenna and electronics housing: Zone 0

## FMR5x

## Position 3 (Power Supply; Output) = C (TRC [04])

Position 5 (Housing) = A													
Power Supply; Output	Temperature class	P 1		P 2		P 3		P 4		P 5		P 6	
		T <sub>p</sub>	T <sub>a</sub>	T <sub>p</sub>	T <sub>a</sub>	T <sub>p</sub>	T <sub>a</sub>	T <sub>p</sub>	T <sub>a</sub>	T <sub>p</sub>	T <sub>a</sub>	T <sub>p</sub>	T <sub>a</sub>
1 channel used	T6 ( 85 °C)	-20 °C	48 °C	48 °C	48 °C	48 °C	42 °C	48 °C	-20 °C	-20 °C	-20 °C	-	-
	T5 (100 °C)	-20 °C	60 °C	60 °C	60 °C	60 °C	60 °C	60 °C	-20 °C	-20 °C	-20 °C	-	-
2 channels used	T6 ( 85 °C)	-20 °C	41 °C	41 °C	41 °C	41 °C	36 °C	41 °C	-20 °C	-20 °C	-20 °C	-	-
	T5 (100 °C)	-20 °C	53 °C	53 °C	53 °C	53 °C	51 °C	53 °C	-20 °C	-20 °C	-20 °C	-	-
	T4 (135 °C)	-20 °C	60 °C	60 °C	60 °C	60 °C	60 °C	60 °C	-20 °C	-20 °C	-20 °C	-	-

Position 5 (Housing) = B													
Power Supply; Output	Temperature class	P 1		P 2		P 3		P 4		P 5		P 6	
		T <sub>p</sub>	T <sub>a</sub>	T <sub>p</sub>	T <sub>a</sub>	T <sub>p</sub>	T <sub>a</sub>	T <sub>p</sub>	T <sub>a</sub>	T <sub>p</sub>	T <sub>a</sub>	T <sub>p</sub>	T <sub>a</sub>
1 channel used	T6 ( 85 °C)	-20 °C	48 °C	48 °C	48 °C	48 °C	44 °C	48 °C	-20 °C	-20 °C	-20 °C	-	-
	T5 (100 °C)	-20 °C	60 °C	60 °C	60 °C	60 °C	60 °C	60 °C	-20 °C	-20 °C	-20 °C	-	-
2 channels used	T6 ( 85 °C)	-20 °C	42 °C	42 °C	42 °C	42 °C	38 °C	42 °C	-20 °C	-20 °C	-20 °C	-	-
	T5 (100 °C)	-20 °C	54 °C	54 °C	54 °C	54 °C	53 °C	54 °C	-20 °C	-20 °C	-20 °C	-	-
	T4 (135 °C)	-20 °C	60 °C	60 °C	60 °C	60 °C	60 °C	60 °C	-20 °C	-20 °C	-20 °C	-	-

Position 5 (Housing) = C													
Power Supply; Output	Temperature class	P 1		P 2		P 3		P 4		P 5		P 6	
		T <sub>p</sub>	T <sub>a</sub>	T <sub>p</sub>	T <sub>a</sub>	T <sub>p</sub>	T <sub>a</sub>	T <sub>p</sub>	T <sub>a</sub>	T <sub>p</sub>	T <sub>a</sub>	T <sub>p</sub>	T <sub>a</sub>
1 channel used	T6 ( 85 °C)	-20 °C	48 °C	48 °C	48 °C	48 °C	45 °C	48 °C	-20 °C	-20 °C	-20 °C	-	-
	T5 (100 °C)	-20 °C	60 °C	60 °C	60 °C	60 °C	60 °C	60 °C	-20 °C	-20 °C	-20 °C	-	-
2 channels used	T6 ( 85 °C)	-20 °C	42 °C	42 °C	42 °C	42 °C	39 °C	42 °C	-20 °C	-20 °C	-20 °C	-	-
	T5 (100 °C)	-20 °C	54 °C	54 °C	54 °C	54 °C	53 °C	54 °C	-20 °C	-20 °C	-20 °C	-	-
	T4 (135 °C)	-20 °C	60 °C	60 °C	60 °C	60 °C	60 °C	60 °C	-20 °C	-20 °C	-20 °C	-	-





71252400

[www.addresses.endress.com](http://www.addresses.endress.com)

---