

Safety Instruction

Proservo NMS 53x Series (NMS5)

Intelligent Tank Gauge

KEMA 05 ATEX 2071



Safety Instructions for Electrical Apparatus Certified for Use in Explosion-hazardous Areas

Designation according to Directive 94/9/EC
NMS531/532/534/535/536

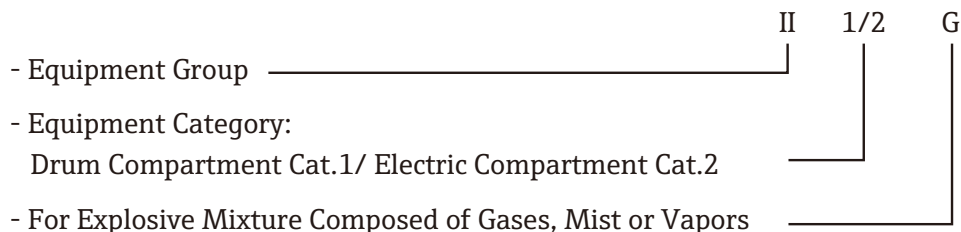

Equipment Protection Level (EPL): Ga/Gb
NMS531/532/534/535/536

- Drum Compartment Zone 0
- Electric Compartment Zone 1

Hazardous Zone at Mounting Point		Category to Directive 94/9/EC	Ignition Protection Provided		
			Ga	Gb	Gc
Hazard due to explosive gas-air mixture	Zone 0	1G	○	×	×
Hazard due to explosive gas-air mixture	Zone 1	2G	○	○	×
Hazard due to explosive gas-air mixture	Zone 2	3G	○	○	○

○ : Applicable × : Not Applicable



Table of Contents

1	Safety Notes for Installation in Hazardous Areas ..	4	4	Supply, Interface Circuit and Intrinsically	
				Safety Signal Circuit	7
2	Cables and Wiring	4	4.1	Ex d Version	7
2.1	Cable Entry	4	4.2	Ex d [ia] Version	7
2.2	Cable Connection	4			
2.3	Conduit Connection	4	5	Ambient Temperature	8
2.4	Wiring of Intrinsically Safety Circuit	4	6	Applied Standards.....	9
2.5	Thread Form of Cable Entries	5	7	Declaration of Conformity	10
2.6	Unused Cable Entries	5			
2.7	External Gland	5			
2.8	Disassembly and Repairs	6			
3	Applicable Maximum Installation Height	6			

Proservo NMS531/532/534/536/537

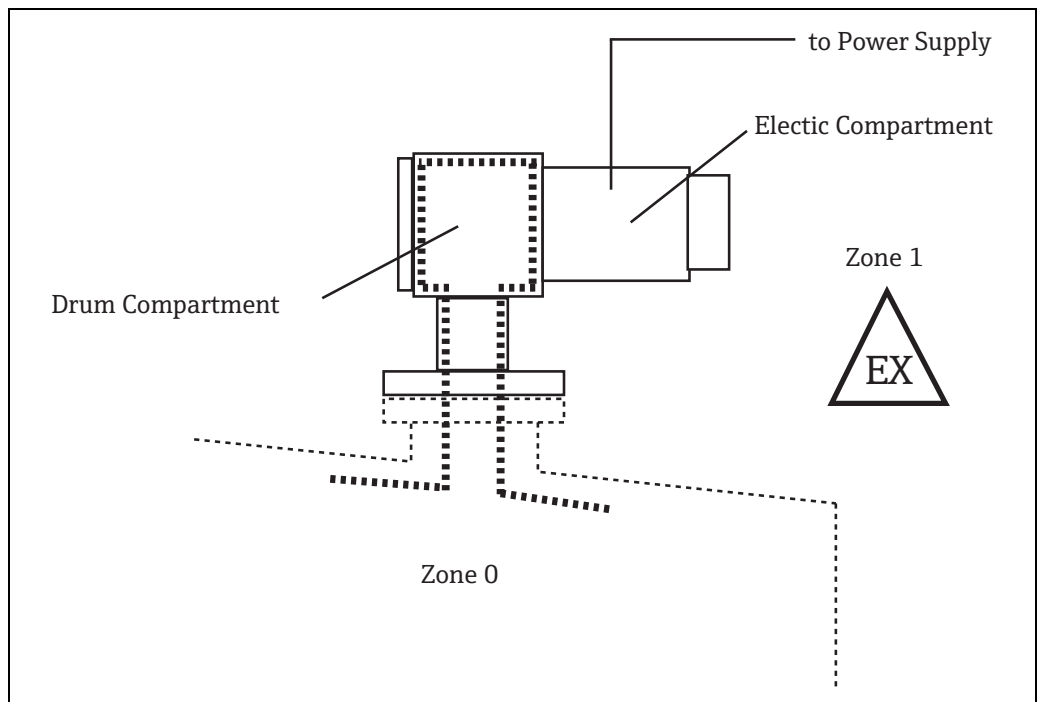

Figure 1: Proservo NMS5 Layout

NMS5 External Connection

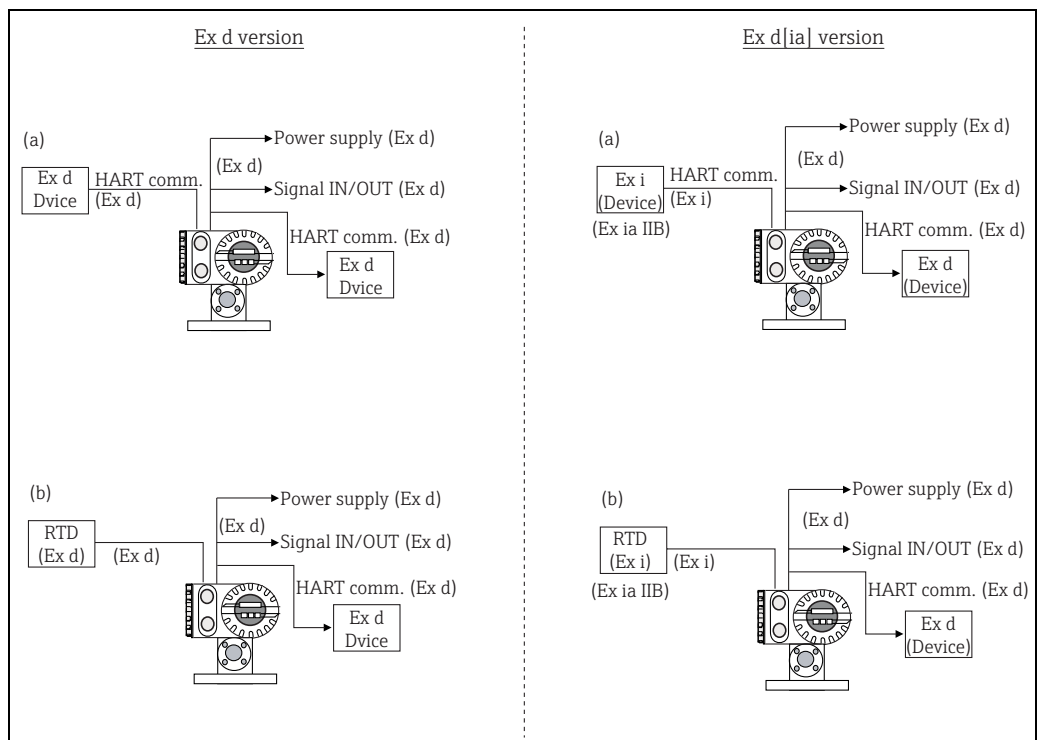

Figure 2: External Connection

1 Safety Notes for Installation in Hazardous Areas

- Install NMS53x according to the manufacturer's instructions and any other valid standards and guidelines.
- Do not open the connection compartment cover and/or electric compartment cover under voltage in explosive atmospheres. Do not open the cover when an explosive atmosphere is present.
- Installation of tank gauge NMS53x is to be made so, that no waving or rolling motion of the displacer can occur in operation causing a contact of the displacer with the tank wall. In case of the drum housing made of aluminum (NMS5-1... and NMS5-4...), no impact or friction to the equipment to avoid ignition hazard between the drum housing and internal parts.

2 Cables and Wiring

2.1 Cable Entry

- Only certified cable entries must be used for the intended cables. Selection criteria as per IEC 60079-14 must be observed.

 **WARNING**

The cable glands must be applied to Section "10.4.2 d) or e) in IEC60079-14" for Proservo NMS53x.

- For operating the tank gauge housing at an ambient temperature under -20°C, appropriate cables and cable entries permitted for this application must be used.

2.2 Cable Connection

The cable entry device shall be certified in type of protection flameproof enclosure "d", suitable for the conditions of use and correctly installed.

The cable and cable glands shall be suitable for at least 80°C.

2.3 Conduit Connection

A certified sealing device in type of protection flameproof enclosure "d", such as a conduit seal with setting compound shall be provided immediately to the entrance of the enclosure. The wiring and setting compound in the conduit seal shall be suitable for at least 80°C.

Blanking elements of unused apertures shall be certified in type of protection flameproof enclosure "d", suitable for the conditions of use and correctly installed.

2.4 Wiring of Intrinsically Safety Circuit

If the product is provided with the optionally intrinsically safe circuit, the connection shall be made via separate cable gland and with a cable type permitted for that purpose.

2.5 Thread From of Cable Entries

If mating conduits are not matched, reducing rings are to be used. Following table shows availability for reducing rings;

Thread of Enclosure	Thread Type of Conduit								
	G1"	G3/4"	G1/2"	NPT1/2"	NPT3/4"	PG16	PG21	M20	M25
G1"	-----	○	○	○	○	○	○	○	○
G3/4"	-----	-----	○	○	○	○	○	○	○

○ : applicable, ----- : not applicable

G1" thread of conduit is screwed to the enclosure directly, G3/4" thread of conduit is screwed to the enclosure directly or use reducing ring (G1 to G3/4).

Thread Type	G	NPT	PG	M
Tolerance	Class B	Between 0 and +2 past the nominal mark (ANSI/ASME B1.20.1)	According to DIN 40430	Male: 6g Female: 6H

CAUTION

The cable entries show "h" or "g" in order code of NMS5 -abcdefghijkmlm and NMS7-abcdefghijllm.

NMS5-....h.....		NMS7-....g.....	
E	Cable entry: Four G(PF) 1/2" thread	A	Cable entry: Four G(PF) 1/2" thread
F	Cable entry: Four G(PF) 3/4" thread	B	Cable entry: Four G(PF) 3/4" thread
G	Cable entry: Four NPT 1/2" thread	C	Cable entry: Four NPT 1/2" thread
H	Cable entry: Four NPT 3/4" thread	D	Cable entry: Four NPT 3/4" thread
J	Cable entry: Four PG16 thread	E	Cable entry: Four PG16 thread
K	Cable entry: Four PG21 thread	F	Cable entry: Four PG21 thread
L	Cable entry: Four M20 thread	G	Cable entry: Four M20 thread
M	Cable entry: Four M25 thread	H	Cable entry: Four M25 thread
Y	Special version	Y	Special version

2.6 Unused Cable Entries

All of unused cable entries of the enclosure (G 1 or G 3/4) are to be plugged directly by stopping plug. No reducing rings are allowed to be used for stopping. The purchased stopping plug shall be IECEx certified Ex d stopping plugs, with an operating temperature range at least 40°C to +66°C. Reducing rings, stopping plugs and cable entries become secured e.g. with stopping pin, with set screw or with Loctite cement against rotating.

2.7 External Gland

For connection of an external earthing or bonding conductor a cable lug shall be used. The conductor shall be mounted so that it is secured against loosening and twisting.

2.8 Disassembly and Repairs

Disassembly and/or repair of electronic compartment and drum compartment (cylindrical joint part) are strictly prohibited.

The property class of M6 x 28 fasteners used for the flameproof enclosure is 12.9.

Thread Size of Covers

	Thread Size	Pitch	Tolerance of Fit	Engagement
Terminal box cover	M130	2	6H/6g	>=5.4 threads
Display cover	M120	2	6H/6g	>=5 threads

3 Applicable Maximum Installation Height

Avoid ignition hazard between the displacer and tank bottom when the displacer wire breaks and displacer drops down to tank bottom. Applicable maximum tank height (Hmax) is depending on displacer weight (Wd) as follows;

Displacer Weight	252g (Standard)	270g (Standard; Maximum)	300g (Weight & Measure)
IIB version	50.5m	47.1m	42.4m
IIC version	24.2m	22.6m	20.3m

EN 13463-1:2009 clause 6.3.2.2.1 requirement of single impact energy limits:

- E <= 60 J (Zone 0, IIC)
- E <= 125 J (Zone 0, IIB)

Calculate Function: $H_{max} = E / (W_d * 9.81)$

CAUTION

In case of tank gauge installation over the maximum height, when the tank is empty and explosive gas/vapor is present, displacer should be down to tank bottom to avoid ignition hazard between the displacer and the tank bottom.

4 Supply, Interface Circuit and Intrinsically Safety Signal Circuit

4.1 Ex d Version

Power Supply: [Terminals: 1(L+), 2(N-), 3(GND)]

High Voltage Type	Low Voltage Type
NMS5-.G.....3...., NMS5-.Q.....3.... or NMS5-.S.....3....	NMS5-.G.....4...., NMS5-.Q.....4.... or NMS5-.S.....4....
U=85V...264V AC, 50/60 Hz, max. 50 VA	U=19V ... 55V AC, 50/60 Hz, max. 50 VA U=19V ... 62 V DC, max. 50W

Interface Circuit

Interface Circuit	[Terminals:4-23]	U=24V, max.50 mA
External Device Connection	[Terminals: 24(+), 25(-), 26(N.C.)]	U=28.7 V
External RTD Connection	[Terminals: 24(A), 25(B), 26(b)]	U=11.3 V

4.2 Ex d [ia] Version

Power Supply: [Terminals: 1(L+), 2(N-), 3(GND)]

High Voltage Type	Low Voltage Type
NMS5-.J.....3.... or NMS5-.U.....3....	NMS5-...J.....4.... or NMS5-.U.....4....
85V...253V AC, 50/60 Hz, max. 50 VA Um = 253 V	19V ... 55V AC, 50/60 Hz, max. 50 VA 19V ... 62 V DC, max. 50W Um = 253 V

Interface Circuit: [Terminal: 4-23]

U=24V, max.50 mA Um=253 V

External Intrinsic Safety Device Connection: [Terminals: 24(+), 25(-), 26(N.C.)]

Only for connection to a certified intrinsically safe device with the following maximum value

U _o = 28.7 V I _o = 114 mA P _o = 816 mW	External Capacitance External Inductance	Co = 615 nF Lo = 10 mH
---	---	---------------------------

External RTD Connection: [Terminals: 24(A), 25(B), 26(b)]

Only for connection to a certified intrinsic safety RTD (EEx ia IIB) or simple apparatus with the following maximum value

U _o = 11.3 V I _o = 81.6 mA P _o = 406 mW	Internal Resistance External Capacitance External Inductance	R _i min = 406 ohm Co = 1.3 µF Lo = 4.0 mH
--	--	--

5 Ambient Temperature

Ambient Temperature Range

- -20°C to +60°C (Standard (IIB) Version, IIC Version)
- -40°C to +60°C (Low Temperature Version for Cold Area; Only IIB Version)
- Process Temperature Range: -200°C to +200°C

Temperature class of the equipment is depending on process (liquid) temperature as follows;

Temperature Class	Ambient Temperature	Process Temperature (Temperature of Displacer)
T6	-20°C (or -40°C) $\leq T_a \leq 60^{\circ}\text{C}$	$\leq 85^{\circ}\text{C}$
T5		$\leq 100^{\circ}\text{C}$
T4		$\leq 135^{\circ}\text{C}$
T3		$\leq 200^{\circ}\text{C}$

CAUTION

The process temperature shall not bring the enclosure of the electronics compartment besides the ambient temperature range.

When installing NMS5 to high or low temperature storage tank, heat or cold from the liquid or tank wall should not be emitted to NMS5 directly.

Cover the tank with a thermal isolation material and/or install an ambient temperature adjust pipe between NMS5 and nozzle of the tank (see Figure 3).

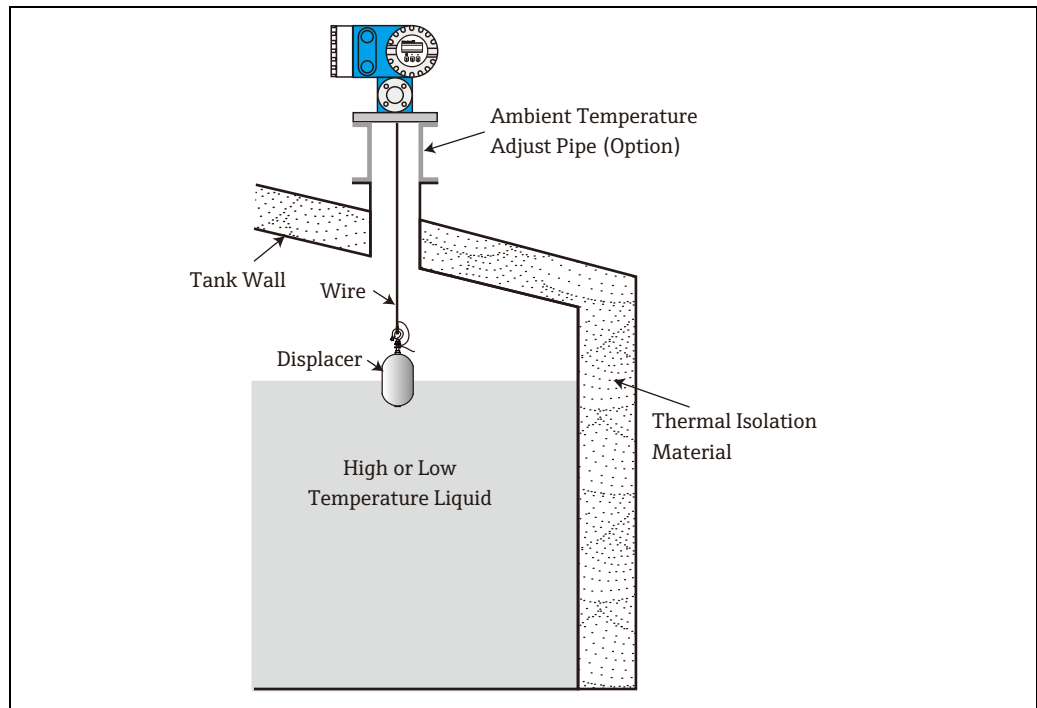

Figure 3: Thermal Isolation

NOTICE

The temperature of the flange and the internal temperature of the drum compartment:
 -20 (or -40) $\leq T \leq 60^{\circ}\text{C}$

6 Applied Standards

The following standards are effective for NMS5.

- EN 13463-1: 2009
- EN 60079-0: 2012
- EN 60079-1: 2007
- EN 60079-11: 2012
- EN 60079-26: 2007

7 Declaration of Conformity

With this Declaration of Conformity, Endress+Hauser Japan ensures that the product conforms to the regulations of the European EMC Directive 89/336/ECC and Directive 94/9/EC. Proof of conformity is given by the standards listed in the Declaration of Conformity.



Endress+Hauser
People for Process Automation

15001

Declaration of Conformity

Endress+Hauser Yamanashi Co., Ltd.
862-1 Mitsukunugi, Sakaigawa-cho, Fuefuki-shi,
Yamanashi Prefecture, 406-0846 Japan
 Assume sole responsibility standing that the product
 Level Gauge "Proservo" NMS53x Series
 Type NMS5-.....

Explosion Proof Certification Number:
 KEMA 05 ATEX 2071

Applied European Directives:
 EMC-Directive 2004/108/EC
 Ex-Directive 94/9/EC

PE-Directive 97/23/EC (only NMS536; NMS5-6.....)
 Applied conformity assessment procedure: Module A

To which this declaration relates is in conformity with the following standards.

EN61326-1	(1997:A1,1998:A2,2001)			
EN13463-1	(2009)	EN60079-0	(2012)+A11:2013	EN60079-1 (2007)
EN60079-11	(2012)	EN60079-26	(2007)	

Quality System was inspected by
 TÜV NORD CERT GmbH Notify Body Number: 0044

First period for CE marking 1999

Yamanashi, 17 March 2015
 (Place and Date)

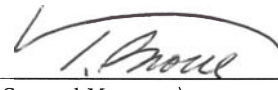

(General Manager)

Figure 4: Declaration of Conformity

www.addresses.endress.com
