



# Certificate of Compliance

**Certificate:** 1132623 (LR 82598)

**Master Contract:** 160686

**Project:** 2567317

**Date Issued:** November 5, 2012

**Issued to:** Endress + Hauser Flowtec AG

Kagenstrasse 7  
Reinach, Basel Land 4153  
Switzerland  
Attention: Utz Dette

*The products listed below are eligible to bear the CSA Mark shown with adjacent indicators 'C' and 'US' for Canada and US or with adjacent indicator 'US' for US only or without either indicator for Canada only.*



*Aisha Sreenath*

**Issued by:** Aisha Sreenath

## **PRODUCTS**

**CLASS 2258 03** - PROCESS CONTROL EQUIPMENT - Intrinsically Safe and Non - Incendive Systems - For Hazardous Locations

**Class I, Zone 1, Group IIC:**

**Class I, Division 1, Groups A, B, C and D; Class II, Division 1, Groups E, F and G; Class III; Type 4X:**

• PROMASS 40/80/83/84A/E/F/H/I/M/O/P/S/X\*\*\_\*\*\*\*\*N/O\*\*\*\*\*+### Mass Flowmeter. Input rated 16-62Vdc, 20-55Vac, 85-260Vac, 50/60Hz, 15VA. Relay contacts rated 42Vdc/100mA and 30Vac/500mA. Explosion-proof with Intrinsically Safe sensor circuits and signal output circuits, Temperature Codes and Maximum Ambient Temperatures per Control Drawing FES0049. Dual Seal Device.

• CNGmass DCI 8\*F\*\*\_\*\*\*\*\*M/N/8\*\*\*\*\*+### Mass Flowmeter. Input rated 16-62Vdc, 20-55Vac, 85-260Vac, 50/60Hz, 15VA. Relay contacts rated 42Vdc/100mA and 30Vac/500mA. Explosion-proof with Intrinsically Safe sensor circuits and signal output circuits, Temperature Codes and Maximum Ambient Temperatures per Control Drawing FES0151. Dual Seal Device.



**Certificate:** 1132623 (LR 82598)

**Master Contract:** 160686

**Project:** 2567317

**Date Issued:** November 5, 2012

- 
- Cubemass DCI 8C\*\*\*-C3/84\*\*\*\*\*+##\*# Mass Flowmeter. Input rated 16-62Vdc, 20-55Vac, 85-260Vac, 50/60Hz, 15VA. Relay contacts rated 42Vdc/100mA and 30Vac/500mA. Explosion-proof with Explosion-proof with Intrinsically Safe sensor circuits and signal output circuits, Temperature Codes and Maximum Ambient Temperatures per Control Drawing FES0152. Dual Seal Device.

Note: The asterisk “\*” in the above model suffixes may be any number or letter representing specific options. The suffix “\*\*\*” in the model Series represents any combination or multiple of double number and/or letter; may be “+” or “#”.

**Class I, Zone 1, Group IIB+H2:**

**Class I, Division 1, Groups B, C and D; Class II, Division 1, Groups E, F and G; Class III; Type 4X:**

- PROMASS 40/80/83/84A/E/F/H/I/M/O/P/S/X\*\*\_\*\*\*\*\*N/O\*\*\*\*\*+##\*# Mass Flowmeter. Input rated 16-62Vdc, 20-55Vac, 85-260Vac, 50/60Hz, 15VA. Relay contacts rated 42Vdc/100mA and 30Vac/500mA. Explosion-proof with Intrinsically Safe sensor circuits and signal output circuits, Temperature Codes and Maximum Ambient Temperatures per Control Drawing FES0049. FACTORY SEALED. Dual Seal Device.

- CNGmass DCI 8\*F\*\*\_\*\*\*\*\*M/N/8\*\*\*\*\*+##\*# Mass Flowmeter. Input rated 16-62Vdc, 20-55Vac, 85-260Vac, 50/60Hz, 15VA. Relay contacts rated 42Vdc/100mA and 30Vac/500mA. Explosion-proof with Intrinsically Safe sensor circuits and signal output circuits, Temperature Codes and Maximum Ambient Temperatures per Control Drawing FES0151. FACTORY SEALED. Dual Seal Device.

- Cubemass DCI 8C\*\*\*-C3/84\*\*\*\*\*+##\*# Mass Flowmeter. Input rated 16-62Vdc, 20-55Vac, 85-260Vac, 50/60Hz, 15VA. Relay contacts rated 42Vdc/100mA and 30Vac/500mA. Explosion-proof with Intrinsically Safe sensor circuits and signal output circuits, Temperature Codes and Maximum Ambient Temperatures per Control Drawing FES0152. FACTORY SEALED. Dual Seal Device.

Note: The asterisk “\*” in the above model suffixes may be any number or letter representing specific options. The suffix “\*\*\*” in the model Series represents any combination or multiple of double number and/or letter; may be “+” or “#”.



**Certificate:** 1132623 (LR 82598)

**Master Contract:** 160686

**Project:** 2567317

**Date Issued:** November 5, 2012

---

**Class I, Zone 1, Group IIB:**

**Class I, Division 1, Groups C and D; Class II, Division 1, Groups E, F and G; Class III; Type 4X:**

- PROMASS 40/80/83/84A/E/F/H/I/M/O/P/S/X\*\*\_\*\*\*\*\*P\*\*\*\*\*+### Mass Flowmeter. Input rated 16-62Vdc, 20-55Vac, 85-260Vac, 50/60Hz, 15VA. Relay contacts rated 42Vdc/100mA and 30Vac/500mA. Explosion-proof with Intrinsically Safe sensor circuits and signal output circuits, Temperature Codes and Maximum Ambient Temperatures per Control Drawing FES0049. FACTORY SEALED. Dual Seal Device.

Note: The asterisk “\*” in the above model suffixes may be any number or letter representing specific options. The suffix “\*\*” in the model Series represents any combination or multiple of double number and/or letter; may be “+” or “#”.

**Class I, Zone 2, Group IIC:**

**Class I, Division 2, Groups A, B, C and D; Class II, Division 1, Groups E, F and G; Class III; Type 4X:**

- PROMASS 40/80/83/84A/E/F/H/I/M/O/P/S/X\*\*\_\*\*\*\*\*R\*\*\*\*\*+### Mass Flowmeter. Transmitter Input rated 16-62Vdc, 20-55Vac, 85-260Vac, 50/60Hz, 15VA. Transmitter Relay contacts rated 42Vdc/100mA and 30Vac/500mA. Non-incendive circuits, Temperature Codes and Maximum Ambient Temperatures per Control Drawing FES0051. Dual Seal Device.

Note: The asterisk “\*” in the above model suffixes may be any number or letter representing specific options. The suffix “\*\*” in the model Series represents any combination or multiple of double number and/or letter; may be “+” or “#”.

**CLASS 2258 83 - PROCESS CONTROL EQUIPMENT - Intrinsically Safe and Non-Incendive Systems - For Hazardous Locations - CERTIFIED TO U.S. STANDARDS**

**Class I, Division 1, Groups A, B, C and D; Class II, Division 1, Groups E, F and G; Class III; Type 4X:**

- CNGmass DCI 8\*F\*\*\_\*\*\*\*\*M/N/8\*\*\*\*\*+### Mass Flowmeter. Input rated 16-62Vdc, 20-55Vac, 85-260Vac, 50/60Hz, 15VA. Relay contacts rated 42Vdc/100mA and 30Vac/500mA. Explosion-proof with



**Certificate:** 1132623 (LR 82598)

**Master Contract:** 160686

**Project:** 2567317

**Date Issued:** November 5, 2012

---

Intrinsically Safe sensor circuits and signal output circuits, Temperature Codes and Maximum Ambient Temperatures per Control Drawing FES0151. Dual Seal Device.

- Cubemass DCI 8C\*\*\*-C3/84\*\*\*\*\*+###Mass Flowmeter. Input rated 16-62Vdc, 20-55Vac, 85-260Vac, 50/60Hz, 15VA. Relay contacts rated 42Vdc/100mA and 30Vac/500mA. Explosion-proof with Intrinsically Safe sensor circuits and signal output circuits, Temperature Codes and Maximum Ambient Temperatures per Control Drawing FES0152. Dual Seal Device.

Note: The asterisk “\*” in the above model suffixes may be any number or letter representing specific options. The suffix “\*\*\*” in the model Series represents any combination or multiple of double number and/or letter; may be “+” or “#”.

**Class I, Division 1, Groups B, C and D; Class II, Division 1, Groups E, F and G; Class III; Type 4X:**

- CNGmass DCI 8\*F\*\*-\*\*\*\*\*M/N/8\*\*\*\*\*+### Mass Flowmeter. Input rated 16-62Vdc, 20-55Vac, 85-260Vac, 50/60Hz, 15VA. Relay contacts rated 42Vdc/100mA and 30Vac/500mA. Explosion-proof with Intrinsically Safe sensor circuits and signal output circuits, Temperature Codes and Maximum Ambient Temperatures per Control Drawing FES0151. FACTORY SEALED. Dual Seal Device.

- Cubemass DCI 8C\*\*\*-C3/84\*\*\*\*\*+###Mass Flowmeter. Input rated 16-62Vdc, 20-55Vac, 85-260Vac, 50/60Hz, 15VA. Relay contacts rated 42Vdc/100mA and 30Vac/500mA. Explosion-proof with Intrinsically Safe sensor circuits and signal output circuits, Temperature Codes and Maximum Ambient Temperatures per Control Drawing FES0152. FACTORY SEALED. Dual Seal Device.

Note: The asterisk “\*” in the above model suffixes may be any number or letter representing specific options. The suffix “\*\*\*” in the model Series represents any combination or multiple of double number and/or letter; may be “+” or “#”.

**APPLICABLE REQUIREMENTS**

CSA Std C22.2 No. 0-M1991 - General Requirements - Canadian Electrical Code

ANSI/ISA-12.27.01-2003 - Requirements for Process Sealing Between Electrical Systems and Flammable or Combustible Process Fluids

CSA Std C22.2 No. 25-1966 - Enclosures for Use in Class II, Groups E, F and G Hazardous Locations

CSA Std C22.2 No. 30-M1986 - Explosion-Proof Enclosures for Use in Class I Hazardous Locations

CAN/CSA-C22.2 No. 94-M91 - Special Purpose Enclosures



**Certificate:** 1132623 (LR 82598)

**Master Contract:** 160686

**Project:** 2567317

**Date Issued:** November 5, 2012

---

CSA Std C22.2 No. 142-M1987 - Process Control Equipment

CAN/CSA-C22.2 No. 157-92 - Intrinsically Safe and Non-Incendive Equipment for Use in Hazardous Locations

CSA Std C22.2 No. 213-M1987 - Non-Incendive Electrical Equipment for Use in Class I, Division 2 Hazardous Locations

FM 3600, November 1998 - Electric Equipment for use in Hazardous Locations General Requirement

FM 3610, January 2010 - Intrinsically Safe Apparatus and Associated Apparatus for Use in Class I, II, and III, Division 1, Hazardous Locations

FM 3615, August 2006 - Explosionproof Electrical Equipment General Requirements

FM 3810, January 2005 - Electrical Equipment for Measurement, Control and Laboratory Use



## Supplement to Certificate of Compliance

**Certificate:** 1132623

**Master Contract:** 160686

*The products listed, including the latest revision described below, are eligible to be marked in accordance with the referenced Certificate.*

### Product Certification History

Project	Date	Description
2567317	November 5, 2012	Update to cover minor revision to connector pin assignment on Control Drawing.
2458350	September 14, 2011	Update to cover model suffixes correction.
2443425	August 12, 2011	Update to include certified sensors type Promass X and Promass O.
2411683	April 14, 2011	Update to cover optional Ethernet I/O options, minor documents revision as per E+H Technical Document 16th Revision.
2224663	January 12, 2010	Update to include mass flowmeters CNGmass DCI 8D** and Cubemass DCI 8C** for CSA c/us marking, remove sensors drawing and minor drawings revisions.
1997636	February 19, 2008	Update to include Amplifier v14, dwgs revisions and alt. glass cover for G05
1832956	January 21, 2008	Enclosure G12 model for hazardous locations. Legacy no. 82598
1978934	January 17, 2008	Update to cover Dual Seal Marking and minor dwgs revision
1832928	November 6, 2007	Update to Report 1132623 to add alternate enclosure G12 model for hazardous locations and minor drawings revision.
1860455	January 23, 2007	Update to cover alt. Commodul C14, exciter coils and report revisions - I.S.
1849742	November 21, 2006	Update to cover alt. sensors feed-through
1832929	October 14, 2005	Addition of alternate enclosure G12 model for hazardous locations. Legacy no. 82598
1722394	October 14, 2005	Update to cover typographical error on sensor.
1696390	September 12, 2005	Update to include alternative sensors Promass I DN51 and I DN80.
1607313	November 15, 2004	Update to report to cover minor drawings revisions - I.S. Hazardous Locations
1569253	August 24, 2004	Update to cover minor drawings revisions and G02 Feed-through for installation in Cl. I, Div. 1, Groups BCD Haz Loc (Legacy no. 82598)
1451217	September 25, 2003	Mass Flowmeters for Hazardous Locations - Update of 160686-1132623(Last Project 160686-1388808)

### History

1388808 December 11, 2002 Update to cover:1. New Commodul C10 (active/passive).2. -40°C version for Class I Div.2, Class II Div 1, Class III.3. Fieldbus connector for Class I Div 2.4. New order code.5. Sensor Promass F for pressures up to 125 bar.6. Revised drawings.

1325457 August 8, 2002 Update to cover:1. Inclusion of Promass 40E from Report 1130308.2. Addition of Promass E DN8-50 for measuring system Promass 8.3. Remote version of Promass E.4. New Sensor Promass H DN50.5. Revised and new drawings.



**Certificate:** 1132623

**Master Contract:** 160686

1278845 March 5, 2002 Update to cover:1. New Sensor Promass F DN 150.2. New Sensor Promass H DN8 - DN40.3. Revised construction of exciter coils for Promass M DN80 A-D version and Promass F DN80/100 A-D version.4. Alternative Connection Cable 6Li9YFCY for remote version.5. Revised drawings.6. Additional damping coil on internal conductors.7. Optional Printed Circuit Board Coating "Peters" Type SL 13.9N).8. New Version (Promass 84).

1204567 June 11, 2001 Update to cover:1. Change of relay rating from 60Vdc to 42Vdc.2. Revised drawings.

1132623 December 19, 2000 Original Certification.

### Hazardous Locations

Class I Division 1 Groups ABCD or Class I Zone 1 Groups IIC and Class II and III Division 1 Groups EFG

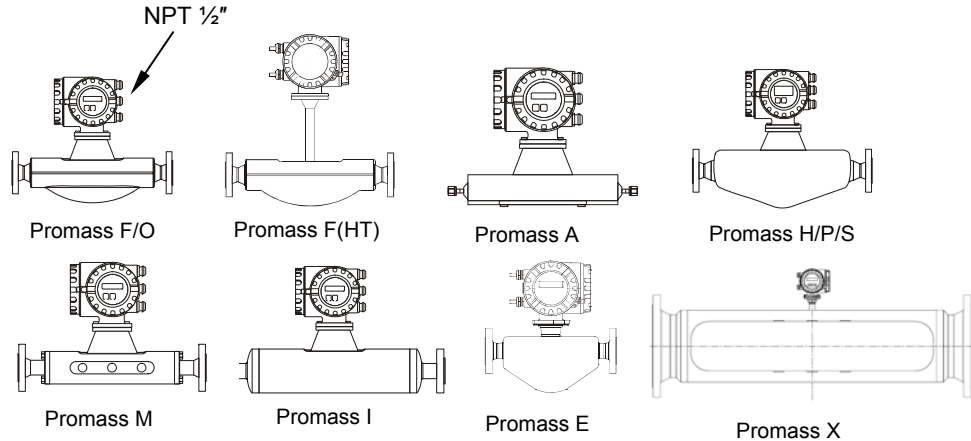

**WARNING: SUBSTITUTION OF COMPONENTS MAY IMPAIR INTRINSIC SAFETY.**

**Notes:**

- Control room equipment shall not use or generate more than 250 V rms.
- Caution: Use supply wires suitable for 5 °C above ambient temperature, but at least for 80 °C / 176°F.
- Install per Canadian Electrical Code.
- Class II Group G: The surface temperature of the apparatus cannot exceed 165 °C / 329°F. The user must limit the process temperature for Group G to 140°C.
- Transmitter enclosures Proline G02 and G12 are explosionproof for use in Cl. I Div. 1 Groups A, B, C, D and dust-ignitionproof for Cl. II, III Div. 1 Groups E, F, G
- Transmitter enclosures PROline G02 and G12 are factory sealed for use in Cl. I Div. 1 Groups B, C, D. A conduit seal is not required.
- Sensor circuits intrinsically safe for Cl. I, II, III Div. 1 Group A, B, C, D, E, F, G except limited versions of
  - Promass E/M DN80 (sensor version Group C-D)
  - Promass I DN41/50/51/80 (sensor version Group C-D)
  - Promass F/F(HT)/O DN80/100/150/250 (sensor version Group C-D)
  - Promass H/P/S DN50 (sensor version Group C-D)
  - Promass X DN350 (sensor version Group C-D)
 which are only suitable for Cl. I, II, III Div. 1 Group C, D, E, F, G
- The minimum medium temperature is -50°C (-40°C for Promass E)
- Install all Intrinsically Safe Circuits per Canadian Electrical Code Part I Section 18 and Appendix F.
- The following Sensors are Dual Seal devices in accordance with ANSI/ISA-12.27.01-2003: Promass A, F, F(HT), H, O, P, S and X. Promass E is a Dual Seal device if the optional rupture disk is present.

Temperature table	max. medium temperature [°C]								
	T6	T5	T4A	T4	T3A	T2C	T2B	T2	T1
<b>Ta = 45°C:</b>									
Promass E DN8/15/25/40/50	45	100	120	130	140	140	140	140	140
Promass P/S DN8	45	65	85	100	140	185	200	200	200
<b>Ta = 50°C:</b>									
Promass M DN8/15/25/40/50/80	50	60	85	105	150	150	150	150	150
Promass F DN8/15/25/40	55	70	85	100	150	185 <sup>)</sup>	200 <sup>)</sup>	200 <sup>)</sup>	200 <sup>)</sup>
Promass F DN50/80/100/150/250	60	70	85	105	150	185 <sup>)</sup>	200 <sup>)</sup>	200 <sup>)</sup>	200 <sup>)</sup>
Promass O DN 80/100/150/250	60	70	85	105	150	185 <sup>)</sup>	200 <sup>)</sup>	200 <sup>)</sup>	200 <sup>)</sup>
Promass I DN8/15/16/25	60	95	95	110	150	150	150	150	150
Promass I DN26/40/41/50/51/80	70	85	105	120	150	150	150	150	150
Promass H DN8	50	65	85	100	140	185	200	200	200
Promass H DN15/25/40/50	60	75	100	115	160	200	200	200	200
Promass P/S DN8	---	65	85	100	140	185	200	200	200
Promass P/S DN15/25	50	75	100	115	160	200	200	200	200
Promass P/S DN40	55	75	100	115	160	200	200	200	200
Promass P/S DN50	60	75	95	110	155	200	200	200	200
Promass X DN350	60	70	85	105	150	185 <sup>)</sup>	200 <sup>)</sup>	200 <sup>)</sup>	200 <sup>)</sup>
<b>Ta = 60°C:</b>									
Promass A DN1/2/4	60	95	115	130	140	200	200	200	200
Promass M DN8/15/25/40/50/80	---	60	85	100	100	100	100	100	100
Promass F DN8/15/25/40	55	70	85	100	150 <sup>)</sup>	185 <sup>)</sup>	200 <sup>)</sup>	200 <sup>)</sup>	200 <sup>)</sup>
Promass F DN50/80/100/150/250	60	70	85	100	150 <sup>)</sup>	185 <sup>)</sup>	200 <sup>)</sup>	200 <sup>)</sup>	200 <sup>)</sup>
Promass O DN80/100/150/250	60	70	85	100	150 <sup>)</sup>	185 <sup>)</sup>	200 <sup>)</sup>	200 <sup>)</sup>	200 <sup>)</sup>
Promass I DN8/15/16/25	60	95	95	110	150 <sup>)</sup>	150 <sup>)</sup>	150 <sup>)</sup>	150 <sup>)</sup>	150 <sup>)</sup>
Promass I DN26/40/41/50/51/80	70	85	105	120	150 <sup>)</sup>	150 <sup>)</sup>	150 <sup>)</sup>	150 <sup>)</sup>	150 <sup>)</sup>
Promass H DN8	50	65	85	100	140	185 <sup>)</sup>	200 <sup>)</sup>	200 <sup>)</sup>	200 <sup>)</sup>
Promass H DN15/25/40/50	60	75	100	115	160	200 <sup>)</sup>	200 <sup>)</sup>	200 <sup>)</sup>	200 <sup>)</sup>
Promass E DN8/15/25/40/50	---	100	120	130	140	140	140	140	140
Promass E DN80	60	75	95	110	140	140	140	140	140
Promass F(HT) DN25/50/80	70	85	100	115 <sup>)</sup>	160 <sup>)</sup>	205 <sup>)</sup>	235 <sup>)</sup>	275 <sup>)</sup>	350 <sup>)</sup>
Promass P/S DN8	---	65	85	100	140	185 <sup>)</sup>	200 <sup>)</sup>	200 <sup>)</sup>	200 <sup>)</sup>
Promass P/S DN15/25/40	---	75	100	115	160	200 <sup>)</sup>	200 <sup>)</sup>	200 <sup>)</sup>	200 <sup>)</sup>
Promass P/S DN50	60	75	95	110	155	200 <sup>)</sup>	200 <sup>)</sup>	200 <sup>)</sup>	200 <sup>)</sup>
Promass X DN350	60	70	85	100	150 <sup>)</sup>	185 <sup>)</sup>	200 <sup>)</sup>	200 <sup>)</sup>	200 <sup>)</sup>

Device shall not be installed in such way that the transmitter enclosure is located above the sensor.  
 Tm min. is -50°C for Promass A/F/F(HT)/H/I/M/O/P/S/X; Ta min. is -40°C; Tm min. is -40°C for Promass E; Ta min. is -40°C

Communication or other options	Control Drawing
I/O option = F,H,J,Q	see FES 0049 - 0001
I/O option = G,K	see FES 0049 - 0002
I/O option = S,T	see FES 0049 - 0004
I/O option = R,U	see FES 0049 - 0005
Promass 40/80/83/84 E DN80 (optional version)	see FES 0163

Aenderungen:	F	06.10.04/MDI	L	20.03.08/BDA	Alle gesetzlichen Urheberrechte vorbehalten. Diese Zeichnung darf ohne unsere Genehmigung weder vervielfältigt werden noch dritten Personen und Konkurrenzfirmen zugänglich gemacht werden.	<b>Mat.-Nr. 71147430</b>  Ersatz für: Ersteller: FES / <b>ID 1089</b> FILE:
	G	04.08.05/SCHK	M	12.08.09/SCHK		
	H	15.08.06/BDA	N	05.08.11/SCHK		
	J	08.08.07/PAM				
	K	05.09.07/BDA				

CSA Control Drawing Div. 1 / Zone 1  
 Class I Zone 1  
 Compact Version  
 Promass 40/80/83/84 A/E/F/H/I/M/O/P/S/X

Gezeichnet	09.10.00	Bn
Geprüft		
Ex-geprüft	05.08.11	SCHK
Gesehen		



### Hazardous Locations

Class I Division 1 Groups ABCD or Class I Zone 1 Groups IIC  
and Class II and III Division 1 Groups EFG

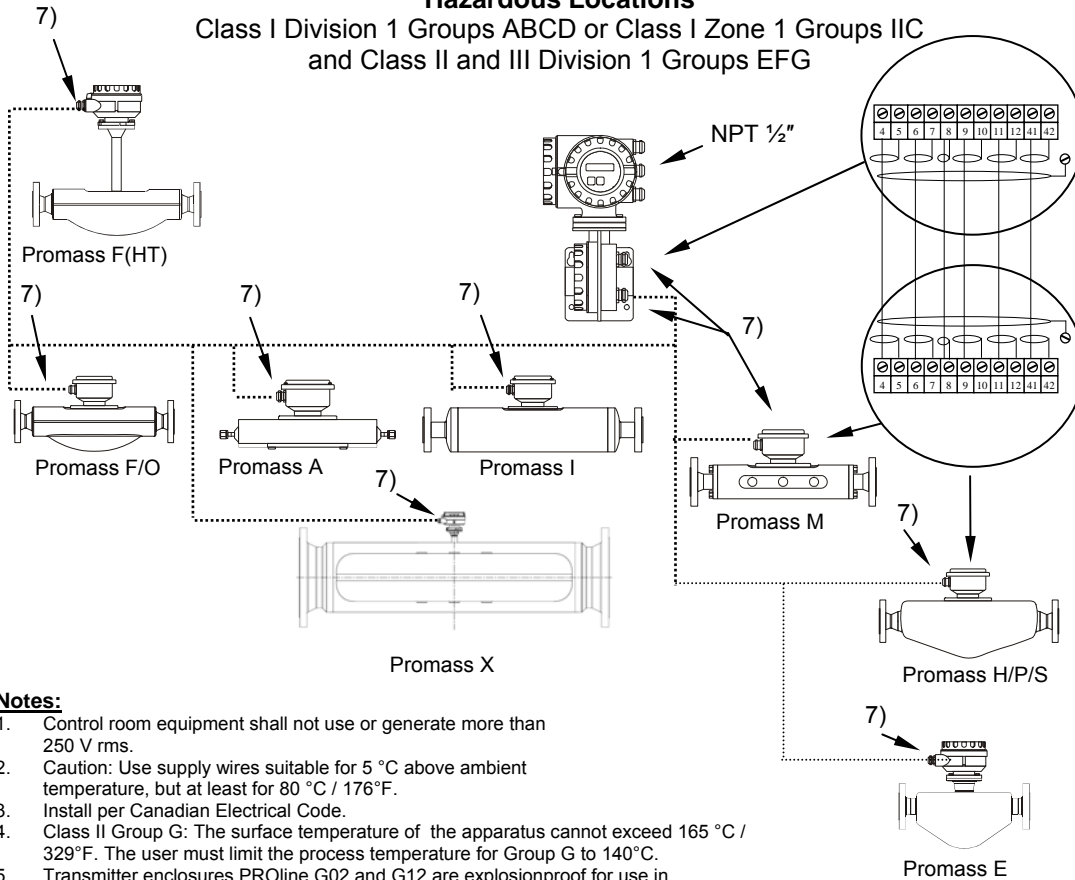

**Notes:**

- Control room equipment shall not use or generate more than 250 V rms.
- Caution: Use supply wires suitable for 5 °C above ambient temperature, but at least for 80 °C / 176°F.
- Install per Canadian Electrical Code.
- Class II Group G: The surface temperature of the apparatus cannot exceed 165 °C / 329°F. The user must limit the process temperature for Group G to 140°C.
- Transmitter enclosures PROline G02 and G12 are explosionproof for use in Cl. I Div. 1 Groups A, B, C, D and dust-ignitionproof for Cl. II, III Div. 1 Groups E, F, G
- Transmitter enclosures PROline G02 and G12 are factory sealed for use in Cl. I Div. 1 Groups B, C, D. A conduit seal is not required.
- Sensor circuits intrinsically safe for Cl. I, II, III Div. 1 Group A, B, C, D, E, F, G except a limited version of
  - Promass E/M DN80 (sensor version Group C-D)
  - Promass I DN41/50/51/80 (sensor version Group C-D)
  - Promass F/F(HT)/O DN80/100/150/250 (sensor version Group C-D)
  - Promass H/P/S DN50 (sensor version Group C-D)
  - Promass X DN350 (sensor version Group C-D)
 which are only suitable for Cl. I, II, III Div. 1 Group C, D, E, F, G
- Allowed cable glands: NPT 1/2", G 1/2", M20x1.5 or PG13.5
- A sensor which was connected to a Promass 60/63/64 transmitter can also be installed to a Promass 8. transmitter. For this case this control drawing is relevant for safe use, except the minimum ambient temperature which is limited to -20°C
- Install all Intrinsically Safe Circuits per Canadian Electrical Code Part I Section 18 and Appendix F.
- The following Sensors are Dual Seal devices in accordance with ANSI/ISA-12.27.01-2003: Promass A, E, F, F(HT), H, O, P, S and X. Promass E is a Dual Seal device if the optional rupture disk is present.

Temperature table	max. medium temperature [°C]								
	T6	T5	T4A	T4	T3A	T2C	T2B	T2	T1
<b>Ta = 45 °C</b>									
Promass E DN25/40/50	45	100	120	130	140	140	140	140	140
Promass P/S DN8	45	65	85	100	140	185	200	200	200
<b>Ta = 50 °C</b>									
Promass P/S DN8	---	65	85	100	140	185	200	200	200
Promass P/S DN15/25	50	75	100	115	160	200	200	200	200
Promass P/S DN40	55	75	100	115	160	200	200	200	200
<b>Ta = 60 °C</b>									
Promass A DN1/2/4	60	95	115	130	140	200	200	200	200
Promass M DN8/15/25/40/50/80	50	60	85	105	150	150	150	150	150
Promass F DN8/15/25/40	55	70	85	100	150	185	200	200	200
Promass F DN50/80/100/150/250	60	70	85	105	150	185	200	200	200
Promass O DN80/100/150/250	60	70	85	105	150	185	200	200	200
Promass I DN8/15/16/25	60	95	95	110	150	150	150	150	150
Promass I DN26/40/41/50/51/80	70	85	105	120	150	150	150	150	150
Promass H DN8	50	65	85	100	140	185	200	200	200
Promass H DN15/25/40/50	60	75	100	115	160	200	200	200	200
Promass E DN8/15/25/40/50	---	100	120	130	140	140	140	140	140
Promass E DN80	60	75	95	110	140	140	140	140	140
Promass F(HT) DN25/50/80	70	85	100	115	160	205	235	275	350
Promass P/S DN8	---	65	85	100	140	185	200	200	200
Promass P/S DN15/25/40	---	75	100	115	160	200	200	200	200
Promass P/S DN50	60	75	95	110	155	200	200	200	200
Promass X DN350	60	70	85	105	150	185	200	200	200

The ambient temperature is -40°C ... +60°C for the transmitter and -40°C ... +60°C for the sensor.

The minimum medium temperature is -50°C . A special version of Promass A/F/F(HT)/H/O/P/S/X is suitable for medium temperatures down to -200°C.  
The minimum medium temperature for Promass E is limited to -40 °C.

**WARNING: SUBSTITUTION OF COMPONENTS MAY IMPAIR INTRINSIC SAFETY.**

Aenderungen:	F	06.10.04/MDI	L	20.03.08/BDA	Alle gesetzlichen Urheberrechte vorbehalten. Diese Zeichnung darf ohne unsere Genehmigung weder vervielfältigt werden noch dritten Personen und Konkurrenzfirmen zugänglich gemacht werden.	<b>Mat.-Nr. 71147430</b>  Ersatz für: Ersteller: FES / <b>ID 1089</b> FILE:
	G	04.08.05/SCHK	M	12.08.09/SCHK		
	H	15.08.06/BDA	N	05.08.11/SCHK		
	J	08.08.07/PAM				
	K	05.09.07/BDA				

**CSA Control Drawing Div. 1 / Zone 1**  
**Class I Zone 1**  
**Remote Version**  
**Promass 40/80/83/84 A/E/F/H/I/M/O/P/S/X**

Gezeichnet	09.10.00	Bn
Geprüft		
Ex-geprüft	05.08.11	SCHK
Gesehen		

**HAZARDOUS LOCATIONS**

- Cl. I Div. 1 Groups A,B,C,D
- Cl. I Zone 1 Group IIC
- Cl. I Div. 2 Group A,B,C,D
- Cl. I Zone 2 Group IIC
- Cl. II, III Div. 1 Group E,F,G

**NON HAZARDOUS LOCATIONS**

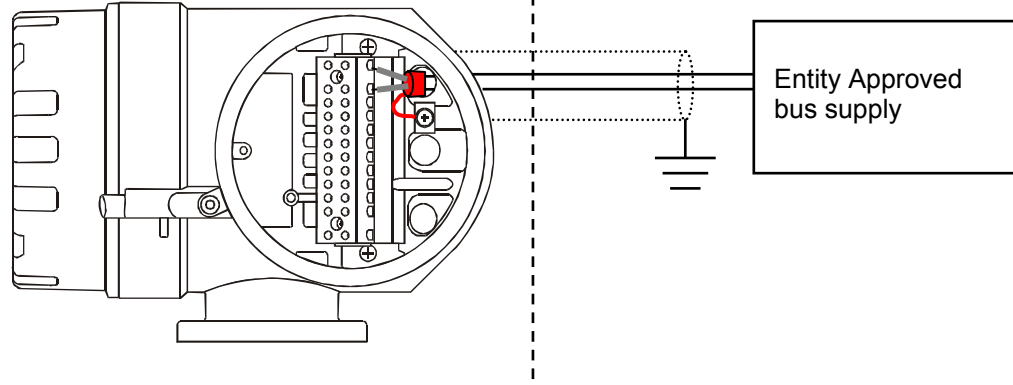

**Notes:**

**Intrinsically safe signal output:**

- 1) Wire all intrinsically safe circuits per Canadian Electrical Code respecting the Explosionsproof Integrity of the enclosure.
- 2) **WARNING:** SUBSTITUTION OF COMPONENTS MAY IMPAIR INTRINSIC SAFETY.
- 3) Control room equipment may not use or generate more than 250 V rms.

**Type: Promass 8\*\* \*-\*\*\*\*\*F+###**

**Terminals: 26 (+), 27 (-) (Profibus PA):**

Passive intrinsically safe PROFIBUS PA circuit:  
For connecting the intrinsically safe circuit (PROFIBUS PA) according to the FISCO-CONCEPT see FES 0049-0003

**Nonintrinsically safe signal output:**

- 4) Wire all intrinsically safe circuits per Canadian Electrical Code respecting the Explosionsproof Integrity of the enclosure
- 5) **WARNING:** EXPLOSION HAZARD - SUBSTITUTION OF COMPONENTS MAY IMPAIR SUITABILITY FOR CLASS I, DIVISION 1.
- 6) Control room equipment may not use or generate over 250 Vrms.

**Type: Promass 8\*\* \*-\*\*\*\*\*H+###**

**Terminals 26 (+),27 (-) (PROFIBUS PA)**

V 9...32V; I = 12mA

**Type: Promass 8\*\* \*-\*\*\*\*\*J+### (PROFIBUS DP)**

**Promass 8\*\* \*-\*\*\*\*\*Q+### (MODBUS RS)**

**Terminals 24 (+5V),25 (GND), 26 (DPA/RSA), 27 (DPB/RSB)**

Terminals: +5V, GNO, DPA, DPB

V = 5 V, I = 100 mA

Aenderungen:	F	06.10.04/MDI	L	20.03.08/BDA	Alle gesetzlichen Urheberrechte vorbehalten. Diese Zeichnung darf ohne unsere Genehmigung weder vervielfältigt werden noch dritten Personen und Konkurrenzfirmen zugänglich gemacht werden.	<b>Mat.-Nr. 71147430</b>  Ersatz für: Ersteller: FES / <b>ID 1089</b> FILE:
	G	04.08.05/SCHK	M	12.08.09/SCHK		
	H	15.08.06/BDA	N	05.08.11/SCHK		
	J	08.08.07/PAM				
	K	05.09.07/BDA				

CSA Control Drawing Div. 1 / Zone 1  
Promass 40/80/83/84 A/E/F/H/I/M/O/P/S/X  
PROFIBUS PA / IS installation  
PROFIBUS PA / DP or MODBUS RS non-IS installation

Gezeichnet	09.10.00	Bn
Geprüft		
Ex-geprüft	05.08.11	SCHK
Gesehen		



Flowtec AG, Kägenstrasse 7, CH-4153 Reinach BL1, Postfach

**FES0049-0001N**

**HAZARDOUS LOCATIONS**

- Cl. I Div. 1 Groups A,B,C,D
- Cl. I Zone 1 Group IIC
- Cl. I Div. 2 Group A,B,C,D
- Cl. I Zone 2 Group IIC
- Cl. II, III Div. 1 Group E,F,G

**NON HAZARDOUS LOCATIONS**

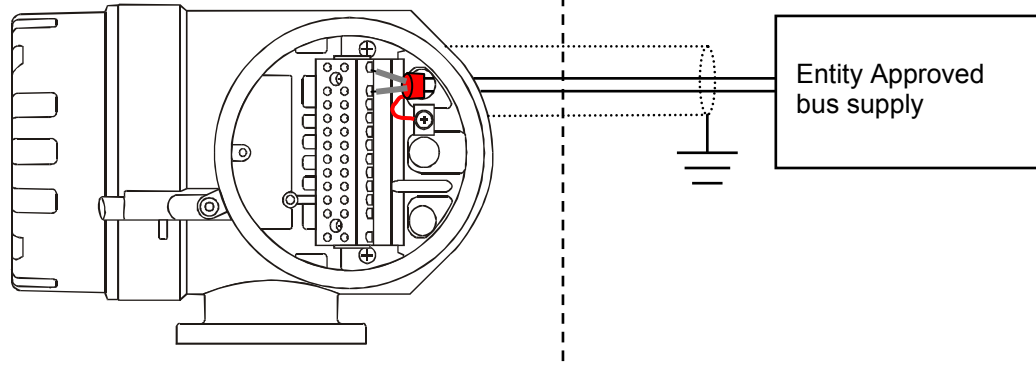

**Notes:**

**Intrinsically safe signal output:**

- 1) Wire all intrinsically safe circuits per Canadian Electrical Code respecting the Explosionsproff Integrity of enclosure.
- 2) **WARNING:** SUBSTITUTION OF COMPONENTS MAY IMPAIR INTRINSIC SAFETY.
- 3) Control room equipment may not use or generate more than 250 Vrms.

**Type: Promass 8\*\* \*\_\*\*\*\*\*G+###**

**Terminals: 26, 27 (Foundation Fieldbus):**

Intrinsically safe circuit:

$V_{max} / U_i$	$I_{max} / I_i$	$P_{max} / P_i$	$C_i$	$L_i$
30 V	600 mA	8.5 W	$\leq 5$ nF	$\leq 10$ $\mu$ H

Connect to entity approved associated apparatus with

$I_{sc}, I_t$  or  $I_o \leq I_{max}$  or  $I_i$  and

$V_{oc}, V_t$  or  $U_o \leq V_{max}$  or  $U_i$

( $P_o \leq P_{max}$  or  $P_i$ )

Cable parameters for Intrinsic Safety:

$$C_{cable} \leq C_a / C_o - \sum C_i$$

$$L_{cable} \leq L_a / L_o - \sum L_i \text{ or}$$

$$L/R_{cable} \leq L/R_{Associated Apparatus} \text{ and } L_i \text{ of each I.S. apparatus } \leq 10 \mu\text{H}$$

Alternatively the intrinsically safe circuit ( Fieldbus Foundation) can be connected according to the FISCO – Concept ( see FES 0049–0003 ).

**Nonintrinsically safe signal output:**

- 4) Wire all intrinsically safe circuits per Canadian Electrical Code respecting Explosionsproof Integrity of the enclosure.
- 5) **WARNING:** EXPLOSION HAZARD - SUBSTITUTION OF COMPONENTS MAY IMPAIR SUITABILITY FOR CLASS I, DIVISION 1.
- 6) Control room equipment may not use or generate over 250 Vrms.

**Type: Promass 8\*\* \*\_\*\*\*\*\*K+###**

**Terminals 26,27 (FIELDBUS FOUNDATION NON I.S.)**

V 9...32V ; I = 12mA

Aenderungen:	F 06.10.04/MDI	L 20.03.08/BDA	Alle gesetzlichen Urheberrechte vorbehalten. Diese Zeichnung darf ohne unsere Genehmigung weder vervielfältigt werden noch dritten Personen und Konkurrenzfirmen zugänglich gemacht werden.	<b>Mat.-Nr. 71147430</b>
	G 04.08.05/SCHK	M 12.08.09/SCHK		Ersatz für:
	H 15.08.06/BDA	N 05.08.11/SCHK		Ersteller: FES / <b>ID 1089</b>
	J 08.08.07/PAM			FILE:
	K 05.09.07/BDA			

CSA Control Drawing Div. 1 / Zone 1  
 Promass 40/80/83/84 A/E/F/H/I/M/O/P/S/X  
 Fieldbus Foundation IS installation  
 Fieldbus Foundation non-IS installation

Gezeichnet	09.10.00	Bn
Geprüft		
Ex-geprüft	05.08.11	SCHK
Gesehen		



Flowtec AG, Kägenstrasse 7, CH-4153 Reinach BL1, Postfach

FES0049-0002N

**FISCO CONCEPT**

The FISCO Concept allows interconnection of intrinsically safe apparatus to associated apparatus not specially examined in such combination. The criteria for interconnection is that the voltage ( $U_i$  or  $V_{max}$ ), the current ( $I_i$  or  $I_{max}$ ), and the power ( $P_i$  or  $P_{max}$ ) which intrinsically safe apparatus can receive and remain intrinsically safe, considering faults, must be equal or greater than the voltage ( $U_o$  or  $V_{oc}$ ), the current ( $I_o$  or  $I_{sc}$ ) and the power ( $P_o$  or  $P_{max}$ ) levels which can be delivered by the associated apparatus, considering faults and applicable factors. In addition, the maximum unprotected capacitance ( $C_i$ ) and inductance ( $L_i$ ) of each apparatus (other than the termination) connected to the fieldbus must be less than or equal to 5 nF and 10 μH respectively.

In each segment only one active device, normally the associated apparatus, is allowed to provide the necessary energy for the fieldbus system. The voltage  $U_o$  or  $V_{oc}$  of the associated apparatus is limited to a range of 14V to 24Vd.c. All other equipment connected to the bus cable has to be passive, meaning that they are not allowed to provide energy to the system, except a leakage current of 50μA for each connected device. Separately powered equipment needs a galvanic isolation to assure that the intrinsically safe fieldbus circuit remains passive.

The cable used to interconnect the devices needs to have the parameter in the following range:

Loop Resistance  $R'$  : 15...150 Ohm/km  
 Inductance per unit length  $L'$  : 0.4...1 mH/km  
 Capacitance per unit length  $C'$  : 80...200 nF

$C' = C' \text{ line/line} + 0.5 C' \text{ line/screen}$ , if both lines are floating, or  
 $C' = C' \text{ line/line} + C' \text{ line/screen}$ , if the screen is connected to one line  
 Length of trunk cable: ≤ 1000 m  
 Length of spur cable: ≤ 30 m  
 Length of splice: ≤ 1 m

At each end of the trunk cable an approved infallible line termination with following parameters is suitable:

$R = 90...100 \text{ Ohm}$        $C = 0...2.2 \mu\text{F}$

One of the allowed terminations might already be integrated in the associated apparatus. The number of passive apparatus connected to the bus segment is not limited due to I. S. reasons. If the above rules are respected, up to a total length of 1000 m (sum of trunk and all spur cables), the inductance and the capacitance of the cable will not impair the intrinsic safety of the installation.

Notes:

Intrinsically safe Class I, Div.1, Groups A,B,C,D

- Approved associated apparatus must be installed in accordance with manufacturers instructions.
- CSA approved associated apparatus must meet the following parameters:  
 $U_o$  or  $V_{oc} \leq U_i$  ( $V_{max}$ ) and  $I_o$  or  $I_{sc} \leq I_i$  ( $I_{max}$ ) and  $P_o$  or  $P_{max} \leq P_i$  ( $P_{max}$ )
- The maximum non-hazardous area voltage must not exceed 250V
- Wire all intrinsically safe circuits per Canadian Electrical Code respecting the Explosionsproof integrity of the enclosure
- Multiple earthing of screen is allowed only, if high integrity equipotential system is realized between the points of bonding (see drawing No. FES 0014).
- Caution: Use only supply wires suitable for 5°C above surrounding temperature.
- Warning : Substitution of components may impair intrinsic safety.
- The polarity for connection PA+ (26) and PA- (27) is of no importance due to an internal rectifier.

**HAZARDOUS (CLASSIFIED) LOCATION**

Class I, Division 1, Groups A,B,C,D  
 Class II, Division 1, Groups E,F,G  
 Class III, Division 1

**NONHAZARDOUS LOCATION**

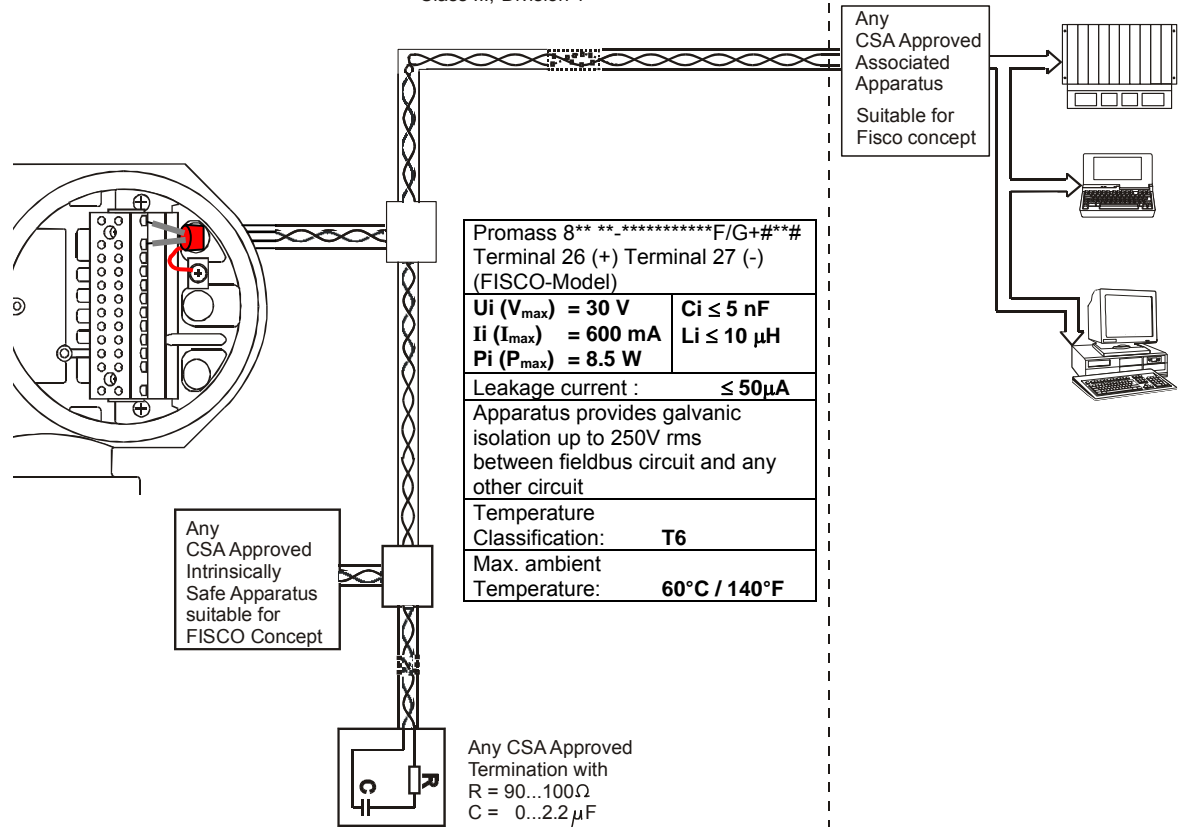

Anderungen:	F 06.10.04/MDI	L 20.03.08/BDA	Alle gesetzlichen Urheberrechte vorbehalten. Diese Zeichnung darf ohne unsere Genehmigung weder vervielfältigt werden noch dritten Personen und Konkurrenzfirmen zugänglich gemacht werden.	<b>Mat.-Nr. 71147430</b>  Ersatz für: Ersteller: FES / <b>ID 1089</b> FILE:
	G 04.08.05/SCHK	M 12.08.09/SCHK		
	H 15.08.06/BDA	N 05.08.11/SCHK		
	J 08.08.07/PAM			
	K 05.09.07/BDA			

**CSA Control Drawing Div. 1 / Zone 1**  
**Promass 40/80/83/84 A/E/F/H/I/M/O/P/S/X**  
**Intrinsically safe PROFIBUS PA**  
**Foundation Fieldbus**  
**FISCO-Concept**



Flowtec AG, Kägenstrasse 7, CH-4153 Reinach BL1, Postfach

Gezeichnet	09.10.00	Bn
Geprüft		
Ex-geprüft	05.08.11	SCHK
Gesehen		

**FES0049-0003N**

**NON HAZARDOUS LOCATION**

**HAZARDOUS LOCATION**

Cl. I, Zone 1 IIC  
 Cl. I, II, III Div. 1 Group A,B,C,D,E,F,G or  
 Cl. I Div. 2 Group A,B,C,D, and Cl.II,III Div.1 Group E,F,G

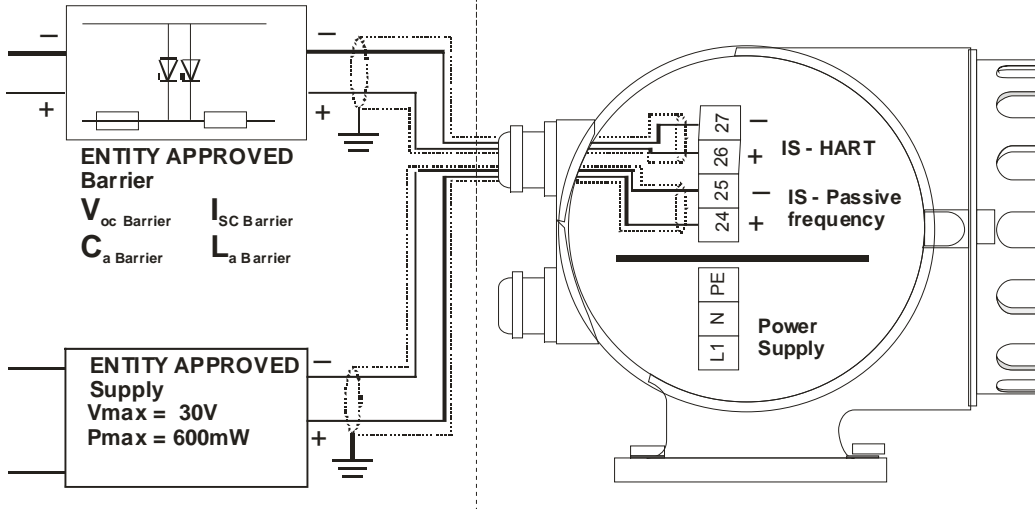

**Notes:**

- 1) Use supply wires suitable for 5 °C above surrounding ambient, but at least for 80°C/176°F
- 2) **Intrinsically safe signal output:** Install all intrinsically safe circuits per Canadian Electrical Code respecting the Explosionproof Integrity of the enclosure
- 3) **WARNING:** SUBSTITUTION OF COMPONENTS MAY IMPAIR INTRINSIC SAFETY.
- 4) Control room equipment may not use or generate more than 250 Vrms.

**Type: Promass 8\*\* \*\_\*\*\*\*\*S+###**

**Promass 40\* \*\_\*\*\*\*\*S+###**

**Terminals: 26, 27 (HART current output):**

Active intrinsically safe circuit:

$V_{oc} / U_o$	$I_{sc} / I_o$	$P_{max} / P_o$	$C_a / C_o$	$L_a / L_o$
21.8 V	90 mA	490 mW	0.15 µF	4.1 mH

$V_{max} / U_i$	$I_{max} / I_i$	$P_{max} / P_i$	$C_i$	$L_i$
30 V	10 mA	300 mW	6 nF	0

Cable parameters for Intrinsic Safety:

$$C_{cable} \leq 0.15 \mu F \quad \text{if } V_{oc} \text{ (of Barrier)} \leq 21.8 V$$

$$C_{cable} \leq C_a \text{ Barrier} - 6 nF \quad \text{if } V_{oc} \text{ (of Barrier)} \geq 21.8 V$$

$$L_{cable} \leq 4.1 mH$$

**Terminals 24, 25 (Passive intrinsically safe circuit):**

$V_{max} / U_i$	$I_{max} / I_i$	$P_{max} / P_i$	$C_i$	$L_i$
30 V	300 mA	600mW	6 nF	0

Entity approved supply must meet the following requirements:

$$V_{oc}, V_t \text{ or } U_o \leq V_{max} \quad P_{max} \text{ or } P_o \leq P_{max} / P_i$$

Cable parameters for Intrinsic Safety:

$$C_{cable} \leq C_a (C_o) - 6nF \quad L_{cable} \leq L_a (L_o)$$

**Type: Promass 8\*\* \*\_\*\*\*\*\*T+###**

**Promass 40\* \*\_\*\*\*\*\*T+###**

**Terminals: 26, 27 (HART current output):**

Passive intrinsically safe circuit:

$V_{max} / U_i$	$I_{max} / I_i$	$P_{max} / P_i$	$C_i$	$L_i$
30 V	100 mA	1.25 W	6 nF	negligible

Connect to entity approved Barrier with

$$V_{oc}, V_t \text{ or } U_o \leq V_{max} / U_i$$

$$I_{sc}, I_t \text{ or } I_o \leq I_{max} / I_i$$

Cable parameters for Intrinsic Safety:

$$C_{cable} \leq C_a \text{ Barrier or } C_o \text{ Barrier} - 6 nF$$

$$L_{cable} \leq L_a \text{ Barrier or } L_o \text{ Barrier}$$

**Terminals 24, 25 (Passive intrinsically safe circuit):**

$V_{max} / U_i$	$I_{max} / I_i$	$P_{max} / P_i$	$C_i$	$L_i$
30 V	300 mA	600mW	6 nF	0

Entity approved apparatus must meet the following requirements:

$$V_{oc}, V_t \text{ or } U_o \leq V_{max} \quad P_{max} \text{ or } P_o \leq P_{max} / P_i$$

Cable parameters for Intrinsic Safety:

$$C_{cable} \leq C_a (C_o) - 6 nF$$

$$L_{cable} \leq L_a (L_o)$$

Aenderungen:	F	06.10.04/MDI	L	20.03.08/BDA	Alle gesetzlichen Urheberrechte vorbehalten. Diese Zeichnung darf ohne unsere Genehmigung weder vervielfältigt werden noch dritten Personen und Konkurrenzfirmen zugänglich gemacht werden.	<b>Mat.-Nr. 71147430</b>  Ersatz für: Ersteller: FES / ID 1089 FILE:
	G	04.08.05/SCHK	M	12.08.09/SCHK		
	H	15.08.06/BDA	N	05.08.11/SCHK		
	J	08.08.07/PAM				
	K	05.09.07/BDA				

CSA Control Drawing Cl. I, Div. 1			Gezeichnet	09.10.00	Bn
Promass 40/80/83/84 A/E/F/H/I/M/O/P/S/X			Geprüft		
Entity concept Commodul HART IS (Option S/T)			Ex-geprüft	05.08.11	SCHK
			Gesehen		

	Flowtec AG, Kägenstrasse 7, CH-4153 Reinach BL1, Postfach	FES0049-0004N
--	---	---------------

**NON HAZARDOUS LOCATION**

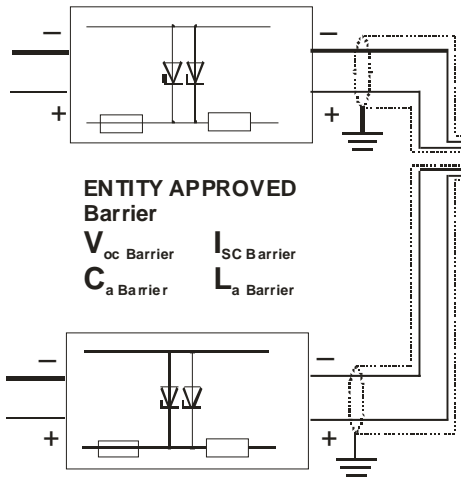

**HAZARDOUS LOCATION**

Cl. I, Zone 1 IIC  
 Cl. I, II, III Div. 1 Group A,B,C,D,E,F,G or  
 Cl. I Div. 2 Group A,B,C,D, and Cl.II,III Div.1 Group E,F,G

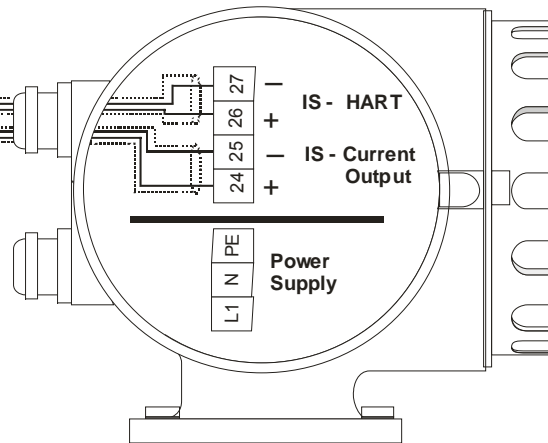

**Notes:**

- 1) Use supply wires suitable for 5 °C above surrounding ambient, but at least for 80°C/176°F
- 2) **Intrinsically safe signal output:** Install all intrinsically safe circuits per Canadian Electrical Code respecting the Explosionproof Integrity of the enclosure
- 3) **WARNING:** SUBSTITUTION OF COMPONENTS MAY IMPAIR INTRINSIC SAFETY.
- 4) Control room equipment may not use or generate more than 250 Vrms.

**Type: Promass 8\*\* \*\_\*\*\*\*\*R+###**

**Promass 40\* \*\_\*\*\*\*\*R+###**

**Terminals: 26, 27 (HART current output):**

**Terminals: 24, 25 (current output):**

**Active:**

$V_{oc} / U_o$	$I_{sc} / I_o$	$P_{max} / P_o$	$C_a / C_o$	$L_a / L_o$
21.8 V	90 mA	490 mW	0.15 µF	4.1 mH

$V_{max} / U_i$	$I_{max} / I_i$	$P_{max} / P_i$	$C_i$	$L_i$
30 V	10 mA	300 mW	6 nF	0

**Cable parameters for Intrinsic Safety:**

- $C_{cable} \leq 0.15 \mu F$  if  $V_{oc} \text{ (of Barrier)} \leq 21.8 V$
- $C_{cable} \leq C_a \text{ Barrier} - 6 nF$  if  $V_{oc} \text{ (of Barrier)} \geq 21.8 V$
- $L_{cable} \leq 4.1 mH$

**Type: Promass 8\*\* \*\_\*\*\*\*\*U+###**

**Promass 40\* \*\_\*\*\*\*\*U+###**

**Terminals: 26, 27 (HART current output)**

**Terminals: 24, 25 (current output)**

**Passive:**

$V_{max} / U_i$	$I_{max} / I_i$	$P_{max} / P_i$	$C_i$	$L_i$
30 V	100 mA	1.25 W	6 nF	negligible

Connect to entity approved Barrier with

$V_{OC}, V_t \text{ or } U_o \leq V_{max} / U_i$

$I_{sc}, I_t \text{ or } I_o \leq I_{max} / I_i$

Cable parameters for Intrinsic Safety:

$C_{cable} \leq C_a \text{ Barrier or } C_o \text{ Barrier} - 6 nF$

$L_{cable} \leq L_a \text{ Barrier or } L_o \text{ Barrier}$

Aenderungen:	F	06.10.04/MDI	L	20.03.08/BDA	Alle gesetzlichen Urheberrechte vorbehalten. Diese Zeichnung darf ohne unsere Genehmigung weder vervielfältigt werden noch dritten Personen und Konkurrenzfirmen zugänglich gemacht werden.	<b>Mat.-Nr. 71147430</b>  Ersatz für: Ersteller: FES / <b>ID 1089</b> FILE:
	G	04.08.05/SCHK	M	12.08.09/SCHK		
	H	15.08.06/BDA	N	05.08.11/SCHK		
	J	08.08.07/PAM				
	K	05.09.07/BDA				

<b>CSA Control Drawing Cl. I, Div. 1</b> Promass 40/80/83/84 A/E/F/H/I/M/O/P/S/X Entity concept Commodul HART IS (Option R/U)	Gezeichnet	09.10.00	Bn
	Geprüft		
	Ex-geprüft	05.08.11	SCHK
	Gesehen		