



Member of the FM Global Group

FM Approvals
1151 Boston Providence Turnpike
P.O. Box 9102 Norwood, MA 02062 USA
T: 781 762 4300 F: 781-762-9375 www.fmapprovals.com

CERTIFICATE OF COMPLIANCE

HAZARDOUS (CLASSIFIED) LOCATION ELECTRICAL EQUIPMENT

This certificate is issued for the following equipment:

T-mass 65Fcc-defghiklmnop. Thermal Mass Flowmeter.

T-mass 65l-ccdefghiklmnop. Thermal Mass Flowmeter.

XP-IS / I / 1 / ABCD / T6 Ta = 60°C — FES0096; Entity*; Type 4X;

XP-IS / 1 / IIC / T6 Ta = 60°C — FES0096; Entity*; Type 4X;

DIP-IS / II, III / 1 / EFG / T6 Ta = 60°C — FES0096; Entity*; Type 4X;

Provides intrinsically safe sensor circuits.

*For Entity Parameters reference relevant control drawings.

cc = Nominal diameter (Type of sensor = F, up to a size of 100 mm / 4")

or Insertion tube length (Type of sensor = I): any double number or letter

d = Material of tube / sensor:

any single number or letter (representing stainless steel or alloy C-22)

e = Process connection (T-mass F: up to a pressure of 40 bar / 580 psi, T-mass I: up to a pressure of 20 bar / 290 psi): any single number or letter

f = Seal: any single number or letter

g = Surface finishing: any single number or letter

h = Calibration: any single number or letter

i = Additional test, Certificate: any single number or letter

k = Approval:N

l = Housing: compact: A, 1, remote: G, H, J, 6, 7, 8.

m = Cable Entry: A, B, or (X - suitable for remote sensor only).

n = Power supply, display, operation: 7, 8, A, B, or (X - suitable for remote sensor only).

o = Software: any single number or letter

p = Signal outputs: A, B, C, D, E, F, G, H, J, K, L, M, N, P, Q,R, S, T, U, V, W, 0, 2, 3, 4, 5, 6, 7, 8, 9 or (X - suitable for remote sensor only).



Member of the FM Global Group

T-mass 65Fcc-defghiklmnop. Thermal Mass Flowmeter.

T-mass 65I-ccdefghiklmnop. Thermal Mass Flowmeter.

NI-ANI / I,II,III / 2 / ABCDEFG / T4 Ta = 60°C — FES0097; NIFW*; Type 4X;
NI-ANI / I / 2 / IIC / T4 Ta = 60 °C – FES0097; NIFW*, Type 4X

* Nonincendive Field Wiring Parameters reference relevant control drawings.

cc = Nominal diameter (Type of sensor = F, up to a size of 100 mm / 4")

or Insertion tube length (Type of sensor = I): any double number or letter

d = Material of tube / sensor

any single number or letter (representing stainless steel or alloy C-22)

e = Process connection (T-mass F: up to a pressure of 40 bar / 580 psi, T-mass I: up to a pressure of 20 bar / 290 psi): any single number or letter

f = Seal: any single number or letter

g = Surface finishing: any single number or letter

h = Calibration: any single number or letter

i = Additional test, Certificate: any single number or letter

k = Approval: R.

l = Housing: compact: A, 1, remote: C, D, E, 3, 4, 5.

m = Cable Entry: A, B, C, or (X - suitable for remote sensor only).

n = Power supply, display, operation: 7, 8, A, B, or (X - suitable for remote sensor only).

o = Software: any single number or letter

p = Signal outputs: A, B, C, D, E, H, J, K, L, M, N, P, Q, V, W, 0, 2, 3, 4, 5, 6, 7, 8, 9, or (X - suitable for remote sensor only).

Special Condition of use:

1) With Nonincendive transducer elements to CL. I, Div.2, GP. A, B, C, D.

Equipment Ratings:

Evaluation for the T-mass 65F series and T-mass 65I series Thermal Mass Flowmeters as Explosionproof for use in Class I, Division 1, Group A, B, C and D; Dust-Ignitionproof for use in Class II, III, Division 1, Group E, F and G indoor/ outdoor hazardous (classified) locations, utilizing Type 4X enclosure with Intrinsically Safe connection to Class I, II, III, Division 1, Groups A, B, C, D, E, F, & G indoor/outdoor hazardous (classified) locations. The installation of the products should be in accordance with Control Drawing FES0096.

Evaluation for the T-mass 65F series and T-mass 65I series Thermal Mass Flowmeters Nonincendive Apparatus for use in Class I, II, III, Division 2, Group A, B, C, D, E, F, & G indoor/ outdoor hazardous (classified) locations, utilizing Type 4X enclosure with Nonincendive Field Wiring connections to Class I, II, III, Division 2, Groups A, B, C, D, E, F, & G indoor/outdoor hazardous (classified) locations. The installation of the products should be in accordance with Control Drawing FES0097. With Nonincendive transducer elements to Class I, Division 2, Group A, B, C, D,

FM Approved for:

Endress + Hauser Flowtec AG
Kägenstraße 7
CH-4153 Reinach BL 1
Switzerland



Member of the FM Global Group

This certifies that the equipment described has been found to comply with the following Approval Standards and other documents:

Class 3600	1998
Class 3610	2010
Class 3611	1999
Class 3615	1989
Class 3810	1989
Including Supplement #1	1995
NEMA 250	1991
ANSI/ISA 12.27.01	2003

Original Project ID: 3024788

Approval Granted: December 23, 2005

Subsequent Revision Reports / Date Approval Amended

Report Number	Date	Report Number	Date
3041673	April 21, 2011		
131004	November 15, 2013		

FM Approvals LLC

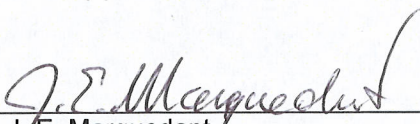

 J.E. Marquedant
 Group Manager, Electrical

15 November 2013
 Date

Hazardous Classified Locations

Class I Div. 2 Groups ABCD T4 – T1; Class I Zone 2 IIC T4 – T1
 Class II Division 1 Groups EFG, Class III

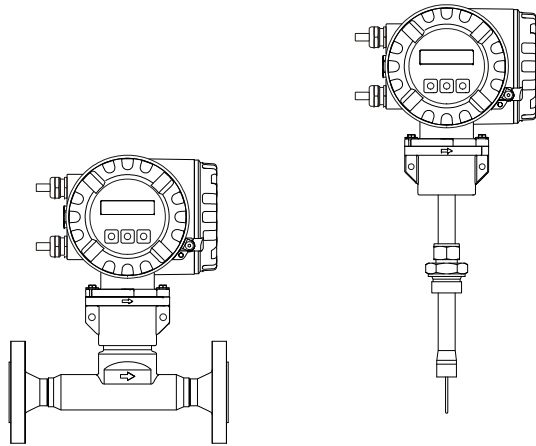

T-mass 6*F

T-mass 6* I

T-mass 6* F / I

NI / I / 2 / ABCD T4 – T1; DIP / II, III / 1 / EFG
 Class I Zone 2 GP IIC T4 – T1

The ambient temperature range depends the version . It is either from -20°C ... +60°C or from -40°C ... +60°C (see your nameplate).

Table for Temperature classes:

	max. medium temperature [°C]					
Ta = 60 °C	T6	T5	T4	T3	T2	T1
T-mass F	—	—	80	80	80	80
T-mass I	—	—	80	80	80	80

Notes:

1. Installation of Transmitter circuit wiring according to NEC using threaded conduit or other wiring methods in accordance with articles 500 to 510.
2. Caution: Use supply wires suitable for 5°C above ambient temperature, but at least for 80°C / 176°F
3. Class II Group G: The surface temperature of the apparatus cannot exceed 165°C / 329°F.
4. Warning: Explosion Hazard – Substitution of components may impair suitability for Class I, Division 2.
5. For Installation of Fieldbus communication circuits of T-mass 6****_*****H /K see sheet 3.
6. The service interface FXA 193 can be connected to the service port of T-mass 6* F/I if the area is known to be non-hazardous. A hazardous atmosphere may be present only inside the measuring tube.

Aenderungen:	A	23.03.07/BDA	F	SD113D/06/en/06.06 71030013 Ersteller: FES / ID 1167 FILE: M:\Zeichng\FES0097\A\FES0097B.doc
	B	08.08.12/BIF	G	
	C		H	
	D		J	
	E		K	

FM Control Drawing Class I Division 2 / Class I Zone 2 Compact version T-mass 6*F / I	Gezeichnet	05.08.2005	UD
	Geprüft		
	Ex-geprüft	08.08.2012	BIF
	Gesehen		



Flowtec AG, Kägenstrasse 7, CH-4153 Reinach BL1, Postfach

FES0097 B

1/4

Hazardous Classified Locations

Class I Div. 2 Groups ABCD T4 – T1; Class I Zone 2 IIC T4 – T1;
Class II Division 1 Groups EFG; Class III

T-mass 6* F / I

NI / I / 2 / ABCD T4 – T1; DIP / II, III / 1 / EFG
Class I Zone 2 IIC T4 – T1

The ambient temperature range depends the version . It is either from -20°C ... +60°C or from -40°C ... +60°C (see your nameplate).

Temperature Class Transmitter: T4 at 60 °C ambient temperature.

Temperature Class Table for sensor:

	max. medium temperature [°C]					
Ta = 60 °C	T6	T5	T4	T3	T2	T1
T-mass F	—	—	80	80	80	80
T-mass I	—	—	80	80	80	80

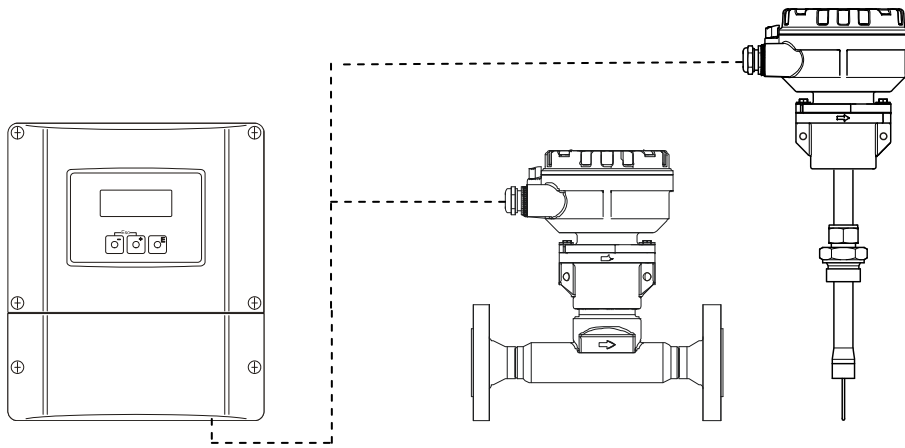

T-mass 6* transmitter

T-mass F

T-mass I

Notes:

1. Installation of circuit wiring according to NEC using threaded conduit or other wiring methods in accordance with articles 500 to 510.
2. Caution: Use wires suitable for 5°C above ambient temperature, but at least for 80°C / 176°F.
3. Class II Group G: The surface temperature of the apparatus cannot exceed 165°C / 329°F.
4. Allowed cable glands for nonincendive field wiring: NPT ½“, G ½“ or M20x1.5
5. Non-incendive field circuit wiring (ANI) when installed with a cable that has the following cable parameters: L_C = 90 μH and C_C = 100 nF . The maximum allowed cable length is 100 m.
6. Warning: Substitution of components may impair suitability for Class I, Div.2.
7. For Installation of Fieldbus communication circuits of T-mass T-mass 6*F*_*****H/K and T-mass 6*I_*****H/K see see sheet 3.
8. The service interface FXA 193 can be connected to the service port of T-mass 6* F/I if the area is known to be non-hazardous. A hazardous atmosphere may be present only inside the measuring tube.

Aenderungen:	A	23.03.07/BDA	F	SD113D/06/en/06.06 71030013 Ersteller: FES / ID 1167 FILE: M:\Zeichng\FES0097\A\FES0097B.doc
	B	08.08.12/BIF	G	
	C		H	
	D		J	
	E		K	

FM Control Drawing Class I Division 2 / Class I Zone 2 Remote version T-mass 6* F / I	Gezeichnet	05.08.2005	UD
	Geprüft		
	Ex-geprüft	08.08.2012	BIF
	Gesehen		

T-mass 6*F*_*****H/K and T-mass 6*I-*****H/K

Non-Hazardous
Classified Location

Hazardous Classified Location

Class I Div. 2 Groups ABCD or
Class I Zone 2 Group IIC

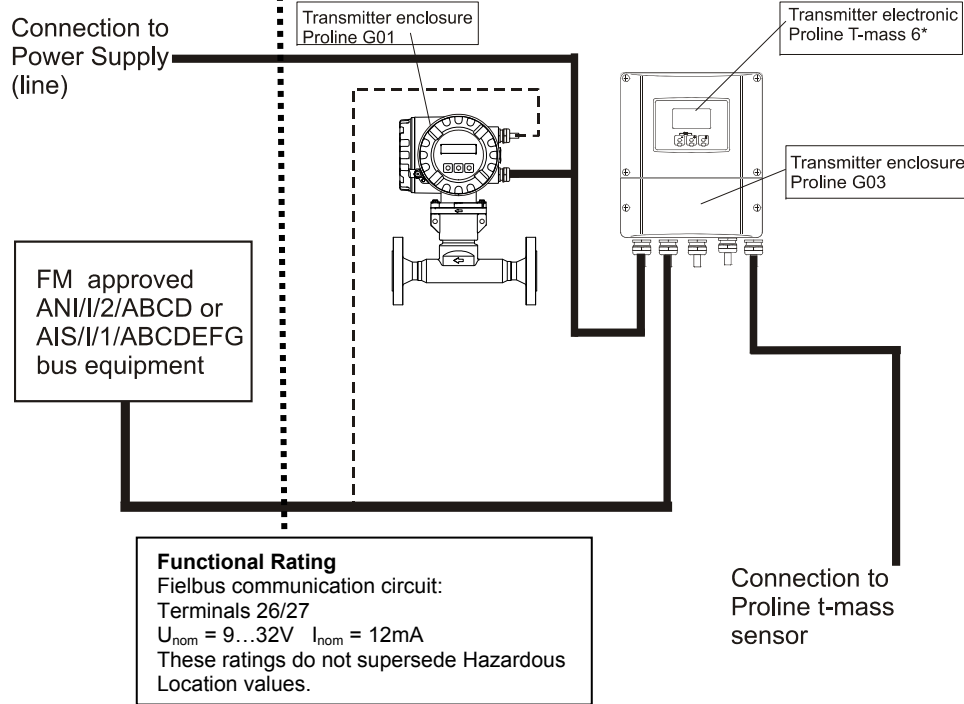

Notes:

- Fieldbus cable connectors are suitable for Class I, Division 2, Groups A, B, C, D if connected to associated nonincendive field wiring or associated apparatus.
 - The Nonincendive Field Wiring Circuit Concept allows interconnection of nonincendive field wiring apparatus with associated nonincendive field wiring apparatus or associated apparatus not specifically examined in combination as a system using any of the wiring methods permitted for unclassified locations, when: $V_{max} \geq V_{oc}$ or V_t , $C_a \geq C_i + C_{cable}$, $L_a \geq L_i + L_{cable}$
Fieldbus communication circuit Terminals 26/27 (current controlled circuit)
- | V_{max} | I_{max} | C_i | L_i |
|-----------|------------|-------|-------|
| 35V | See note 3 | 5nF | 10µH |
- For this current controlled circuit, the parameter I_{max} is not required and need not to be aligned with parameter I_{SC} and I_t of the associated non-incendive field wiring or associated apparatus.
 - Fieldbus communication circuits Terminals (26/27) are suitable for connection according to Fieldbus Nonincendive Concept (FNICO) see sheet 4.

Profibus PA
connector

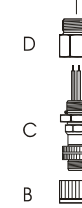
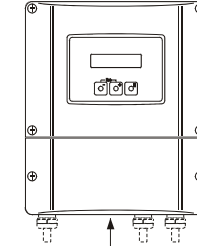
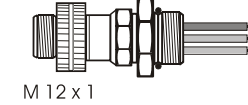
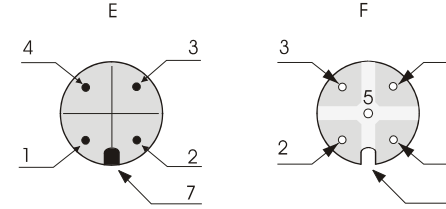

Fieldbus Foundation
connector

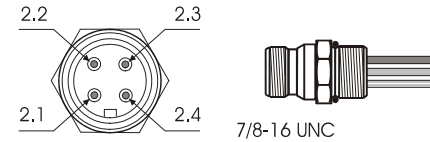

B = Protection cap for connector, C = Fieldbus connector, D = Thread adapter
E = Connector on housing (male), F = Connector (female)

Pin assignment:

Profibus PA

- 1 = Brown wire, PA+ (terminal 26)
- 2 = Not connected
- 3 = Blue wire, PA- (terminal 27)
- 4 = Black wire, ground
- 5 = Female connector not assigned
- 6 = Positioning groove
- 7 = Positioning key

Fieldbus Foundation

- 2.1 = Brown wire, FF+ (terminal 26)
- 2.2 = Blue wire, FF- (terminal 27)
- 2.3 = Grey wire, ground
- 2.4 = Not assigned

A	23.03.07/BDA	F	SD113D/06/en/06.06 71030013 Ersteller: FES / ID 1167 FILE: M:\Zeichng\FES0097\A\FES0097B.doc
B	08.08.12/BIF	G	
C		H	
D		J	
E		K	
FM Control Drawing Cl. I Div. 2 / Zone 2 Fieldbus communication circuits Compact version / Remote version T-mass 6* F / I			Gezeichnet 05.08.2005 UD Geprüft Ex-geprüft 08.08.2012 BIF Gesehen
Flowtec AG, Kägenstrasse 7, CH-4153 Reinach BL1, Postfach			FES0097 B 3/4

FNICO CONCEPT

The FNICO-concept allows interconnection of nonincendive apparatus to associated apparatus not specially examined in such combination. The criteria for interconnection is that the voltage (U_i or V_{max}) which nonincendive apparatus can receive and nonincendive, must be equal or greater than the voltage (U_o , V_{oc} or V_t) levels which can be delivered by the associated apparatus. In addition, the maximum unprotected capacitance (C_i) and inductance (L_i) of each apparatus (other than the termination) connected to the fieldbus must be less than or equal to 5 nF and 20 μ H respectively.

In each segment only one active device, normally the associated apparatus, is allowed to provide the necessary energy for the fieldbus system. The voltage U_o , V_{oc} or V_t of the associated apparatus has to be limited to the range of 14V to 24V. All other equipment connected to the bus cable has to be passive, meaning that they are not allowed to provide energy to the system, except a leakage current of 50 μ A for each connected device. Separately powered equipment needs a galvanic isolation to assure that the nonincendive fieldbus circuit remains passive.

The cable used to interconnect the devices needs to have the parameter in the following range:

Loop Resistance R' :	15...150 Ohm/km
Inductance per unit length L' :	0.4...1 mH/km
Capacitance per unit length C' :	45...200 nF/km

- C' = C' line/line + 0.5 C' line/screen, if both lines are floating, or
- C' = C' line/line + C' line/screen, if the screen is connected to one line
- Length of trunk cable: \leq 1000 m
- Length of spur cable: \leq 60 m
- Length of splice: \leq 1 m

At each end of the trunk cable an approved infallible line termination with following parameters is suitable:

$R = 90...102 \text{ Ohm}$ $C = 0...2.2 \text{ } \mu\text{F}$

One of the allowed terminations might already be integrated in the associated apparatus. The associated apparatus has to be installed within 30m from the end of the trunk cable. The number of passive apparatus connected to the bus segment is not limited due to NI reasons. If the above rules are respected, up to a total length of 1000 m (sum of trunk and all spur cables), the inductance and the capacitance of the cable will not impair the safety of the installation.

Notes:

1. FM approved apparatus with associated nonincendive field wiring apparatus or associated apparatus must be installed with manufacturers instructions.
2. Be aware of multiple earthing of the screen.
3. Caution: Use only supply wires suitable for 5°C above surrounding temperature.
4. The polarity for connection terminals 26 (+) and 27 (-) is of no importance due to an internal rectifier.

HAZARDOUS CLASSIFIED LOCATION

Class I, Division 2, Groups A,B,C,D
 Class II, Division 1, Groups E,F,G
 Class III

NONHAZARDOUS LOCATION

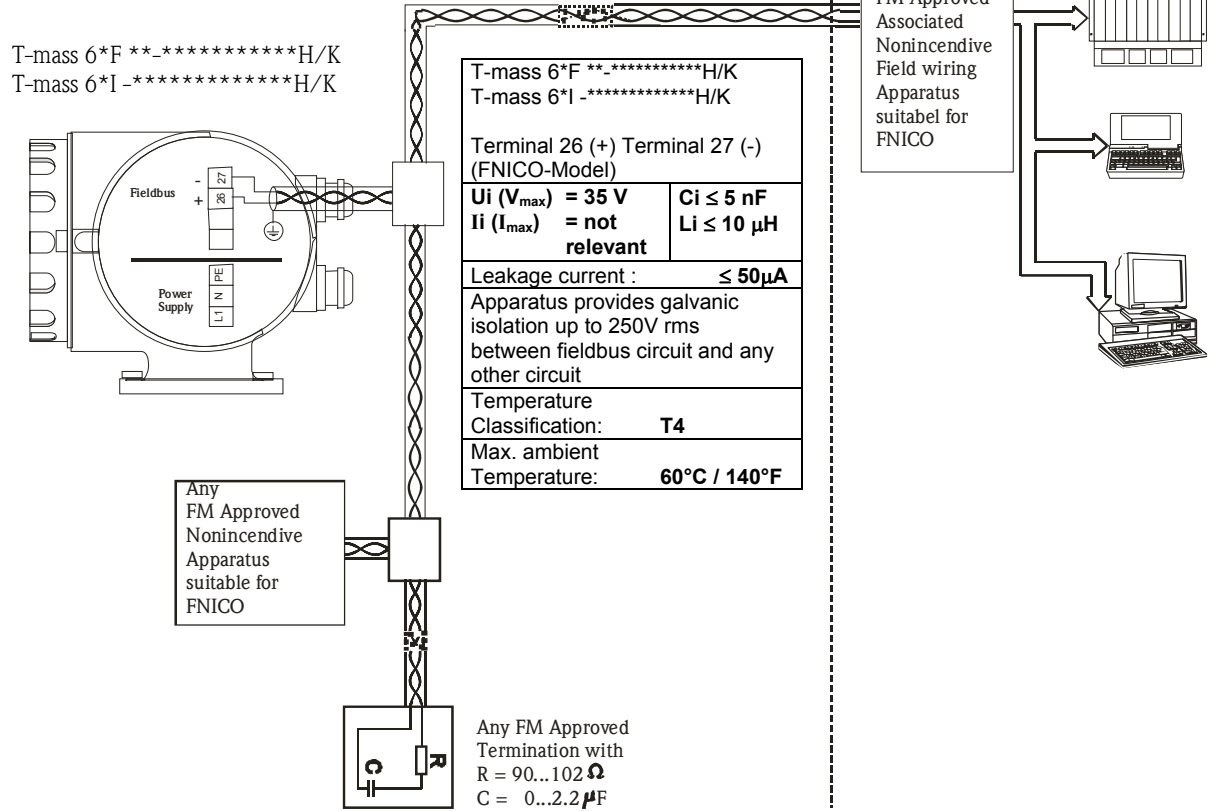

Änderungen:	A	23.03.07/BDA	F	Alle gesetzlichen Urheberrechte vorbehalten. Diese Zeichnung darf ohne unsere Genehmigung weder vervielfältigt werden noch dritten Personen und Konkurrenzfirmen zugänglich gemacht werden.	SD113D/06/en/06.06 71030013 Ersteller: FES / ID 1167 FILE: M:\Zeichng\FES0097\A\FES0097B.doc
	B	08.08.12/BIF	G		
	C		H		
	D		J		
	E		K		

FM Control Drawing Div. 2 / Zone 2 PROFIBUS PA + Foundation Fieldbus FNICO T-mass 6* F / I	Massstab	Gezeichnet	05.08.2005	UD
		Geprüft		
		Ex-geprüft	08.08.2012	BIF
		Gesehen		