

Special Documentation

Proline Promass 80F, 83F, 84F

Supplementary documentation for cryogenic liquids



Application

Cryogenic liquids including

- Nitrogen
- Argon
- Oxygen
- CO₂
- LNG (Liquefied Natural Gas)

Your benefits

- Robust flow measurement at cryogenic temperatures
- Space-saving installation - compact devices requiring no inlet/outlet runs
- Designed for custody transfer - featuring worldwide recognized metrological approvals

Table of contents

Documentation	3
Function and system design	3
Measuring system	3
Input	3
Measuring range	3
Performance characteristics	4
Maximum measured error	4
Repeatability	5
Installation	5
Orientation	5
Process	6
Medium temperature range	6
Pressure-temperature ratings	6
Thermal insulation	7
Mechanical construction	8
Design, dimensions	8
Weight	10
Custody transfer measurement (only Promass 84F)	11
Suitability for custody transfer measurement	11

Documentation

This manual is Special Documentation and is not a substitute for the Operating Instructions and Technical Information supplied with the device.

This document describes the changes and additions and replace or supplement the specifications in the documentation concerned.

For detailed information, refer to the Operating Instructions, Technical Informations and other documentation on the CD-ROM provided or visit "www.endress.com/deviceviewer".

The Special Documentation is an integral part of the following Operating Instructions and Technical Information.

Measuring Device	Operating Instructions				Technical Information
	HART	FOUNDATION Fieldbus	Modbus RS485	PROFIBUS	
Promass 80F	BA00057D	–	–	BA00072D	TI00101D
Promass 83F	BA00059D	BA00065D	BA00107D	BA00063D	
Promass 84F	BA00109D	–	BA00129D	–	TI00103D

This Special Documentation is available:

- On the CD-ROM supplied with the device (depending on the device version ordered)
- In the Download Area of the Endress+Hauser Internet site: www.endress.com → Download

Function and system design

Measuring system

Remote version: transmitter and sensor are mounted physically separate from one another.

Input

Measuring range

Measuring ranges for liquids (non-custody transfer mode)

DN		Range for full scale values (liquids) $\dot{m}_{\min(F)}$ to $\dot{m}_{\max(F)}$	
[mm]	[in]	[kg/h]	[lb/min]
8	$\frac{3}{8}$	0 to 2 000	0 to 73.50
15	$\frac{1}{2}$	0 to 6 500	0 to 238.9
25	1	0 to 18 000	0 to 661.5
40	1 $\frac{1}{2}$	0 to 45 000	0 to 1 654
50	2	0 to 70 000	0 to 2 573
80	3	0 to 180 000	0 to 6 615
100	4	0 to 350 000	0 to 12 860
150	6	0 to 800 000	0 to 29 400
250	10	0 to 2 200 000	0 to 80 850

Measuring ranges for liquids (custody transfer mode)

The following are example data for MI-005 approval (liquids other than water)

DN		Mass flow (liquids) Q_{\min} to Q_{\max}		Smallest measured quantity	
[mm]	[in]	[kg/min]	[lbs/min]	[kg]	[lbs]
8	$\frac{3}{8}$	1.5 to 30	3.3075 to 66.15	0.5	1.10
15	$\frac{1}{2}$	5 to 100	11.025 to 220.5	2	4.41
25	1	15 to 300	33.075 to 661.5	5	11.0
40	$1\frac{1}{2}$	35 to 700	77.175 to 1543.5	20	44.1
50	2	50 to 1000	110.25 to 2205.0	50	110.25
80	3	150 to 3000	330.75 to 6615.0	100	220.50
100	4	200 to 4500	441.00 to 9922.5	200	441.00
150	6	350 to 12000	771.75 to 26460	500	1102.5
250	10	1500 to 35000	3307.5 to 77175	1000	2205.0



Note!

For information about the other approvals see corresponding certificate

Performance characteristics**Maximum measured error**

o.r. = of reading; $1 \text{ g/cm}^3 = 1 \text{ kg/l}$; T = fluid temperature

Base accuracy**Mass flow (cryogenic liquids)**

$\pm 0.35\%$ o.r.

Density (cryogenic liquids)

■ $\pm 0.05 \text{ g/cm}^3$

Zero point stability

Note!

In field zero point confirmation and adjustment may be difficult to realize due to evaporation of the cryogenic fluid. In general, the factory zero point should not be adjusted unless it can be absolutely confirmed that the fluid is completely in the liquid phase inside the flowmeter.

DN		Zero point stability	
[mm]	[in]	[kg/h]	[lb/min]
8	$\frac{3}{8}$	0.030	0.001
15	$\frac{1}{2}$	0.200	0.007
25	1	0.540	0.019
40	$1\frac{1}{2}$	2.25	0.083
50	2	3.50	0.129
80	3	9.00	0.330
100	4	14.00	0.514
150	6	32.00	1.17
250	10	88.00	3.23

Repeatability

Base repeatability

Mass flow (cryogenic liquids)

±0.175% o.r.

Density (cryogenic liquids)

±0.025 g/cm³

Installation

Orientation



Make sure that the direction of the arrow on the nameplate of the sensor matches the direction of flow (direction in which the fluid flows through the pipe).

Vertical (Fig. V)

Recommended orientation with upward direction of flow. When fluid is not flowing, entrained solids will sink down and gases will rise away from the measuring tube. The measuring tubes can be completely drained and protected against solids build-up.

Horizontal (Fig. H1)

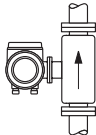
The measuring tubes must be horizontal and beside each other. When installation is correct the transmitter housing is above or below the pipe. Always avoid having the transmitter housing in the same horizontal plane as the pipe. Please note the special installation instructions, in the "Technical Information" document, "Special mounting instructions" section

Vertical	Horizontal, Transmitter head up
 <p style="text-align: right; font-size: small;">a0004572</p> <p><i>Fig. V</i></p>	 <p style="text-align: right; font-size: small;">a0004576</p> <p><i>Fig. H1</i></p>
✓✓	✓✓

✓✓ = Recommended orientation; ✓ = Orientation recommended in certain situations;
 ✗ = Impermissible orientation

Process

Medium temperature range

Sensor

Standard version: -196 to +200 °C (-320 to +392 °F)



Warning!

The maximum differential of the application fluid temperature may not exceed 300 °K.

Pressure-temperature ratings



Warning!

The following pressure-temperature-ratings refer to the entire sensor and not just the process connection.

Flange connection according to EN 1092-1 (DIN 2501)

Flange material: 1.4404 (F316/F316L), Alloy C22

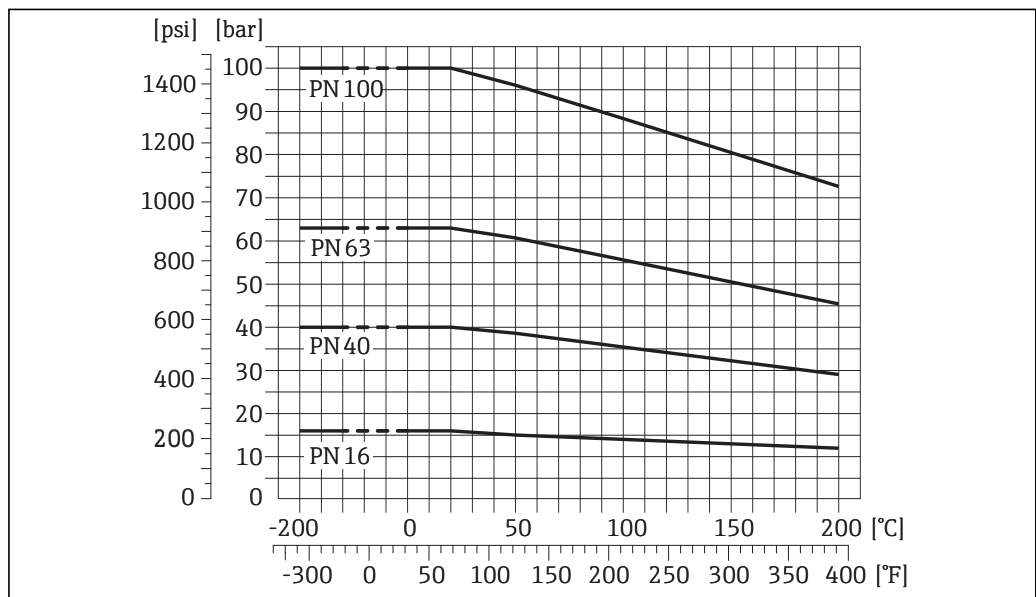

A0024021-EN

Flange connection according to ASME B16.5

Flange material: 1.4404 (F316/F316L), standard version

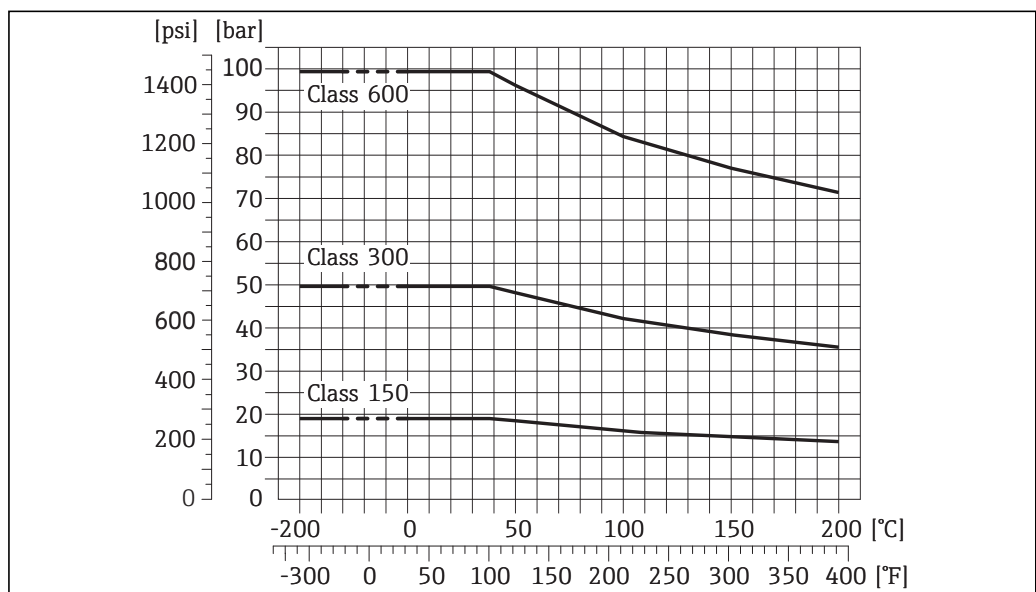

A0017249-EN

Flange connection to JIS B2220

Flange material: 1.4404 (F316/F316L), Alloy C22

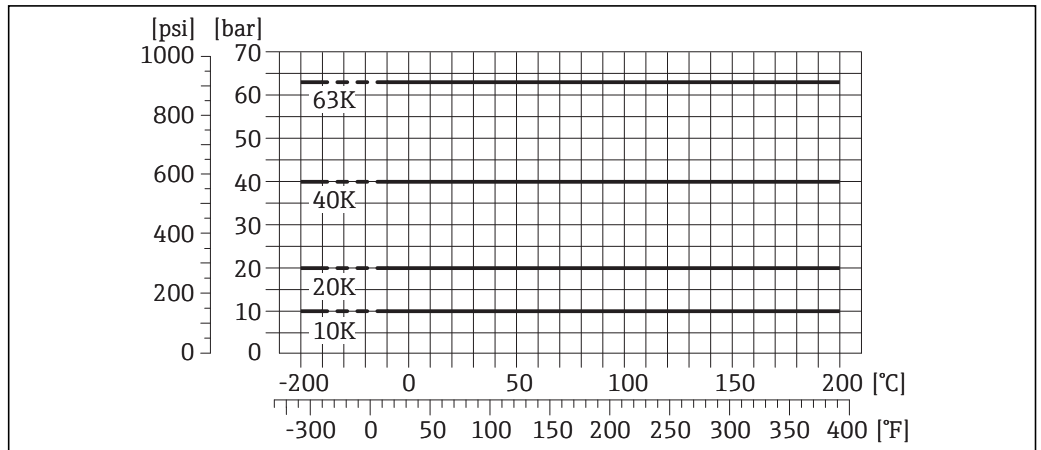

A0024022-EN

Thermal insulation

In general it is not mandatory to insulate the sensor. If the sensor is insulated the maximum thickness of the insulation is 50 mm.

Mechanical construction

Design, dimensions

Transmitter remote version, connection housing (II2G/Zone 1)

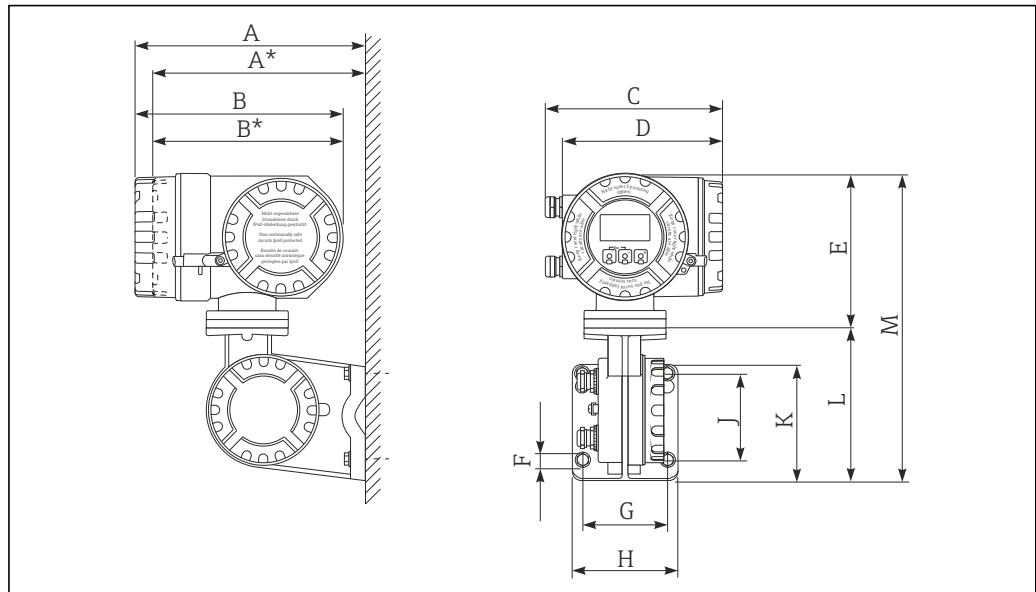

Dimensions in SI units

A	A*	B	B*	C	D	E	F Ø	G	H	J	K	L	M
265	242	240	217	206	186	178	8.6 (M8)	100	130	100	144	170	348

* Blind version (without display)
All dimensions in [mm]

Dimensions in US units

A	A*	B	B*	C	D	E	F Ø	G	H	J	K	L	M
10.4	9.53	9.45	8.54	8.11	7.32	7.01	0.34 (M8)	3.94	5.12	3.94	5.67	6.69	13.7

* Blind version (without display)
All dimensions in [in]

Transmitter remote version, wall-mount housing (none Ex-zone and II3G/Zone 2)

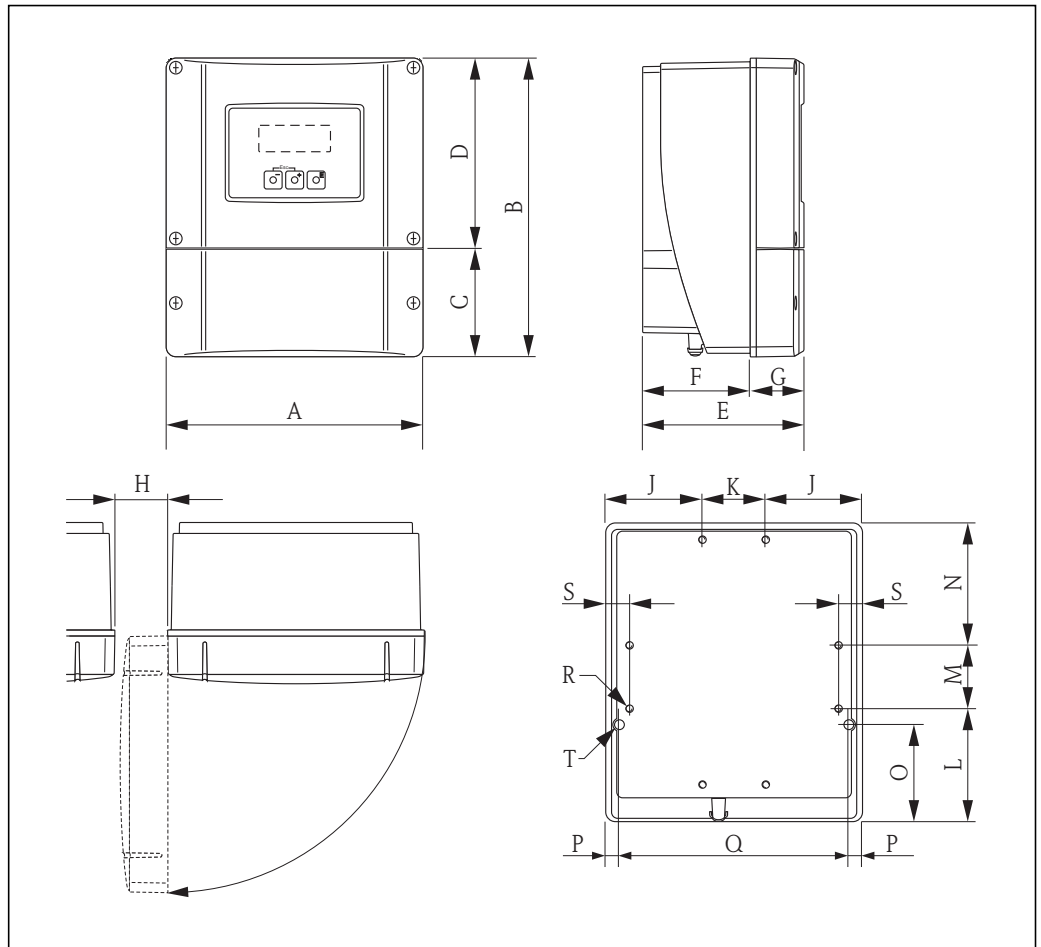

a0001150

Dimensions in SI units

A	B	C	D	E	F	G	H	J	K
215	250	90.5	159.5	135	90	45	> 50	81	53
L	M	N	O	P	Q	R	S	T ¹⁾	
95	53	102	81.5	11.5	192	8 × M5	20	2 × ∅ 6.5	

¹⁾ Securing screw for wall mounting: M6 (screw head max. 10.5 mm)

All dimensions in [mm]

Dimensions in US units

A	B	C	D	E	F	G	H	J	K
8.46	9.84	3.56	6.27	5.31	3.54	1.77	> 1.97	3.18	2.08
L	M	N	O	P	Q	R	S	T ¹⁾	
3.74	2.08	4.01	3.20	0.45	7.55	8 × M5	0.79	2 × ∅ 0.26	

¹⁾ Securing screw for wall mounting: M6 (screw head max. 0.41")

All dimensions in [in]

Sensor remote version, connection housing with an extended neck

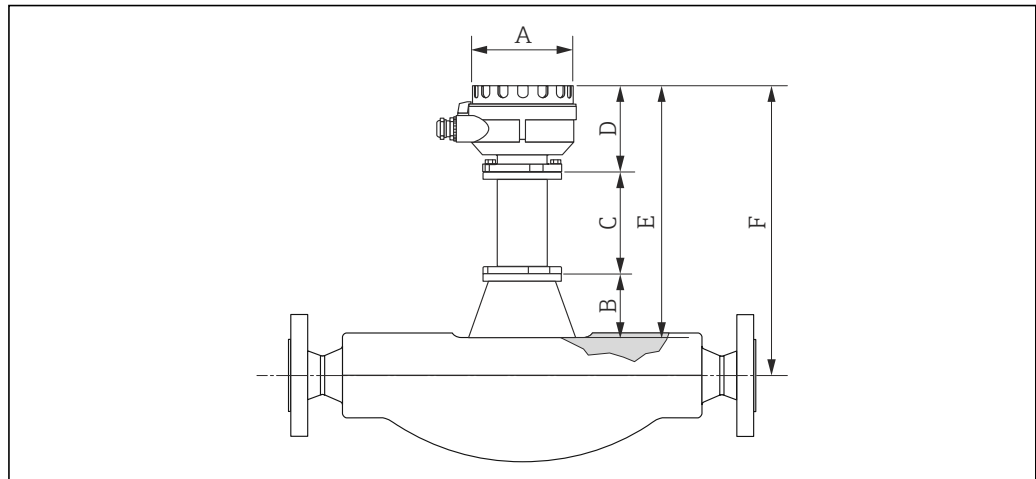

A0024041

Dimensions in SI and US units

DN		A		B		C		D		E		F	
[mm]	[in]	[mm]	[in]	[mm]	[in]	[mm]	[in]	[mm]	[in]	[mm]	[in]	[mm]	[in]
8	3/8"	129	5.08	80	3.15	110	4.33	102	4.02	292	11.5	317	12.48
15	1/2"	129	5.08	80	3.15	110	4.33	102	4.02	292	11.5	317	12.48
25	1"	129	5.08	80	3.15	110	4.33	102	4.02	292	11.5	317	12.48
40	1 1/2"	129	5.08	80	3.15	110	4.33	102	4.02	292	11.5	322	12.68
50	2"	129	5.08	80	3.15	110	4.33	102	4.02	292	11.5	334	13.15
80	3"	129	5.08	80	3.15	110	4.33	102	4.02	292	11.5	356	14.02
100	4"	129	5.08	80	3.15	110	4.33	102	4.02	292	11.5	375	14.76
150	6"	129	5.08	80	3.15	110	4.33	102	4.02	292	11.5	397	15.63
250	10"	129	5.08	80	3.15	110	4.33	102	4.02	292	11.5	441	17.36

For other dimensions and installation lengths of the device, see the "Technical Information" document, "Mechanical construction" section.

Weight

Remote version

- Sensor: see the tables below
- Wall-mount housing: 5 kg (11 lbs)

Weight information in SI units

DN [mm]	8	15	25	40	50	80	100	150	250 ¹⁾
Remote version	9	10	12	17	28	53	94	152	398

¹⁾With 10" according to ASME B16.5 Cl 300 flanges
All values (weight) refer to devices with EN/DIN PN 40 flanges.
Weight information in [kg].

Weight information in US

DN [in]	3/8	1/2	1	1 1/2	2	3	4	6	10 ¹⁾
Remote version	20	22	26	37	62	117	207	335	877

¹⁾ With 10" according to ASME B16.5 Cl 300 flanges
All values (weight) refer to devices with EN/DIN PN 40 flanges.
Weight information in [lbs].

Custody transfer measurement (only Promass 84F)

Suitability for custody transfer measurement

MID approval, Annex MI-005 (liquids other than water)

The device is qualified to OIML R117-1 and OIML R81

Sensor	DN		OIML R117-1/MID Evaluation Certificate (Europe)		
Promass	[mm]	[in]	Liquids other than water		
F	8 to 250	3/8 to 10	Mass	Volume	Density
			YES	NO	NO

NTEP approval

The measuring instrument is qualified in accordance with the National Type Evaluation Program (NTEP) Handbook 44 ("Specifications and Tolerances and other Technical Requirements for Weighing and Measuring Devices").

Please see corresponding certificate for details.

MC approval

The measuring instrument is qualified in accordance with "The Draft Ministerial Specifications - Mass Flow Meters" (1993-09-21).

Please see corresponding certificate for details.

www.addresses.endress.com
