

Description of Device Functions

Proline t-mass 65

Modbus RS485

Thermal Mass Flowmeter

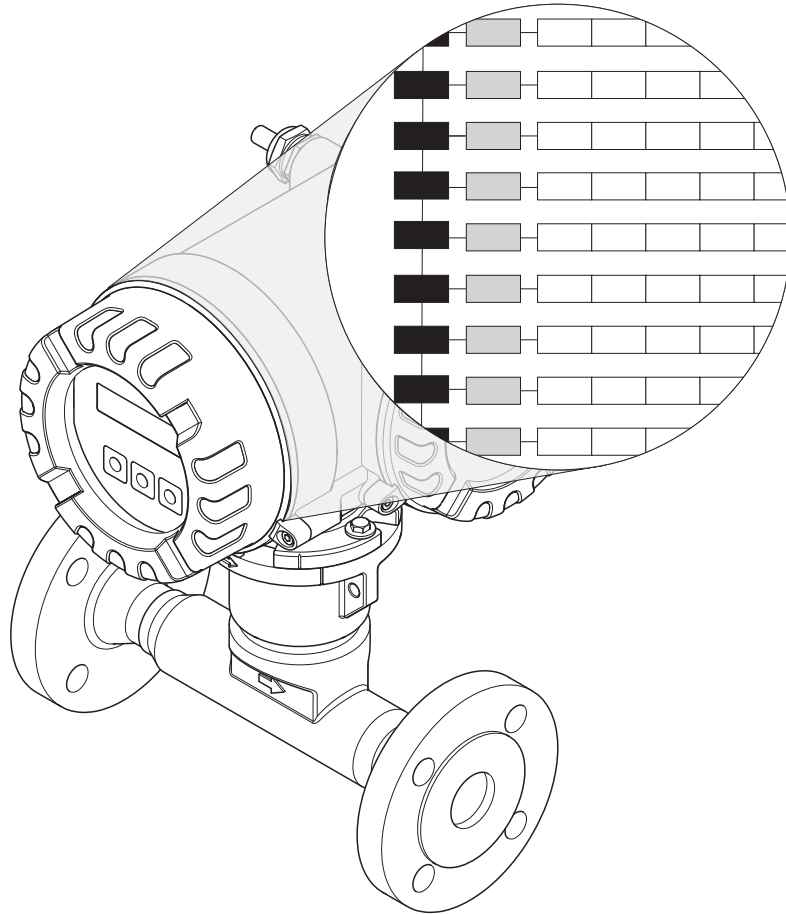

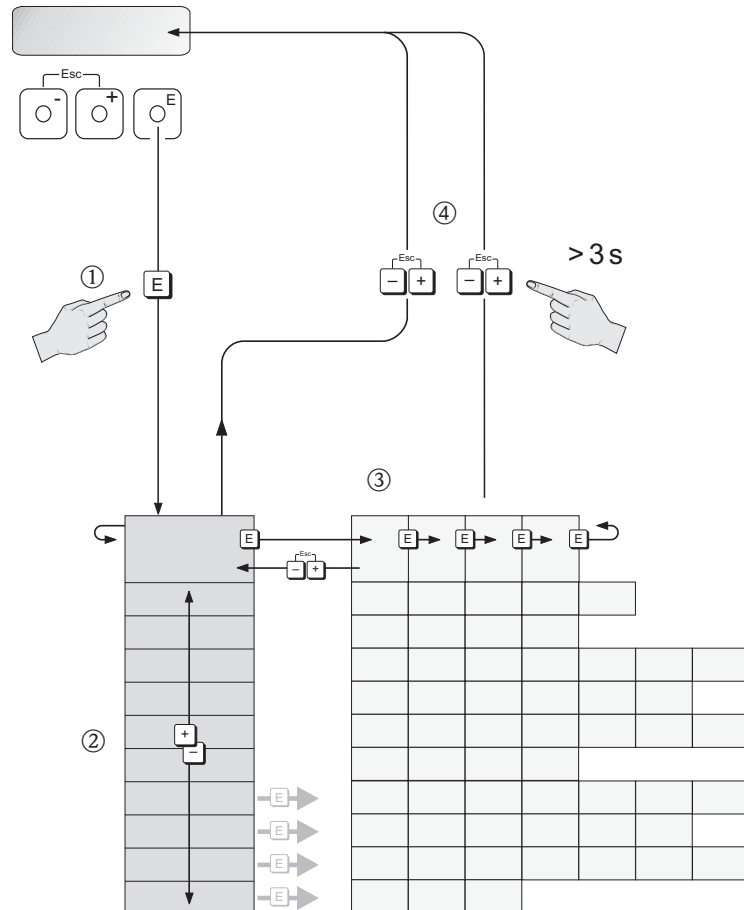

Table of contents

1	The function matrix: layout and use . . .	4	6	OPERATION	24
2	Illustration of the function matrix. . . .	5	7	USER INTERFACE	26
3	MEASURING VALUES	7	8	TOTALIZER 1/2	29
4	SYSTEM UNITS	8	9	HANDLING TOTALIZER	31
5	QUICK SETUP	12	10	STATUS INPUT	32
5.1	Quick Setup "Commissioning"	14	11	COMMUNICATION	34
5.2	Quick Setup "Communication"	16	12	PROCESS PARAMETER.	37
5.3	Quick Setup "Sensor"	17	13	GAS	41
5.4	"Gas" Quick Setup menu	18	14	HEAT FLOW	46
5.5	"Pressure" Quick Setup menu	20	15	SYSTEM PARAMETER	48
5.6	"Heat Flow" Quick Setup menu	21	16	SENSOR DATA	49
5.7	Data backup/transmission	23	17	SUPERVISION	53
			18	SIMULATION SYSTEM	55
			19	SENSOR VERSION	56
			20	AMPLIFIER VERSION	57
			21	Factory settings.	58
			21.1	Language →  24	58
			21.2	SI units (not for USA and Canada)	58
			21.3	US units (only for USA and Canada)	60
				Index	62

1 The function matrix: layout and use

The function matrix is a two-level construction: the groups form one level and the groups' functions the other. The groups are the highest-level grouping of the control options for the measuring device. A number of functions is assigned to each group. You select a group in order to access the individual functions for operating and configuring the measuring device. You can find an overview of all the groups available in the table of contents on page 3 and in the graphic representation of the function matrix on page 6. On page 6 you can also find an overview of all the functions available with the page references to the specific function description. A description of the individual functions is provided on page 7 and onwards.



A0001142

2 Illustration of the function matrix

Groups/function groups		Functions			
MEASURING VALUES	→ 7	MASS FLOW	CORRECTED VOLUME FLOW	HEAT FLOW	TEMPERATURE
↓					
SYSTEM UNITS	→ 8	UNIT MASS FLOW	UNIT CORRECTED VOLUME FLOW	UNIT CALORIFIC VALUE MASS	UNIT CALORIFIC VALUE CORRECTED VOLUME
↓		UNIT HEAT FLOW	UNIT PRESSURE	UNIT TEMPERATURE	UNIT DENSITY
		UNIT LENGTH			
QUICK SETUP	→ 12	QUICK SETUP COMMISSIONING	QUICK SETUP COMMUNICATION	QUICK SETUP SENSOR	QUICK SETUP GAS
↓		QUICK SETUP PRESSURE	QUICK SETUP HEAT FLOW	T-DAT SAVE/LOAD	
OPERATION	→ 24	LANGUAGE	ACCESS CODE	DEFINE PRIVATE CODE	STATUS ACCESS
↓		ACCESS CODE COUNTER			
USER INTERFACE	→ 26	ASSIGN LINE 1	ASSIGN LINE 2	100% VALUE LINE 1	100% VALUE LINE 2
↓		FORMAT	DISPLAY DAMPING	CONTRAST LCD	BACKLIGHT
		TEST DISPLAY			
TOTALIZER 1/2	→ 29	ASSIGN TOTALIZER	SUM	OVERFLOW	UNIT TOTALIZER
↓		RESET TOTALIZER			
HANDLING TOTALIZER	→ 31	RESET ALL TOTALIZERS	FAILSAFE MODE		
↓					
STATUS INPUT	→ 32	ASSIGN STATUS INPUT	ACTIVE LEVEL	MINIMUM PULSE WIDTH	ACTUAL STATUS INPUT
↓		SIMULATION STATUS INPUT	VALUE SIMULATION STATUS INPUT		
COMMUNICATION	→ 34	TAG NAME	FIELDBUS ADDRESS	BAUDRATE	TRANSMISSION MODE
↓		PARITY	BYTE ORDER	DELAY TELEGRAM REPLY	WRITE PROTECTION
		SCAN LIST REG. 1...16			
PROCESS PARAMETER	→ 37	PROCESS PRESSURE 1	PROCESS PRESSURE 2	PROCESS PRESSURE	REFERENCE PRESSURE
↓		REFERENCE TEMPERATURE	REFERENCE DENSITY	NET CALORIFIC VALUE	GROSS CALORIFIC VALUE
		MOLE % GAS 1	ASSIGN LOW FLOW CUT OFF	ON-VALUE LOW FLOW CUT OFF	OFF-VALUE LOW FLOW CUT OFF
		ZERO POINT ADJUST	INSTALLATION FACTOR		

Groups/function groups		Functions			
GAS ↓	→ 41	SELECT GROUP	NUMBER OF GASES	GAS TYPE 1	MOLE % GAS 1
		DESCRIPTION	CORRECTION FACTOR	REFERENCE DENSITY	GAS TYPE 2 to 8
		MOLE % GAS 2 to 8	CHECK VALUES	SAVE CHANGES	
HEAT FLOW ↓	→ 46	CALORIFIC VALUE TYPE	MODE 1	HEATING VALUE 1	MODE 2
		HEATING VALUE 2	REFERENCE COMBUSTION TEMPERATURE		
SYSTEM PARAMETER ↓	→ 48	POSITIVE ZERO RETURN	FLOW DAMPING		
SENSOR DATA ↓	→ 49	PIPE TYPE	PIPE STANDARD	NOMINAL DIAMETER	OUTER DIAMETER
		WALL THICKNESS	INTERNAL DIAMETER	INTERNAL HEIGHT	INTERNAL WIDTH
		MOUNTING	MOUNTING SET LENGTH	INSERTION DEPTH	ZERO POINT
		FLOW CONDITIONER			
SUPERVISION ↓	→ 53	ACTUAL SYSTEM CONDITION	PREVIOUS SYSTEM CONDITION	ALARM DELAY	SYSTEM RESET
		OPERATION HOURS	HOURS SINCE RESET		
SIMULATION SYSTEM ↓	→ 55	SIMULATION FAILSAFE MODE	SIMULATION MEASURAND	VALUE SIMULATION MEASURAND	
SENSOR VERSION ↓	→ 56	SENSOR TYPE	SERIAL NUMBER	TRANSDUCER SERIAL NUMBER	SOFTWARE REVISION NUMBER S-DAT
		PRE-AMPLIFIER SOFTWARE REVISION NUMBER	PRE-AMPLIFIER HARDWARE REVISION NUMBER		
AMPLIFIER VERSION ↓	→ 57	DEVICE SOFTWARE	HARDWARE REVISION NUMBER AMPLIFIER	SOFTWARE REVISION NUMBER AMPLIFIER	SOFTWARE REVISION NUMBER T-DAT
		I/O MODULE TYPE	SOFTWARE REVISION NUMBER I/O MODULE		

3 MEASURING VALUES

Function description, MEASURING VALUES group	
<p> Note! The engineering unit of the measured variable displayed here is configured in the SYSTEM UNITS group (→ 8)</p>	
<p>MASS FLOW</p> <p>Modbus register: 2007 Data type: Float Access: read</p>	<p>Description The currently measured mass flow appears on the display.</p> <p>Display: 5-digit floating-point number, including unit e.g. 462.87 kg/h; 731.63 lb/min</p>
<p>CORRECTED VOLUME FLOW</p> <p>Modbus register: 2011 Data type: Float Access: read</p>	<p>Description The calculated corrected volume flow appears on the display. The corrected volume flow is calculated from the measured mass flow and the reference density of the gas.</p> <p>Display: 5-digit floating-point number, including unit e.g. 104.97 Nm³/h; 110.73 Sm³/h; etc.</p>
<p>HEAT FLOW</p> <p>Modbus register: 2005 Data type: Float Access: read</p>	<p>Description The calculated heat flow appears on the display.</p> <p>Display: 5-digit floating-point number, including unit, (e.g. 175.00 kJ/h; 50.000 kBtu/h; etc.)</p>
<p>TEMPERATURE</p> <p>Modbus register: 2017 Data type: Float Access: read</p>	<p>Description The currently measured temperature appears on the display.</p> <p>Display: 5-digit fixed-point number, incl. unit and sign e.g. -23.4 °C, 160.0 °F, 295.4 K</p>

4 SYSTEM UNITS





Function description, SYSTEM UNITS group	
<p>UNIT MASS FLOW</p> <p>Modbus register 2101 Data type: Integer Access: read/write</p>	<p>Description For selecting the unit required and displayed for the mass flow. The unit you select here is also valid for:</p> <ul style="list-style-type: none"> ▪ Low flow cut off <p>The following time units can be selected: s = second, m = minute, h = hour, d = day</p> <p>Options</p> <p>SI: 0...3 = Gram → g/time unit 4...7 = Kilogram → kg/time unit 8...11 = Ton → t/time unit</p> <p>US: 12...15 = Ounce → oz/time unit 16...19 = Pound → lb/time unit 20...23 = Ton → ton/time unit</p> <p>Factory setting kg/h or lb/h (country dependent → 58)</p>
<p>UNIT CORRECTED VOLUME FLOW</p> <p>Modbus register 2105 Data type: Integer Access: read/write</p>	<p>Description For selecting the unit required and displayed for the corrected volume flow. The unit you select here is also valid for:</p> <ul style="list-style-type: none"> ▪ Low flow cut off <p>The following time units can be selected: s = second, m = minute, h = hour, d = day</p> <p>Options</p> <p>SI: 0...3 = Norm cubic meter → Nm³/time unit 4...7 = Norm liter → NI/time unit</p> <p>US: 8...11 = Standard cubic meter → Sm³/time unit 12...15 = Standard cubic feet → Sft³/time unit</p> <p>Factory setting Nm³/h or Sm³/h (country dependent → 58)</p>

Function description, SYSTEM UNITS group	
<p>UNIT CALORIFIC VALUE MASS</p> <p>Modbus register 2153 Data type: Integer Access: read/write</p>	<p>Description For selecting the unit required and displayed for the gross/net calorific value.</p> <p>Options (SI units) 0 = kJ/kg 1 = MJ/kg 2 = kWh/kg 3 = MWh/kg 4 = kcal/kg 5 = Mcal/kg</p> <p>Options (US units) 6 = Btu/lb 7 = kBtu/lb</p> <p>Factory setting MJ/kg or kBtu/lb (country dependent → 58)</p>
<p>UNIT CALORIFIC VALUE CORRECTED VOLUME</p> <p>Modbus register 2156 Data type: Integer Access: read/write</p>	<p>Description For selecting the unit required and displayed for the calorific value based on the corrected volume.</p> <p>Options (SI units): 0 = kJ/Nm³ 1 = MJ/Nm³ 2 = kWh/Nm³ 3 = MWh/Nm³ 4 = kcal/Nm³ 5 = Mcal/Nm³</p> <p>Options (US units): 6 = Btu/Sft³ 7 = kBtu/Sft³</p> <p>Factory setting MJ/Nm³ or kBtu/Sft³ (country dependent → 58)</p>

Function description, SYSTEM UNITS group	
<p>UNIT HEAT FLOW</p> <p>Modbus register: 2132 Data type: Integer Access: read/write</p>	<p>Description For selecting the unit required and displayed for the heat flow.</p> <p>The following time units can be selected: s = second, m = minute, h = hour, d = day</p> <p>Options (SI unit) 0 = kW 1 = MW 2...5 = kJ/time unit 6...9 = MJ/time unit 10...13 = GJ/time unit 14...19 = kcal/time unit 18...21 = Mcal/time unit 22...25 = Gcal/time unit</p> <p>Options (US unit) 26 = tons 27...30 = kBtu/time unit 31...34 = MBtu/time unit 35...38 = GBtu/time unit</p> <p>Factory setting kW or kBtu/h (country dependent → 58)</p>
<p>UNIT PRESSURE</p> <p>Modbus register: 2130 Data type: Integer Access: read/write</p>	<p>Description Use this function to select the unit for pressure.</p> <p>The unit you select here is also valid for:</p> <ul style="list-style-type: none"> ▪ Process pressure (see PROCESS PARAMETER group, → 37) ▪ Reference pressure (see PROCESS PARAMETER group, → 37) <p>Options 0 = bar a (bar absolute) 1 = psi a (pound per square inch absolute) 4 = kPa a (Kilopascal absolute)</p> <p>Factory setting bar a or psi a (country dependent → 58)</p>
<p>UNIT TEMPERATURE</p> <p>Modbus register: 2009 Data type: Integer Access: read/write</p>	<p>Description For selecting the unit required and displayed for the temperature.</p> <p>Options 0 = °C (CELSIUS) 1 = K (KELVIN) 2 = °F (FAHRENHEIT) 3 = R (RANKINE)</p> <p>Factory setting °C or °F (country dependent → 58)</p>
<p>UNIT DENSITY</p> <p>Modbus register: 2107 Data type: Integer Access: read/write</p>	<p>Description For selecting the unit required and displayed for the calculated gas density at process conditions. The unit you select here is also valid for:</p> <ul style="list-style-type: none"> ▪ Reference density (see PROCESS PARAMETER group, → 37) <p>Options SI: 0...1 = g/cm³; g/cc 2...4 = kg/dm³; kg/l; kg/m³ US: 11 = lb/ft³</p> <p>Factory setting kg/m³ or lb/ft³ (country dependent → 58)</p>

Function description, SYSTEM UNITS group	
<p>UNIT LENGTH</p> <p>Modbus register 2125 Data type: Integer Access: read/write</p>	<p>Prerequisite This function is only available for the insertion sensor (t-mass 65I)</p> <p>Description For selecting the unit of length required and displayed for the pipe internal diameter or the inner dimensions of rectangular ducts (see SENSOR DATA function group → 49).</p> <p>Options 0 = MILLIMETER 1 = INCH</p> <p>Factory setting MILLIMETER or INCH (country dependent → 58)</p>

5 QUICK SETUP

Function description, QUICK SETUP group	
QUICK SETUP COMMISSIONING	<p>Description Starts the Quick Setup menu for commissioning. For a flowchart of the QUICK SETUP COMMISSIONING: →  14.</p> <p>Options 0 = NO 1 = YES</p> <p>Factory setting NO</p>
QUICK SETUP COMMUNICATION	<p>Description Use this function to start the setup menu for the settings of the PRO-FIBUS DP communication parameters. For a flowchart of the QUICK SETUP COMMUNICATION: →  16.</p> <p>Options 0 = NO 1 = YES</p> <p>Factory setting NO</p>
QUICK SETUP SENSOR	<p>Prerequisite This function is only available for insertion sensors (t-mass 65I).</p> <p>Description Use this function to start the application-specific setup to calculate the insertion depth for the insertion sensor. For a flowchart of the QUICK SETUP SENSOR: →  17.</p> <p>Options 0 = NO 1 = YES</p> <p>Factory setting NO</p>
QUICK SETUP GAS	<p>Description Use this function to start the application-specific setup for programming the gas or gas mixture. For a flowchart of the QUICK SETUP GAS: →  18.</p> <p>Options 0 = NO 1 = YES</p> <p>Factory setting NO</p>

Function description, QUICK SETUP group	
<p>QUICK SETUP PRESSURE</p>	<p>Description Use this function to start the application-specific setup for programming the process pressure for each gas group. For a flowchart of the QUICK SETUP PRESSURE: → 20.</p> <p>Options 0 = NO 1 = YES</p> <p>Factory setting NO</p>
<p>QUICK SETUP HEAT FLOW</p>	<p>Description Use this function to start the application-specific setup for heat flow. For a flowchart of the QUICK SETUP HEAT FLOW: → 21.</p> <p>Options 0 = NO 1 = YES</p> <p>Factory setting NO</p>
<p>T-DAT SAVE/LOAD</p> <p>Modbus register 2401 Data type: Integer Access: read/write</p>	<p>Description Use this function to save the configuration/settings of the transmitter to a transmitter-DAT (T-DAT), or to load a configuration from the T-DAT to the EEPROM (manual backup function). For a flowchart of the T-DAT SAVE/LOAD: → 23.</p> <p>Application examples:</p> <ul style="list-style-type: none"> ▪ After commissioning, the current measuring point parameters can be saved to the T-DAT as a backup. ▪ If the transmitter is replaced for some reason, the data from the T-DAT can be loaded into the new transmitter (EEPROM). <p>Options 0 = CANCEL 1 = SAVE (from the EEPROM to the T-DAT) 2 = LOAD (from the T-DAT to the EEPROM)</p> <p> Note!</p> <ul style="list-style-type: none"> ▪ If the target device has an older software version, the message "TRANSM. SW-DAT" is displayed during startup. Then only the "SAVE" option is available. ▪ LOAD This option is only possible: <ul style="list-style-type: none"> – if the target device has the same software version as, or a more recent software version than, the source device or – if the T-DAT contains valid data that can be called up ▪ SAVE This function is always available. <p>Factory setting CANCEL</p>

5.1 Quick Setup "Commissioning"

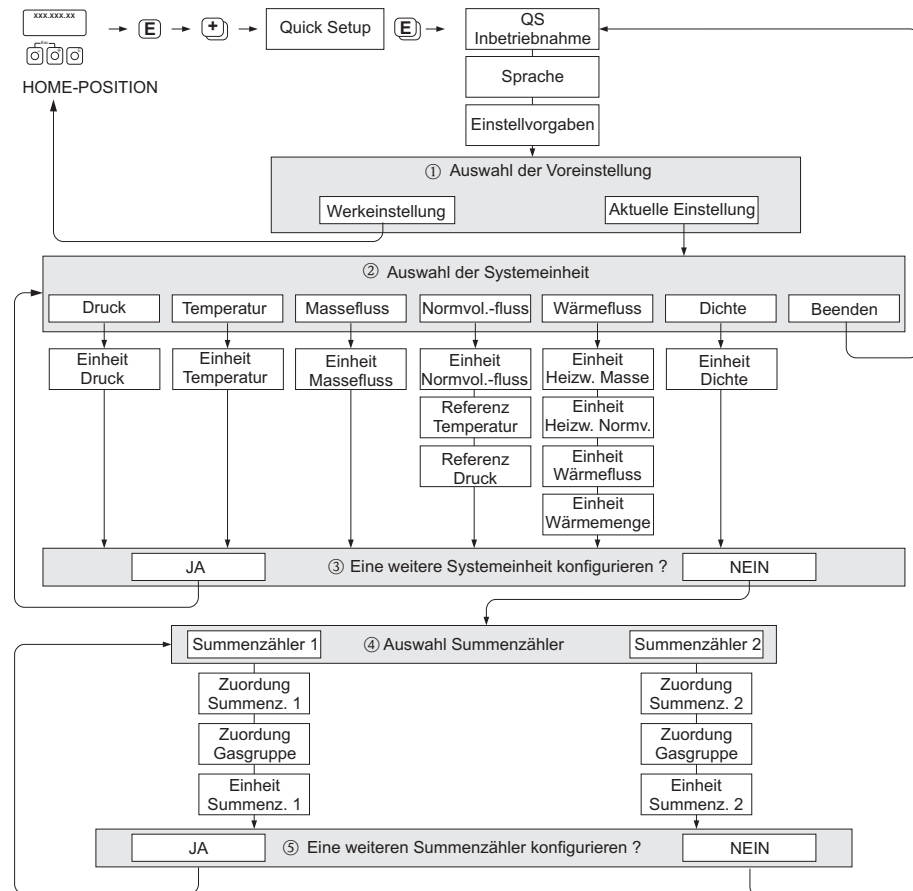

A0005510-en







Fig. 1: QUICK SETUP COMMISSIONING- menu for straightforward configuration of the major device functions





Note!

The display returns to the QUICK SETUP cell if you press the ESC key combination () during programming of a parameter anywhere in the menu. The configuration settings already made remain valid, however.

QUICK SETUP - COMMISSION

Use the  or  key at the prompt "QS-COMMISSION NO" and the device access code entry appears. Enter the device access code "65" and press ; programming is enabled. The prompt "QS-COMMISSION NO" appears. Use the  or  key to change NO to YES and press .

LANGUAGE

Use the  or  key to select the required language and continue with .

PRE-SETTING

① Select ACTUAL SETTINGS to continue programming the device and go to the next level or select DELIVERY SETTINGS to reset the device. The device restarts and returns to the Home position.

- ACTUAL SETTINGS are the actual programmed parameters in the device

- DELIVERY SETTINGS are the programmed parameters (factory settings plus customer specific settings) originally delivered with the device

SYSTEM UNITS

Select required system unit function and carry out parameterization or select QUIT to return to the QUICK SETUP function if no further programming is required.

- ② Only units not yet configured in the current setup are available for selection in each cycle.
- ③ The YES option remains visible until all the units have been configured.
NO is the only option displayed when no further units are available.

SELECTION TOTALIZER

- ④ Select a totalizer and assign a flow variable, gas group and unit.
- ⑤ Select a second totalizer or select "NO" to exit.

5.2 Quick Setup "Communication"

To establish serial data transfer, various arrangements between the Modbus master and Modbus slave are required which have to be taken into consideration when configuring various functions. These functions can be configured quickly and easily by means of the Communication Quick Setup. The configuration options for the parameters are explained in detail in the table that follows.

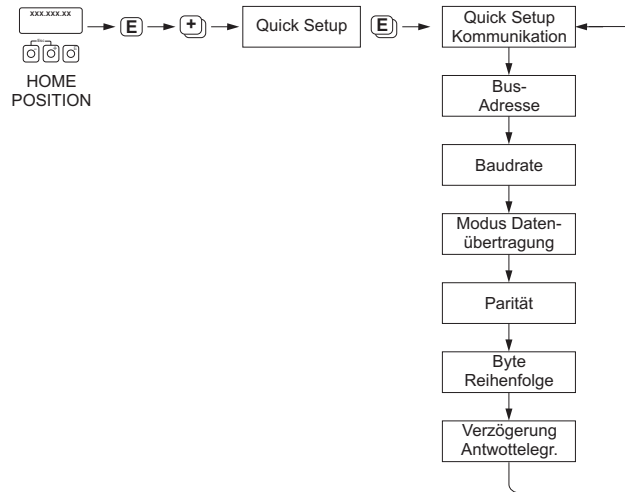

A0005503-en

Fig. 2: Quick Setup Communication

Settings for the Communication Setup menu:		
Function name	Suggested settings	Description
Call up through the function matrix:		
QUICK SETUP	QUICK SETUP COMMUNICATION	→ 12
QUICK SETUP COMMUNICATION	YES	→ 12
Basic configuration:		Factory setting:
FIELDBUS ADDRESS	247	→ 34
BAUDRATE	19200 BAUD	→ 34
TRANSMISSION MODE	RTU	→ 34
PARITY	EVEN	→ 35
BYTE ORDER	1 - 0 - 3 - 2	→ 35
DELAY TELEGRAM REPLY	10 ms	→ 35

5.3 Quick Setup "Sensor"

It is essential that the insertion sensor is setup according to the actual pipe or duct and then installed at the calculated insertion depth. This Quick Setup guides you systematically through the procedure to setup the sensor.



Note!

The QUICK SETUP SENSOR function is not available for flanged type sensors.

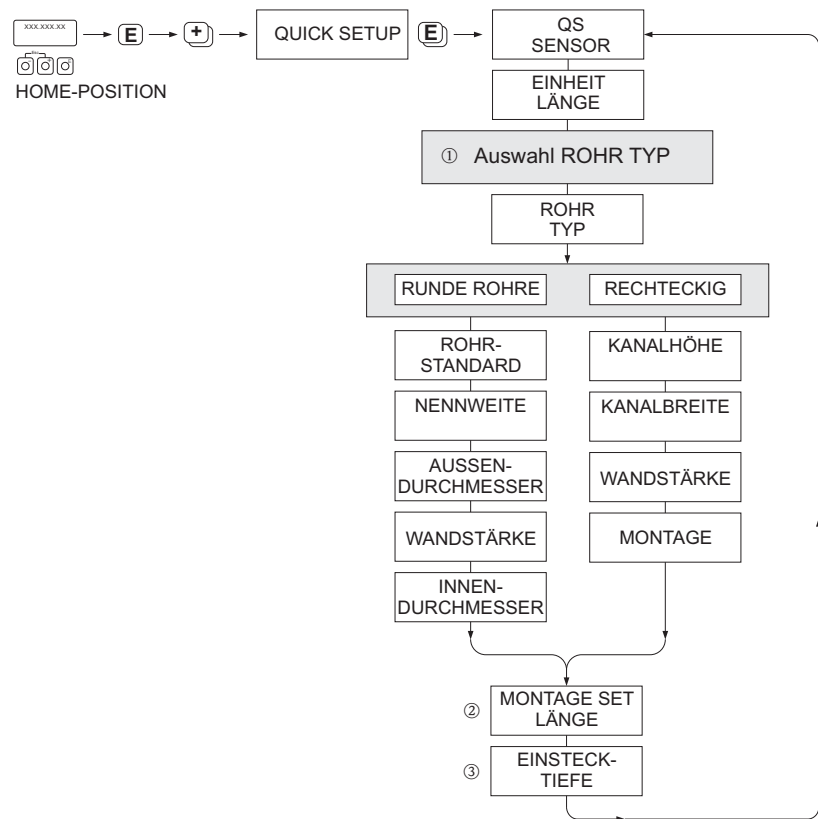

A0009910-en

PIPE TYPE

① ■ CIRCULAR

- in case that the pipe is of a standard type, then parameterize functions PIPE STANDARD and NOMINAL DIAMETER
- In case that the pipe is a non-standard type, then select OTHERS in the function PIPE STANDARD and parameterize the functions WALL THICKNESS and OUTER DIAMETER.
- The function INTERNAL DIAMETER displays the calculated internal diameter and is read only.

■ RECTANGULAR

- Enter the INTERNAL HEIGHT, INTERNAL WIDTH and WALL THICKNESS of the duct
- Select the MOUNTING orientation of the sensor: HORIZONTAL or VERTICAL

MOUNTING SET LENGTH

- ② Enter the measured length of the mounting set (including the compression fitting).

INSERTION DEPTH

- ③ This function calculates the insertion depth value for the mounting of the sensor. This function is read only.

Press **E** to save settings and return to QUICK SETUP SENSOR group.

5.4 "Gas" Quick Setup menu

The device can be setup with 1 or 2 individual gas groups in memory. This means that up to 2 different gas flow streams (e.g. nitrogen and argon) can be measured in a single pipe with one flowmeter.

In the case of 2 gas groups being used, a digital input can be assigned to switch between the gas groups or, alternatively, the switch can be done manually via a function in the device software. Furthermore, a programmed gas mixture can be dynamically updated, via a signal from a gas analyzer.

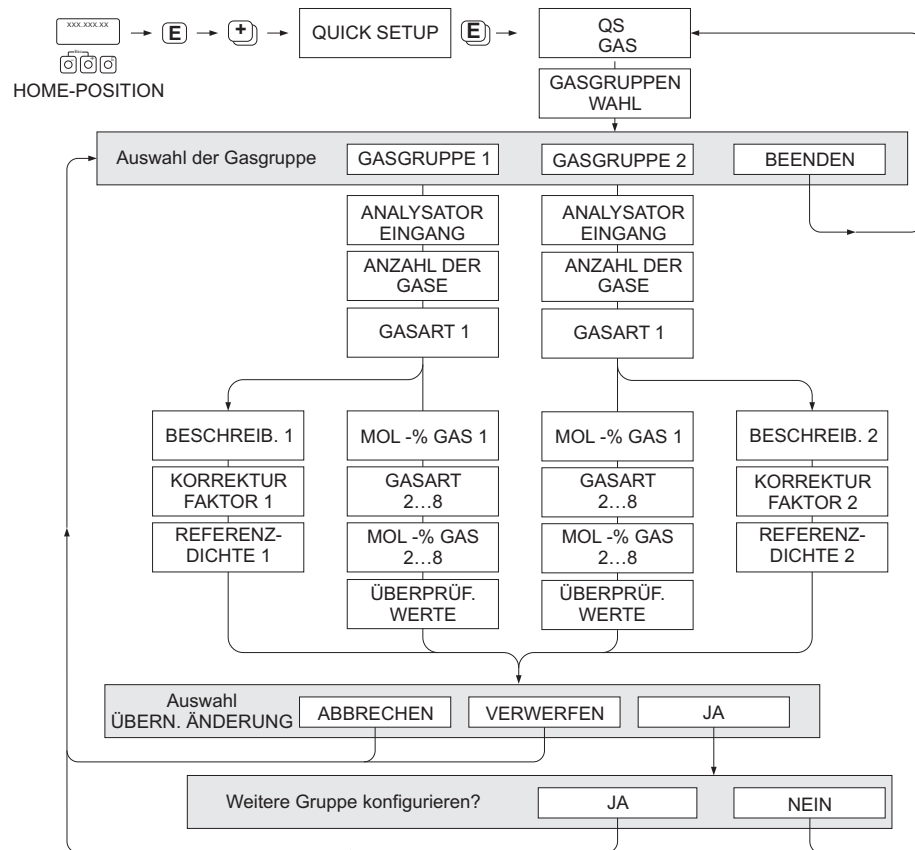

A0009907-en

Programming a gas group

The device allows flexible change of the gas group parameters, independent of the original factory setup and calibration



A gas group can be programmed as:

- one single gas or
- one gas mixture (of up to 8 components)

A single gas can be:

- selected from a list of standard gases or
- setup for other suitable types of gases, such as Ozone, using manual correction factors and the option called SPECIAL GAS. This requires application evaluation at the factory - consult your Endress+Hauser sales center prior to using this function.

Setting or viewing the active gas group

Go to the function **SELECT GROUP** (→  42) and simply select 1 or 2 and then exit using ESC ( keys simultaneously). No save function is necessary.





Note!

This Quick Setup Gas function is not available if an in-situ calibration function has been performed on the device as the in-situ calibration curve refers to the sensor power at each recorded flow point. Therefore, the programmed gas settings become redundant.

Performing the Quick Setup



1. GAS GROUP

- Use the  or  key to select the required GAS GROUP and continue with .
- Set the ANALYZER INPUT to ON if a gas compensation input is being used
- Select the NUMBER OF GASES in the group from 1 to 8.
- Select the GAS TYPE from the choose list.
- Enter the MOLE % for each GAS TYPE (only if NUMBER OF GASES is 2 and more).
- The error message CHECK VALUES appears if the total mixture % does not equal 100%. Go back and check the mixture settings.

2. SAVE CHANGES?

- Select YES to save the settings in GAS GROUP 1 or 2 and activate the last gas group selected. Press  to continue or
- Select CANCEL to save the entered settings in buffer memory but not activate them for measurement. If this function is selected, then it will be necessary to come back to this gas group and save it at a later stage.
- Select DISCARD to clear the last changes and return to CONFIGURE GROUP to make new settings.

3. ANOTHER GAS GROUP?

- Select YES to continue to the CONFIGURE GROUP function. Use the  or  key to select the desired GAS GROUP and proceed as per the above instructions.
- Select NO to exit to the Quick Setup.



Note!

You can find more detailed information on the GAS GROUP in chapter GAS →  41

5.5 "Pressure" Quick Setup menu

Use this Quick Setup to program the individual process pressure for each gas group. If only one gas group is being used, then only the function PROCESS PRESSURE 1 needs to be programmed, PROCESS PRESSURE 2 can remain with default settings.

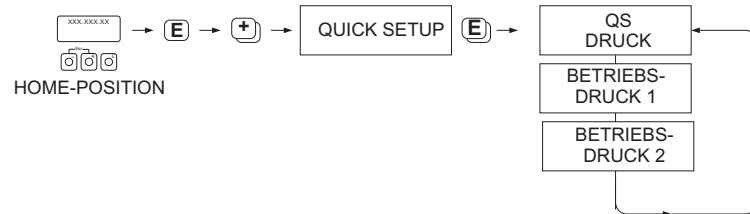

A0009908-en



Note!

- The device operates with absolute pressure only. Convert any gauge pressures to absolute pressure.
- If a pressure compensating input is being used, then the input signal value overrides the manually programmed value. The pressure input value applies to both gas groups. i.e. 2 independent pressure values are no longer possible.
- This Quick Setup Gas function is not available if an in-situ calibration function has been performed on the device as the in-situ calibration curve refers to the sensor power at each recorded flow point. Therefore, the programmed pressure settings become redundant.

5.6 "Heat Flow" Quick Setup menu

The device can calculate and output the heat of combustion of common fuel gases such as methane, natural gas, propane, butane, ethane and hydrogen. Use this Quick Setup menu to program the method used to calculate the heating value or calorific value (CV). The device can be configured to give two independent heating value outputs and totalized values. For example, the pipeline has either natural gas or propane running at separate times and the heating value is required for both gases.

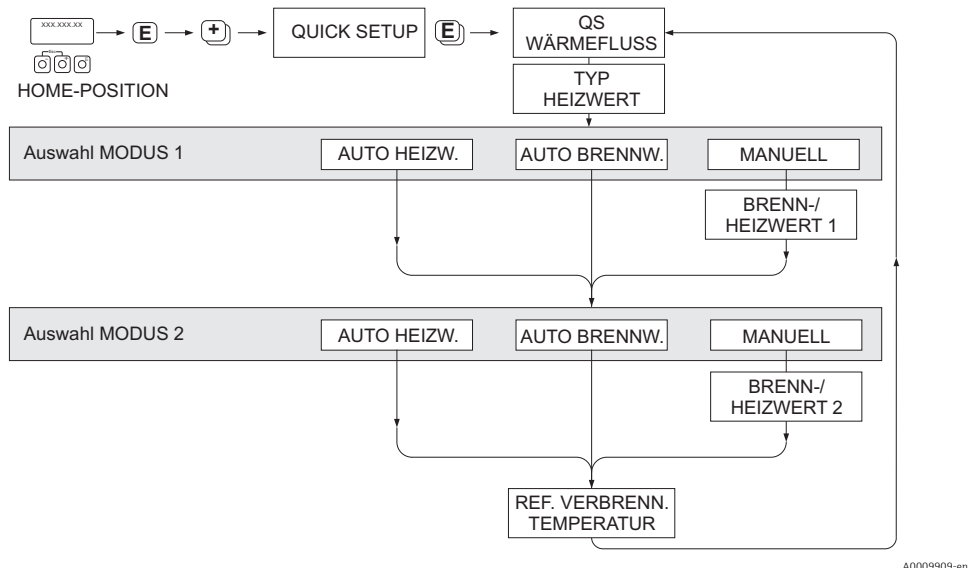

Calculation mode 1 and 2

- The heating value for CALCULATION MODE 1 corresponds to the settings in the function GAS GROUP 1.
- The heating value for CALCULATION MODE 2 corresponds to the settings in the function GAS GROUP 2.



Note!

- If only one gas group is used, then leave mode 2 as default settings.
- The units of measure are selected in the SYSTEM UNITS section → 8.

Auto Gross

The gross heating value (or higher heating value) is the total heat obtained by complete combustion at constant pressure of a volume of gas in air, including the heat released by the water vapor in the combustion products (gas, air and combustion products taken at reference combustion temperature and standard pressure).

Auto Net

The net heating value (or lower heating value) is determined by subtracting the heat of vaporization of the water vapor from the higher heating value. This treats any water formed as water vapor. The energy required to vaporize the water therefore is not realized as heat.

Manual

This function allows entry of a user-specific heating value if the required value is different from the value in the following table.

Gas	Formula	Net/lower heating value		Gross/upper heating value	
		[Mj/kg]	MBtu/lb	[Mj/kg]	MBtu/lb
Hydrogen	H ₂	119.91	51.56	141.78	60.97
Ammonia	NH ₃	18.59	7.99	22.48	9.67
Carbon Monoxide	CO	10.1	4.34	10.1	4.34
Hydrogen Sulphide	H ₂ S	15.2	6.54	19.49	8.38
Methane	CH ₄	50.02	21.51	55.52	23.87
Ethane	C ₂ H ₆	47.5	20.43	51.93	22.33
Propane	C ₃ H ₈	46.32	19.92	50.32	21.64
Butane	C ₄ H ₁₀	45.71	19.66	49.51	21.29
Ethylene	C ₂ H ₄	47.16	20.28	50.31	21.63

* According to ISO 6976:1995(E) and GPA Standard 2172-96

reference combustion temperature

The following reference temperatures are used:

Country	reference combustion temperature
Austria, Belgium, Denmark, Germany, Italy, Luxembourg, The Netherlands, Poland, Russia, Sweden, Switzerland	25 °C
Brazil, China	20 °C
France, Japan	0 °C
Australia, Canada, Czech Republic, Hungary, India, Ireland, Malaysia, Mexico, South Africa, Great Britain	15 °C
Slovakia	25 °C
USA, Venezuela	60 °F

5.7 Data backup/transmission

Using the T-DAT SAVE/LOAD function, you can transfer data (device parameters and settings) between the T-DAT (exchangeable memory) and the EEPROM (device storage unit).

This is required in the following instances:

- Creating a backup: current data are transferred from an EEPROM to the T-DAT.
- Replacing a transmitter: current data are copied from an EEPROM to the T-DAT and then transferred to the EEPROM of the new transmitter.
- Duplicating data: current data are copied from an EEPROM to the T-DAT and then transferred to EEPROMs of identical measuring points.



Note!

For information on installing and removing the T-DAT see Operating Instructions BA00115D/06

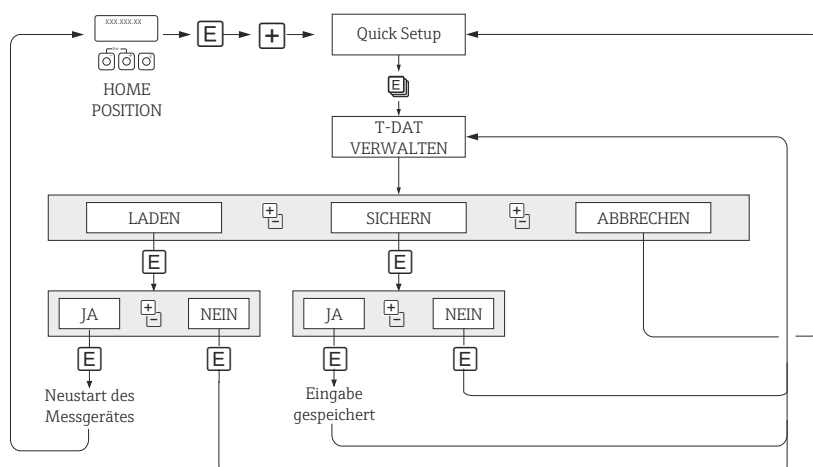

Fig. 3: Data backup/transmission with T-DAT SAVE/LOAD function

A0001221-en

Information on the LOAD and SAVE options available

LOAD

Data are transferred from the T-DAT to the EEPROM.







Note!

- Any settings already saved on the EEPROM are deleted.
- This option is only available, if the T-DAT contains valid data.
- This option can only be executed if the software version of the T-DAT is the same or newer than that of the EEPROM. Otherwise, the error message "TRANSM. SW-DAT" appears after restarting and the LOAD function is then no longer available.

SAVE

Data are transferred from the EEPROM to the T-DAT

6 OPERATION

Function description, OPERATION group	
<p>LANGUAGE</p> <p>Modbus register 2502 Data type: Integer Access: read/write</p>	<p>Description For selecting the language in which all messages are shown on the local display. If you press the  keys simultaneously at startup, the language defaults to "ENGLISH".</p> <p>Options 0 = ENGLISH 1 = DEUTSCH 2 = FRANCAIS 3 = ESPANOL 4 = ITALIANO 5 = NEDERLANDS 6 = NORSK 7 = SVENSKA 8 = SUOMI 9 = PORTUGUES 10 = POLSKI 11 = CESKI</p> <p>Factory setting country dependent →  58</p>
<p>ACCESS CODE</p> <p>Modbus register 2508 Data type: Float Access: read/write</p>	<p>Description All data of the measuring device are protected against inadvertent change. Programming is disabled and the settings cannot be changed until a code is entered. If you press the  operating elements in any function, the measuring device automatically goes to this function and the prompt to enter the code appears on the display (programming disabled). You can enable programming by entering the private code (factory setting = 65, see DEFINE PRIVATE CODE function (→  24)).</p> <ul style="list-style-type: none"> ▪ The programming levels are disabled if you do not press the operating elements within 60 seconds following a return to the HOME position. ▪ Programming can also be disabled by entering any number (other than the private code). ▪ Your Endress+Hauser sales center can be of assistance if you mislay your private code. <p> Note! This function is only relevant for the local display and does not affect data transmission via the Modbus communication.</p> <p>User input Max. 4-digit number: 0 to 9999</p>
<p>DEFINE PRIVATE CODE</p> <p>Modbus register 2510 Data type: Float Access: read/write</p>	<p>Description Use this function to specify the private code for enabling programming.</p> <ul style="list-style-type: none"> ▪ Programming is always enabled if the code defined = 0. ▪ Programming has to be enabled before the code can be changed. When programming is disabled this function cannot be edited, thus preventing others from accessing your personal code. <p>User input Max. 4-digit number: 0 to 9999</p> <p>Factory setting 65</p>

Function description, OPERATION group	
<p>STATUS ACCESS</p> <p>Modbus register 2512 Data type: Integer Access: read/write</p>	<p>Description The access status for this function matrix appears on the display.</p> <p>Display: 0 = LOCKED (parameters cannot be modified) 1 = ACCESS CUSTOMER (parameters can be modified)</p>
<p>ACCESS CODE COUNTER</p> <p>Modbus register 2568 Data type: Float Access: read/write</p>	<p>Description The number of times the private and service code was entered to access the device appears on the display.</p> <p>Display: Integer</p> <p>Factory setting 0</p>

7 USER INTERFACE

Function description, USER INTERFACE group	
<p>ASSIGN LINE 1</p> <p>Modbus register: 2514 Data type: Integer Access: read/write</p>	<p>Description For assigning a display value to the main line (top line of the local display). This value is displayed during normal operation.</p> <p>Options 0 = OFF 1 = MASS FLOW 2 = MASS FLOW IN % 3 = TEMPERATURE 4 = TOTALIZER 1 5 = TOTALIZER 2 13 = CORRECTED VOLUME FLOW 14 = CORRECTED VOLUME FLOW IN % 16 = HEAT FLOW 17 = HEAT FLOW IN %</p> <p>Factory setting MASS FLOW</p>
<p>ASSIGN LINE 2</p> <p>Modbus register: 2515 Data type: Integer Access: read/write</p>	<p>Description For assigning a display value to the additional line (bottom line of the local display). This value is displayed during normal operation.</p> <p>Options 0 = OFF 1 = MASS FLOW 2 = MASS FLOW IN % 3 = MASS FLOW BARGRAPH IN % 4 = TEMPERATURE 5 = TOTALIZER 1 6 = TOTALIZER 2 9 = TAG NAME 10 = OPERATING/SYSTEM CONDITIONS 11 = CORRECTED VOLUME FLOW 12 = CORRECTED VOLUME FLOW IN % 13 = CORRECTED VOLUME FLOW BARGRAPH IN % 20 = HEAT FLOW 21 = HEAT FLOW IN % 22 = HEAT FLOW BARGRAPH IN %</p> <p>Factory setting TOTALIZER 1</p>
<p>100% VALUE LINE 1</p> <p>Modbus register: 2519 Data type: Float Access: read/write</p>	<p>Prerequisite This function is only available if one of the following options was selected in the ASSIGN LINE 1 function (→ 26):</p> <ul style="list-style-type: none"> ■ MASS FLOW IN % ■ CORRECTED VOLUME FLOW IN % ■ HEAT FLOW IN % <p>Description Use this function to enter the flow value which should be shown on the display as the 100% value.</p> <p>User input 5-digit floating-point number</p> <p>Factory setting 10 kg/h (with mass flow) 10 Nm³/h (with corrected volume flow) 10 kW (with heat flow)</p>

Function description, USER INTERFACE group	
<p>100% VALUE LINE 2</p> <p>Modbus register: 2564 Data type: Float Access: read/write</p>	<p>Prerequisite This function is only available if one of the following options was selected in the ASSIGN LINE 2 function (→ 26):</p> <ul style="list-style-type: none"> ■ MASS FLOW IN % ■ CORRECTED VOLUME FLOW IN % ■ HEAT FLOW IN % ■ MASS FLOW BARGRAPH IN % ■ CORRECTED VOLUME FLOW BARGRAPH IN % ■ HEAT FLOW BARGRAPH IN % <p>Description Use this function to enter the flow value which should be shown on the display as the 100% value.</p> <p>User input 5-digit floating-point number</p> <p>Factory setting 10 kg/h (with mass flow) 10 Nm³/h (with corrected volume flow) 10 kW (with heat flow)</p>
<p>FORMAT</p> <p>Modbus register: 2516 Data type: Integer Access: read/write</p>	<p>Description For selecting the number of decimal places for the display value in the main line.</p> <ul style="list-style-type: none"> ■ Note that this setting only affects the reading as it appears on the display, it has no influence on the accuracy of the system's calculations. ■ The places after the decimal point as computed by the measuring device cannot always be displayed, depending on this setting and the engineering unit. In these instances an arrow appears on the display between the measured value and the engineering unit (e.g. 1.2 → kg/h), indicating that the measuring device is computing with more decimal places than can be shown on the display. <p>Options 0 = XXXXX. 1 = XXXX.X 2 = XXX.XX 3 = XX.XXX 4 = X.XXXX</p> <p>Factory setting XX.XXX</p>
<p>DISPLAY DAMPING</p> <p>Modbus register: 2503 Data type: Float Access: read/write</p>	<p>Description For entering a time constant defining how the display reacts to severely fluctuating flow variables, either very quickly (enter a low time constant) or with damping (enter a high time constant). The setting 0 seconds switches off damping.</p> <p>User input 0 to 100 seconds</p> <p>Factory setting 3 seconds</p>
<p>CONTRAST LCD</p> <p>Modbus register: 2505 Data type: Float Access: read/write</p>	<p>Description For adjusting the display contrast to suit local operating conditions.</p> <p>User input 10 to 100%</p> <p>Factory setting 50%</p>

Function description, USER INTERFACE group	
<p>BACKLIGHT</p> <p>Modbus register 2566 Data type: Float Access: read/write</p>	<p>Description For adjusting the background lighting to suit local operating conditions. Entering the value "0" means that the backlight is "switched off". The display then no longer emits any light, i.e. the display texts can no longer be read in the dark.</p> <p>User input 0 to 100%</p> <p>Factory setting 50%</p>
<p>TEST DISPLAY</p> <p>Modbus register 2513 Data type: Integer Access: read/write</p>	<p>Description Use this function to test the operability of the local display and its pixels.</p> <p>Test sequence:</p> <ol style="list-style-type: none"> 1. Start the test by selecting ON. 2. All pixels of the main line and additional line are darkened for minimum 0.75 seconds. 3. The main line and additional line show an "8" in each field for minimum 0.75 seconds. 4. The main line and additional line show a "0" in each field for minimum 0.75 seconds. 5. The main line and additional line show nothing (blank display) for minimum 0.75 seconds. 6. When the test is completed, the local display returns to its initial state and displays the option OFF. <p>Options 0 = OFF 1 = ON</p> <p>Factory setting OFF</p>

8 TOTALIZER 1/2

Function description, TOTALIZER 1/2 group	
<p>ASSIGN TOTALIZER</p> <p>Modbus register: TOTALIZER 1 2601 TOTALIZER 2 2801 Data type: Integer Access: read/write</p>	<p>Description Use this function to assign a measured variable to the totalizer.</p> <ul style="list-style-type: none"> ■ The totalizer is reset to "0" as soon as the option selected is changed. ■ If you select OFF, only the ASSIGN TOTALIZER function is displayed in the Totalizer 1 or 2 group. <p>Options 0 = OFF 1 = MASS FLOW 2 = CORRECTED VOLUME FLOW 3 = HEAT FLOW</p> <p>Factory setting MASS FLOW</p>
<p>SUM</p> <p>Modbus register: TOTALIZER 1 2610 TOTALIZER 2 2810 Data type: Float Access: read</p>	<p>Description The total for the totalizers measured variable aggregated since measuring commenced appears on the display. The value is positive.</p> <p>The totalizers' response to errors is defined in the FAILSAFE MODE function (→ 31).</p> <p>Display: Max. 7-digit floating-point number, including unit (e.g. 15467.04 kg)</p>
<p>OVERFLOW</p> <p>Modbus register: TOTALIZER 1 2612 TOTALIZER 2 2812 Data type: Float Access: read</p>	<p>Description The total for the totalizers overflow aggregated since measuring commenced appears on the display.</p> <p>Total flow is represented by a floating-point number consisting of max. 7 digits. Higher numerical values (>9,999,999) can be viewed as overflows. The effective quantity is thus the total of the SUM function (→ 29) plus the value displayed in the OVERFLOW function.</p> <p>Example: Reading after 2 overflows: 2 E7 kg (= 20000000 kg) The value displayed in the SUM function = 196845.7 kg Effective total quantity = 20 196845.7 kg</p> <p>Display: Integer with exponent, including unit, e.g. 2 E7 kg</p>
<p>UNIT TOTALIZER</p> <p>Modbus register: TOTALIZER 1 2602 TOTALIZER 2 2804 Data type: Integer Access: read/write</p>	<p>Description For selecting the unit for the measured variable assigned to the totalizer.</p> <p>Options (ASSIGN TOTALIZER = MASS FLOW): SI → 0 = g; 1 = kg; 2 = t US → 3 = oz; 4 = lb; 5 = ton</p> <p>Factory setting kg or lb (country dependent → 58)</p> <p>Options (ASSIGN TOTALIZER = CORRECTED VOLUME FLOW): SI → 0 = NI, 1 = Nm³ US → 2 = Sm³, 3 = Sft³</p> <p>Factory setting Nm³ or Sm³ (country dependent → 58)</p> <p>Options (ASSIGN TOTALIZER = HEAT FLOW): SI → 0 = kWh, 1 = MWh, 2 = kJ, 3 = MJ, 4 = GJ, 5 = kcal, 6 = Mcal, 7 = Gcal US → 8 = kBtu, 9 = MBtu, 10 = GBtu, 11 = tonh</p> <p>Factory setting MWh or kBtu (country dependent → 58)</p>



Function description, TOTALIZER 1/2 group	
RESET TOTALIZER	Description Resets the sum and overflow in the totalizer selected.
Modbus register:	Options
TOTALIZER 1 2608	0 = NO
TOTALIZER 2 2808	1 = YES
Data type: Integer	Factory setting
Access: read/write	NO

9 HANDLING TOTALIZER

Function description, HANDLING TOTALIZER group	
<p>RESET ALL TOTALIZERS</p> <p>Modbus register 2609 Data type: Integer Access: read/write</p>	<p>Description Resets the sums and overflows of both totalizers to "zero" (=RESET). If the device is equipped with a status input and if it is appropriately configured, a totalizer reset (totalizers 1 and 2) can also be triggered by a pulse (see ASSIGN STATUS INPUT function on Page → 32).</p> <p>Options 0 = NO 1 = YES</p> <p>Factory setting NO</p>
<p>FAILSAFE MODE</p> <p>Modbus register 2607 Data type: Integer Access: read/write</p>	<p>Description For selecting the behavior of the totalizer in an alarm condition.</p> <p>Options 0 = STOP The totalizer does not continue to count the flow if a fault is present. The totalizer stops at the last value before the alarm condition occurred.</p> <p>1 = ACTUAL VALUE The totalizers continue to count on the basis of the current flow data. The fault is ignored.</p> <p>2 = HOLD VALUE The totalizer continues to count the flow on the basis of the last valid flow data (before the fault occurred).</p> <p>Factory setting STOP</p>

10 STATUS INPUT

Function description, STATUS INPUT group	
<p>ASSIGN STATUS INPUT</p> <p>Modbus register 4301 Data type: Integer Access: read/write</p>	<p>Description Use this function to assign a switching function to the status input.</p> <ul style="list-style-type: none"> ▪ Positive zero return is active as long as the level is present at the status input (continuous signal). All other assignments react to a change in level (pulse) at the status input. ▪ If you select OFF, the only function shown in this function group is the ASSIGN STATUS INPUT function. <p>Options 0 = OFF 1 = RESET TOTALIZER 1 2 = POSITIVE ZERO RETURN 3 = ZERO POINT ADJUST 4 = RESET TOTALIZER 2 5 = RESET ALL TOTALIZERS 6 = GAS GROUP</p> <p>Factory setting OFF</p>
<p>ACTIVE LEVEL</p> <p>Modbus register 4302 Data type: Integer Access: read/write</p>	<p>Description Use this function to define whether the assigned switching function (see ASSIGN STATUS INPUT function) is triggered or sustained when the signal level is present (HIGH) or not present (LOW).</p> <p>Options 0 = LOW 1 = HIGH</p> <p>Factory setting HIGH</p>
<p>MINIMUM PULSE WIDTH</p> <p>Modbus register 4303 Data type: Float Access: read/write</p>	<p>Description Use this function to specify the minimum pulse width which the input pulse has to reach in order to trigger the selected switching function (ASSIGN STATUS INPUT function).</p> <p>Options 20 to 100 ms</p> <p>Factory setting 50 ms</p>
<p>ACTUAL STATUS INPUT</p> <p>Modbus register 4305 Data type: Integer Access: read</p>	<p>Description Use this function to view the current level of the status input.</p> <p>Display 0 = LOW 1 = HIGH</p>

Function description, STATUS INPUT group	
<p>SIMULATION STATUS INPUT</p> <p>Modbus register: 4306 Data type: Integer Access: read/write</p>	<p>Description Use this function to simulate the status input, i.e. to trigger the function assigned to the status input (see ASSIGN STATUS INPUT function (→ 32)).</p> <ul style="list-style-type: none"> ■ Notice message #671 to 652 "SIM. STATUS INPUT" indicates that simulation is active. ■ The measuring device continues to measure while simulation is in progress i.e. the current measured values are output correctly via the other outputs. <p> Note! The setting is not saved if the power supply fails.</p> <p>Options 0 = OFF 1 = ON</p> <p>Factory setting OFF</p>
<p>VALUE SIMULATION STATUS INPUT</p> <p>Modbus register: 4307 Data type: Integer Access: read/write</p>	<p>Prerequisite This function is only available if ON was selected in the SIMULATION STATUS INPUT function (→ 33).</p> <p>Description Use this function to define the level to be assumed by the status input during simulation. This value is used to test downstream devices and the measuring device itself. When you exit This function and the SIMULATION STATUS INPUT function is activated (= ON), the message "END SIMULATION?" appears on the display. If you select YES, the simulation is terminated. If you select NO, the simulation is continued.</p> <p> Note! The setting is not saved if the power supply fails.</p> <p>Options 0 = LOW 1 = HIGH</p> <p>Factory setting LOW</p>

11 COMMUNICATION

Function description, COMMUNICATION group	
<p>TAG NAME</p> <p>Modbus register 4901 Data type: String Access: (16) read/write</p>	<p>Description Use this function to enter a tag name for the device. You can edit and read this tag name at the local display or via the Modbus communication.</p> <p>User input Max. 16-character text, permitted characters are: A-Z, 0-9, +, -, punctuation marks</p> <p>Factory setting "- - - - -" (no text)</p>
<p>FIELD BUS ADDRESS</p> <p>Modbus register 4910 Data type: Integer Access: read/write</p>	<p>Description For entering the device address.</p> <p>User input 1 to 247</p> <p>Factory setting 247</p>
<p>BAUDRATE</p> <p>Modbus register 4912 Data type: Integer Access: read/write</p>	<p>Description Use this function for selecting the baud rate.</p> <p>Options 0 = 1200 BAUD 1 = 2400 BAUD 2 = 4800 BAUD 3 = 9600 BAUD 4 = 19200 BAUD 5 = 38400 BAUD 6 = 57600 BAUD 7 = 115200 BAUD</p> <p>Factory setting 19200 BAUD</p>
<p>TRANSMISSION MODE</p> <p>Modbus register 4913 Data type: Integer Access: read/write</p>	<p>Description Use this function for selecting the data transfer mode.</p> <p>Options 0 = RTU Transmission of data in binary form. Error protection via CRC16.</p> <p>1 = ASCII Transmission of data in the form of readable ASCII characters. Error protection via LRC.</p> <p>Factory setting RTU</p>

Function description, COMMUNICATION group	
<p>PARITY</p> <p>Modbus register 4914 Data type: Integer Access: read/write</p>	<p>Description Use this function for selecting whether no parity bit or an even or odd parity bit should be transmitted.</p> <p>Options 0 = EVEN 1 = ODD 2 = NONE/STOP BITS 2 3 = NONE/STOP BITS 1</p> <p>Factory setting EVEN</p>
<p>BYTE ORDER</p> <p>Modbus register 4915 Data type: Integer Access: read/write</p>	<p>Prerequisite The transmission sequence must suit the Modbus master. More information can be found in Operating Instructions BA115D/06 under the keyword "Byte transmission sequence".</p> <p>Description Use this function to select the byte transmission sequence for the Integer, Float and String data types.</p> <p>Options 0 = 0-1-2-3 1 = 3-2-1-0 2 = 2-3-0-1 3 = 1-0-3-2</p> <p>Factory setting 1-0-3-2</p>
<p>DELAY TELEGRAM REPLY</p> <p>Modbus register 4916 Data type: Float Access: read/write</p>	<p>Description Use this function for entering a delay time after which the measuring device replies to the request telegram of the Modbus master. This allows communication to be adapted to slow Modbus masters.</p> <p>User input 0 to 100 ms</p> <p>Factory setting 10 ms</p>
<p>WRITE PROTECTION</p> <p>Modbus register 4918 Data type: Integer Access: read/write</p>	<p>Description Indicates whether write access to the device via local operation or Modbus is possible.</p> <p> Note! Write protection is activated and deactivated by means of a jumper on the I/O module (see Operating Instructions BA00115D/06)</p> <p>Display: 0 = OFF (write access via Modbus possible) 1 = ON (write access via Modbus blocked)</p> <p>Factory setting OFF</p>

Function description, COMMUNICATION group	
SCAN LIST REG. 1...16	Description
Modbus register	Use this function by entering the register address, up to 16 device parameters can be grouped in the auto-scan buffer where they are assigned to the scan list registers 1 to 16. The data of the device parameters assigned here are read out via the register addresses 5051 to 5081.
SCAN LIST REG.1: 5001	<p> Note! More detailed information and examples of using the auto-scan buffer are provided in Operating Instructions BA115D/06</p> <p>User input 0 to 9999</p> <p>Factory setting 0</p>
SCAN LIST REG.2: 5002	
SCAN LIST REG.3: 5003	
SCAN LIST REG.4: 5004	
SCAN LIST REG.5: 5005	
SCAN LIST REG.6: 5006	
SCAN LIST REG.7: 5007	
SCAN LIST REG.8: 5008	
SCAN LIST REG.9: 5009	
SCAN LIST REG.10: 5010	
SCAN LIST REG.11: 5011	
SCAN LIST REG.12: 5012	
SCAN LIST REG.13: 5013	
SCAN LIST REG.14: 5014	
SCAN LIST REG.15: 5015	
SCAN LIST REG.16: 5016	
Data type: Integer	
Access: read/write	



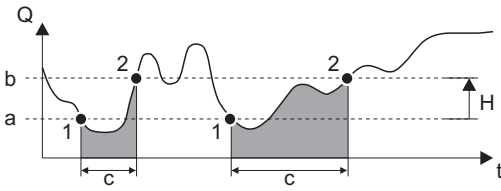

12 PROCESS PARAMETER

Function description, PROCESS PARAMETER group	
<p>PROCESS PRESSURE 1</p> <p>Modbus register 5268 Data type: Float Access: read/write</p>	<p>Prerequisite This function is not available if the IN-SITU CALIBRATION function has been enabled. Refer to your Endress+Hauser sales center for more information.</p> <p>Description Use this function to enter the process pressure for GAS GROUP 1. (Selection and composition by means of the functions in the GAS group). The unit is taken from the function UNIT PRESSURE (→ 10).</p> <p>Input/display 5-digit floating-point number</p> <p>Factory setting 1.0130 [bar a] or 14.692 [psi a] (country dependent → 58)</p>
<p>PROCESS PRESSURE 2</p> <p>Modbus register 5270 Data type: Float Access: read/write</p>	<p>Prerequisite This function is not available if the IN-SITU CALIBRATION function has been enabled. Refer to your Endress+Hauser sales center for more information.</p> <p>Description Use this function to enter the process pressure for GAS GROUP 2. (Selection and composition by means of the functions in the GAS group). The unit is taken from the function UNIT PRESSURE (→ 10).</p> <p>Input/display 5-digit floating-point number</p> <p>Factory setting 1.0130 [bar a] or 14.692 [psi a] (country dependent → 58)</p>
<p>PROCESS PRESSURE</p> <p>Modbus register 5185 Data type: Float Access: read/write</p>	<p>Description Use this function to display the pressure value which is used for the flow calculation. The value is read from the following function: PROCESS PRESSURE 1 or 2 (depending on which gas group is active)</p> <p>The unit is taken from the function UNIT PRESSURE (→ 10).</p> <p>Display 5-digit floating-point number</p> <p>Factory setting 1.0130 [bar a] or 14.692 [psi a] (country dependent → 58)</p>
<p>REFERENCE PRESSURE</p> <p>Modbus register 5217 Data type: Float Access: read/write</p>	<p>Description Use this function to enter the reference pressure for calculating the reference density (for corrected volume flow measurement). The unit is taken from the function UNIT PRESSURE (→ 10).</p> <p>User input 5-digit floating-point number</p> <p>Factory setting 1.0130 [bar a] or 14.692 [psi a] (country dependent → 58)</p>
<p>REFERENCE TEMPERATURE</p> <p>Modbus register 5136 Data type: Float Access: read/write</p>	<p>Description Use this function to enter the reference temperature for calculating the reference density (for corrected volume flow measurement). The unit is taken from the function UNIT TEMPERATURE (→ 10).</p> <p>User input 5-digit floating-point number</p> <p>Factory setting 0.0 [°C] or +32.0 [°F] (country dependent → 58.)</p>

Function description, PROCESS PARAMETER group	
<p>REFERENCE DENSITY</p> <p>Modbus register 5130 Data type: Float Access: read</p>	<p>Prerequisite This function is not available if the IN-SITU CALIBRATION function has been enabled. Refer to your Endress+Hauser sales center for more information.</p> <p>Description Use this function to display the calculated reference density (for corrected volume flow measurement). The unit is taken from the function UNIT DENSITY (→ 10).</p> <p>Display 5-digit floating-point number</p>
<p>NET CALORIFIC VALUE</p> <p>Modbus register 5272 Data type: Float Access: read</p>	<p>Prerequisite This function is only available if AUTO NET or MANUAL was selected in the MODE 1 or 2 function (→ 46).</p> <p>Description Use this function to display the current net calorific value of the gas. The unit is taken from the function UNIT CALORIFIC VALUE MASS (→ 9) or UNIT CALORIFIC VALUE CORRECTED VOLUME (→ 9).</p> <p>Display 5-digit floating-point number</p>
<p>GROSS CALORIFIC VALUE</p> <p>Modbus register 5274 Data type: Float Access: read</p>	<p>Prerequisite This function is only available if AUTO GROSS was selected in the MODE 1 or 2 function (→ 46).</p> <p>Description Use this function to display the current gross calorific value of the gas. The unit is taken from the function UNIT CALORIFIC VALUE MASS (→ 9) or UNIT CALORIFIC VALUE CORRECTED VOLUME (→ 9).</p> <p>Display 5-digit floating-point number</p>
<p>MOLE % GAS 1</p> <p>Modbus register 5276 Data type: Float Access: read</p>	<p>Description Use this function to display the Mole % of GAS TYPE 1. → 42</p> <p>Display 0.0 % to 100.0 %</p>
<p>ASSIGN LOW FLOW CUT OFF</p> <p>Modbus register 5101 Data type: Integer Access: read/write</p>	<p>Description For selecting the process variable on which low flow cut off should act.</p> <p>Options 0 = OFF 1 = MASS FLOW 2 = CORRECTED VOLUME FLOW</p> <p>Factory setting MASS FLOW</p>

Function description, PROCESS PARAMETER group	
<p>ON-VALUE LOW FLOW CUT OFF</p> <p>Modbus register: 5138 Data type: Float Access: read/write</p>	<p>Prerequisite This function is not available if OFF was selected in the ASSIGN LOW FLOW CUT OFF function (→ 38).</p> <p>Description Use this function to enter the on-value for low flow cut off. The unit is taken from the SYSTEM UNITS group (→ 8). Low flow cut off is switched on if the value entered is not equal to 0. An inverted plus sign is shown on the local display of the flow value as soon as the low flow cut off is active.</p> <p>User input 5-digit floating-point number</p> <p>Factory setting 1% of calibrated full scale value</p>
<p>OFF-VALUE LOW FLOW CUT OFF</p> <p>Modbus register: 5104 Data type: Float Access: read/write</p>	<p>Description Use this function to enter the off-value for low flow cut off. Enter the off-value as a positive hysteresis from the on-value.</p>  <p>The graph plots flow rate Q on the vertical axis against time t on the horizontal axis. A fluctuating line represents the flow rate. Two horizontal dashed lines, labeled 'a' and 'b', represent the ON and OFF values for the low flow cutoff. Line 'a' is lower than line 'b'. The vertical distance between 'a' and 'b' is labeled 'H', representing hysteresis. Two shaded regions under the flow rate line, labeled 'c', indicate periods where the flow rate is between 'a' and 'b'. The first shaded region starts at a point labeled '1' and ends at a point labeled '2'. The second shaded region also starts at a point labeled '1' and ends at a point labeled '2'. The points '1' and '2' are marked with dots on the flow rate line.</p> <p>Fig. 4: Example for the behavior of low flow cutoff</p> <p>Q Flow rate [volume/time] t Time H Hysteresis a ON VALUE LOW FLOW CUT OFF = 20 kg/h b OFF-VALUE LOW FLOW CUTOFF = 10% c Low flow cutoff active 1 Low flow cut off is switched on at 20 kg/h 2 Low flow cut off is switched off at 22 kg/h</p> <p>User input Integer 0 to 100%</p> <p>Factory setting 50%</p>

A0001245

Function description, PROCESS PARAMETER group	
<p>ZERO POINT ADJUST</p> <p>Modbus register: 5121 Data type: Integer Access: read/write</p>	<p>Description Use this function to start automatic zero point adjustment.</p> <p> Caution! Prior to performing zero point adjustment, observe the exact procedure for zero point adjustment as specified in Operating Instructions BA00115D/06.</p> <p> Note!</p> <ul style="list-style-type: none"> ■ Programming is locked during zero point adjustment and the display shows the notice message #561 "ZERO-ADJ. RUN". ■ If the zero point adjustment is not possible, due to unstable flow conditions, then the alarm message #451 "ZERO-ADJ.N.OK" is shown on the display. ■ After Zero point adjustment is completed, the new zero point can be called up with the  key. If the  key is pressed again, you return to the ZERO POINT ADJUST function. ■ RESET restores the factory calibration. ■ If the status input is configured appropriately, zero point adjustment can also be activated using the status input (see the ASSIGN STATUS INPUT function →  32). <p>Options 0 = CANCEL 1 = START 3 = RESET</p> <p>Factory setting CANCEL</p>
<p>INSTALLATION FACTOR</p> <p>Modbus register: 5266 Data type: Float Access: read/write</p>	<p>Description Disturbances in the flow may arise due to the design of the system, such as pipe bends, reducers, etc. The flow value measured is scaled by entering a constant factor. The flow disturbance can thus be compensated using the calculated flow signal:</p> <p>Flow output = measured flow × installation factor</p> <p>Enter a higher value: flow value output is increased. Enter a lower value: flow value output is decreased.</p> <p>User input 5-digit floating-point number 0.0000 to 99999</p> <p>Factory setting 1.0000</p>

13 GAS

Function description, GAS group

Prerequisite

This function is **not** available if the IN-SITU CALIBRATION function is enabled. This function is available again if the in-situ calibration is reset to the factory setting. Contact your Endress+Hauser service organization for more information.

Description

Use this function to view or change the gas configuration

- The device can be configured with one or two independent gas groups.
- Switching between two groups can be performed manually (function **SELECT GROUP** →  42)

General programming rules:

- A gas group can be configured with 1 single gas or a gas mixture (max. 8 gas constituents).
- The sum of the gas mixture constituents entered must total 100.0 Mole %.
- A gas constituent and its corresponding Mole % can be entered in any order within the mixture.
- A gas constituent may have a value of 0.0 Mole % within the mixture.
- The option NOT USED is only a place holder for functions **GAS TYPE 1** and **GAS TYPE 2 to 8** where there is no gas assigned. The program does not use this option for calculations.
- The option SPECIAL GAS is a substitute for other gases. The Mole % value is always 100.0%



Note!

For a flowchart of the GAS QUICK SETUP, see Operating Instructions BA00115D/06

Programming examples

- a. 1 gas group: 1 standard gas

SELECT GROUP	GAS GROUP 1
NUMBER OF GASES	1
GAS TYPE 1	AIR
MOLE % GAS 1	100.0 %

- b. 2 gas groups: 2 standard gases

SELECT GROUP	GAS GROUP 1	GAS GROUP 2
NUMBER OF GASES	1	1
GAS TYPE 1	ARGON	NITROGEN
MOLE % GAS 1	100.0 %	100.0 %

- c. 2 gas groups: 1 standard gas, 1 special gas

SELECT GROUP	GAS GROUP 1	GAS GROUP 2
NUMBER OF GASES	1	1
GAS TYPE 1	OXYGEN	SPECIAL GAS
MOLE % GAS 1	100.0 %	100.0 %
DESCRIPTION	–	O2 90% OZONE 10%
CORRECTION FACTOR	–	1.2009
REFERENCE DENSITY	–	1.5005 kg/m ³

Function description, GAS group	
<p>SELECT GROUP</p> <p>Modbus register 9798 Data type: Integer Access: read/write</p>	<p>Description</p> <ul style="list-style-type: none"> ▪ select a gas group for editing ▪ set the active gas group manually <p>Setting the active gas group:</p> <ul style="list-style-type: none"> ▪ On completion of programming all the necessary functions in the gas group, select YES in the SAVE CHANGES function →  42, or ▪ If the gas group is already programmed as required, simply select the required gas group and then exit using the ESC keys (X). <p>Options 0 = GAS GROUP 1 1 = GAS GROUP 2</p> <p>Factory setting GAS GROUP 1</p>
<p>ANALYZER INPUT</p> <p>Modbus register 5276 Data type: Integer Access: read/write</p>	<p>Description Use this function to activate/deactivate automatic updating of gas mixtures (via a gas analyzer signal). A gas group must contain at least 2 gas types (e.g. Methane 60%, Carbon Dioxide 40%).</p> <p>User input OFF ON</p> <p>Factory setting OFF</p>
<p>NUMBER OF GASES</p> <p>Modbus register 9717 Data type: Float Access: read/write</p>	<p>Description Use this function to enter the number of gases that are used in the gas group.</p> <p>User input 1 to 8</p> <p>Factory setting 1</p>
<p>GAS TYPE 1</p> <p>Modbus register 9719 Data type: Integer Access: read/write</p>	<p>Description Use this function to select gas type 1.</p> <p>Options 0 = AIR 1 = AMMONIA 2 = ARGON 3 = BUTANE 4 = CARBON DIOXIDE 5 = CARBON MONOXIDE 6 = CHLORINE 7 = ETHANE 8 = ETHYLENE 9 = HELIUM 4 10 = HYDROGEN NORMAL 11 = HYDROGEN CHLORIDE 12 = HYDROGEN SULFIDE 13 = KRYPTON 14 = METHANE 15 = NEON 16 = NITROGEN 17 = OXYGEN 18 = PROPANE 20 = XENON 22 = NOT USED 23 = SPECIAL GAS</p> <p>Factory setting AIR</p>

Function description, GAS group	
<p>MOLE % GAS 1</p> <p>Modbus register 9720 Data type: Float Access: read/write</p>	<p>Prerequisite This function is not available if the setting in NUMBER OF GASES (→ 42) is 1. (The factory setting 100% is automatically used)</p> <p>Description Use this function to enter the Mole % of the gas selected in GAS TYPE 1.</p> <p>User input 000.00 % to 100.00 %</p> <p>Factory setting 100.00 %</p>
<p>DESCRIPTION</p> <p>Modbus register 9957 Data type: String Access: (16) read/write</p>	<p>Prerequisite This function is only available if the option SPECIAL GAS is selected in the function GAS TYPE 1 (→ 42).</p> <p>Description Use this function to enter a description for a special gas configuration.</p> <p>Example A special composition consisting of 93% oxygen and 7% ozone. User input: O2 93% OZONE 7%</p> <p>User input xxxx (max. 16 characters) Valid characters are A-Z, 0-9, +, -, decimal point, blank space or underscore</p> <p>Factory setting "-----" (no text)</p>
<p>CORRECTION FACTOR</p> <p>Modbus register 9794 Data type: Float Access: read/write</p>	<p>Prerequisite This function is only available if the option SPECIAL GAS is selected in the function GAS TYPE 1 (→ 42).</p> <p>Description Use this function to enter a manual correction factor for a special gas configuration. The correction factor is normally based on air and at the specified process conditions. The correction factor is determined by the factory. If the gas or process conditions change from the initial setting, then the correction factor value will also need updating.</p> <p>User input 5-digit floating-point number</p> <p>Factory setting 1.0</p>

Function description, GAS group	
<p>REFERENCE DENSITY</p> <p>Modbus register 9764 Data type: Float Access: read/write</p>	<p>Prerequisite This function is only available if the option SPECIAL GAS is selected in the function GAS TYPE 1 (→ ☰ 42).</p> <p>Description Use this function to enter a reference density for a special gas configuration when corrected volume flow is required, e.g. Nm³ (Sft³) The unit is taken from the function UNIT DENSITY (→ ☰ 10). The reference density is determined by the factory. If the gas or reference conditions change from the initial setting, then the reference density value will also need updating.</p> <p>User input 5-digit floating-point number, with unit</p> <p>Factory setting 1.2930 [kg/m³] or 0.0807 [lb/ft³] (country dependent → ☰ 58)</p>
<p>GAS TYPE 2 to 8</p> <p>Modbus register</p> <p>GAS TYPE 2 9722 GAS TYPE 3 9725 GAS TYPE 4 9728 GAS TYPE 5 9731 GAS TYPE 6 9734 GAS TYPE 7 9737 GAS TYPE 8 9740 Data type: Integer Access: read/write</p>	<p>Prerequisite The number of functions available here is dependent upon the setting in the function NUMBER OF GASES (→ ☰ 42).</p> <p>Description Use this function to select the gas type.</p> <p>Options 0 = AIR 1 = AMMONIA 2 = ARGON 3 = BUTANE 4 = CARBON DIOXIDE 5 = CARBON MONOXIDE 6 = CHLORINE 7 = ETHANE 8 = ETHYLENE 9 = HELIUM 4 10 = HYDROGEN NORMAL 11 = HYDROGEN CHLORIDE 12 = HYDROGEN SULFIDE 13 = KRYPTON 14 = METHANE 15 = NEON 16 = NITROGEN 17 = OXYGEN 18 = PROPANE 20 = XENON 22 = NOT USED</p> <p>Factory setting NOT USED</p>

Function description, GAS group	
<p>MOLE % GAS 2 to 8</p> <p>Modbus register MOLE-% GAS 2 9723 MOLE-% GAS 3 9726 MOLE-% GAS 4 9729 MOLE-% GAS 5 9732 MOLE-% GAS 6 9735 MOLE-% GAS 7 9738 MOLE-% GAS 8 9741 Data type: Float Access: read/write</p>	<p>Prerequisite The number of functions available here is dependent upon the setting in the function NUMBER OF GASES (→ 42).</p> <p>Description Use this function to enter the Mole % of the gas selected in GAS TYPE 2 to 8.</p> <p>User input 000.00 % to 100.00 %</p> <p>Factory setting 100.00 %</p>
<p>CHECK VALUES</p> <p>Modbus register 9763 Data type: Integer Access: read/write</p>	<p>Prerequisite This function is only available if there is an error in the Mole % values.</p> <p>Description The error message MIXTURE NOT 100% appears if the entered values do not add up to 100%. The entries have to be checked and corrected before the gas group can be saved and used for flow measurement (see option YES[®] function SAVE CHANGES (→ 45)).</p> <p>Display 0 = OK (only via Modbus communication) 1 = MIXTURE NOT 100% 2 = MIXTURE ERROR (only via Modbus communication)</p>
<p>SAVE CHANGES</p> <p>Modbus register 9743 Data type: Integer Access: read/write</p>	<p>Description Use this function to control the way entries are saved in the gas group and utilized for flow measurement.</p> <p>Options 0 = YES The entered parameters are saved in the gas group and are used for flow measurement.</p> <p>1 = CANCEL The entered parameters are saved in the gas group but they are not used for flow measurement. The gas group can be activated, at a later time, by returning to the group, checking the parameters and then selecting the option YES in this function</p> <p>2 = DISCARD The entered parameters are not saved. The previous parameters remain valid and are used for flow measurement.</p>

14 HEAT FLOW





Function description, HEAT FLOW group	
<p>CALORIFIC VALUE TYPE</p> <p>Modbus register 9977 Data type: Integer Access: read/write</p>	<p>Description Use this function to select the measured variable on which the combustion value is based.</p> <p>Options 0 = MASS 1 = CORRECTED VOLUME</p> <p>Factory setting MASS</p>
<p>MODE 1</p> <p>Modbus register 9973 Data type: Integer Access: read/write</p>	<p>Description Use this function to select a mode for calculating the heat flow (GAS GROUP 1).</p> <p>Options 0 = AUTO NET 1 = AUTO GROSS 2 = MANUAL</p> <p>Factory setting AUTO NET</p>
<p>HEATING VALUE 1</p> <p>Modbus register 9975 Data type: Float Access: read/write</p>	<p>Prerequisite This function is only available if MANUAL was selected in the MODE 1 function (→ 46).</p> <p>Description Use this function to enter a user-specific calorific value.</p> <p>Input/display 5-digit floating-point number</p> <p>Factory setting 0.0 The corresponding unit is taken from the UNIT CALORIFIC VALUE MASS (→ 9) or UNIT CALORIFIC VALUE CORRECTED VOLUME function (→ 9).</p>
<p>MODE 2</p> <p>Modbus register 9974 Data type: Integer Access: read/write</p>	<p>Description Use this function to select a mode for calculating the heat flow (GAS GROUP 2).</p> <p>Options 0 = AUTO NET 1 = AUTO GROSS 2 = MANUAL</p> <p>Factory setting AUTO NET</p>
<p>HEATING VALUE 2</p> <p>Modbus register 9978 Data type: Float Access: read/write</p>	<p>Prerequisite This function is only available if MANUAL was selected in the MODE 2 function (→ 46).</p> <p>Description Use this function to enter a user-specific calorific value.</p> <p>Input/display 5-digit floating-point number</p> <p>Factory setting 0.0 The corresponding unit is taken from the UNIT CALORIFIC VALUE MASS (→ 9) or UNIT CALORIFIC VALUE CORRECTED VOLUME function (→ 9).</p>

Function description, HEAT FLOW group	
<p>REFERENCE COMBUSTION TEMPERATURE</p> <p>Modbus register 9982 Data type: Float Access: read/write</p>	<p>Prerequisite This function is not available if the option MANUAL is selected in MODE 1 or MODE 2 (→ 46).</p> <p>Description Use this function to enter the reference combustion temperature of the gas. This function is used to calculate the calorific value of the gas. The unit is taken from the function UNIT TEMPERATURE (→ 10).</p> <p>User input 5-digit floating-point number</p> <p>Factory setting 25.0 °C or 60.0 °F (country dependent → 58)</p>

15 SYSTEM PARAMETER

Function description, SYSTEM PARAMETER group	
<p>POSITIVE ZERO RETURN</p> <p>Modbus register 5503 Data type: Integer Access: read/write</p>	<p>Description Use this function to interrupt evaluation of measured variables. For example, the output signal should be set to zero flow during operations such as pipe cleaning.</p> <p>The setting acts on all functions and outputs of the measuring device. If the positive zero return is active, the notice message #601 "POSITIVE ZERO-RET" is displayed.</p> <p>If the status input is appropriately configured, the positive zero return function can also be activated by using the status input (ASSIGN STATUS INPUT →  32).</p> <p>Options 0 = OFF 1 = ON (signal output is set to zero flow value, temperature is as normal)</p> <p>Factory setting OFF</p>
<p>FLOW DAMPING</p> <p>Modbus register 5510 Data type: Float Access: read/write</p>	<p>Description For setting the filter depth. The sensitivity of the flow measurement signal can be reduced with respect to transient flows and interference peaks. The response time of the measuring device increases with every increase in the filter setting.</p> <p>The damping acts prior to other damping functions (e. g. display, time constant).</p> <p>User input 0 to 100 s</p> <p>Factory setting 1 s</p>

16 SENSOR DATA

Function description, SENSOR DATA group	
<p>This group of functions contains the essential data relating to the sensor geometry and calibration.</p> <p>Flange version (t-mass 65F): The sensor data cannot be changed and is read only.</p> <p>Insertion version (t-mass 65I): The sensor data can be changed to suit the application pipe. The pipe or duct dimensions are essential for calculating the correct insertion depth.</p> <p>All the sensor's parameter settings are saved on the HistoROM/S-DAT memory chip.</p> <p> Note! To record the sensor data for the insertion sensor (t-mass 65I), see the flowchart of the QUICK SETUP SENSOR →  12.</p>	
<p>PIPE TYPE</p> <p>Modbus register 9603 Data type: Integer Access: read/write</p>	<p>Prerequisite This function is only available for insertion sensors (t-mass 65I).</p> <p>Description Use this function to select the type of pipe.</p> <p>Options 0 = CIRCULAR 1 = RECTANGULAR</p> <p>Factory setting CIRCULAR</p>
<p>PIPE STANDARD</p> <p>Modbus register 9631 Data type: Integer Access: read/write</p>	<p>Prerequisite This function is only available for insertion sensors (t-mass 65I). This function is not available if RECTANGULAR is selected in the PIPE TYPE function (→  49).</p> <p>Description Use this function to select a pipe standard. If the option OTHERS is selected here, then values need to be entered in the functions OUTER DIAMETER and WALL THICKNESS.</p> <p>Options</p> <p>ANSI B3610 0 = SCHEDULE 10 1 = SCHEDULE 20 2 = SCHEDULE 30 3 = SCHEDULE 40 4 = SCHEDULE 60 5 = SCHEDULE 80</p> <p>ANSI B3619 6 = SCHEDULE 10 7 = SCHEDULE 40 8 = SCHEDULE 80</p> <p>DIN 9 = PN6 10 = PN10 11 = PN16 12 = PN25 13 = PN40</p> <p>14 = OTHERS</p> <p>Factory setting PN10 or B36.10 SCHEDULE 10 (country dependent →  58)</p>

Function description, SENSOR DATA group	
<p>NOMINAL DIAMETER</p> <p>Modbus register 9632 Data type: Integer Access: read/write</p>	<p>Prerequisite This function is only available for insertion sensors (t-mass 651). This function is not available if OTHER was selected in the PIPE STANDARD function (→ 49) or RECTANGULAR in the PIPE TYPE function (→ 49).</p> <p>Description Use this function to select the nominal diameter of the pipe.</p> <p>Options 0 = 80 resp. 3" 1 = 100 resp. 4" 2 = 150 resp. 6" 3 = 200 resp. 8" 4 = 250 resp. 10" 5 = 300 resp. 12" 6 = 350 resp. 14" 7 = 400 resp. 16" 8 = 450 resp. 18" 9 = 500 resp. 20" 10 = 600 resp. 24" 11 = 700 resp. 28" 12 = 800 resp. 32" 13 = 900 resp. 36" 14 = 1000 resp. 40"</p> <p>Factory setting 150 resp. 6"</p>
<p>OUTER DIAMETER</p> <p>Modbus register 9633 Data type: Float Access: read/write</p>	<p>Prerequisite This function is only available for insertion sensors (t-mass 651). This function is only available if CIRCULAR is selected in the function PIPE TYPE (→ 49) and OTHER was selected in the function PIPE STANDARD (→ 49).</p> <p>Description Use this function to enter a value for the outer diameter if the required pipe standard was not available in the function PIPE STANDARD (→ 49). The unit is taken from the function UNIT LENGTH (→ 11).</p> <p>User input 5-digit floating-point number 60 to 99999 (mm) or 2.362 to 3937 (inch) (country dependent → 58)</p> <p>Factory setting 168.3 (mm) or 6.0 (inch) (country dependent → 58)</p>
<p>WALL THICKNESS</p> <p>Modbus register 9629 Data type: Float Access: read/write</p>	<p>Prerequisite This function is only available for insertion sensors (t-mass 651). This function is only available if OTHER was selected in the PIPE STANDARD function (→ 49).</p> <p>Description Use this function to enter the wall thickness of a circular or rectangular duct. The unit is taken from the function UNIT LENGTH (→ 11).</p> <p>User input 5-digit floating-point number 2.0 to 40.0 (mm) or 0.08 to 1.57 (inch) (country dependent → 58)</p> <p>Factory setting 4.5 (mm) or 0.1771 (inch) (country dependent → 58)</p>

Function description, SENSOR DATA group	
<p>INTERNAL DIAMETER</p> <p>Modbus register 9604 Data type: Float Access: read</p>	<p>Prerequisite This function is only available for insertion sensors (t-mass 65I). This function is only available if OTHER is selected in the function PIPE STANDARD (→ 49) and CIRCULAR was selected in the function PIPE TYPE (→ 49).</p> <p>Description Use this function to view the internal diameter of a circular pipe. The unit is taken from the function UNIT LENGTH (→ 11).</p> <p>Display 5-digit floating-point number</p> <p>Factory setting Depends on the sensor size (country dependent → 58)</p>
<p>INTERNAL HEIGHT</p> <p>Modbus register 9606 Data type: Float Access: read/write</p>	<p>Prerequisite This function is only available for insertion sensors (t-mass 65I). This function is only available if RECTANGULAR is selected in the PIPE TYPE function (→ 49).</p> <p>Description Use this function to enter the internal height of a rectangular duct. The unit is taken from the function UNIT LENGTH (→ 11).</p> <p>User input 5-digit floating-point number 45 to 99999 (mm) or 1.771 to 3937 (inch) (country dependent → 58)</p> <p>Factory setting 150.0 (mm) or 6.0 (inch) (country dependent → 58)</p>
<p>INTERNAL WIDTH</p> <p>Modbus register 9608 Data type: Float Access: read/write</p>	<p>Prerequisite This function is only available for insertion sensors (t-mass 65I). This function is only available if RECTANGULAR is selected in the PIPE TYPE function (→ 49).</p> <p>Description Use this function to enter the internal width of a rectangular duct. The unit is taken from the function UNIT LENGTH (→ 11).</p> <p>User input 5-digit floating-point number 45 to 99999 (mm) or 1.771 to 3937 (inch) (country dependent → 58)</p> <p>Factory setting 150.0 (mm) or 6.0 (inch) (country dependent → 58)</p>
<p>MOUNTING</p> <p>Modbus register 9628 Data type: Integer Access: read/write</p>	<p>Prerequisite This function is only available for insertion sensors (t-mass 65I). This function is only available if RECTANGULAR is selected in the PIPE TYPE function (→ 49).</p> <p>Description Use this function to select the installation direction of the insertion sensor in the rectangular duct.</p> <ul style="list-style-type: none"> – If the VERTICAL option is selected, the value from the function INTERNAL HEIGHT (→ 51) is used to calculate the insertion depth – If the HORIZONTAL option is selected, the value from the function INTERNAL WIDTH (→ 51) is used to calculate the insertion depth <p>Options 0 = HORIZONTAL 1 = VERTICAL</p> <p>Factory setting VERTICAL</p>





Function description, SENSOR DATA group	
<p>MOUNTING SET LENGTH</p> <p>Modbus register 9635 Data type: Float Access: read/write</p>	<p>Prerequisite This function is only available for insertion sensors (t-mass 65l).</p> <p>Description Use this function to enter a value for the length of the mounting set (including the sensor compression fitting). The unit is taken from the function UNIT LENGTH (→ 11).</p> <p>User input 5-digit floating-point number 75 to 900 (mm) or 2.953 to 35.433 (inch) (country dependent → 58)</p> <p>Factory setting 106.0 (mm) or 4.173 (inch) (country dependent → 58) The factory setting value is the length of the G1A compression fitting and standard Endress+Hauser mounting boss.</p>
<p>INSERTION DEPTH</p> <p>Modbus register 9637 Data type: Float Access: read</p>	<p>Prerequisite This function is only available for insertion sensors (t-mass 65l).</p> <p>Description This function displays the calculated insertion depth for mounting the sensor. The unit is taken from the function UNIT LENGTH (→ 11). For more information on insertion depth calculation, please refer to the Operating Instructions BA00115D/06.</p> <p>Display 5-digit floating-point number</p>
<p>ZERO POINT</p> <p>Modbus register 9624 Data type: Integer Access: read/write</p>	<p>Description This function shows the current zero point correction value for the sensor. The zero point is determined by the ZERO POINT ADJUST (→ 40) function.</p> <p>User input 5-digit floating-point number -20.000 to +20.000</p> <p>Factory setting Depends on calibration.</p>
<p>FLOW CONDITIONER</p> <p>Modbus register 9626 Data type: Integer Access: read</p>	<p>Description Use this function to indicate if the t-mass 65F sensor has been calibrated with or without a flow conditioner.</p> <p>Display 0 = WITH 1 = WITHOUT</p> <p>Factory setting WITHOUT</p>
<p>CALIBRATION DATE</p> <p>Modbus register 9641 Data type: String Access: (16) read/write</p>	<p>Description Use this function to display the date of the last factory calibration of the measuring device. This date is not updated by the IN-SITU CALIBRATION function.</p> <p>Options DD.MM.YYYY</p>

17 SUPERVISION

Function description, SUPERVISION group	
<p>ACTUAL SYSTEM CONDITION</p> <p>Modbus register 6859 Data type: Integer Access: read Modbus register 6821 Data type: String (16)</p>	<p>Description The current system status appears on the display.</p> <p>Display SYSTEM OK or The fault/notice message with the highest priority. Modbus error codes: Operating Instructions BA00115D/06</p>
<p>PREVIOUS SYSTEM CONDITION</p> <p>Modbus register 6830 Data type: String (16) Modbus register 6860...6875 Data type: Integer Access: read</p>	<p>Description The last 16 fault and notice messages appear on the display. Modbus error codes: Operating Instructions BA00115D/06</p>
<p>ALARM DELAY</p> <p>Modbus register 6808 Data type: Float Access: read/write</p>	<p>Description Use this function to enter a time delay for which the criteria for an error always has to be satisfied before a fault or notice message is generated. Depending on the setting and the type of error, this suppression acts on the display and Modbus communication.</p> <p> Note! If this function is activated fault and notice messages are delayed by the time corresponding to the setting before being forwarded to the Modbus communication. Therefore, check in advance whether a delay of this nature could affect the safety requirements of the process. If fault and notice messages are not be suppressed, than a value of 0 seconds must be entered here.</p> <p>User input 0 to 100 s (in steps of one second)</p> <p>Factory setting 0 s</p>
<p>SYSTEM RESET</p> <p>Modbus register 6817 Data type: Integer Access: read/write</p>	<p>Description Use this function to restart (reset) the measuring device.</p> <p>Options 0 = NO The device is not restarted. 1 = RESTART SYSTEM Restart without disconnecting main power. In doing so, all the data (functions) are accepted unchanged.</p> <p>Factory setting NO</p>
<p>OPERATION HOURS</p> <p>Modbus register 6810 Data type: Float Access: read</p>	<p>Description The hours of operation of the device appear on the display.</p> <p>Display Depends on the number of hours of operation elapsed: Hours of operation < 10 hours → display format = 0:00:00 (hr:min:sec) Hours of operation 10 to 10 000 hours → display format = 0000:00 (hr:min) Hours of operation > 10 000 hours → display format = 000000 (hr)</p>

Function description, SUPERVISION group	
HOURS SINCE RESET	Description The hours of operation since the last reset of the device appear on the display.
Modbus register 6878	Display Depends on the number of hours of operation elapsed: Hours of operation < 10 hours → display format = 0:00:00 (hr:min:sec) Hours of operation 10 to 10 000 hours → display format = 0000:00 (hr:min) Hours of operation >10 000 hours → display format = 000000 (hr)
Data type: Float	
Access: read	

18 SIMULATION SYSTEM

Function description, SIMULATION SYSTEM group	
<p>SIMULATION FAILSAFE MODE</p> <p>Modbus register: 6812 Data type: Integer Access: read/write</p>	<p>Description Use this function to set all inputs, outputs and the totalizer to their error response modes, in order to check whether they respond correctly. During this time, the message #691 "SIMULATION FAILSAFE" appears on the display.</p> <p>Options 0 = OFF 1 = ON</p> <p>Factory setting OFF</p>
<p>SIMULATION MEASURAND</p> <p>Modbus register: 6813 Data type: Integer Access: read/write</p>	<p>Description Use this function to set all the inputs, outputs and the totalizer to their flow response modes, in order to check whether they respond correctly. During this time, the message #692 "SIMULATION MEASURAND" appears on the display.</p> <p> Note!</p> <ul style="list-style-type: none"> The measuring device can only be used for measuring to a certain extent while the simulation is in progress. The setting is not saved if the power supply fails. <p>Options 0 = OFF 1 = MASS FLOW 2 = CORRECTED VOLUME FLOW 3 = TEMPERATURE 4 = HEAT FLOW</p> <p>Factory setting OFF</p>
<p>VALUE SIMULATION MEASURAND</p> <p>Modbus register: 6814 Data type: Float Access: read/write</p>	<p>Prerequisite Function is only available if the SIMULATION MEASURAND function (→  55) is active.</p> <p>Description Use this function to specify an arbitrary value (e.g. 12 kg/s) to check the assigned functions in the device itself and downstream signal circuits. The unit depends on the option selected in the SIMULATION MEASURAND function and is taken from the SYSTEM UNITS group (→  8).</p> <p> Note! The setting is not saved if the power supply fails.</p> <p>User input 5-digit floating-point number</p> <p>Factory setting (country dependent →  58)</p> <ul style="list-style-type: none"> 0 kg/h; 0 lb/h (MASS FLOW) 0 Nm³/h; 0 Sm³/h (CORRECTED VOLUME FLOW) 0 MWh; 0 kBtu (HEAT FLOW) 0 °C; +32 °F (TEMPERATURE)

19 SENSOR VERSION

Function description, SENSOR VERSION group	
<p>SENSOR TYPE</p> <p>Modbus register 7012 Data type: Integer Access: read/write</p>	<p>Description Use this function to view the sensor type.</p> <p>Display 0 = FLOWCELL (t-mass 65F flange sensor) 1 = INSERTION (t-mass 65I insertion sensor)</p>
<p>SERIAL NUMBER</p> <p>Modbus register 7003 Data type: String Access: (16) read</p>	<p>Description The serial number of the sensor appears on the display.</p>
<p>TRANSDUCER SERIAL NUMBER</p> <p>Modbus register 7461 Data type: String Access: (16) read</p>	<p>Description The serial number of the transducer appears on the display.</p>
<p>SOFTWARE REVISION NUMBER S-DAT</p> <p>Modbus register 7021 Data type: String Access: (16) read</p>	<p>Description Use this function to view the software revision number of the S-DAT.</p>
<p>PRE-AMPLIFIER SOFTWARE REVISION NUMBER</p> <p>Modbus register 7469 Data type: String Access: (16) read</p>	<p>Description Use this function to view the software revision number of the preamplifier.</p>
<p>PRE-AMPLIFIER HARDWARE REVISION NUMBER</p> <p>Modbus register 7477 Data type: String Access: (16) read</p>	<p>Description Use this function to view the hardware revision number of the preamplifier.</p>

20 AMPLIFIER VERSION

Function description, AMPLIFIER VERSION group	
<p>DEVICE SOFTWARE</p> <p>Modbus register 7277 Data type: String Access: (16) read</p>	<p>Description Use this function to display the current device software version.</p>
<p>HARDWARE REVISION NUMBER AMPLIFIER</p> <p>Modbus register 7030 Data type: String Access: (16) read</p>	<p>Description Use this function to view the hardware revision number of the amplifier board.</p>
<p>SOFTWARE REVISION NUMBER AMPLIFIER</p> <p>Modbus register 7039 Data type: String Access: (16) read</p>	<p>Description Use this function to view the software revision number of the amplifier board.</p>
<p>SOFTWARE REVISION NUMBER T-DAT</p> <p>Modbus register 7048 Data type: String Access: (16) read</p>	<p>Description Use this function to view the software revision number of the T-DAT.</p>
<p>I/O MODULE TYPE</p> <p>Modbus register 7285 Data type: Integer Access: read</p>	<p>Description Use this function to view the configuration of the I/O module.</p>
<p>SOFTWARE REVISION NUMBER I/O MODULE</p> <p>Modbus register 7078 Data type: String Access: (16) read</p>	<p>Description Use this function to view the software revision number of the I/O module.</p>

21 Factory settings

21.1 Language → 24

Country	Language	Country	Language
Australia	English	Norway	Norwegian
Belgium	English	Austria	German
Denmark	English	Poland	Polish
Germany	German	Portugal	Portuguese
England	English	Sweden	Swedish
Finland	Finnish	Switzerland	German
France	French	Singapore	English
The Netherlands	Dutch	Spain	Spanish
Hong Kong	English	South Africa	English
India	English	Thailand	English
Italy	Italian	Czechia	Czech
Luxembourg	French	Hungary	English
Malaysia	English	Other countries	English

21.2 SI units (not for USA and Canada)

21.2.1 Low flow cut off, full scale value, pulse value

t-mass F sensor

With air at ambient conditions (without a flow conditioner)

Nominal diameter [mm]	Low flow cut off [kg/h]	Full scale value [kg/h]	Pulse value [kg/p]
15	0.53	53	0.10
25	2.00	200	1.00
40	5.55	555	1.00
50	9.10	910	10.00
80	20.30	2030	10.00
100	37.50	3750	10.00

t-mass I sensor

With air at ambient conditions (without a flow conditioner)

Nominal diameter [mm]	Low flow cut off [kg/h]	Full scale value [kg/h]	Pulse value [kg/p]
80	20.30	2030	10.0
100	37.50	3750	10.0
150	75.00	7500	100.0
200	125.00	12500	100.0

Nominal diameter	Low flow cut off	Full scale value	Pulse value
[mm]	[kg/h]	[kg/h]	[kg/p]
250	200.00	20000	100.0
300	280.00	28000	100.0
400	500.00	50000	100.0
500	800.00	80000	100.0
600	1150.00	115000	100.0
700	1590.00	159000	100.0
1000	3200.00	320000	100.0
1500	7200.00	720000	100.0

21.2.2 System units → 8

	Unit
Temperature	°C
Density	kg/m ³
Reference density	kg/m ³
Calorific Value Mass	MJ/kg
Heat	kWh



	Unit
Length	mm
Pressure	bar a
Reference Pressure	bar a
Calorific Value Corr. Vol.	MJ/m ³
Reference temperature	°C

21.2.3 Unit totalizer 1 and 2 → 29

	Unit
Mass flow	kg
Heat flow	MWh

	Unit
Corrected volume flow	Nm ³

21.2.4 Other Units

	Unit	
Ref. combustion temp.	°C	→  47
Pipe standard	according to DIN	→  49

21.3 US units (only for USA and Canada)

21.3.1 Low flow cut off, full scale value, pulse value

t-mass F sensor

With air at ambient conditions; (without a flow conditioner)

Nominal diameter [mm]	Low flow cut off [lb/hr]	Full scale value [lb/hr]	Pulse value [lb/p]
½"	1.16	116	0.20
1"	4.40	440	2.00
1½"	12.20	1220	2.00
2"	20.02	2002	20.00
3"	44.66	4466	20.00
4"	82.50	8250	20.00

t-mass I sensor

With air at ambient conditions; (without a flow conditioner)

Nominal diameter [mm]	Low flow cut off [lb/hr]	Full scale value [lb/hr]	Pulse value [lb/p]
3"	44.66	4466	20.00
4"	82.50	8250	20.00
6"	165.00	16500	200.00
8"	275.00	27500	200.00
10"	440.00	44000	200.00
12"	610.00	61000	200.00
16"	1100.00	110000	200.00
20"	1760.00	176000	200.00
24"	2530.00	253000	200.00
28"	3498.00	349800	200.00
40"	7040.00	704000	200.00
60"	15840.00	1584000	200.00

21.3.2 SYSTEM UNITS → 8

	Unit
Temperature	°F
Density	lb/ft ³
Reference density	lb/ft ³
Calorific Value Mass	kBtu/lb
Heat	kBtu



	Unit
Length	inch
Pressure	psi a
Reference Pressure	psi a
Calorific Value Corr. Vol.	kBtu/Sft ³
Reference temperature	°F

21.3.3 Unit totalizer 1 and 2 → 29

	Unit
Mass flow	lb
Heat flow	kBtu

	Unit
Corrected volume flow	Sm ³

21.3.4 Other Units

	Unit	
Ref. combustion temp.	°F	→  47
Pipe standard	according to ANSI	→  49

Index

Numerics

100% VALUE LINE 1 (fct.)	26
100% VALUE LINE 2 (fct.)	27

A

ACCESS CODE (fct.)	24
ACCESS CODE COUNTER (fct.)	25
ACTIVE LEVEL (fct.)	32
ACTUAL STATUS INPUT (fct.)	32
ACTUAL SYSTEM CONDITION (fct.)	53
ALARM DELAY (fct.)	53
AMPLIFIER VERSION, function group	57
ASSIGN LINE 1 (fct.)	26
ASSIGN LINE 2 (fct.)	26
ASSIGN LOW FLOW CUTOFF (fct.)	38
ASSIGN STATUS INPUT (fct.)	32
ASSIGN TOTALIZER (fct.)	29

B

BACKLIGHT (fct.)	28
BAUDRATE (fct.)	34
BYTE ORDER (fct.)	35

C

CALIBRATION DATE (fct.)	52
Calorific value	21
CALORIFIC VALUE TYPE (fct.)	46
CHECK VALUES (fct.)	45
Commissioning	14
COMMUNICATION, function group	34
CONTRAST LCD (fct.)	27
CORRECTED VOLUME FLOW (fct.)	7
CORRECTION FACTOR (fct.)	43

D

Data back-up (of device data with T-DAT)	23
DEFINE PRIVATE CODE (fct.)	24
DELAY TELEGRAM REPLY (fct.)	35
DESCRIPTION (fct.)	43
DEVICE SOFTWARE (fct.)	57
DISPLAY DAMPING (fct.)	27

F

FAILSAFE MODE	
FAILSAFE MODE (fct.)	31
FIELD BUS ADDRESS (fct.)	34
FLOW CONDITIONER (fct.)	52
FLOW DAMPING (fct.)	48
FORMAT (fct.)	27

G

Gas programming	18
GAS TYPE 1 (fct.)	42
GAS TYPE 2 to 8 (fct.)	44
GAS, function group	41
GROSS CALORIFIC VALUE (fct.)	38

H

HANDLING TOTALIZER, function group	31
HARDWARE REVISION NUMBER AMPLIFIER (fct.)	57
Heat flow	21
HEAT FLOW (fct.)	7
HEAT FLOW, function group	46
HEATING VALUE 1 (fct.)	46
HOURS SINCE RESET (fct.)	54

I

I/O MODULE TYPE (fct.)	57
INSERTION DEPTH (fct.)	52
INSTALLATION FACTOR (fct.)	40
INTERNAL DIAMETER (fct.)	51
INTERNAL HEIGHT (fct.)	51
INTERNAL WIDTH (fct.)	51

L

LANGUAGE (fct.)	24
-----------------	----

M

MASS FLOW (fct.)	7
MEASURED VALUES, function group	7
MINIMUM PULSE WIDTH (fct.)	32
MODE 1 (fct.)	46
MODE 2 (fct.)	46
MOLE % GAS 1 (GAS) (fct.)	43
MOLE % GAS 1 (PROCESS PARAMETER) (fct.)	38
MOLE % GAS 2 to 8	45
MOUNTING (fct.)	51
MOUNTING SET LENGTH (fct.)	52

N

NET CALORIFIC VALUE (fct.)	38
Net/gross calorific value	21
NOMINAL DIAMETER (fct.)	50
NUMBER OF GASES (fct.)	42

O

OFF-VALUE LOW FLOW CUTOFF (fct.)	39
ON-VALUE LOW FLOW CUTOFF (fct.)	39
OPERATION HOURS (fct.)	53
OPERATION, function group	24
OUTER DIAMETER (fct.)	50
OVERFLOW (fct.)	29

P

PARITY (fct.)	35
PIPE STANDARD (fct.)	49
PIPE TYPE (fct.)	49
POSITIVE ZERO RETURN (fct.)	48
PRE-AMPLIFIER HARDWARE REVISION NUMBER (fct.)	56
PRE-AMPLIFIER SOFTWARE REVISION NUMBER (fct.)	56
Pressure	
Process pressure	20

Quick setup	20
PREVIOUS SYSTEM CONDITION (fct.)	53
PROCESS PARAMETER, function group	37
Process pressure	20
PROCESS PRESSURE (fct.)	37
PROCESS PRESSURE 1 (fct.)	37
PROCESS PRESSURE 2 (fct.)	37
Process pressure, programming	20
Q	
Quick setup	
Commissioning	14
Gas programming	18
Heat flow	21
Pressure	20
Sensor	17
QUICK SETUP COMMISSIONING (fct.)	12
QUICK SETUP COMMUNICATION (fct.)	12
QUICK SETUP function group	12
QUICK SETUP GAS (fct.)	12
QUICK SETUP HEAT FLOW (fct.)	13
QUICK SETUP PRESSURE (fct.)	13
QUICK SETUP SENSOR (fct.)	12
R	
REFERENCE COMBUSTION TEMPERATURE (fct.)	47
REFERENCE DENSITY (GAS) (fct.)	44
REFERENCE DENSITY (PROCESS PARAMETER) (fct.) .	38
REFERENCE PRESSURE (fct.)	37
REFERENCE TEMPERATURE (fct.)	37
RESET ALL TOTALIZERS (fct.)	31
RESET TOTALIZER (fct.)	30
S	
SAVE CHANGES (fct.)	45
SCAN LIST REG. 1 to 16 (fct.)	36
SELECT GROUP (fct.)	42
SENSOR DATA, function group	49
Sensor setup	17
SENSOR TYPE (fct.)	56
SENSOR VERSION, function group	56
SERIAL NUMBER (fct.)	56
SIMULATION FAILSAFE MODE (fct.)	55
SIMULATION MEASURAND (fct.)	55
SIMULATION STATUS INPUT (fct.)	33
SIMULATION SYSTEM, function group	55
SOFTWARE REVISION NUMBER AMPLIFIER (fct.) ...	57
SOFTWARE REVISION NUMBER I/O MODULE (fct.) ..	57
SOFTWARE REVISION NUMBER S-DAT (fct.)	56
SOFTWARE REVISION NUMBER T-DAT (fct.)	57
STATUS ACCESS (fct.)	25
STATUS INPUT, function group	32
SUM (fct.)	29
SUPERVISION, function group	53
SYSTEM PARAMETER, function group	48
SYSTEM RESET (fct.)	53
SYSTEM UNITS, function group	8
T	
TAG NAME (fct.)	34

T-DAT (HistoROM)	
Save/load (data back-up, e.g. for replacing devices) .	23
T-DAT save/load	13
T-DAT SAVE/LOAD (fct.)	13
TEMPERATURE (fct.)	7
TEST DISPLAY (fct.)	28
TOTALIZER 1/2, function group	29
TRANSDUCER SERIAL NUMBER (fct.)	56
TRANSMISSION MODE (fct.)	34
U	
UNIT CALORIFIC VALUE CORRECTED VOLUME (fct.) ...	9
UNIT CALORIFIC VALUE MASS (fct.)	9
UNIT CORRECTED VOLUME FLOW (fct.)	8
UNIT DENSITY (fct.)	10
UNIT HEAT FLOW (fct.)	10
UNIT LENGTH (fct.)	11
UNIT MASS FLOW (fct.)	8
UNIT PRESSURE (fct.)	10
UNIT TEMPERATURE (fct.)	10
UNIT TOTALIZER (fct.)	29
USER INTERFACE, function group	26
V	
VALUE SIMULATION MEASURAND (fct.)	55
VALUE SIMULATION STATUS INPUT (fct.)	33
W	
WALL THICKNESS (fct.)	50
WRITE PROTECTION (fct.)	35
Z	
ZERO POINT (fct.)	52
ZERO POINT ADJUST (fct.)	40

www.addresses.endress.com
