

Safety Instructions

Waterpilot

FMX21

Ex ia IIC T4...T6 Gb
TÜV 14.1198



Document: XA01348P-A

Safety instructions for electrical apparatus for explosion-hazardous areas

Waterpilot FMX21

**Associated
Documentation**

This document is an integral part of the following Operating Instructions:
BA00380P/00

The Operating Instructions which are supplied and correspond to the device type apply.

**Supplementary
Documentation**

Explosion-protection brochure:
CP00021Z/11

Designation

Explanation of the labelling and type of protection can be found in the explosion protection brochure.

Designation of type of protection

Ex ia IIC T4...T6 Gb

Applied standards

**ABNT NBR IEC 60079-0 :2008
ABNT NBR IEC 60079-11:2009**

Safety instructions:
Installation

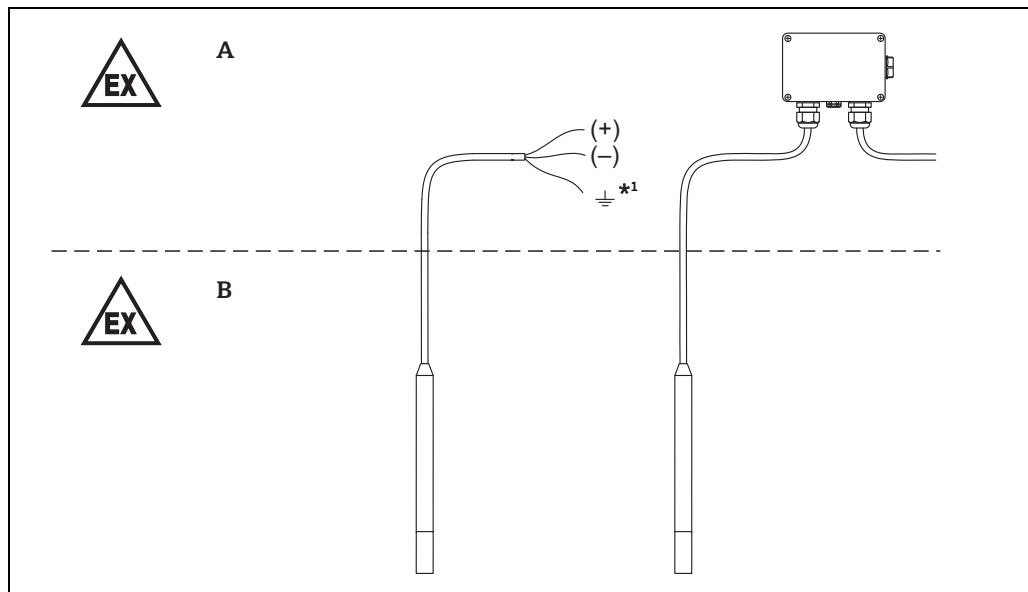

A Zone 1 or Zone 2 or Non-hazardous area

B Zone 1

*1 Only for versions with outside diameters 22 mm and 42 mm.

- Comply with the installation and safety instructions in the Operating Instructions.
- Install the device according to the manufacturer's instructions and any other valid standards and regulations.
- The type of protection changes as follows when the devices are connected to certified intrinsically safe circuits of Category ib: Ex ib.
- When interconnecting intrinsically safe circuits, take into account sensor capacitance and length-dependent cable capacitance and inductance (→ 5, "Connection data").
- Connect cable screen to earth ground of the installation.
- The intrinsically safe input power circuit of the device is isolated from ground potential and has a dielectric strength of at least $500 V_{rms}$ with respect to it.
When shortening the length of the cable ensure that this dielectric strength is maintained for connection wires and earth grounded screen.
- Avoid impact and friction sparks (anchor equipment if necessary/secure against swinging).
- Avoid electrostatic charging of the plastic surfaces (especially at the version with outside diameter 29 mm and at the terminal box).
Do not rub. Do not use in media or environments which may generate electrostatic charges on the plastic surfaces.

Terminal box

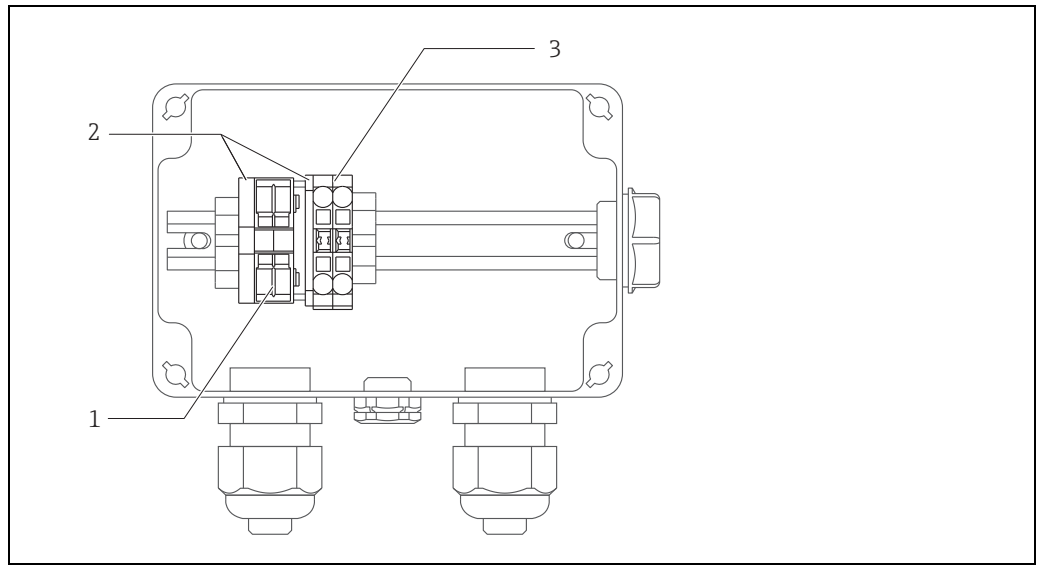

- 1 Functional earth terminals
- 2 Isolation plates
- 3 Signal terminals

- Use a connecting cable for continuous duty temperature $\geq 85\text{ }^\circ\text{C}$.
- Do not remove or move terminal blocks, isolation plates or fastening elements.
- Do not build in additional components.

Temperature tables

Ambient temperature range	Temperature class	Max. ambient temperature
$-10\text{ }^\circ\text{C} \leq T_a \leq +70\text{ }^\circ\text{C}$	T4	+70 °C
	T5	+55 °C
	T6	+40 °C

Terminal box

Ambient temperature range	Temperature class
$-40\text{ }^\circ\text{C} \leq T_a \leq +80\text{ }^\circ\text{C}$	T6

Connection data

Electrical Data
$U_i \leq 30\text{ V DC}$ $I_i \leq 133\text{ mA}$ $P_i \leq 1\text{ W}$ $C_i \leq 10.3\text{ nF} + 180\text{ pF/m}$ $L_i \leq 1\text{ }\mu\text{H/m}$



71267994

www.addresses.endress.com
