

pH/Redox Measurement *Mycom S CPM 153*

pH/Redox Measuring Transmitter (one or two-circuit) with Controller and Limit Value Functions for Ex and non-Ex areas



Applications

The four-wire transmitter Mycom S CPM 153 performs pH and redox potential measurements with the highest level of reliability and accuracy in all areas of process engineering and processing systems.

Thanks to its modular structure, you can optimally adapt the device to any measurement or control task in the following applications:

- Chemical processes
- Food technology
- Pharmaceuticals
- Water treatment
- Explosion hazardous areas 

Benefits at a glance

- High measurement reliability and user-friendliness:
 - Monitors electrode status (SCC), impedance (SCS) and measuring signal (PCS)
 - Logbook functions and data logger
 - Automatic buffer recognition
 - One-touch calibration
 - Integrated cleaning function "ChemoClean"
 - Redundancy and differential measurement
 - Online help pages
- Individually adaptable using:
 - Optional two-circuit measurement (galvanically isolated circuits)
 - Extended controller and limit value functions
 - Current/resistance inputs for feedforward control and position feedback
 - Current output for analogue actuators
 - Plug-in module to save and transfer configuration (DAT module)
 - Output contacts to NAMUR
- Ex approval
ATEX II (1) 2 G EEx em [ia/ib] IIC T4

Quality made by
Endress+Hauser



ISO 9001

Endress + Hauser

The Power of Know How



Functions and system design

Measuring system

A complete measuring system consists of the following components:

- The transmitter Mycom S CPM 153
- An immersible (e.g. CPA 140), flow (e.g. CPA 240) or retractable assembly (e.g. CPA 475), each with or without potential matching pin
- A pH/redox combination electrode with integrated or separate temperature sensor Pt 100, e.g. CPS 71
- A corresponding pH measuring cable, e.g. CPK 9

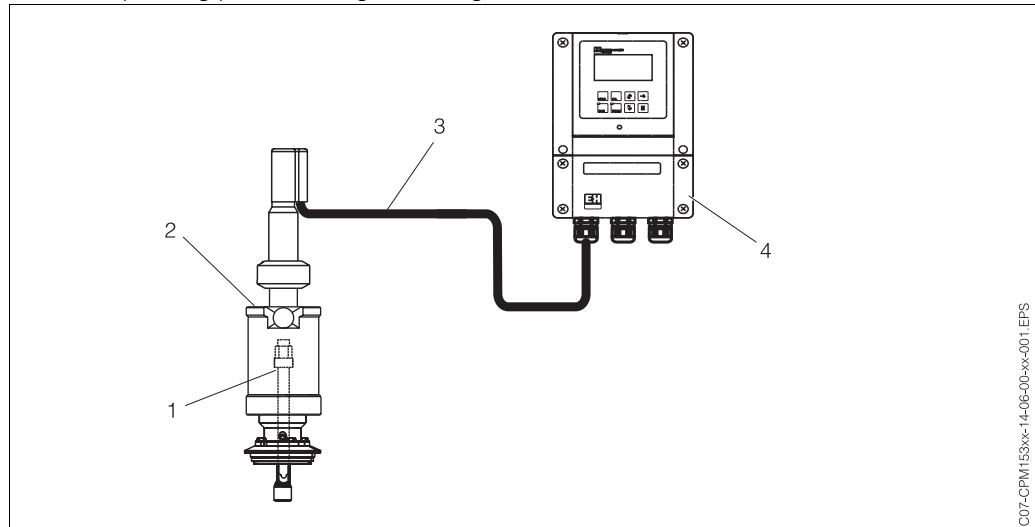

Example of a measuring system

1: CPS 71 electrode

2: CPA 475 manually retractable assembly

3: CPK 9 pH cable

4: Transmitter Mycom S CPM 153

C07-CPM153xx-14-06-00-xx-001.EPS

Functions

Quick Setup

This function configures the measuring point quickly and simply with the necessary basic settings, so that you can begin measuring immediately.

SCC (Sensor Condition Check)

This function monitors the state of the electrodes or the degree of electrode ageing. The "Electrode OK", "Low wear" or "Replace electrode" messages inform you of the state of the electrode. The electrode status is updated after each calibration. When the "Replace electrode" message appears, an error message is displayed.

SCS (Sensor Check System)

The Sensor Check System informs you of deviations in pH glass resistance or the difference between the reference resistance and the normal range. This indicates that an incorrect measurement may be made due to blocking or damage to the pH electrode.

PCS (Process Check System)

This function checks the measuring signal for deviations. If the measuring signal does not change for some time (several measured values), an alarm is triggered. Soiling, blockage or similar could be the cause of such behaviour.

Logbooks

There are several logbooks available. The last 30 entries are saved to an error logbook, an operation logbook and a calibration logbook. You can retrieve the entries by specifying a date and time.

Data logger

You can record two freely-selectable parameters using the integrated data loggers and then view the results graphically in real time. You can retrieve the last 500 measured values using date and time. In this way, you can graphically display the process flow. This is a quick way of checking the process and provides a good possibility of optimising pH control.

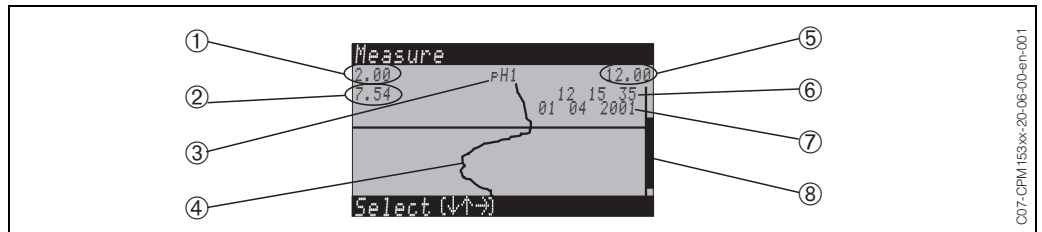

Example for data logger 1 (for Parameter 1, pH is selected here)

- | | |
|--|---|
| 1: Minimum display range (selectable to -2 pH) | 5: Maximum display range (selectable to $+16$ pH) |
| 2: The measured value which is found on the scroll bar | 6: Time when this measured value was recorded |
| 3: Recorded measured value | 7: Date of this measured value |
| 4: Measured value curve | 8: Scroll bar |

Cleaning functions

The ChemoClean[®] spray cleaning system automatically cleans the electrode. It is controlled by two contacts (possible with basic equipment). Cleaning can be triggered automatically at programmed intervals, manually or by an error message. Cleaning can be triggered by almost any error message.

In the TopClean S and TopCal S fully automatic cleaning and calibration systems, the Mycom S CPM 153 is used as a transmitter and control device. You can automate cleaning and calibration using a retractable assembly (e.g. CleanFit or ProbFit series). The superb price-performance ratio of the TopCal S and TopClean S systems allows you to install a complete measuring point with a low cost of ownership.

Simple to control

The follow control functions are used in the Mycom S CPM 153:

- Limit value contact
 - Two-point controller with hysteresis for simple temperature control, for example
- PID controller
 - for one and two-sided processes
 - with freely adjustable P, I and D components
 - Includes configurable range-dependent gain (kinked curve)
 - Differentiation between batch and flow processes
- Manipulated variable output

The manipulated variable can be output either as a binary signal via the relay or via the current output:

 - Binary signal via relay as PWM (pulse length), PFM (pulse frequency)
 - Current output (0/4 ... 20 mA): analogue signal to control actuator (for one or two actuator drives)

Valves with a repeater or feedforward control can also be included in the control system.

For this, you can use the following optional inputs:

- 1 current input (Ex or non-Ex)
- 2 current inputs (Ex or non-Ex)
- 1 resistance input (for non-Ex)
- 1 current and 1 resistance input (for non-Ex)

With the following selection aid for in-line and batch processes, you can select the right transmitter variant for your process.

PWM = pulse length proportional

PFM = pulse frequency proportional

Three PS = three-point step controller

Selection aid for online processes

Process	Path	Dosing actuators	Required hardware equipment for control				Ordering variants CPM 153-
			Circuits	Relay	Current inputs	Current outputs	
1-sided control	looking-ahead · 2-circuit · flow	1 PWM	2	1	1	-	x3x2xxxxx
		1 PFM	2	1	1	-	x3x2xxxxx
		1 three-PS	2	2	2	-	x3x4xxxxx
		1 PWM/PFM					
		current output	2	-	1	1	x3x2xxxxx
	not looking-ahead	1 PWM	1	1	-	-	x1x0xxxxx
		1 PFM	1	1	-	-	x1x0xxxxx
		1 three-PS	1	2	1	-	x1x2xxxxx
		1 PWM/PFM					
		current output	1	-	-	1	x1x0xxxxx

C07-CPM153xx-16-12-00-en-002.EPS

Selection aid for online processes

Process	Path	Dosing actuators	Required hardware equipment for control				Ordering variants CPM 153-
			Circuits	Relay	Current inputs	Current outputs	
2-sided control	looking-ahead · 2-circuit · flow	2 PWM	2	2	1	-	x3x2xxxxx
		2 PFM	2	2	1	-	x3x2xxxxx
		1 three-PS	2	3	2	-	x3x4xxxxx
		1 PWM/PFM					
		current output split range	2	-	1	1	x3x2xxxxx
	not looking-ahead	2 PWM	1	2	-	-	x1x0xxxxx
		2 PFM	1	2	-	-	x1x0xxxxx
		1 three-PS	1	3	1	-	x1x2xxxxx
		1 PWM/PFM					
		current output split range	1	-	-	1	x1x0xxxxx

C07-CPM153xx-16-12-00-en-001.EPS

Selection aid for batch processes

Process	Dosing actuators	Required hardware equipment for control				Ordering variants CPM 153-	
		Circuits	Relay	Current inputs	Current outputs		
1-sided control	1 PWM	1	1	–	–	x1x0xxxxx	
	1 PFM	1	1	–	–	x1x0xxxxx	
	1 three-PS 1 PWM/PFM	with signal	1	2	1	–	x1x2xxxxx
		without signal	1	2	–	–	x1x0xxxxx
	current output	1	–	–	1	x1x0xxxxx	
2-sided control	2 PWM	1	2	–	–	x1x0xxxxx	
	2 PFM	1	2	–	–	x1x0xxxxx	
	1 three-PS 1 PWM/PFM	with signal	1	–	1	1	x1x0xxxxx
		without signal	1	3	–	–	x1x2xxxxx
	current output split range	1	3	–	–	x1x0xxxxx	

C07-CPM153xx-16-12-00-en-003.EPS

DAT module

The DAT module is a memory device (EEPROM) which is plugged into the terminal compartment of the transmitter. Using the DAT module, you can

- save complete settings, logbooks and the logged data of the data loggers of the CPM 153 and
- copy the complete settings to other CPM 153 transmitters which have identical hardware functionality.

This considerably reduces the effort to install or service several measuring points.

Offline configuration (Accessories)

Using the PC tool, you can:

- ① Configure the whole measuring point on the PC in the familiar Windows environment and
 - ② Save the settings to the DAT module.
 - ③ Install the DAT module in a Mycom S and transfer the entire configuration to the transmitter (= complete transmitter set-up).
- Then you can set up other transmitters with the same configuration.
- ④ Similarly, you can use the DAT to copy logbooks and data loggers from the transmitter for documentation purposes and save them to your computer. You can then display the logged data in graphic form on your PC.

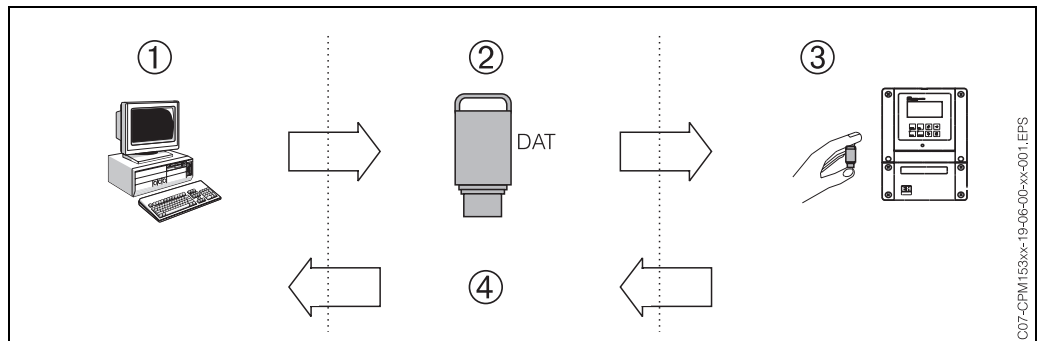

C07-CPM153xx-19-06-00-xx-001.EPS

Refer to the graphic on page 17 for information on the PC tool user interface.

Calibration

Accurate calibration and measurement

The instrument allows all field-tested calibration possibilities including isothermic intersection compensation:

- Automatic calibration through buffer self-recognition
The buffer tables, e.g. to DIN, Endress+Hauser, Merck and Riedel de Haën/ Ingold, are saved in the instrument. Further buffer tables can also be programmed. During calibration, the instrument automatically recognises the buffer value.
- Manual calibration
When calibrating manually, you can conduct either a two-point calibration (zero point and slope) or a single-point calibration, i.e. zero point calibration of the pH electrode.
- Numeric calibration (data input)
The electrode data (zero point and slope) are entered using the keypad.
- Calibration logbook
The data of the last 30 calibrations are saved to a list with date and time.
- Medium temperature compensation (alpha value compensation)
This allows high-accuracy measurement over wide temperature ranges. In this type of compensation, the temperature influence on the medium is self-compensated.



Input



Note!



The limit values for Ex version are specified separately and displayed in *italics*.



Measured variables	pH, redox, temperature	
pH	Measuring range	-2.00 ... +16.00
	Measured value resolution	pH 0.01
	Zero point offset range	pH -2 ... +16
	Range of automatic temperature compensation	-50 ... +150°C
	Reference temperature	25°C (settable with medium temperature compensation)
	Slope adjustment	25 ... 65 mV / pH
	Input resistance under nominal operating conditions	$> 1 \cdot 10^{12} \Omega$
	Input current under nominal operating conditions	$< 1.6 \cdot 10^{-12} \text{ A}$
	: Certification pending.	
Redox	Measuring range	-1500 ... +1500 mV -3000 ... +3000%
	Measured value resolution	0.1 mV
	Zero point offset range	+200 ... -200 mV
	Assignment with % display	Settable, Δ for 100% = 150 ... 2000 mV
	Electrode offset	$\pm 120 \text{ mV}$
	Input resistance under nominal operating conditions	$> 1 \cdot 10^{12} \Omega$
	Input current under nominal operating conditions	$< 1.6 \cdot 10^{-12} \text{ A}$
		: Certification pending.

Temperature	Temperature sensor	Pt 100 (three-wire circuit) Pt 1000 NTC 30 PTC
	Measuring range (can also be displayed in °F)	-50 ... +200°C
	Measured value resolution  : Certification pending.	0.1 K
Current inputs 1 / 2 (passive, optional)	Signal range	4 ... 20 mA
	Measured error ¹	max. 1% of measuring range
	Input voltage range  : Certification pending.	6 ... 30 V
Resistance input (active, optional, only with non-Ex)	Resistance ranges (switchable using software)	0 ... 1 kΩ 0 ... 10 kΩ
	Measured error ¹	max. 1% of measuring range
Digital inputs	Input voltage	10 ... 50 V
	Internal resistance  : Certification pending.	R _i = 5 kΩ

¹: acc. to IEC 746-1, under nominal operating conditions

Output parameters

Output signal	pH, redox, temperature	
Current outputs	Current range	0 / 4 ... 20 mA
	Error current	2.4 mA or 22 mA
	Measured error ¹	current range end value
	Output distribution, settable	pH: 1.8 ... 18 pH Redox: 300 ... 3000 mV Temperature: 17 ... 170°C
	Active current output (only non-Ex): Load	max. 600 Ω
	Passive current output: Input voltage range  : Certification pending.	6 ... 30 V
Auxiliary voltage output (for digital inputs E1-E3)	Voltage	15 V DC
	Output current  : Certification pending.	max. 9 mA
Interface to CPC 30 / 300	Power supply: Output voltage	11.5 ... 18 V

	Output current	max. 60 mA
	Communication	RS 485
	 : Certification pending.	
Limit value and alarm functions	Setpoint adjustments	pH -2.00 ... 16.00
	Hysteresis for switch contacts	pH: 0.1 ... 18 Redox absolute: 10 ... 100 mV Redox relative: 1 ... 3000%
	Error delay	0 ... 6000 s
	 : Certification pending.	

Relay contacts

The NC/NO contact type can be set by software.	
Switching voltage	max. 250 V AC / 125 V DC
Switching current	max. 3 A
Switching power	max. 750 VA
Life span	≥ 5 million switching cycles
With the maximum settable frequency in PFM	120 min ⁻¹
With the maximum settable period length in PWM	1 ... 999.9s
With PWM minimum switch-on period	0.4 s

¹: acc. to IEC 746-1, under nominal operating conditions

Galvanic isolation

At the same potential are:

- Current output 1 and the power supply
- Current output 2, CPC and the resistance input.

The remaining circuits are galvanically isolated from each other.

Electrical connection

Connection diagram for Ex and non-Ex ranges

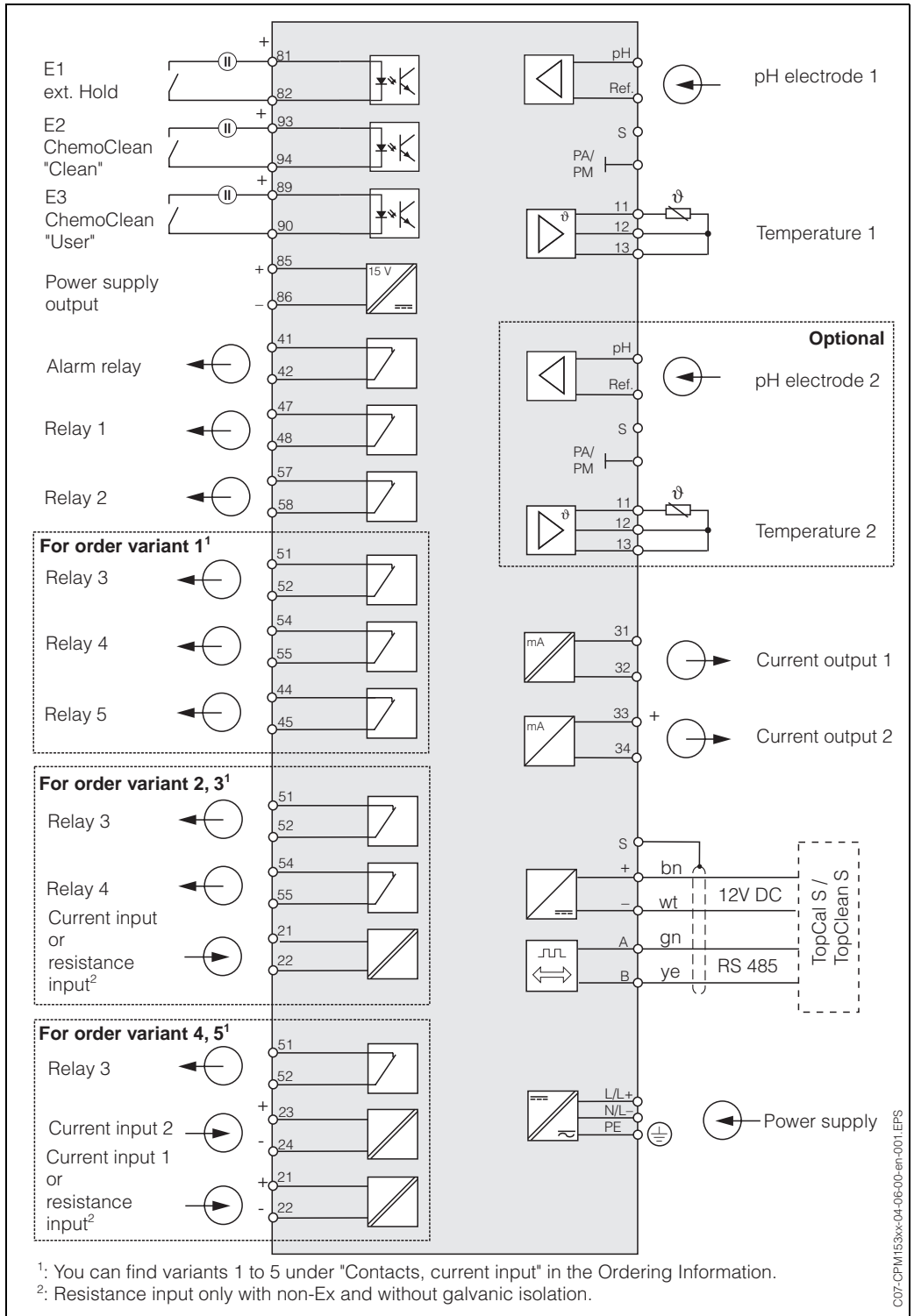

C07-CPM153xx-04-06-00-en-001.EPS

Switching example for digital inputs

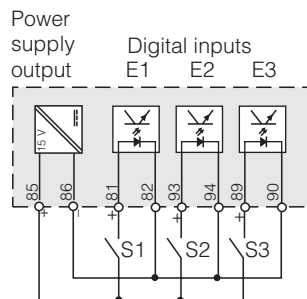

E1: External Hold
 E2: ChemoClean "Clean"
 E2: ChemoClean "User"
 S1, S2, S3: external de-energise contacts

C07-CPM153xx-04-06-00-en-005.EPS

Contacts

In the basic version, the Mycom S CPM 153 possesses 1 alarm and 2 additional contacts. The instrument can be upgraded with the following **additional** equipment:

- 3 contacts
- 2 contacts and 1 current or resistance input (only for non-Ex)
- 1 contact, 1 current input and 1 current or resistance input (only for non-Ex)

The available contacts can be assigned with the software.



The **ChemoClean**[®] spray cleaning system with the CYR 10 injector automatically cleans the electrode. It is controlled by two contacts (also part of basic equipment).

The NC/NO contact type can be switched by software.



Note!

- If you use NAMUR contacts (acc. to recommendations of the community of interest process control engineering of the chemical and pharmaceutical industry), the contacts are set to the relays as follows:
 - Failure to "ALARM"
 - Maintenance required to "RELAY 1" and
 - Function control to "RELAY 2".

Selection by software	NAMUR	on
ALARM 41  42	Alarm	
RELAY 1 47  48	Warning when maintenance required	
RELAY 2 57  58	Function control	

- You can assign up to three relays to the controller.

Electrical connection data

Power supply for CPM 153-xxxx 0 xxxx	100 ... 230 V AC +10/-15%
Frequency	47 ... 64 Hz
Power supply for CPM 153-xxxx 8 xxxx	24 V AC/DC +20/-15%
Power consumption	max. 10 VA
Separation voltage between galvanically isolated circuits	276 V _{rms}
Terminals, max. cable cross-sectional area	2.5 mm ²

Connection examples

Non-Ex: One-circuit instrument, NAMUR contact assignment, Chemoclean with CYR 10 injector and assembly with spray head, one-sided neutralisation, temperature limit value, pH current output

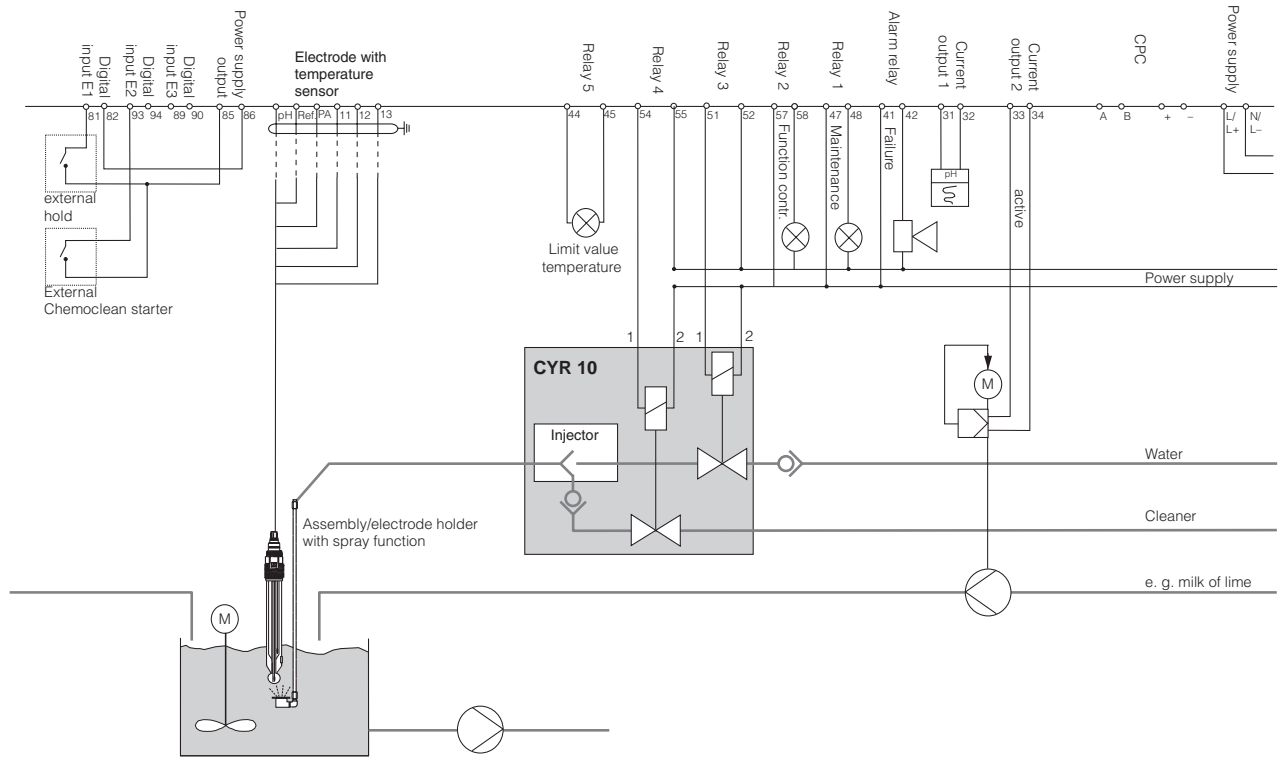

C07-CPM153xx-04-06-00-en-002 EPS

Non-Ex: Two-circuit difference measurement, pH and delta pH on current outputs, limit values for Δ pH, temperature circuit 1

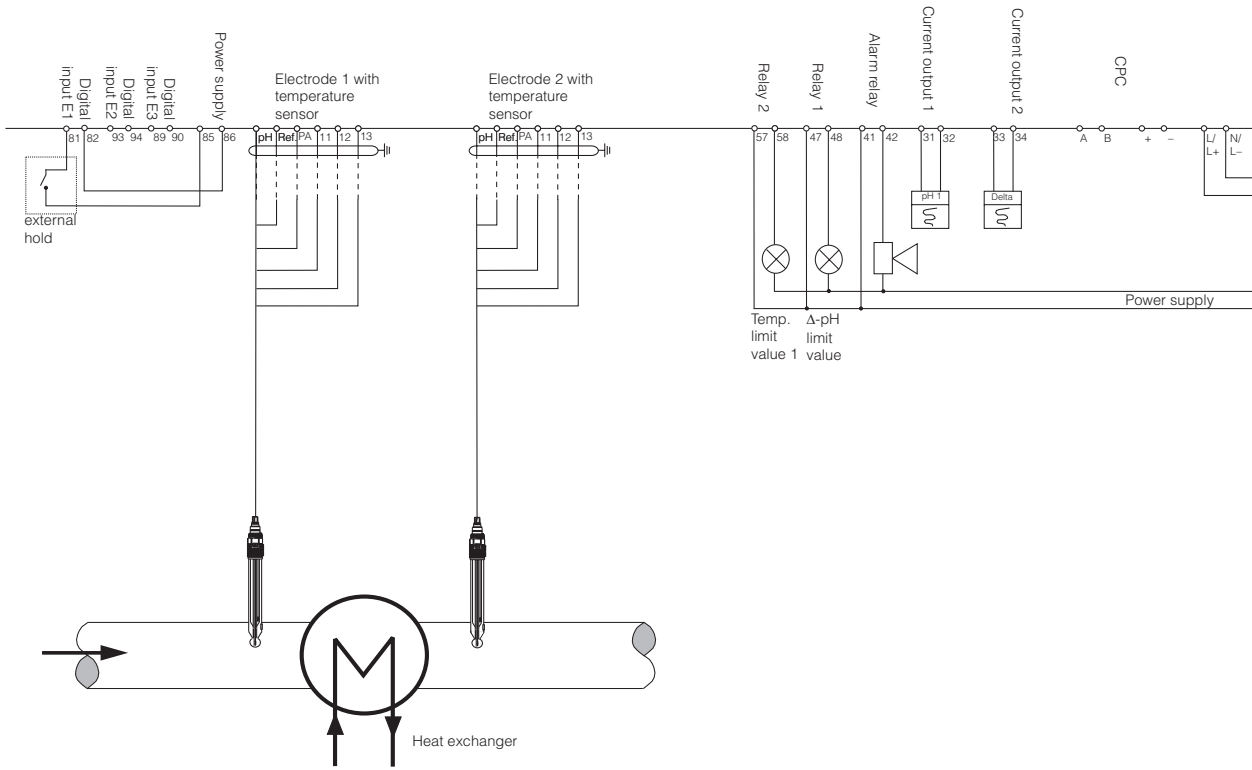

C07-CPM153xx-04-06-00-en-003.EPS

Ex: One-circuit instrument, NAMUR, Chemoclean with CYR 10 Z injector and assembly with spray head, milk-of-lime neutralisation, temperature limit value, pH current output

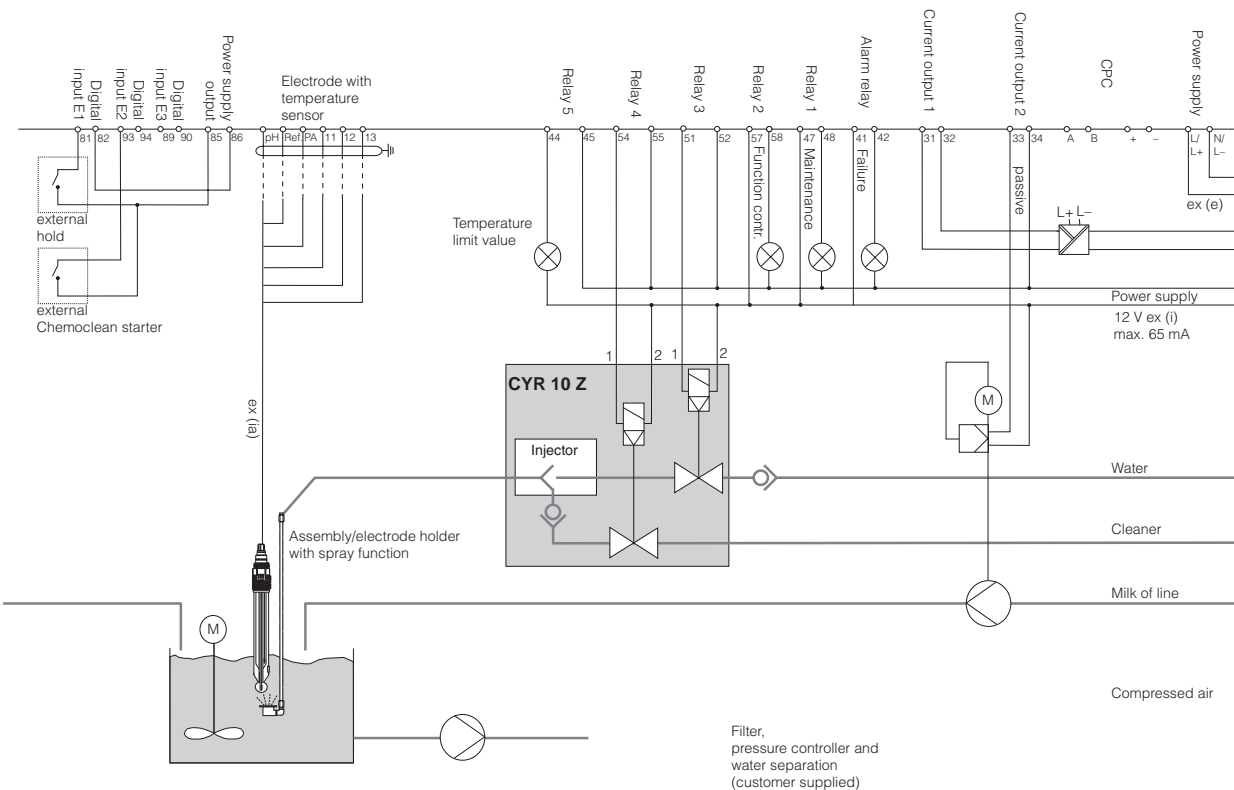

C07-CPM153xZ-04-06-00-en-002.EPS

Ex: Two-circuit difference measurement, pH and delta pH on current outputs, limit values for Δ -pH, temperature.circuit 1

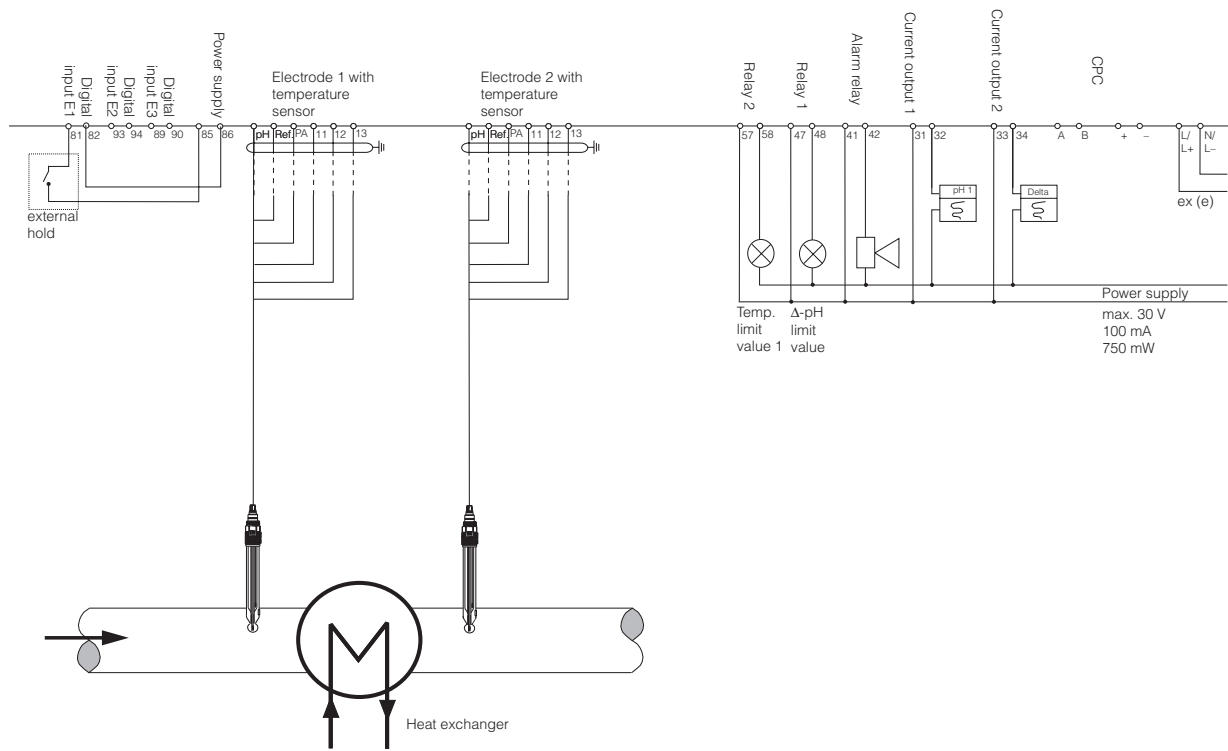

C07-CPM153x2-04-06-00-en-003.EPS

Accuracy

Measured value resolution	pH:	0.01
	Redox:	1 mV / 1%
	Temperature:	0.1 K
Measurement deviation¹ display	pH:	max. 0.2% of measuring range
	Redox:	1 mV
	Temperature:	max. 0.5 K
Measured error¹	max. 0.2% of current range end value	
Repeatability¹	max. 0.1% of measuring range	

¹: acc. to IEC 746-1, under nominal operating conditions

Operating conditions

Installation instructions

- The Mycom S CPM 153 transmitter can be fixed to vertical or horizontal posts using the round post fixture available from Endress + Hauser (see "Accessories"). When installing the instrument outdoors, you also require the CYY 101 weather protection cover. This cover is compatible with all field instrument installations options.
- Always install the transmitter so that the cable entries point downwards.

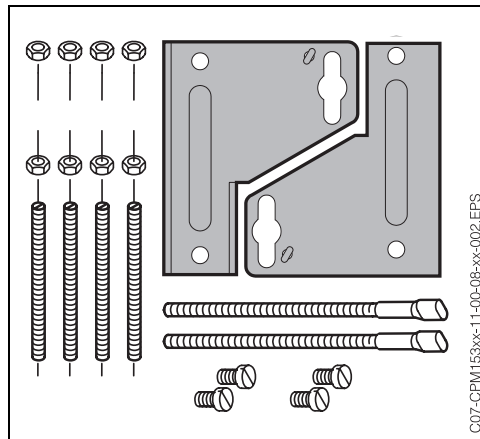

Post fixture is possible using the enclosed mounting kit (see left).

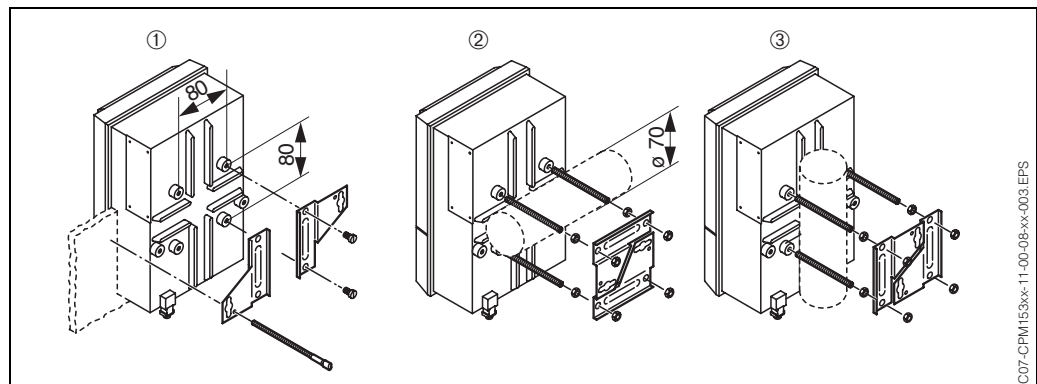

Panel mounting ① and post mounting ② for Mycom S CPM 153

Required installation cutout for panel mounting:

The installation depth is

The maximum post diameter is

$161^{+0.5} \times 241^{+0.5}$ mm.

approx. 134 mm.

70 mm

For outdoor use, the CYY 101 weather protection cover is required. This is available as an accessory.

Ambient conditions

Ambient temperature -10 ... +55°C (Ex: -10 ... +50°C)

Ambient temperature limit -20 ... +60°C (Ex: -10 ... +50°C)

Storage and transport temperature -30 ... +80°C

Relative humidity 10 ... 95%, non-condensing

Ingress protection IP 65

Electromagnetic compatibility

Interference emission and interference immunity to EN 61326: 1997 / A1:1998

Mechanical construction

Design / dimensions

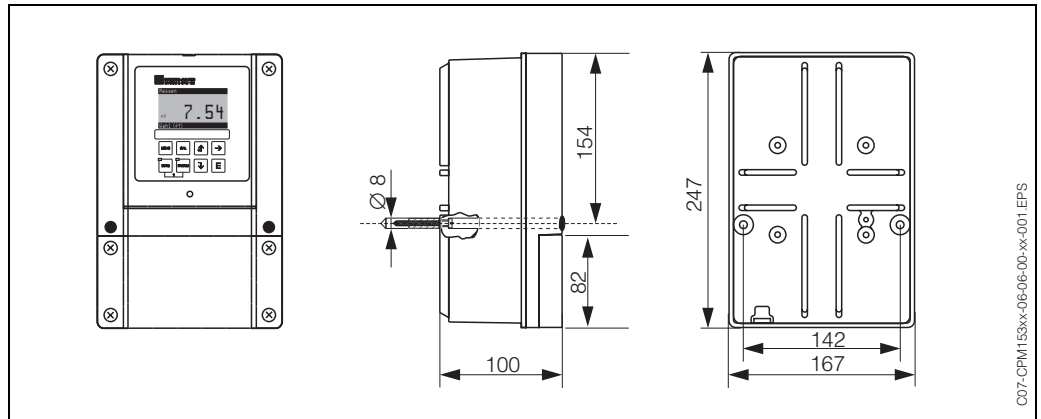

Measuring transmitter dimensions Mycom S CPM 153.

Weight

max. 6 kg

Materials

Housing GD-AISI 12 (Mg content 0.05%), plastic-coated
 Front Polyester, UV-resistant

Display and operating interface

To configure the whole measuring point, you can either use the keypad on the transmitter Mycom S CPM 153 or the offline configuration. If you are using several instruments, the complete configuration of one instrument can be copied to other instruments using the DAT module.

Display elements

Backlit LC display with dot matrix, 128 x 64 dots

Display possibilities:

One circuit instrument:

pH/redox value, temperature, current outputs 1 and 2, contact states, control parameters (setpoint, set value)

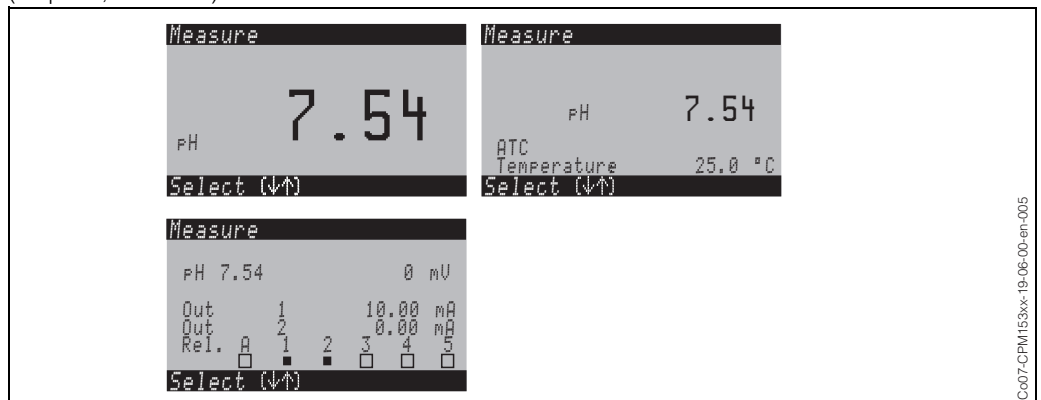

Two-circuit instrument:

pH/redox value 1 and 2, temperature 1 and 2, current outputs 1 and 2, contact states, difference between the pH/redox values, control parameters (setpoint, set value)

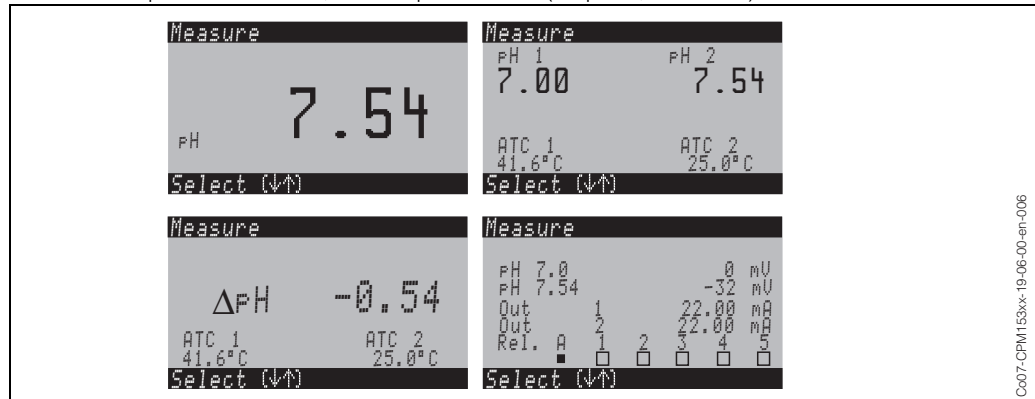

C07-CPM153xx-19-06-00-en-006

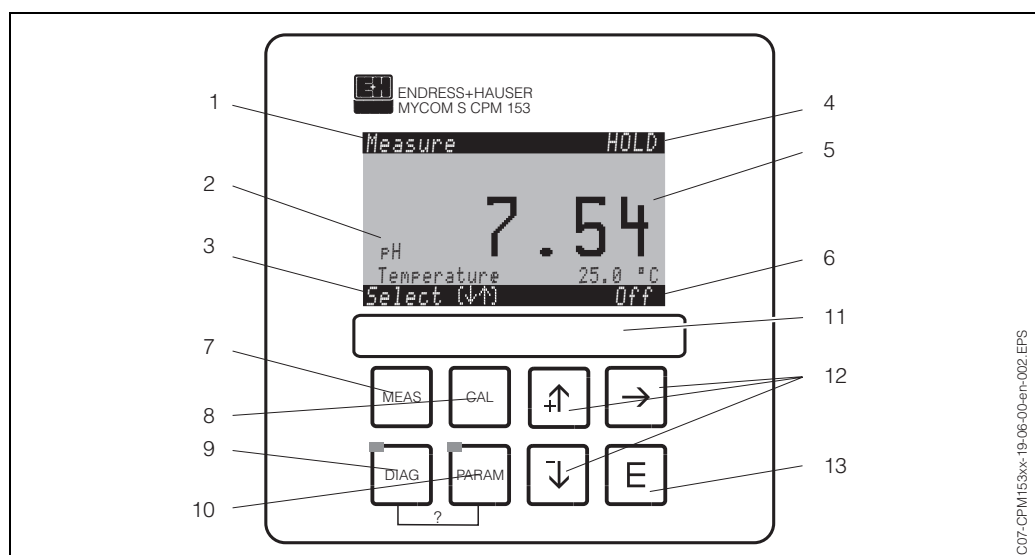

C07-CPM153xx-19-06-00-en-002-EPS

Mycom S CPM 153 user interface

- 1: Current menu
- 2: Current parameter
- 3: Navigations bar: Arrow keys for scrolling, "E" for browsing, Note for Cancel
- 4: HOLD display, if HOLD active
- 5: Current main measured value
- 6: "Failure" display, "Warning", if the NAMUR contacts respond
- 7: "Meas" (Measuring mode) key

- 8: "Cal" (Calibration) key
- 9: "Diag" (Diagnosis menu) key
- 10: "Param" (Parameter entry menu) key
- ?: Press DIAG and PARAM simultaneously to open the help pages
- 11: Labelling strip
- 12: Arrow keys for scrolling and editing
- 13: ENTER key

Operating elements

There are 4 main menus available for instrument operation:

- Measurement ("MEAS")
- Configuration ("PARAM")
- Calibration ("CAL") and
- Diagnostics ("DIAG").

Press the "MEAS", "PARAM", "CAL" and "DIAG" keys to switch to the appropriate selection menu. The submenus are then displayed in plain text and the selected elements are displayed in reverse video. Selections are made using the arrow keys, which are also used to edit the numeric values.

Access codes

To protect the transmitter against an unintended or undesired modification of the configuration and the calibration data, functions can be protected using four-digit access codes. Function enabling is divided into:

Display level (accessible without a code):

The complete menu can be viewed. The configuration cannot be changed. No calibration is possible. On this level, only the controller parameters for new processes can be changed in the "DIAG" menu branch.

Maintenance level (can be protected with the maintenance code):

This code permits calibration.

Use this code to operate the temperature compensation menu command. The test functions and the internal data can be viewed.

Specialist level (can be protected using the specialist code):

All menus are accessible.

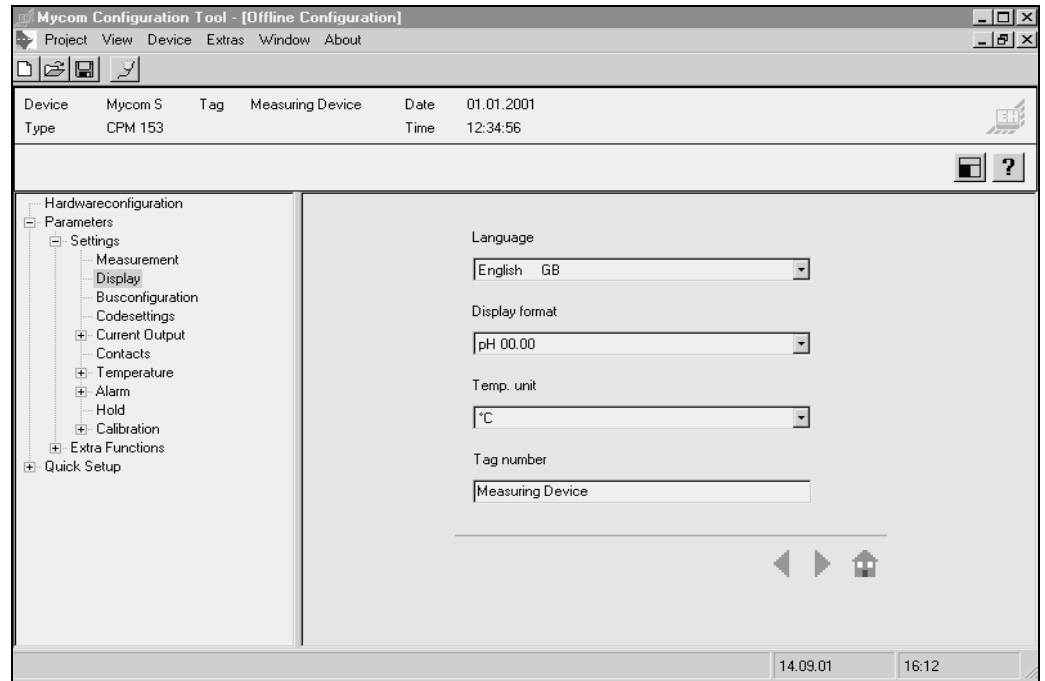
Offline configuration user interface (Accessories)

The PC tool provides you with a tool for configuring your measuring point on a PC using a simple and self-explanatory menu structure (an example window can be seen above). Write the configuration to the DAT module using the RS232 interface on the PC. The module can then be plugged into the transmitter.

Certificates and approvals

CE symbol

The transmitter complies with the legal demands of the harmonized European standards. Endress+Hauser certifies the compliance with the standards by using the **CE** sign.

Ex approval

Atex II (1) 2 G EEx em [ia/ib] IIC T4

Ordering information

Measuring transmitter product structure Mycom S

pH/redox transmitter in aluminium housing for wall mounting with one alarm and two output contacts for NAMUR, ChemoClean, and controller functions as well as three binary inputs, logbooks, data logger. Plain text operation. 247x167x111 mm (HxWxD). Degree of protection IP 65.

Approvals											
										A	Basic equipment: non-Ex
										G	With ATEX approval, ATEX II (1) 2G EEx em ib[ia] IIC T4
										S	With CSA approval; NI Cl. I, Div. 2, Sensor IS Cl. I, Div. 1
										O	With FM approval; NI Cl. I, Div. 2, Sensor IS Cl. I, Div. 1
										P	With FM approval; NI Cl. I, Div. 2
										T	With TIIS approval
Measurement input											
										1	1 measuring circuit for glass electrodes pH/redox and temperature
										2	1 measuring circuits for glass electrodes / IsFET sensors pH/redox and temperature
										3	2 measuring circuits for glass electrodes pH/redox and temperature
										4	2 measuring circuits for glass electrodes / IsFET sensors pH/redox and temperature
Measurement output											
										A	2 current outputs 0/4 ... 20 mA, passive (Ex and non-Ex)
										B	2 current outputs 0/4 ... 20 mA, active (non-Ex)
										C	HART with 2 current outputs 0/4 ... 20 mA, passive (Ex and non-Ex)
										D	HART with 2 current outputs 0/4 ... 20 mA, active (non-Ex)
										E	Profibus-PA, without current outputs
										F	Profibus-DP, without current outputs (non-Ex)
Contacts, current input											
										0	Without additional contacts
										1	Three additional contacts
										2	2 additional contacts, 1 passive current input (Ex and non-Ex)
										3	2 additional contacts, 1 resistance input (non-Ex)
										4	1 additional contact, 1, 2 passive current inputs (Ex and non-Ex)
										5	1 extra contact, 1 passive current input, 1 active resistance input (non-Ex)
Power supply											
										0	100 ... 230 V AC
										8	24 V AC / DC
Language versions											
										A	D / E / F / I / ES
										B	D / E / NL / J
Cable connection											
										0	Cable glands M 20 x 1.5
										1	Adapter for cable gland NPT ½"
										2	Adapter for cable gland G ½
Additional equipment											
										0	Without additional equipment
										1	Additional equipment: DAT module
Configuration											
										0	Factory settings
CPM 153-											Complete order code

Accessories

Offline configuration	The PC tool provides you with a tool for configuring your measuring point at the PC using a simple and self-explanatory menu structure. Write the configuration to the DAT module using the RS232 interface on the PC. The module can then be plugged into the transmitter. The offline configuration system consists of a DAT module, the software and a DAT interface (RS 232). Order No.: 51507133
DAT module	Additional memory device for <i>saving/copying</i> complete settings, logbooks and the data loggers. Order No.: 51507175
pH/redox combination electrodes	OrbiSint W CPS 11/12 gel electrode CeraGel P CPS 71 gel electrode with double-chamber reference system CeraLiquid P CPS 41/42 liquid KCl electrode (with SSA or ESS head)
Assemblies	Immersion assembly, e.g. DipFit P CPA 140 Flow assembly, e.g. FlowFit P CPA 240 Retractable assembly, e.g. CleanFit H CPA 475
pH measuring cable	e.g. pH measuring cable CPK 9 (for high temperature applications, IP 68 / NEMA 6X, also for explosion hazardous areas)
Weather protection cover CYY 101	For outdoor installation, the CYY 101 weather protection cover is required. Order No.: CYY101-A
Round post fixture for weather protection cover	To fix the weather protection cover to vertical or horizontal posts with diameters of up to 70 mm. Order No.: 50062121

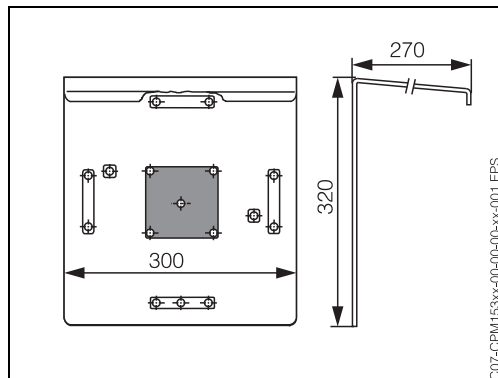

Weather protection cover CYY 101

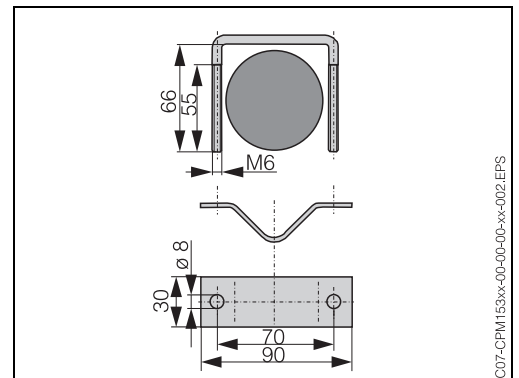

Round post fixture for CYY 101

Documentation

Documentation

- Technical Information TopCal S CPC 300, TI 236C/07 (Order No. 51504330)
- Technical Information TopClean S CPC 30, TI 235C/07 (Order No. 51504335)
- Technical Information CleanFit H CPA 475, TI 240C/07/ (Order No. 51505599)
- Technical Information OrbiSint W CPS 11/12/13, TI 028C/07 (Order No. 50054649)
- Technical Information CeraLiquid P CPS 41/42/43, TI 079C/07 (Order No. 50059346)
- Technical Information CeraGel P CPS 71, TI 245C/07 (Order No. 51505837)
- Technical Information CPK 1-9, TI 118C/07 (Order No. 50068526)

Subject to modifications

Endress+Hauser
GmbH+Co.
Instruments International
P.O. Box 2222
D-79574 Weil am Rhein
Germany

Tel. +49 (0)7621 975-02
Fax +49 (0)7621 975-345
<http://www.endress.com>
info@ii.endress.com

Endress + Hauser
The Power of Know How

