

HART

Field Communication with

Mycom S CXM 153

TopCal S CPC 300

TopClean S CPC 30

Operating Instructions

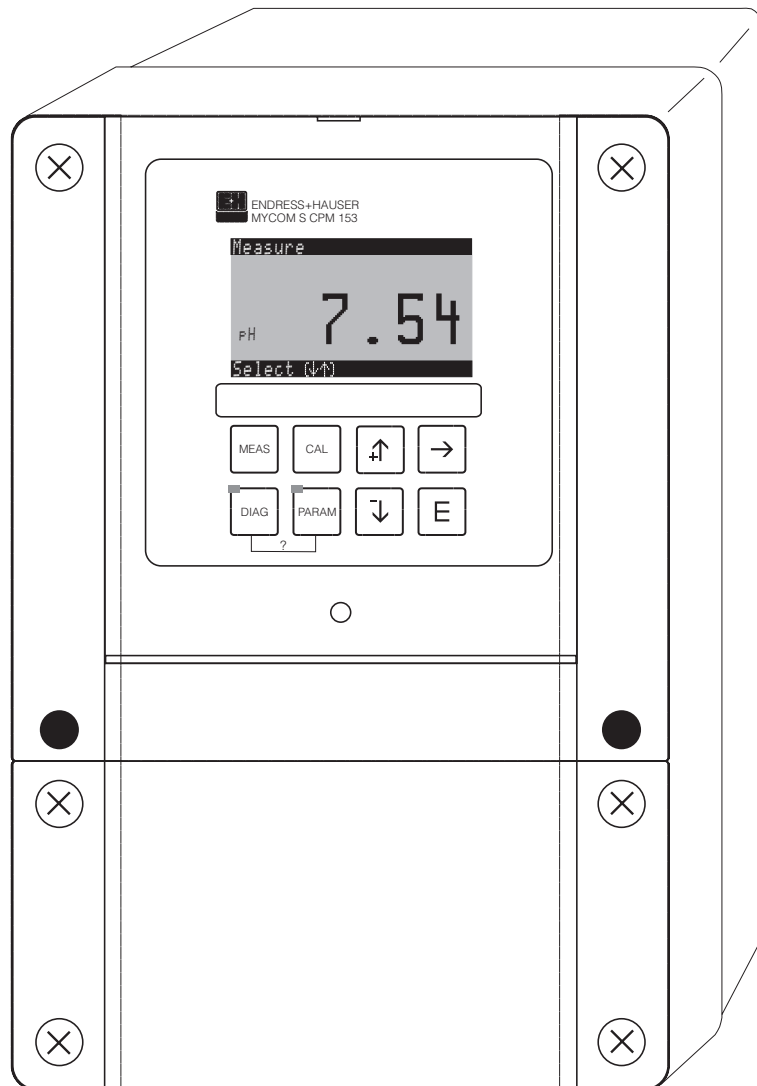

Quality made by
Endress+Hauser



ISO 9001

Endress + Hauser

The Power of Know How



Table of contents

1	Safety instructions	4	5.2	Operation via the HART® handheld terminal DXR 275	12
1.1	Notes on safety conventions and icons	4	5.3	Operation via Commuwin II	13
1.2	Designated use	5	5.4	HART® commands	15
1.3	Installation, commissioning and operation	5	6	Commissioning	21
1.4	Operational safety	5	6.1	Function check	21
2	Identification	6	6.2	Setting the device address	21
2.1	Device designation	6	7	Maintenance	22
2.2	Scope of delivery	6	8	Troubleshooting	23
2.3	Certificates and approvals	6	8.1	Device status / error messages	23
3	Installation	7	9	Accessories	32
3.1	System architecture	7	10	Technical data	33
3.2	Post-installation check	7	10.1	Output	33
4	Electrical connection	8	10.2	Electrical connection	33
4.1	Quick connection guide	8	10.3	Human interface	33
4.2	Connecting the HART® handheld terminal DXR 275	9	10.4	Documentation	33
4.3	Connecting a PC with operating programme	10	11	Index	34
4.4	Post-connection check	11			
5	Operation	12			
5.1	Display and operating elements	12			

1 Safety instructions

1.1 Notes on safety conventions and icons

General safety instructions



Warning!

This symbol alerts you to hazards which could cause serious injuries as well as damage to the instrument if ignored.



Caution!

This symbol alerts you to possible faults which could arise from incorrect operation. They could cause damage to the instrument if ignored.



Note!

This symbol indicates important items of information.

Electrical symbols



DC voltage

A terminal at which DC voltage is applied or through which DC flows.



AC voltage

A terminal at which (sine-form) AC voltage is applied or through which AC flows.



Ground connection

A grounded terminal, which, from the user's point of view, is already grounded using a ground system.



Protective earth terminal

A terminal which must be grounded before other connections may be set up.



Equipotential connection

A connection which must be connected to the grounding system of the equipment. This can be, for example, a potential matching line of a star-shaped grounding system, depending on national or company practice.



Double insulation

The equipment is protected with double insulation.

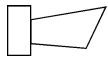

Alarm relay



Input

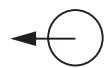

Output

1.2 Designated use

The transmitter Mycom S CXM 153 HART® is a device for measuring the pH value or the redox potential or the conductivity. The HART® interface allows the device to be operated via the handheld terminal DXR 275 or, using the operating programme Commuwin II, at a PC by means of a HART® modem, e.g. Commubox FXA 191.

Any other use than the one described here compromises the safety of persons and the entire measuring system and is therefore not permitted.

The manufacturer is not liable for damage caused by improper or non-designated use.

1.3 Installation, Commissioning, Operation

Please note the following items:

- Installation, electrical connection, commissioning, operation and maintenance of the measuring system must only be carried out by trained technical personnel. The technical personnel must be authorised for the specified activities by the system operator.
- Technical personnel must have read and understood these Operating Instructions and must adhere to them.
- Before commissioning the entire measuring point, check all the connections for correctness. Ensure that electrical cables and hose connections are not damaged.
- Do not operate damaged products and secure them against unintentional commissioning.
- Measuring point faults may only be rectified by authorised and specially trained personnel.
- If faults can not be rectified, the products must be moved from service and secured against unintentional commissioning.
- Repairs not described in these Operating Instructions may only be carried out at the manufacturer's or by the Endress+Hauser service organisation.

1.4 Operational safety

The transmitter has been designed and tested according to the state of the art and left the factory in perfect functioning order.

Relevant regulations and European standards have been met.

As the user, you are responsible for complying with the following safety conditions:

- Explosion protection regulations
- Installation instructions
- Local standards and regulations

In addition, the separate Ex-documentation also applies to Ex-systems. This forms a part of these Operating Instructions.

2 Identification

2.1 Device designation

2.1.1 Nameplate

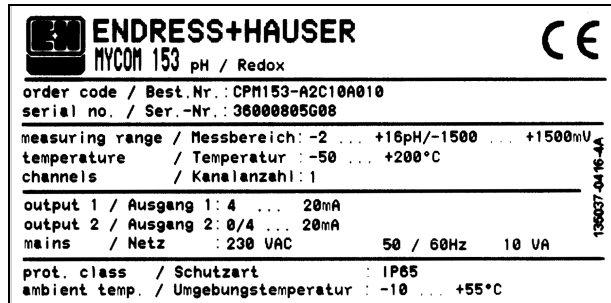

Fig. 1: Example of a nameplate of the Mycom S CXM 153 transmitter with HART® communication.

Identify your device using the product structure in the standard Operating Instructions for the device, (s. chap. 2.2).

2.2 Scope of delivery

Check the scope of delivery using your order and the delivery documents for:

- Completeness
- Instrument type and version acc. to the nameplate, (s. chap. 2.1.1)
- Accessories, (s. chap. 9)
- Standard Operating Instructions BA 233C/07/en or BA 234C/07/en
- HART® Operating Instructions BA 301C/07/en
- For Ex systems also the Ex Operating Instructions XA 233C/07/a3
- Instrument identification card

2.3 Certificates and approvals

Declaration of conformity

The transmitter complies with the legal demands of the harmonized European standards. Endress+Hauser certifies the compliance with the standards by using the CE mark.

3 Installation

3.1 System architecture

The complete system consists of the following components:

- Transmitter Mycom S CXM 153 (1)
- HART® handheld terminal DXR 275 (2)
- HART® modem Commubox FXA 191 (3)
- PC with operating programme Commuwin II (4)
- Recorder (5)

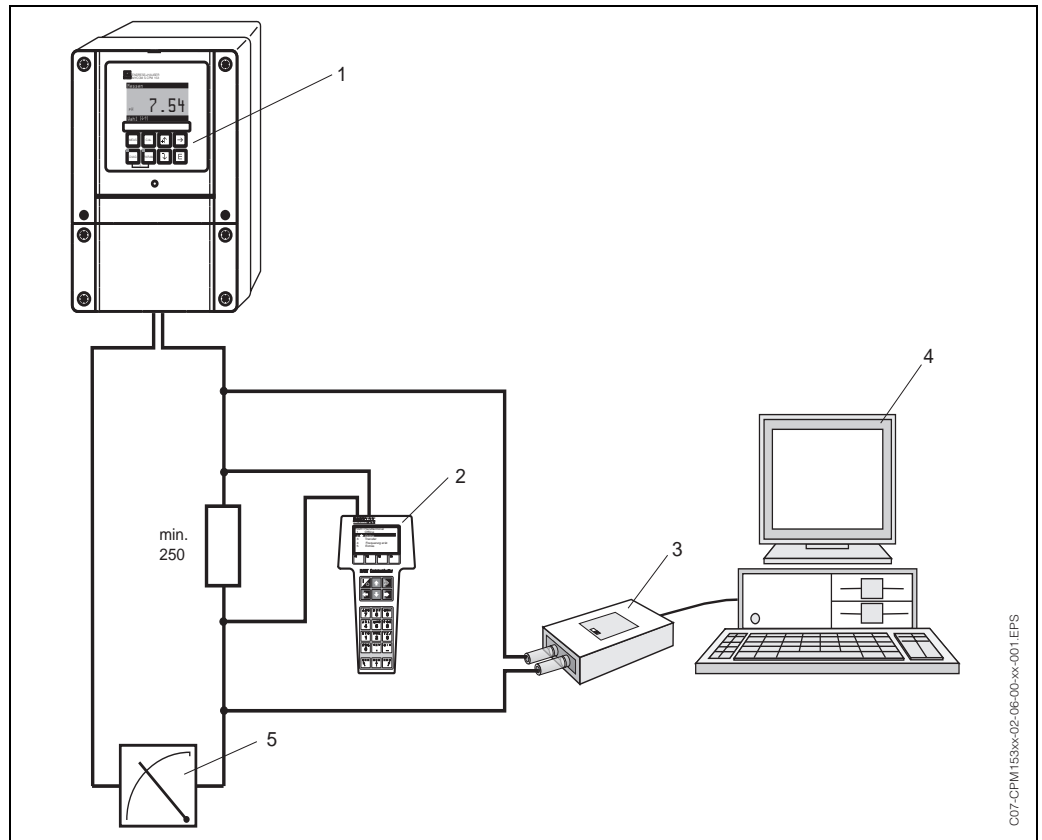

Fig. 2: System architecture Mycom S CXM 153 HART®

3.2 Post-installation check

After installing the transmitter, carry out the following checks:

Instrument status and specifications	Note
Is the transmitter damaged?	Visual inspection
Installation	Note
Are the measuring point number and the labelling correct?	Visual inspection
Process environment/conditions	Note
Is the transmitter protected against rainfall and direct sunlight?	For outdoor installation, the weather protection cover CYY 101 is required, (see Accessories).

4 Electrical connection

4.1 Quick connection guide

4.1.1 Wiring diagram

Users have the following connection options at their disposal:

- Direct connection to the transmitter by means of current output 1 (terminals 31 / 32)
- Connection by means of the 4...20 mA circuit.



Note!

- The measuring circuit's minimum load in current output 1 must be at least 250 Ω.
- Current output 1 (Field EA3) is fixed at "4–20 mA" for the HART® device.
- With no external power supply, communication via current output 1 is only possible if the jumper position is "active".

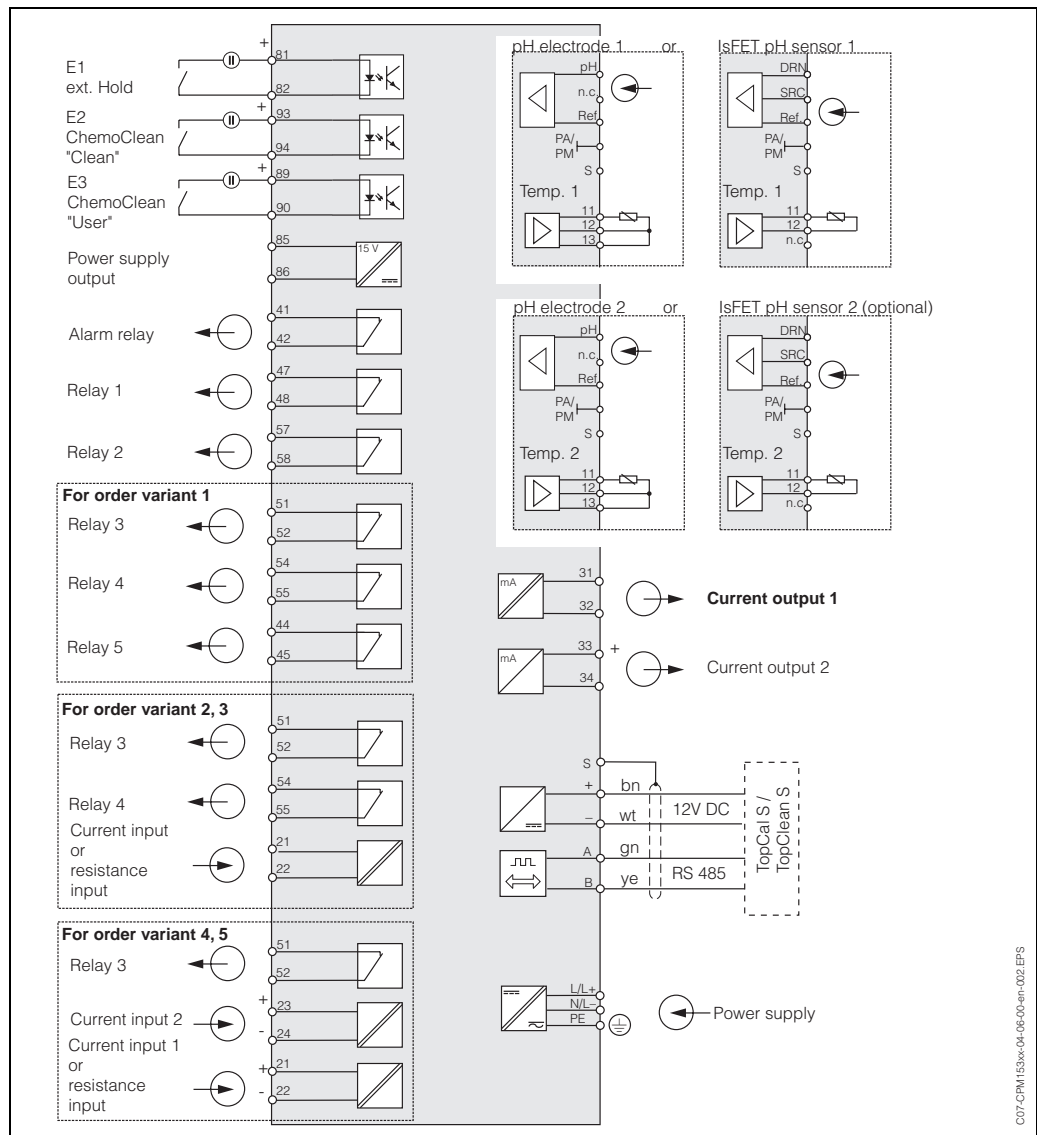

Fig. 3: Electrical connection of Mycom S CXM 153 HART®

4.2 Connecting the HART® handheld terminal DXR 275

You require the HART® handheld terminal DXR 275 for operation using a handheld terminal. The HART® handheld terminal DXR 275 is connected via the current output 1 of the transmitter.

For connecting, please refer also to the documentation issued by the HART® Communication Foundation, and in particular the booklet HCF LIT 20: "HART®, A Technical Overview".

Active current output 1

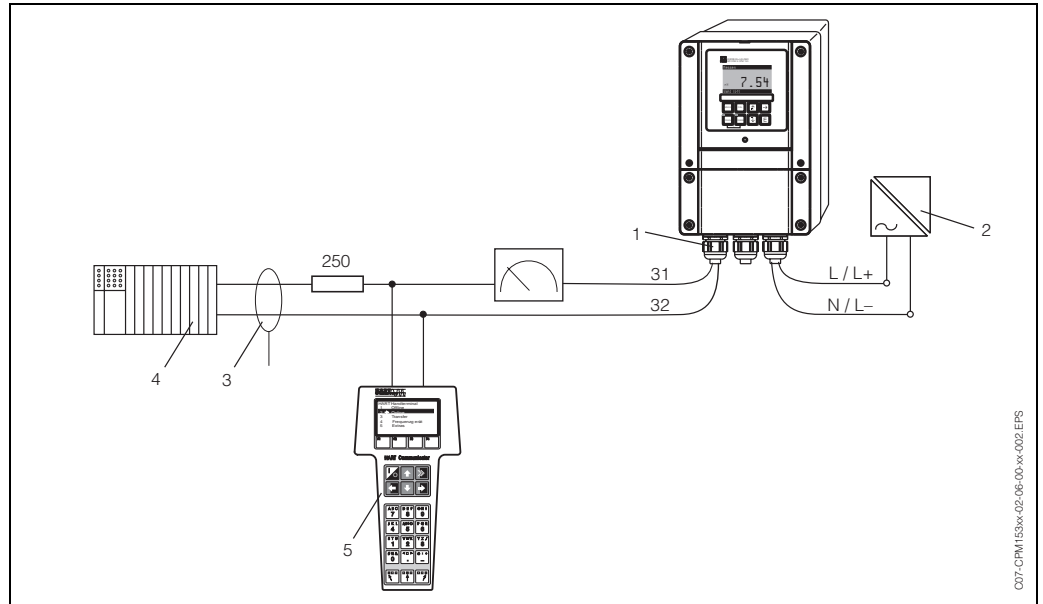

Fig. 4: Electrical connection of the HART® handheld terminal DXR 275
 1 = current output 1 of the transmitter, 2 = power supply, 3 = screening, 4 = other switching units or PLC with passive input, 5 = HART® handheld terminal DXR 275

Passive current output 1

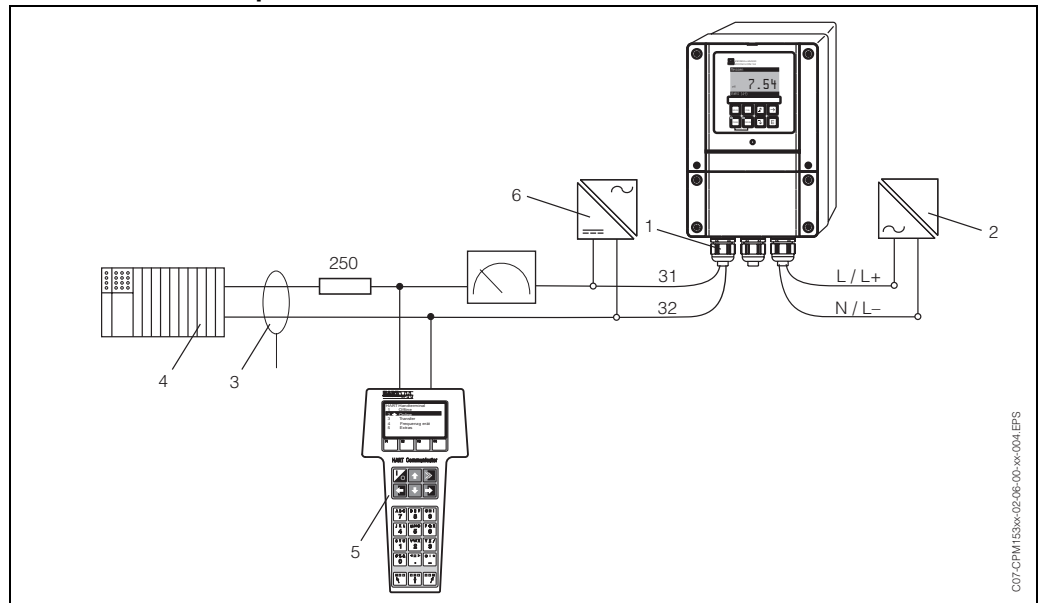

Fig. 5: Electrical connection of the HART® handheld terminal DXR 275
 1 = current output 1 of the transmitter, 2 = power supply, 3 = screening, 4 = other switching units or PLC with passive input, 5 = HART® handheld terminal DXR 275, 6 = power unit 24 V DC

4.3 Connecting a PC with operating programme

You require a HART® modem Commubox FXA 191 for connecting a personal computer with operating programme Commuwin II. The HART® modem Commubox FXA 191 is connected via the current output 1 of the transmitter.

For connecting please refer also to the documentation issued by the HART® Communication Foundation, and in particular the booklet HCF LIT 20: "HART®, A Technical Overview".

Active current output 1

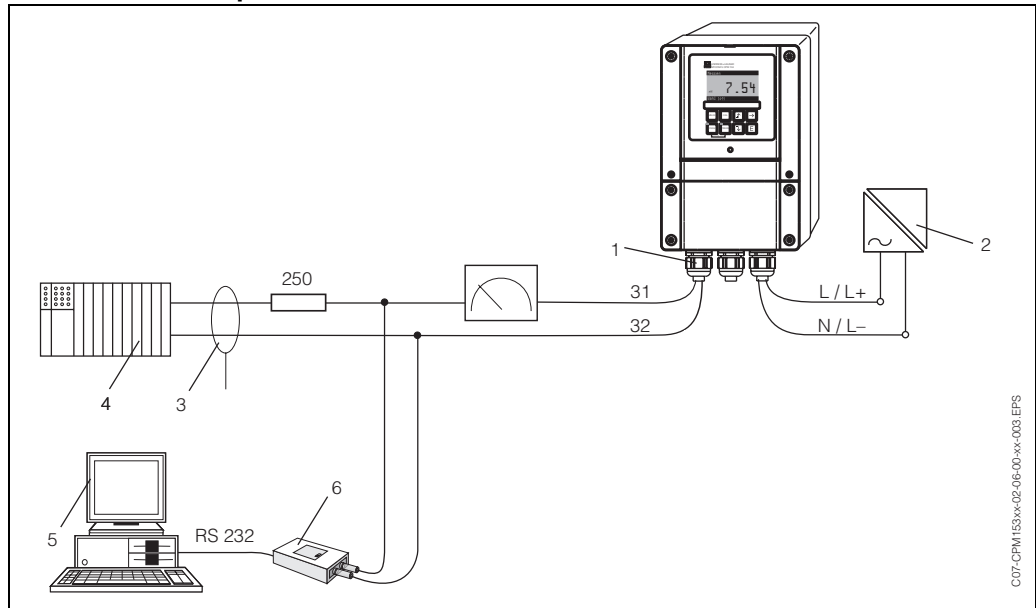

Fig. 6: Electrical connection of the Commubox FXA 191
1 = current output 1 of the transmitter, 2 = power supply, 3 = screening, 4 = other switching units or PLC with passive input, 5 = PC with operating software, 6 = HART® modem Commubox FXA 191

Passive current output 1

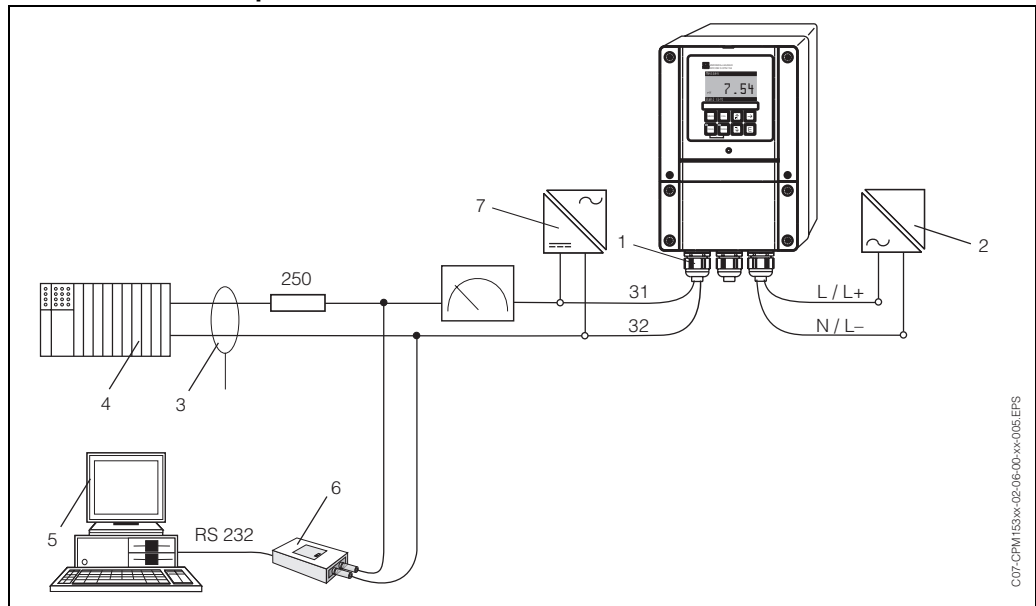

Fig. 7: Electrical connection of the Commubox FXA 191
1 = current output 1 of the transmitter, 2 = power supply, 3 = screening, 4 = other switching units or PLC with passive input, 5 = PC with operating software, 6 = HART® modem Commubox FXA 191, 7 = power unit 24 V DC



Note!

- The Commuwin II and HART® handheld terminal DXR 275 can only be operated simultaneously if:
 - one device is set as the primary master and the other as the secondary master
 - neither master is constantly communicating.

4.4 Post-connection check

After wiring up the electrical connection of the measuring instrument, carry out the following checks:

Instrument status and specifications	Note
Is the measuring instrument or the cable damaged externally?	Visual inspection
Electrical connection	Note
Does the supply voltage match the specifications on the nameplate?	100 V ... 230 V AC long-range 24 V AC / DC
Do the cables used fulfil the required specifications?	Use genuine E+H cables for sensor connection, see Accessories chapter in the standard Operating Instructions
Are the mounted cables strain-relieved?	
Is the cable type route completely isolated?	Along the whole cable length, run the power supply and signal line cables separately to avoid any mutual influence. Cable channels are best.
No loops and cross-overs in the cable run?	
Are the power supply and signal cable correctly connected according to the wiring diagram?	
Are all the screw terminals tightened?	
For connection with potential matching (PML): Is the PML connected to the measuring medium?	 Note! During calibration, insert the PML into the buffer solution.
Are all the cable entries installed, tightened and sealed? Cable run with "water sag"?	"Water sag": cable circuit hanging down so that water can drip off.
Are all the housing covers installed and tightened?	Check seals for damage.

5 Operation

5.1 Display and operating elements

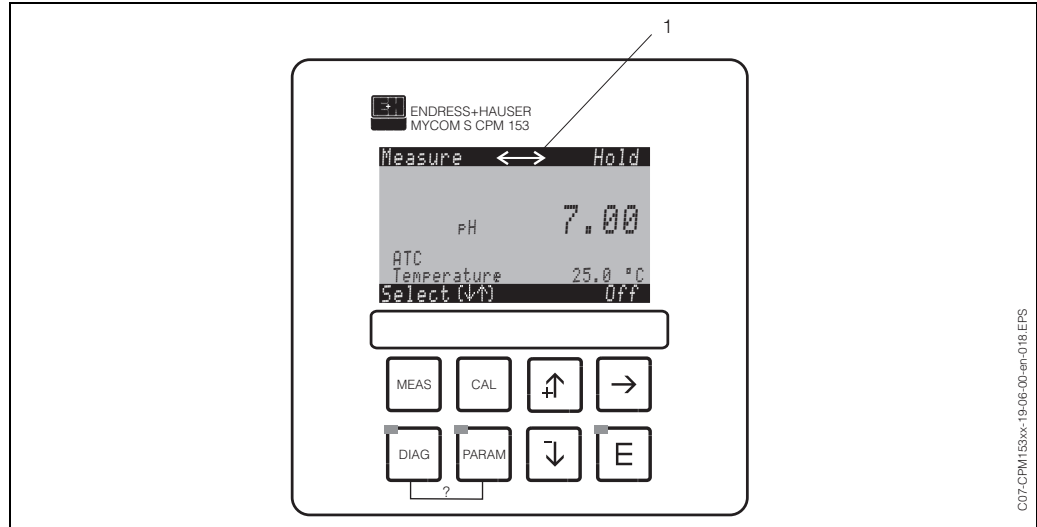

Fig. 8: User interface Mycom S CXM 153
 1 = Display for active communication via HART® interface
 Please refer to the standard Operating Instructions for an explanation of the key assignment and the other icons.

5.2 Operation via the HART® handheld terminal DXR 275

The HART® handheld terminal DXR 275 is operated by means of push buttons with which the instrument functions on a special HART® function matrix are selected. Please refer to the "Communicator DXR 275" Operating Instructions which are supplied with the handheld terminal for information on the operation of the HART® handheld terminal DXR 275.

When operating by means of the handheld terminal, the functions are limited to Universal Commands and Common Practice Commands, (→ page 15).

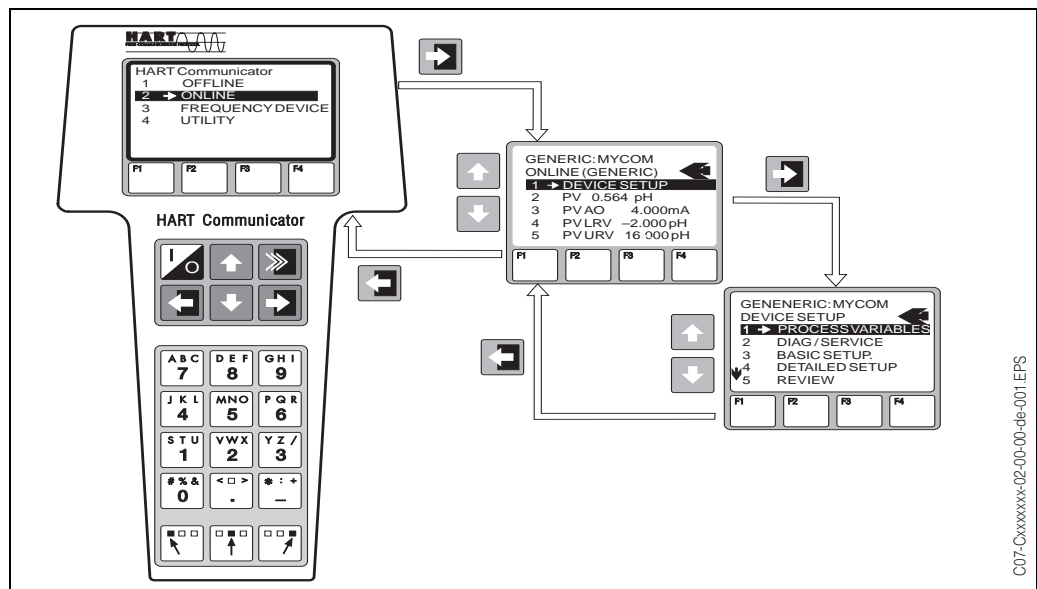

Fig. 9: Operating the HART® handheld terminal DXR 275

5.3 Operation via Commuwin II

Commuwin II is a graphic operating programme with various communication protocols. Connection to Commuwin II is by means of the HART® modem Commubox FXA 191. The parameters are configured either by means of the keypad or by means of the graphic interface. In addition, measured values can be displayed and recorded with a line recorder.

Commuwin II supports the configuration of the transmitter in on-line mode only. The entire Mycom S operating menu cannot be accessed via Commuwin II. The following diagrams illustrate the functions available.

In addition, the field codes of the instrument functions are displayed in the matrix positions.

	H0	H1	H2	H3	H4	H5	H6	H7	H8	H9
V0 MAIN PARAMETER	0.00 pH	13.34 °C	On	0 s	A7 linear	2.00 pH	EAA1 16.00 pH	EAA1		
	PRIMARY VALUE	SECONDARY VAL	HOLD STATUS	DAMPING 1.PV	TRANSMISSION F	LOWER RANGE VA	UPPER RANGE VA			
V1 CURRENT OUTPUT	0.0%	4.00 mA	0.00 mA	YB1						
	PERCENT SPAN	CURRENT VALUE	CURRENT SIMUL							
V2 DEVICE STATUS	E003	U Off	RC1 TOPCAL					Off		
	FAULT	MANUAL HOLD	VERSION					RESET		
V3 CALIBRATION DATA	59 mV	CAB11 59.1 mV/pH	CAB11	16:20	YAA 30.11.2001	YAA 59 mV	CAB11 59.1 mV/pH	CAB11	16:20	YAA 30.11.2001
	ZERO POINT CH1	SLOPE CH1		TIME CH1	DATE CH1	ZERO POINT CH2	SLOPE CH2		TIME CH2	DATE CH2
V4 TOPCAL/TOPCLEAN	no act. progr	N1 Off	NA1 Off	NA1 On	I1 Measuring					
	ACTIVE PROGRA	AUTOMATIC	EXT. CONTROL	HOLD SOURCE	ASSEMBLY POSIT					
V5 CHEMOCLEAN	no act. progr	RB2 Off	O1 Off	O1						
	ACTIVE PROGRA	AUTOMATIC	EXT. CONTROL							
V6 CONTROLLER	Off	M1 9.00 pH	ME7 50%	ME7	pH	pH	pH	pH	pH	pH
	CONTROLLER	SETPOINT	SET VALUE		UNIT SV	UNIT LC1	UNIT LC2	UNIT LC3	UNIT LC4	UNIT LC5
V7 LIMIT CONTACTOR	Off	PA1 Off	PB1 Off	PC1 Off	PD1 Off	PE1 12.00 pH	PA2 12.00 pH	PB2 12.00 pH	PC2 12.00 pH	PD2 12.00 pH
	LC1	LC2	LC3	LC4	LC5	LC1 ALARM THRES	LC2 ALARM TRHES	LC3 ALARM THRES	LC4 ALARM THRES	LC5 ALARM THRES
V8 LIMIT CONTACTOR	8.50 pH	PA1 8.50 pH	PB1 8.50 pH	PC1 8.50 pH	PD1 8.50 pH	PE1 7.00 pH	PA1 7.00 pH	PB1 7.00 pH	PC1 7.00 pH	PD1 7.00 pH
	LC1 OFF THRESH	LC2 OFF THRESH	LC3 OFF THRESH	LC4 OFF THRESH	LC5 OFF THRESH	LC1 ON THRESH	LC2 ON THRESH	LC3 ON THRESH	LC4 ON THRESH	LC5 ON THRESH
V9 SENSOR DATA PV	4711	-2.00 pH	16.00 pH		0.04 pH	16:47	25.10.02	0.06 pH	16:47	25.10.02
	SERIAL NUMBER	LOWER LIMIT	UPPER LIMIT		DELTA BUFFER 1	TIME BUFFER 1	DATE BUFFER 1	DELTA BUFFER 2	TIME BUFFER 2	DATE BUFFER 2
VA DEVICE DATA	MYCOM 153	Message	Description	123486	4261986	201	YF1 1	5	1	5
	TAG NO.	MESSAGE	DESCRIPTOR	ASSEMBLY NUMB	DATE	SW VERSION	HW VERSION	UNIV COMMAND R	DEV COMMAND R	NO. OF PREAMBLE

Fig. 10: Operation of Mycom S CPM 153 via the operating programme Commuwin II



Note!

- Re matrix position V1H2: Value "0 mA" switches off the current simulation.
- Re matrix positions V4H0 and V5H0. To make it possible to activate a programme via HART®, you must first switch on the external control (V4H2 or V5H2). Currently running programmes cannot be aborted via HART®. Field V4H4 is used for monitoring and remote control of the assembly. Remote control is only possible if the TopCal S service switch is set to "Measure".

	H0	H1	H2	H3	H4	H5	H6	H7	H8	H9
V0 MAIN PARAMETER	55.00 mS/cm PRIMARY VALUE	13.34 °C SECONDARY VAL	On HOLD STATUS	0.00 s DAMPING 1.PV	A7 linear TRANSMISSION F	0.00 mS/cm LOWER RANGE VA	EAA1 500.0 mS/cm UPPER RANGE VA			
V1 CURRENT OUTPUT	0.00% PERCENT SPAN	4.00 mA CURRENT VALUE	0.00 mA CURRENT SIMUL	YB1						
V2 DEVICE STATUS	E003 FAULT	U Off MANUAL HOLD	RC1				Aus RESET			
V3 CALIBRATION DATA	2.0 1/cm CELL CONST. CH1	CAB11 1.0 INST. FACT. CH1	CAB11 0.39 mS/cm AIRSET VAL. CH1	16:20 TIME CH1	YAA 30.11.2001 DATE CH1	YAA 2.0 1/cm CELL CONST. CH2	CAB11 1.0 INST. FACT. CH2	CAB11 0.39 mS/cm AIRSET VAL. CH2	16:20 TIME CH2	YAA 30.11.2001 DATE CH2
V4 TOPCAL/TOPCLEAN	1 ACTIVE PS	N1 2 NO. BIN. INPUTS	NA1							
V5 CHEMOCLEAN	no act. progr ACTIVE PROGR	RB2 Off AUTOMATIC	O1 Off EXT. CONTROL	O1						
V6 CONTROLLER	Off CONTROLLER	M1 500.0 mS/cm SETPOINT	ME7 50% SET VALUE	ME7	%	%	%	%	%	%
V7 LIMIT CONTACTOR	Off LC1	PA1 Off LC2	PB1 Off LC3	PC1 Off LC4	PD1 Off LC5	PE1 1000.0 mS/cm LC1 ALARM TRES	PA2 1000.0 mS/cm LC2 ALARM TRES	PB2 1000.0 mS/cm LC3 ALARM TRES	PC2 1000.0 mS/cm LC4 ALARM TRES	PD2 1000.0 mS/cm LC5 ALARM TRES
V8 LIMIT CONTACTOR	100.0 mS/cm LC1 OFF THRESH	PA1 100.0 mS/cm LC2 OFF THRESH	PB1 100.0 mS/cm LC3 OFF THRESH	PC1 100.0 mS/cm LC4 OFF THRESH	PD1 100.0 mS/cm LC5 OFF THRESH	PE1 500.0 mS/cm LC1 ON THRESH	PA1 500.0 mS/cm LC2 ON THRESH	PB1 500.0 mS/cm LC3 ON THRESH	PC1 500.0 mS/cm LC4 ON THRESH	PD1 500.0 mS/cm LC5 ON THRESH
V9 SENSOR DATA PV	4711 SERIAL NUMBER	0.0 mS/cm LOWER LIMIT	2000.0 mS/cm UPPER LIMIT	Conductive TYPE OF SENSOR						
VA DEVICE DATA	MYCOM 153 TAG NO.	Message MESSAGE	Description DESCRIPTOR	123456 ASSEMBLY NUMB	4261986 DATE	201 SW VERSION	YF1 1 HW VERSION	5 UNIV COMMAND R	1 DEV COMMAND R	5 NO. OF PREAMBLE

Fig. 11: Operation of Mycom S CLM 153 via the operating programme Commuwin II



Note!

- Re matrix position V1H2: Value "0 mA" switches off the current simulation.
- Re matrix position V4H0: For active parameter set switching, set the number of binary inputs (V4H1) to "0".
- Re matrix position V5H0. To make it possible to activate a programme via HART®, you must first switch on the external control (V5H2). Currently running programmes cannot be aborted via HART®.
- Operation with Commuwin II is described in the Operating Instructions BA 124F/00/en.
- Off-line configuration via Commuwin II is not possible.
- The device (incl. TopCal S and TopClean S) can be completely configured offline via the accessory Parawin, (→ page 32). The configuration data can be saved to the DAT memory module. The DAT memory module can then be inserted into the device.

5.4 HART® commands

The HART® protocol allows the transfer of measuring and device data between the HART® master and the field device. The HART® master, such as the handheld terminal or the PC-based operating programmes (Commuwin II), require device description (DD) files. They are used to access all the information in a HART® device. Such information is transferred solely via "commands".

There are three different command classes:

Universal commands:

All HART® devices support and use universal commands. The following functionalities are linked to them:

- Recognising HART® devices
- Reading off digital measured values (pH value, conductivity, temperature etc.)

Common practice commands:



Common practice commands offer functions which are supported and can be executed by many field devices.



Device-specific commands:





These commands allow access to device-specific functions which are not HART® standard. Such commands access individual field device information, for example.





Device descriptions for universal and common practice commands are contained in HART® master systems, (e.g. handheld terminal DXR 275, Emerson AMS, Simatic PDM). In this way, diverse functions can also be operated without a special device description. Device-specific commands always require a special device description.



The following table contains all the commands supported by Mycom S CXM 153.

Command No. HART® command / Access type		Command data (numeric data in decimal form)	Response data (numeric data in decimal form)
Universal commands			
0	Read unique device identifier Access type = Read	none	<p>The device identifier provides information on the device and manufacturer; it cannot be altered.</p> <p>The response consists of a 12 -byte device ID:</p> <ul style="list-style-type: none"> - Byte 0: fixed value 254 - Byte 1: manufacturer ID: 17 = E+H - Byte 2: device type ID: 152 = CPM 153, 153 = CLM 153 conductive 154 = CLM 153 inductive - Byte 3: number of preambles - Byte 4: rev. no. universal commands - Byte 5: rev. no. device-spec. commands - Byte 6: software revision - Byte 7: hardware revision - Byte8: additional device information - Byte 9-11: device identification
1	Read primary process variable Access type = Read	none	<ul style="list-style-type: none"> - Byte 0: HART® unit ID of the primary process variable - Byte 1-4: primary process variable <p><i>Factory setting</i> Primary process variable = main measured value</p> <p> Note! Primary process variable = process variable of current output 1 Secondary process variable = process variable of current output 2</p>
2	Read the primary process variable as current in mA and percentage of the set measuring range Access type = Read	none	<ul style="list-style-type: none"> - Byte 0-3: current current of the current output 1 (= primary process variable) in mA - Byte 4-7: percentage of the set measuring range <p><i>Factory setting</i> Primary process variable = main measured value</p> <p> Note! The primary process variable corresponds to the process variable assigned to current output 1.</p>

Command No. HART® command / Access type		Command data (numeric data in decimal form)	Response data (numeric data in decimal form)
3	Read the primary process variable as current in mA and four dynamic process variables Access type = Read	none	<p>24 bytes are sent as a response:</p> <ul style="list-style-type: none"> – Byte 0-3: current of the current output 1 (= primary process variable) in mA – Byte 4: HART® unit ID of the primary process variable – Byte 5-8: primary process variable – Byte 9: HART® unit ID of the secondary process variable – Byte 10-13: secondary process variable – Byte 14: HART® unit ID of the third process variable – Byte 15-18: third process variable – Byte 19: HART® unit ID of the fourth process variable – Byte 20-23: fourth process variable <p><i>Factory setting</i></p> <ul style="list-style-type: none"> • Primary process variable = main measured value • Secondary process variable = temperature input 1 • Third process variable = not assigned • Fourth process variable = not assigned <p> Note! Primary process variable = process variable of current output 1 Secondary process variable = process variable of current output 2</p>
6	Set HART® short-form address Access type = Write	<p>Byte 0: desired address (0...15)</p> <p><i>Factory setting</i> 0</p> <p> Note! With an address >0 (multi-drop mode), the current output 1 of the primary process variable is fixed at 4 mA. Any current simulation is terminated.</p>	<ul style="list-style-type: none"> – Byte 0: active address
11	Read unique device identifier using the tag Access type = Read	<p>Byte 0-5: tag</p> <p> Note! The tag can be set using command 18. The first 6 characters of the User Tag, which can be directly set at the transmitter, are used for the HART® tag description.</p>	<p>The device identifier provides information on the device and manufacturer; it cannot be altered.</p> <p>The response consists of a 12 -byte device ID if the given tag agrees with the one saved in the device:</p> <ul style="list-style-type: none"> – Byte 0: fixed value 254 – Byte 1: manufacturer ID: 17 = E+H – Byte 2: device type ID: 152 = CPM 153 153 = CLM 153 conductive 154 = CLM 153 inductive – Byte 3: number of preambles – Byte 4: rev. no. universal commands – Byte 5: rev. no. device-spec. commands – Byte 6: software revision – Byte 7: hardware revision – Byte 8: additional device information – Byte 9-11: device identification

Command No. HART® command / Access type		Command data (numeric data in decimal form)	Response data (numeric data in decimal form)
12	Read user message Access type = Read	none	<ul style="list-style-type: none"> – Byte 0-23: current user message <p> Note! You can write the user message using command 17.</p>
13	Read tag, tag description and date Access type = Read	none	<ul style="list-style-type: none"> – Byte 0-5: tag – Byte 6-17: tag description – Byte 18-20: date <p> Note! You can write the tag, tag description and date using command 18.</p>
14	Read sensor information on the primary process variable Access type = Read	none	<ul style="list-style-type: none"> – Byte 0-2: serial number of the sensor – Byte 3: HART®unit ID of the sensor limits and measuring range of the primary process variable – Byte 4-7: upper sensor limit – Byte 8-11: lower sensor limit – Byte 12-15: minimum distance between the limits <p> Note! Depending on the assignment of the current output 1, the sensor information is provided from sensor 1 or sensor 2.</p>
15	Read output information of primary process variable Access type = Read	none	<ul style="list-style-type: none"> – Byte 0: alarm selection ID – Byte 1: ID for transfer function – Byte 2: HART®unit ID for the set measuring range of the primary process variable – Byte 3-6: end of measuring range, value for 20 mA – Byte 7-10: start of measuring range, value for 4 mA – Byte 11-14: attenuation constants in s – Byte 15: ID for write protection – Byte 16: ID for OEM dealer: 17 = E+H <p><i>Factory setting</i> Primary process variable = main measured value</p> <p> Note! Primary process variable = process variable of current output 1 Secondary process variable = process variable of current output 2</p>
16	Read the device production number Access type = Read	none	<ul style="list-style-type: none"> – Byte 0-2: production number <p> Note! You can write the production number using command 19.</p>
17	Write user message Access type = Write	<p>You can save any 32-character long text in the device with this parameter:</p> <p>Byte 0-23: desired user message</p>	<ul style="list-style-type: none"> – Byte 0-23: current user message

Command No. HART® command / Access type		Command data (numeric data in decimal form)	Response data (numeric data in decimal form)
18	Write tag, tag description and date Access type = Write	You can save an 8-character tag, a 16-character tag description and a date with this parameter: – Byte 0-5: tag – Byte 6-17: tag description – Byte 18-20: date  Note! If you change the tag description, also the User Tag changes automatically.	– Byte 0-5: tag – Byte 6-17: tag description – Byte 18-20: date
19	Write the device production number Access type = Write	You can save a production number in the range of 0 ... 1677715 with this parameter.	– Byte 0-2: production number
Common practice commands			
34	Write attenuation constants for primary process variable Access type = Write	– Byte 0-3: attenuation constants of the primary process variable in seconds <i>Factory setting</i> Primary process variable = main measured value	– Byte 0-3: attenuation constants in seconds
35	Write measuring range of primary process variable Access type = Write	Write the desired measuring range: – Byte 0: HART unit ID for the primary process variable – Byte 1-4: end of measuring range, value for 20 mA – Byte 5-8: start of measuring range, value for 4 mA <i>Factory setting:</i> Primary process variable = main measured value	– Byte 0: HART® unit ID for the set measuring range of the primary process variable – Byte 1-4: end of measuring range, value for 20 mA – Byte 5-8: start of measuring range, value for 4 mA  Note! Manufacturer-specific units for HART® see table → page 20
38	Device status reset "configuration changed" Access type = Write	none	none
40	Simulate output current of primary process variable Access type = Write	Simulation of the desired output current of the primary process variable. An entry value of 0 exits the simulation mode: Byte 0-3: output current in mA <i>Factory setting:</i> Primary process variable = main measured value  Note! Values between 2 and 22 mA can be simulated. Current simulation is not possible if the device is in multi-drop mode.	– Byte 0-3: output current in mA
42	Perform device reset Access type = Write	none  Note! Communication is not possible during the device initialisation which is necessary after a reset, (approx. 15 s).	none

Command No. HART® command / Access type		Command data (numeric data in decimal form)	Response data (numeric data in decimal form)
44	Write unit of the primary process variable Access type = Write	Specify the unit of primary process variable. Only units which are suitable for the process variable are accepted by the device: Byte 0: HART® unit ID <i>Factory setting:</i> Primary process variable = main measured value  Note! • The unit cannot really be changed. This command only exists for compatibility reasons.	– Byte 0: HART® unit ID  Note! Manufacturer-specific units for HART® see table → page 20
48	Read extended device status Access type = Read	none	Coding: see table → page 23
59	Specify number of preambles in message responses Access type = Write	This parameter specifies the number of preambles which are inserted in the message responses: Byte 0: number of preambles (2...20)	– Byte 0: number of preambles
Device-specific commands			
144	Read VH matrix variable Access type = Read	The Commuwin II variables are read with this command. – Byte 0: VH position lower 4 bits: H upper 4 bits: V	– Byte 0: VH position lower 4 bits: H upper 4 bits: V – Byte 1: HART® unit ID – Byte 2 ... n: VH variable
145	Write VH matrix variable Access type = Write	The Commuwin II variables are written with this command. – Byte 0: VH position lower 4 bits: H upper 4 bits: V – Byte 1: HART® unit ID – Byte 2 ... n: VH variable	– Byte 0: VH position lower 4 bits: H upper 4 bits: V – Byte 1: HART® unit ID – Byte 2 ... n: VH variable

Manufacturer-specific units for HART®

Decimal	Hexadecimal	Unit
240	F0	S/m
241	F1	kΩ•cm
242	F2	MΩ•cm
243	F3	1/cm
245	F5	mg/l
246	F6	S/cm

6 Commissioning

6.1 Function check



Caution!

- Before power-up, check all the connections again for correctness.
- Make sure that the sensors and, if necessary, the temperature sensor are in the medium or in a buffer solution, as otherwise no plausible measured value can be displayed.
- Make sure also that the post-connection check has been carried out, (s. chap. 4.2).



Warning!

Before power-up, make sure there is no danger to the measuring point. Uncontrolled actuated pumps, valves or similar could lead to damage to instruments.

6.2 Setting the device address

All HART® devices have the device address 0 on leaving the factory. This address can be changed to connect up several devices for HART® communication to the network, (multi-drop operation).

The device address can be set via

- local operation or
- handheld terminal DXR 275 or
- operating programme Commuwin II.

Setting the device address via the Mycom S operating menu

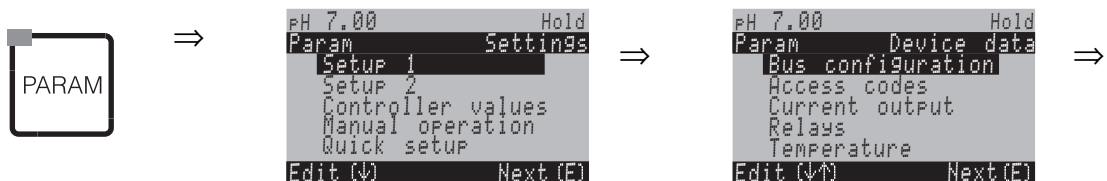

CODE	Display	CHOICE (default = bold)	INFO	User settings
C1		0 0...15	Entry of the bus address Each address may only be given once in a network. If a device address ≠ 0 is selected, the current output is automatically set to 4 mA and the device is set to multi-drop operation.	
C2		-	Tag from Field T22 Here display only; cannot be edited.	

7 Maintenance



Note!

Please refer to the standard Operating Instructions BA 233C/07/en or BA 234/07/en for information on maintenance of the measuring point.

8 Troubleshooting



Note!

Please refer to the standard Operating Instructions BA 233C/07/en or BA 234/07/en for information on troubleshooting requiring user input.

8.1 Device status / error messages

You can read the extended device status or current error messages via command 48. The command delivers bit-encoded information.

8.1.1 Error messages Mycom S CPM 153

Byte	NAMUR	Bit	Error no.	Short error description
0	F A I L U R E	0	E000	Not used
		1	E001	Memory error
		2	E002	Data error in the EEPROM
		3	E003	Invalid configuration
		4	E004	Invalid hardware ID
		5	E005	Unknown CPG code
		6	E006	Malfunction of transmitter 2
1		7	E007	Malfunction of transmitter 1
		0	E008	SCS message sensor 1 / IsFET 1 (IsFET leak current 1 > 400 nA)
		1	E009	SCS message sensor 2 / IsFET 2 (IsFET leak current 2 > 400 nA)
		2	E010	Temperature sensor 1 defective
		3	E011	Temperature sensor 2 defective
		4	E012	CPC communication failure
		5	E013	Assembly has not reached service position
2		6	E014	Assembly has not reached measuring position
		7	E015	Revolver does not turn
		0	E016	Revolver end position recognition defective
		1	E017	Data error in CPC EEPROM
		2	E018	Not used
		3	E019	Delta limit exceeded
		4	E020	Not used
5	E021	Not used		
6	E022	Not used		
7	E023	Not used		

Byte	NAMUR	Bit	Error no.	Short error description
3	F A I L U R E	0	E024	CPC programme interrupted
		1	E025	Not used
		2	E026	Not used
		3	E027	Compressed air failure
		4	E028	Not used
		5	E029	Not used
		6	E030	SCS fault reference electrode 1
		7	E031	SCS fault reference electrode 2
4		0	E032	Outside set slope range for sensor 1
		1	E033	Outside set zero point for sensor 1
		2	E034	Outside set offset range for sensor 1
		3	E035	Outside set slope range for sensor 2
		4	E036	Outside set zero point for sensor 2
		5	E037	Outside set offset range for sensor 2
		6	E038	Delta limit exceeded
		7	E039	Not used
5		0	E040	SCC / electrode status of sensor 1 bad
		1	E041	SCC / electrode status of sensor 2 bad
		2	E042	Not used
		3	E043	Buffer difference of input 1 too small
		4	E044	Meas. value input 1 unstable
		5	E045	Calibration aborted
		6	E046	Not used
		7	E047	Not used
6		0	E048	Buffer difference of input 2 too small
		1	E049	Meas. value input 2 unstable
		2	E050	Cleaner almost empty
		3	E051	Buffer 1 almost empty
		4	E052	Buffer 2 almost empty
		5	E053	Actuator failure
		6	E054	Dosing time monitor
		7	E055	Measuring range of main parameter 1 undershot
7		0	E056	Measuring range of main parameter 1 undershot
		1	E057	Measuring range of main parameter 1 exceeded
		2	E058	Measuring range of main parameter 2 exceeded
		3	E059	Temperature measuring range 1 undershot
		4	E060	Temperature measuring range 2 undershot
		5	E061	Temperature measuring range 1 exceeded
		6	E062	Temperature measuring range 2 exceeded
		7	E063	Current output 1 below range

Byte	NAMUR	Bit	Error no.	Short error description
8	F A I L U R E	0	E064	Current output 1 above range
		1	E065	Current output 2 below range
		2	E066	Current output 2 above range
		3	E067	Setpoint exceeded controller / limit contactor 1
		4	E068	Setpoint exceeded controller / limit contactor 2
		5	E069	Setpoint exceeded controller / limit contactor 3
		6	E070	Setpoint exceeded controller / limit contactor 4
		7	E071	Setpoint exceeded controller / limit contactor 5
9		0	E072	Not used
		1	E073	Temperature 1, table value undershot
		2	E074	Temperature 2, table value undershot
		3	E075	Temperature 1, table value exceeded
		4	E076	Temperature 2, table value exceeded
		5	E077	Not used
		6	E078	Not used
		7	E079	Not used
10		0	E080	Range for current output 1 too small
		1	E081	Range for current output 2 too small
		2	E082	Not used
		3	E083	Not used
		4	E084	Not used
		5	E085	Not used
		6	E086	Delta limit buffer 1 exceeded
		7	E087	Delta limit buffer 2 exceeded
11	F U N C T I O N C O N T R O L	0	E088	Not used
		1	E089	Not used
		2	E090	CPC service switch active
		3	E091	Not used
		4	E092	Not used
		5	E093	Not used
		6	E094	Not used
		7	E095	Not used
12		0	E096	Not used
		1	E097	Not used
		2	E098	Not used
		3	E099	Not used
		4	E100	Current simulation active
		5	E101	Service function active
		6	E102	Not used
		7	E103	Not used

Byte	NAMUR	Bit	Error no.	Short error description
13	F U N C T I O N C O N T R O L	0	E104	Not used
		1	E105	Not used
		2	E106	Download active
		3	E107	Not used
		4	E108	Not used
		5	E109	Not used
		6	E110	Not used
		7	E111	Not used
14		0	E112	Not used
		1	E113	Not used
		2	E114	Not used
		3	E115	Not used
		4	E116	Download error
		5	E117	DAT updownload error
		6	E118	Not used
7	E119	Not used		
15-16	0-7	E120-127	Not used	
16	0-7	E128-135	Not used	
17	0-7	E136-144	Not used	
18	0-7	E144-151	Not used	
19	M A I N T E N A N C E R E Q U I R E D	0	E152	PCS channel 1 alarm
		1	E153	PCS channel 2 alarm
		2	E154	Not used
		3	E155	Not used
		4	E156	Calibration timer run out
		5	E157	Not used
		6	E158	Not used
		7	E159	Not used
20		0	E160	Not used
		1	E161	Not used
		2	E162	Not used
		3	E163	Not used
		4	E164	Dynamic range of pH convertor 1 exceeded
		5	E165	Dynamic range of pH convertor 2 exceeded
		6	E166	Dynamic range of reference convertor 1 exceeded
	7	E167	Dynamic range of reference convertor 2 exceeded	

Byte	NAMUR	Bit	Error no.	Short error description
21	M A I N T E N A N C E	0	E168	SCS message IsFET sensor 1 (IsFET leak current 1 > 200 nA)
		1	E169	SCS message IsFET sensor 2 (IsFET leak current 2 > 200 nA)
		2	E170	Not used
		3	E171	Current input 1 below range
		4	E172	Current/resistance input 1 above range
		5	E173	Current input 2 below range
		6	E174	Current input 2 above range
		7	E175	Not used

8.1.2 Error messages Mycom S CLM 153

Byte	NAMUR	Bit	Error no.	Short error description
0	F A I L U R E	0	E000	Not used
		1	E001	Memory error
		2	E002	Data error in the EEPROM
		3	E003	Invalid configuration
		4	E004	Invalid hardware ID
		5	E005	Not used
		6	E006	Malfunction of transmitter 2
		7	E007	Malfunction of transmitter 1
1		0	E008	Malfunction of sensor 1
		1	E009	Malfunction of sensor 2
		2	E010	Temperature sensor 1 defective
		3	E011	Temperature sensor 2 defective
		4	E012	Not used
		5	E013	Not used
		6	E014	Not used
		7	E015	Not used
2		0	E016	Not used
		1	E017	Not used
		2	E018	Not used
		3	E019	Delta limit exceeded
		4	E020	Not used
		5	E021	Not used
		6	E022	Not used
		7	E023	Not used

Byte	NAMUR	Bit	Error no.	Short error description
3	F A I L U R E	0	E024	Not used
		1	E025	Airset error sensor 1
		2	E026	Airset error sensor 2
		3	E027	Not used
		4	E028	Not used
		5	E029	Not used
		6	E030	Not used
		7	E031	Not used
4		0	E032	Not used
		1	E033	Not used
		2	E034	Cell constant, sensor 1 exceeded
		3	E035	Cell constant, sensor 1 undershot
		4	E036	Cell constant, sensor 2 exceeded
		5	E037	Cell constant, sensor 2 undershot
		6	E038	Delta limit exceeded
		7	E039	Not used
5		0	E040	Not used
		1	E041	Not used
		2	E042	Not used
		3	E043	Not used
		4	E044	Not used
		5	E045	Not used
		6	E046	Installation factor, sensor 1 exceeded
		7	E047	Installation factor, sensor 1 undershot
6		0	E048	Installation factor, sensor 2 exceeded
		1	E049	Installation factor, sensor 2 undershot
		2	E050	Not used
		3	E051	Not used
		4	E052	Not used
		5	E053	Three ps error
		6	E054	Dosing time monitor
		7	E055	Measuring range of main parameter 1 undershot
7		0	E056	Measuring range of main parameter 1 undershot
		1	E057	Measuring range of main parameter 1 exceeded
		2	E058	Measuring range of main parameter 2 exceeded
		3	E059	Temperature measuring range 1 undershot
		4	E060	Temperature measuring range 2 undershot
		5	E061	Temperature measuring range 1 exceeded
		6	E062	Temperature measuring range 2 exceeded
		7	E063	Current output 1 below range

Byte	NAMUR	Bit	Error no.	Short error description
8	F A I L U R E	0	E064	Current output 1 above range
		1	E065	Current output 2 below range
		2	E066	Current output 2 above range
		3	E067	Setpoint exceeded controller / limit contactor 1
		4	E068	Setpoint exceeded controller / limit contactor 2
		5	E069	Setpoint exceeded controller / limit contactor 3
		6	E070	Setpoint exceeded controller / limit contactor 4
		7	E071	Setpoint exceeded controller / limit contactor 5
9		0	E072	Polarisation error sensor 1
		1	E073	Polarisation error sensor 2
		2	E074	Temperature outside alpha value table 1
		3	E075	Temperature outside concentration table 1
		4	E076	Conductivity outside concentration table 1
		5	E077	Temperature outside alpha table 2
		6	E078	Temperature outside concentration table 2
		7	E079	Conductivity outside concentration table 2
10		0	E080	Range for current output 1 too small
		1	E081	Range for current output 2 too small
		2	E082	Not used
		3	E083	Not used
		4	E084	Not used
		5	E085	Not used
		6	E086	Not used
		7	E087	Not used
11	F U N C T I O N C O N T R O L	0	E088	Not used
		1	E089	Not used
		2	E090	Not used
		3	E091	Not used
		4	E092	Not used
		5	E093	Not used
		6	E094	Not used
		7	E095	Not used
12		0	E096	Not used
		1	E097	Not used
		2	E098	Not used
		3	E099	Not used
		4	E100	Current simulation active
		5	E101	Service function active
		6	E102	Not used
		7	E103	Not used

Byte	NAMUR	Bit	Error no.	Short error description
13	F U N C T I O N C O N T R O L	0	E104	Not used
		1	E105	Not used
		2	E106	Download active
		3	E107	Not used
		4	E108	Not used
		5	E109	Not used
		6	E110	Not used
		7	E111	Not used
14		0	E112	Not used
		1	E113	Not used
		2	E114	Not used
		3	E115	Not used
		4	E116	Download error
		5	E117	DAT updownload error
		6	E118	Not used
7	E119	Not used		
15-16	0-7	E120-127	Not used	
16	0-7	E128-135	Not used	
17	0-7	E136-144	Not used	
18	0-7	E144-151	Not used	
19	M A I N T E N A N C E R E Q U I R E D	0	E152	PCS channel 1 alarm
		1	E153	PCS channel 2 alarm
		2	E154	USP error 1
		3	E155	USP temp error 1
		4	E156	USP error 2
		5	E157	USP temp error 2
		6	E158	Not used
7		E159	Not used	
20		0	E160	Not used
		1	E161	Not used
		2	E162	Not used
		3	E163	Not used
		4	E164	Not used
		5	E165	Not used
	6	E166	Not used	
	7	E167	Not used	

Byte	NAMUR	Bit	Error no.	Short error description
21	M A I N T E N A N C E	0	E168	Not used
		1	E169	Not used
		2	E170	Not used
		3	E171	Current input 1 below range
		4	E172	Current/resistance input 1 above range
		5	E173	Current input 2 below range
		6	E174	Current input 2 above range
		7	E175	Not used

9 Accessories

DXR 275

HART® handheld terminal DXR 275

Handheld terminal for communicating with every HART®-compatible device via a 4...20 mA line.

Order No.: DXR 275

Commubox FXA 191

HART® modem Commubox FXA 191

Interface module between HART® interface and series PC interface

Technical Information TI 237F/00/en

Order No.: 016735-1000

Commuwin II

Operating programme Commuwin II

Graphic PC operating programme for intelligent devices.

System Information SI 003F/04/en

Order No.: 51503952

Parawin

Mycom S Off-line operating programme

Graphic PC operating programme and DAT interface for off-line configuration of Mycom S, TopCal S, TopClean S via DAT memory module.

Order No.: 51507133 (Mycom S)

Order No.: 51507563 (TopCal S, TopClean S)

10 Technical data

10.1 Output

Output signal	pH, redox, conductivity, temperature (depending on device version)	
Current output 1	Current range	4 ... 20 mA
	Load	230 ... 1100 Ω
	Power supply with passive current output	24 V DC

10.2 Electrical connection

Electrical connection data	Power supply	100 ... 230 V AC +10/-15 %, 24 V AC/DC
	Frequency	47 ... 64 Hz
	Power consumption	max. 7.5 VA

10.3 Human interface

Operating elements	On-site operation	Via HART® handheld terminal DXR 275
	PC operation	Via HART® modem Commubox FXA 191 with operating programme Commuwin II
	Device address	Can be set, 0 ... 15

10.4 Documentation

Commuwin II	System Information SI 003F/04/en	Order No.: 51503952
	Operating Instructions BA 124F/00/a2	Order No.: 52000549
	Technical Information TI 237F/00/en	Order No.: 016735-1000

11 Index

A

Active current output 9–10

B

Bus address 21

C

Certificates and approvals 6

Commissioning 5, 21

Commubox FXA 191 10, 32

Commuwin II 10, 13, 32

Commuwin II operating programme 10, 13, 32

Connecting a PC with operating programme 10

Current output, active 9–10

Current output, passive 9–10

D

Declaration of conformity 6

Designated use 5

Device address 21

Device status 23

Display and operating elements 12

E

Electrical connection 8

Electrical connection of the Commubox FXA 191 10

Error messages 23

 Mycom S CLM 153 27

 Mycom S CPM 153 23

F

Function 21

Function check 21

H

HART® commands 15–16

 Common practice commands 19

 Device-specific commands 20

 Universal commands 16

HART® handheld terminal DXR 275 12, 32

HART® modem Commubox FXA 191 10, 32

HART® protocol 15

I

Identification 6

Installation 5, 7

M

Maintenance 22

O

Operation 5, 12

Operation via Commuwin II 13

 Mycom S CLM 153 14

 Mycom S CPM 153 13

Operational safety 5

P

Parawin 14, 32

Parawin operating programme 14, 32

Passive current output 9–10

Post-connection check 11

Post-installation check 7

Q

Quick connection guide 8

S

Safety conventions 4

Safety icons 4

Safety instructions 4

Scope of delivery 6

Setting the device address 21

System architecture 7

T

Technical data 33

 Electrical connection 33

 Human interface 33

 Output 33

Troubleshooting 23

W

Wiring diagram 8

Declaration of contamination

Dear customer,
Because of legal determinations and for the safety of our employees and operating equipment we need this "Declaration of contamination" with your signature before your order can be handled. Please put the completely filled in declaration to the instrument and to the shipping documents in any case. Add also safety sheets and/or specific handling instructions if necessary.

type of instrument / sensor: _____ serial number: _____
medium / concentration: _____ temperature: _____ pressure: _____
cleaned with: _____ conductivity: _____ viscosity: _____

Warning hints for medium used:

							
<input type="checkbox"/>	<input type="checkbox"/>	<input type="checkbox"/>	<input type="checkbox"/>	<input type="checkbox"/>	<input type="checkbox"/>	<input type="checkbox"/>	<input type="checkbox"/>
radioactive	explosive	caustic	poisonous	harmful of health	biological hazardous	inflammable	safe

Please mark the appropriate warning hints.

Reason for return:

Company data:

company: _____	contact person: _____
_____	_____
_____	department: _____
address: _____	phone number: _____
_____	Fax/E-Mail: _____
_____	your order no.: _____

I hereby certify that the returned equipment has been cleaned and decontaminated acc. to good industrial practices and is in compliance with all regulations. This equipment poses no health or safety risks due to contamination.

(Date)

(company stamp and legally binding signature)



Europe

Austria

□ Endress+Hauser Ges.m.b.H.
Wien
Tel. (01) 88056-0, Fax (01) 88056-335

Belarus

□ Belorgsintez
Minsk
Tel. (0172) 263166, Fax (0172) 263111

Belgium / Luxembourg

□ Endress+Hauser N.V.
Brussels
Tel. (02) 2480600, Fax (02) 2480553

Bulgaria

INTERTECH-AUTOMATION
Sofia
Tel. (02) 664869, Fax (02) 9631389

Croatia

□ Endress+Hauser GmbH+Co.
Zagreb
Tel. (01) 6637785, Fax (01) 6637823

Cyprus

I+G Electrical Services Co. Ltd.
Nicosia
Tel. (02) 484788, Fax (02) 484690

Czech Republic

□ Endress+Hauser GmbH+Co.
Praha
Tel. (026) 6784200, Fax (026) 6784179

Denmark

□ Endress+Hauser A/S
Søborg
Tel. (70) 131132, Fax (70) 132133

Estonia

ELVI-Aqua
Tartu
Tel. (7) 441638, Fax (7) 441582

Finland

□ Endress+Hauser Oy
Espoo
Tel. (09) 8676740, Fax (09) 86767440

France

□ Endress+Hauser S.A.
Huningue
Tel. (389) 967668, Fax (389) 694802

Germany

□ Endress+Hauser Messtechnik GmbH+Co.
Weil am Rhein
Tel. (07621) 975-01, Fax (07621) 975-555

Great Britain

□ Endress+Hauser Ltd.
Manchester
Tel. (0161) 2865000, Fax (0161) 9981841

Greece

I & G Building Services Automation S.A.
Athens
Tel. (01) 9241500, Fax (01) 9221714

Hungary

Mile Ipari-Elektro
Budapest
Tel. (01) 4319800, Fax (01) 4319817

Iceland

BIL ehf
Reykjavik
Tel. (05) 619616, Fax (05) 619617

Ireland

Flomeaco Company Ltd.
Kildare
Tel. (045) 868615, Fax (045) 868182

Italy

□ Endress+Hauser S.p.A.
Cernusco s/N Milano
Tel. (02) 921921, Fax (02) 92107153

Latvia

Rino TK
Riga
Tel. (07) 312897, Fax (07) 312894

Lithuania

UAB "Agava"
Kaunas
Tel. (07) 202410, Fax (07) 207414

Netherlands

□ Endress+Hauser B.V.
Naarden
Tel. (035) 6958611, Fax (035) 6958825

Norway

□ Endress+Hauser A/S
Tranby
Tel. (032) 859850, Fax (032) 859851

Poland

□ Endress+Hauser Polska Sp. z o.o.
Raszyn
Tel. (022) 7201090, Fax (022) 7201085

Portugal

Tecnisis - Tecnica de Sistemas Industriais
Linda-a-Velha
Tel. (21) 4267290, Fax (21) 4267299

Romania

Romconseng S.R.L.
Bucharest
Tel. (01) 4101634, Fax (01) 4101634

Russia

□ Endress+Hauser Moscow Office
Moscow
Tel. (095) 1587564, Fax (095) 1589871

Slovakia

Transcom Technik s.r.o.
Bratislava
Tel. (7) 44888684, Fax (7) 44887112

Slovenia

□ Endress+Hauser D.O.O.
Ljubljana
Tel. (061) 5192217, Fax (061) 5192298

Spain

□ Endress+Hauser S.A.
Sant Just Desvern
Tel. (93) 4803366, Fax (93) 4733839

Sweden

□ Endress+Hauser AB
Sollentuna
Tel. (08) 55511600, Fax (08) 55511655

Switzerland

□ Endress+Hauser Metso AG
Reinach/BL 1
Tel. (061) 7157575, Fax (061) 7111650

Turkey

Intek Endüstriyel Ölçü ve Kontrol Sistemleri-
tanbul
Tel. (0212) 2751355, Fax (0212) 2662775

Ukraine

Photonika GmbH
Kiev
Tel. (44) 26881, Fax (44) 26908

Yugoslavia Rep.

Meris d.o.o.
Beograd
Tel.(11) 4441966, Fax (11) 4441966

Africa

Egypt

Anasia
Heliopolis/Cairo
Tel. (02) 4179007, Fax (02) 4179008

Morocco

Oussama S.A.
Casablanca
Tel. (02) 241338, Fax (02) 402657

South Africa

□ Endress+Hauser Pty. Ltd.
Sandton
Tel. (011) 4441386, Fax (011) 4441977

Tunisia

Controlre. Maintenance et Regulation
Tunis
Tel. (01) 793077, Fax (01) 788595

America

Argentina

□ Endress+Hauser Argentina S.A.
Buenos Aires
Tel. (01) 145227970, Fax (01) 145227909

Bolivia

Tritec S.R.L.
Cochabamba
Tel. (042) 56993, Fax (042) 50981

Brazil

□ Samson Endress+Hauser Ltda.
Sao Paulo
Tel. (011) 50313455, Fax (011) 50313067

Canada

□ Endress+Hauser Ltd.
Burlington, Ontario
Tel. (905) 6819292, Fax (905) 6819444

Chile

□ Endress+Hauser Chile Ltd.
Santiago
Tel. (02) 3213009, Fax (02) 3213025

Colombia

Colsein Ltda.
Bogota D.C.
Tel. (01) 2367659, Fax (01) 6104186

Costa Rica

EURO-TEC S.A.
San Jose
Tel. (02) 961542, Fax (02) 961542

Ecuador

Insetec Cia. Ltda.
Quito
Tel. (02) 269148, Fax (02) 461833

Guatemala

ACISA Automatizacion Y Control Industrial S.A.
Ciudad de Guatemala, C.A.
Tel. (03) 345985, Fax (03) 327431

Mexico

□ Endress+Hauser S.A. de C.V.
Mexico City
Tel. (5) 5682405, Fax (5) 5687459

Paraguay

Incoel S.R.L.
.Asuncion
Tel. (021) 213989, Fax (021) 226583

Uruguay

Circular S.A.
Montevideo
Tel. (02) 925785, Fax (02) 929151

USA

□ Endress+Hauser Inc.
Greenwood, Indiana
Tel. (317) 535-7138, Fax (317) 535-8498

Venezuela

Controlval C.A.
Caracas
Tel. (02) 9440966, Fax (02) 9444554

Asia

China

□ Endress+Hauser Shanghai
Instrumentation Co. Ltd.
Shanghai
Tel. (021) 54902300, Fax (021) 54902303

□ Endress+Hauser Beijing Office

Beijing
Tel. (010) 68344058, Fax: (010) 68344068

Hong Kong

□ Endress+Hauser HK Ltd.
Hong Kong
Tel. 25283120, Fax 28654171

India

□ Endress+Hauser (India) Pvt Ltd.
Mumbai
Tel. (022) 8521458, Fax (022) 8521927

Indonesia

PT Grama Bazita
Jakarta
Tel. (21) 7975083, Fax (21) 7975089

Japan

□ Sakura Endress Co. Ltd.
Tokyo
Tel. (0422) 540613, Fax (0422) 550275

Malaysia

□ Endress+Hauser (M) Sdn. Bhd.
Petaling Jaya, Selangor Darul Ehsan
Tel. (03) 7334848, Fax (03) 7338800

Pakistan

Speedy Automation
Karachi
Tel. (021) 7722953, Fax (021) 7736884

Papua-Neuguinea

SBS Electrical Pty Limited
Port Moresby
Tel. 3251188, Fax 3259556

Philippines

□ Endress+Hauser Philippines Inc.
Metro Manila
Tel. (2) 3723601-05, Fax (2) 4121944

Singapore

□ Endress+Hauser (S.E.A.) Pte., Ltd.
Singapore
Tel. 5668222, Fax 5666848

South Korea

□ Endress+Hauser (Korea) Co., Ltd.
Seoul
Tel. (02) 6587200, Fax (02) 6592838

Taiwan

Kingjarl Corporation
Taippei R.O.C.
Tel. (02) 27183938, Fax (02) 27134190

Thailand

□ Endress+Hauser Ltd.
Bangkok
Tel. (2) 9967811-20, Fax (2) 9967810

Vietnam

Tan Viet Bao Co. Ltd.
Ho Chi Minh City
Tel. (08) 8335225, Fax (08) 8335227

Iran

PATSA Co.
Tehran
Tel. (021) 8754748, Fax(021) 8747761

Israel

Instrumetrics Industrial Control Ltd.
Netanya
Tel. (029) 8357090, Fax (03) 8350619

Jordan

A.P. Parpas Engineering S.A.
Amman
Tel. (06) 4643246, Fax (06) 4645707

Kingdom of Saudi Arabia

Anasia Ind. Agencies
Jeddah
Tel. (02) 6710014, Fax (02) 6725929

Lebanon

Network Engineering
Jbeil
Tel. (3) 944080, Fax (9) 548038

Sultanate of Oman

Mustafa & Jawad Sience & Industry Co.
L.L.C.
Ruwi
Tel. 602009, Fax 607066

United Arab Emirates

Descon Trading EST.
Dubai
Tel. (04) 2653651, Fax (04) 2653264

Yemen

YemenCompany for Ghee and Soap Industry
Taiz
Tel. (04) 230664, Fax (04) 212338

Australia + New Zealand

Australia

ALSTOM Australia Limited
Milperra
Tel. (02) 97747444, Fax (02) 97744667

New Zealand

EMC Industrial Group Limited
Auckland
Tel. (09) 4155110, Fax (09) 4155115

All other countries

□ Endress+Hauser GmbH+Co.
Instruments International
D-Weil am Rhein
Germany
Tel. (07621) 975-02, Fax (07621) 975345

<http://www.endress.com>

□ Members of the Endress+Hauser Group 05.00/LC

BA 301C/07/en/11.02
Printed in Germany / FM-SGML 6.0 / DT

Endress + Hauser

The Power of Know How



51507114