

# nivotester

## FTL 375 N-###1

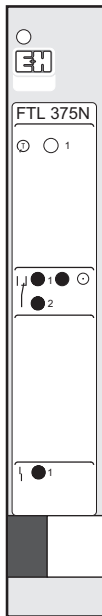

- d** Füllstandgrenschalter mit NAMUR-Eingang
- e** Level Limit Switch with NAMUR input
- f** Détecteur de niveau avec entrée NAMUR
- es** Detector de nivel con entrada NAMUR
- i** Interruttore di livello con ingresso NAMUR
- nl** Niveauschakelaar met NAMUR ingang

<b>d</b>	<b>Inhalt</b>	
	Sicherheitshinweise	4
	Geräte-Identifikation	6
	Messeinrichtung	8
	Einbau	9
	Anschluss	11
	Einstellungen	14
	Bedien- und	
	Anzeigeelemente	21
	Funktion	22
	Funktionstest	25
	Technische Daten	29
	Fehlersuche	31
	Ergänzende	
	Dokumentation	37

<b>e</b>	<b>Contents</b>	
	Notes on Safety	4
	Device Identification	6
	Measuring system	8
	Installation	9
	Connection	11
	Setting-up	14
	User interface elements	21
	Function	22
	Function test	25
	Technical Data	29
	Trouble-shooting	32
	Supplementary	
	Documentation	37

<b>f</b>	<b>Sommaire</b>	
	Conseils de sécurité	4
	Désignation de l'appareil	6
	Ensemble de mesure	8
	Montage	9
	Raccordement	11
	Réglages	14
	Éléments d'affichage et	
	de commande	21
	Fonctionnement	22
	Test de fonctionnement	25
	Caractéristiques	
	techniques	29
	Recherche de défauts	33
	Documentation	
	complémentaire	37

<b>es</b>	<b>Indice</b>	
	Notas sobre seguridad	5
	Identificación del equipo	6
	Sistema de medida	8
	Montaje	9
	Conexiones	11
	Ajuste	14
	Elementos de indicación y función	21
	Funcionamiento	22
	Prueba de funcionamiento	26
	Datos técnicos	30
	Identificación de fallos	34
	Documentación adicional	37

<b>i</b>	<b>Indice</b>	
	Note sulla sicurezza	5
	Identificazione dello strumento	6
	Sistema di misura	8
	Montaggio	9
	Collegamenti	11
	Messa in marcia	14
	Elementi sul frontale	21
	Funzione	22
	Test di funzionalità	26
	Dati tecnici	30
	Individuazione e eliminazione delle anomalie	35
	Documentazione supplementare	37

<b>nl</b>	<b>Inhoud</b>	
	Veiligheidsinstructies	5
	Instrument-identificatie	6
	Meetopstelling	8
	Inbouw	9
	Aansluiting	11
	Instellingen	14
	Bedienings- en aanwijzelementen	21
	Functie	22
	Functie test	26
	Technische gegevens	30
	Fout zoeken	36
	Aanvullende documentatie	37

#### **d Sicherheitshinweise**

Der Nivotester FTL 375 N darf nur als Messumformer-Speisegerät für Grenzschalter mit Zweidraht-NAMUR-Signal verwendet werden.

Bei unsachgemäßem Einsatz können Gefahren von ihm ausgehen.

Das Gerät **darf nur von qualifiziertem und autorisiertem Fachpersonal** unter strenger Beachtung dieser Betriebsanleitung, der einschlägigen Normen, der gesetzlichen Vorschriften und der Zertifikate (je nach Anwendung) eingebaut, angeschlossen, in Betrieb genommen und gewartet werden.

->  XA 148F

Sicherheitshinweise in XA 148F beachten!

#### **e Notes on Safety**

The Nivotester FTL 375 N may only be used as a measuring transmitter power supply for limit switches with two-wire NAMUR signals.

If used incorrectly it is possible that application-related dangers may arise.

The level limit device may be installed, connected, commissioned, operated and maintained **by qualified and authorised personnel only**, under strict observance of these operating instructions, any relevant standards, legal requirements, and, where appropriate, the certificate.

->  XA 148F

Note the safety instructions in XA 148F!

#### **f Conseils de sécurité**

Le Nivotester FTL 375 N doit exclusivement être utilisé comme alimentation de transmetteur pour détecteurs de niveau avec signal NAMUR 2 fils.

Il peut être source de danger en cas d'utilisation non conforme aux prescriptions.

L'appareil ne doit être installé, raccordé, mis en service et maintenu **que par un personnel qualifié et autorisé**, qui tiendra compte des indications contenues dans la présente mise en service, des normes en vigueur et des certificats disponibles (selon l'application).

->  XA 148F

Tenir compte des conseils de sécurité dans XA 148F!

## es Notas sobre seguridad

El Nivotester FTL 375 N debe utilizarse únicamente como fuente de alimentación de detectores de nivel con señales NAMUR de dos hilos.

Su empleo inapropiado puede resultar peligroso.

El equipo deberá ser montado, conectado, instalado y mantenido única y **exclusivamente por personal cualificado y autorizado**, bajo rigurosa observación de las presentes instrucciones de servicio, de las normativas y legislaciones vigentes, así como de los certificados (dependiendo de la aplicación)

->  XA 148F

Notas sobre seguridad  
en XA 148F!

## i Note sulla sicurezza

Il Nivotester FTL 375 N può essere usato solo per alimentare sensori in tecnologia NAMUR.

Un'installazione non corretta può determinare pericolo.

Lo strumento FTL 375 N deve essere montato, connesso, messo in funzione ed operato

**solamente da personale qualificato ed autorizzato**, sotto la stretta osservazione delle presenti norme di installazione e di manutenzione e delle ulteriori norme, regolamenti, disposizioni legali e, dove richiesto, dei certificati appropriati.

->  XA 148F

Vedere istruzioni di sicurezza  
in XA 148F!

## nl Veiligheidsinstructies

De niveautester FTL 375 N mag alleen als meetversterker/voeding voor niveauschakelaars met 2-draads NAMUR signalen, worden gebruikt.

Indien niet correct gebruikt kunnen gevaarlijke situaties ontstaan.

Het instrument alleen door **gekwalificeerd en geautoriseerd personeel** laten inbouwen, aansluiten, in bedrijf nemen en onderhouden.

Neem de instructies in deze Inbedrijfstellingsvoorschriften de desbetreffende normen, de wettelijke voorschriften en eventuele certificaten in acht.

->  XA 148F

Veiligheidsinstructies  
XA 148F in acht nemen!

- d** Geräte-Identifikation
- e** Device Identification
- f** Désignation de l'appareil
- es** Identificación del equipo
- i** Identificazione dello strumento
- nl** Instrument-identificatie

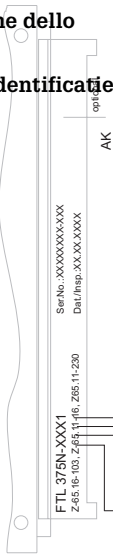

F = ATEX II (1) GD, [EEx ia] IIC

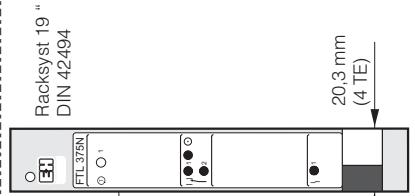

1  
9 = ...

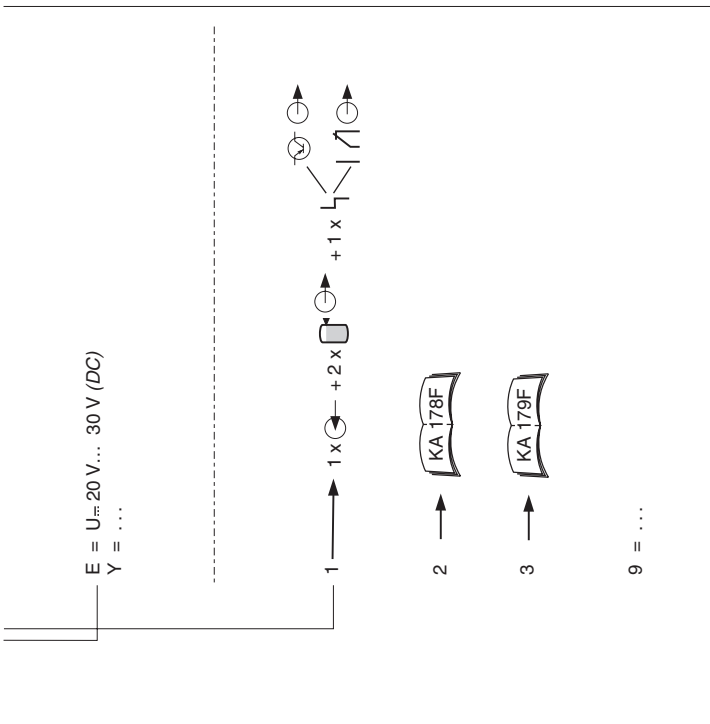

= Ausgang / Output / Sortie / Salida / Uscita / Uitgang

= Eingang / Input / Entrée / Acceso / Ingresso / Ingang

= Grenzsinal / Limit signal / Signal de seuil / Soglia d'intervento / Señal de límite / Niveausignaal

= Störung / Fault / Défaut / Fallo / Guasto / Storing

. . . = andere / others / autres / otros / altri / andere

- d** Messeinrichtung
- e** Measuring system
- f** Ensemble de mesure
- es** Sistema de medida
- i** Sistema di misura
- nl** Meetopstelling

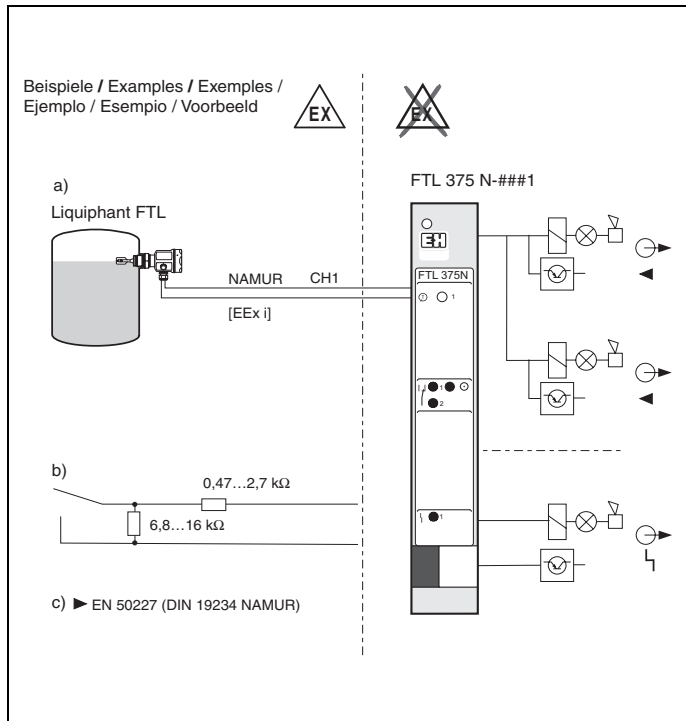



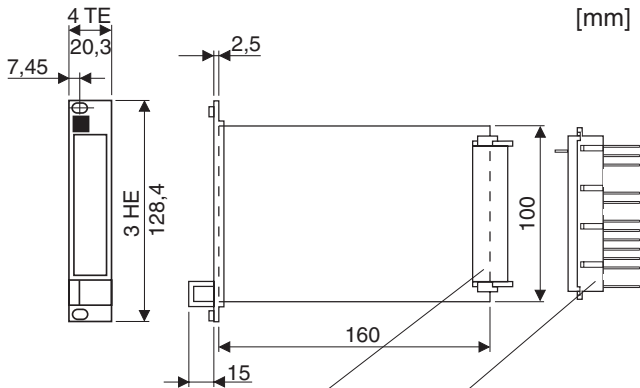

- |           |                     |  |
|-----------|---------------------|--|
| <b>d</b>  | Messerleiste        | Federleiste mit Codierstiften            |
| <b>e</b>  | Male connector      | Female connector with coding pins        |
| <b>f</b>  | Connecteur mâle     | Connecteur femelle avec détrompeurs      |
| <b>es</b> | Conector macho      | Conector hembra con pins de codificación |
| <b>i</b>  | Morsettiera maschio | Morsettiera femmina codificata           |
| <b>nl</b> | Connector           | Connector met codeerpennen               |

DIN 41612/3/F

**d Einbau**  
in Baugruppenträger  
(Feldgehäuse) oder  
Monorack II-Gehäuse

**e Installation**  
in subrack (field housing) or  
Monorack II housing

**f Montage**  
dans un rack  
(boîtier de terrain) ou  
un boîtier Monorack II

**es Montaje**  
en rack (versión de campo) o  
caja Monorack II

**i Montaggio**  
in cestello Rack oppure  
in Monorack II  
(custodia da campo)

**nl Inbouw**  
in 19" rack of Monorack II  
behuizing

100 mm = 3.94 in

**d** Codierstifte in die Federleiste stecken, Position 2+19

**e** Insert coding pins in pos. 2+19 of the female connector

**f** Emplacement des détrompeurs dans le connecteur femelle, pos. 2+19

**es** Insertar pins de codificación en pos. 2+19 del conector hembra

**i** Inserire i pin di codifica nelle pos. 2+19 della morsettiere femmina

**nl** Codeerpennen in de connector plaatsen, pos. 2+14

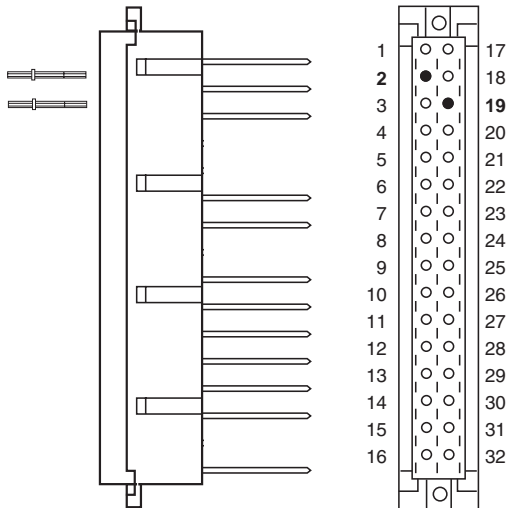

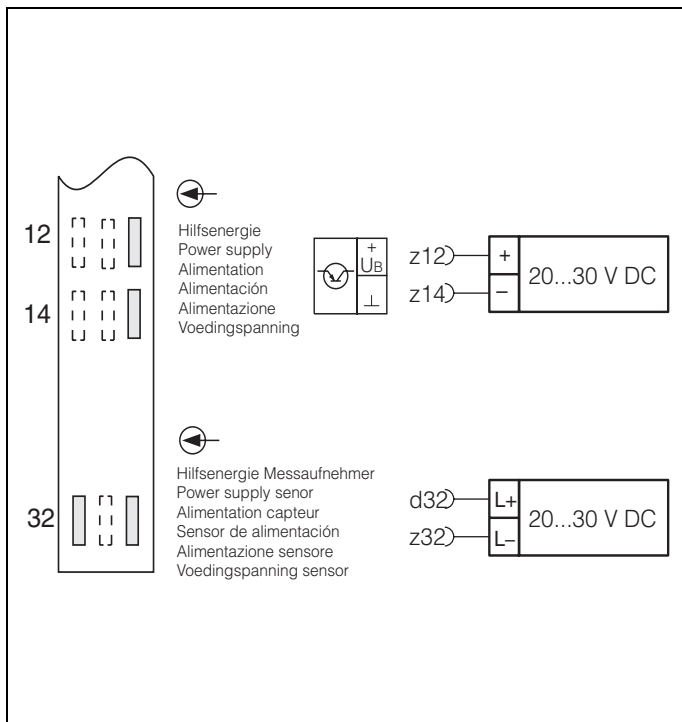

**d Anschluss**  
Hilfsenergie  
Federleiste Anschlussseite

**e Connection**  
Power Supply  
Connection side of the  
female connector

**f Raccordement**  
Alimentation  
Connecteur femelle,  
coté raccordement

**es Conexiones**  
Alimentación  
Conector hembra,  
lado de conexión

**i Collegamenti**  
Alimentazione  
Morsettiere femmina,  
parte connessioni

**nl Aansluiting**  
Voedingspanning  
Aansluitzijde van de  
connector

- d** Anschluss des  
Messaufnehmers
- e** Sensor connection
- f** Raccordement du capteur
- es** Conexión de sensor
- i** Connessione sensore
- nl** Aansluiting van de sensor

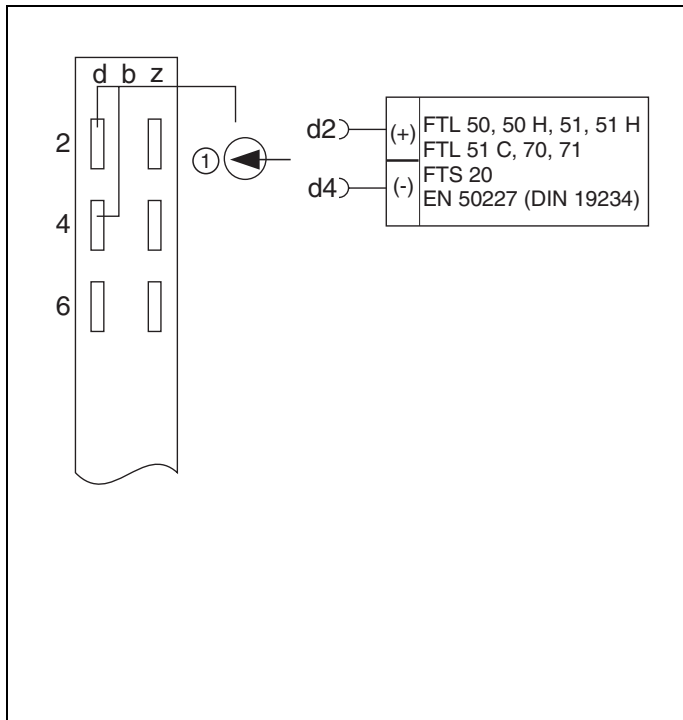

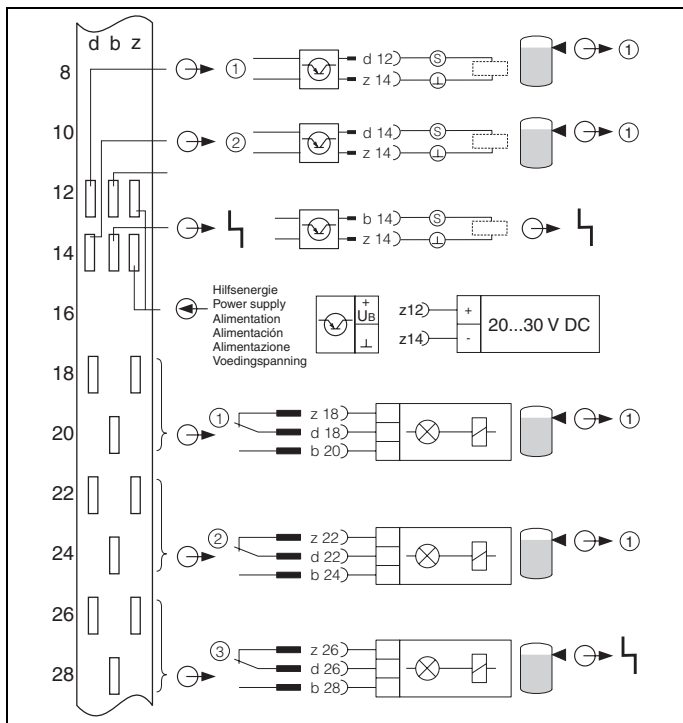

**d Einstellungen**

Fehlerstromsignal einstellen  
Alarm ON / OFF

**e Setting-up**

Set error current signal  
Alarm ON / OFF

**f Réglages**

Réglage du signal courant  
défaut  
Alarme ON / OFF

**es Ajuste**

Ajustar señal de error de  
alimentación  
Alarma ON / OFF

**i Messa in marcia**

Impostazione segnale  
d'allarme  
Allarme ON / OFF

**nl Instellingen**

Foutstroom instellen  
Alarm ON / OFF

High ↔ Low / 2,1 ↔ 1,2

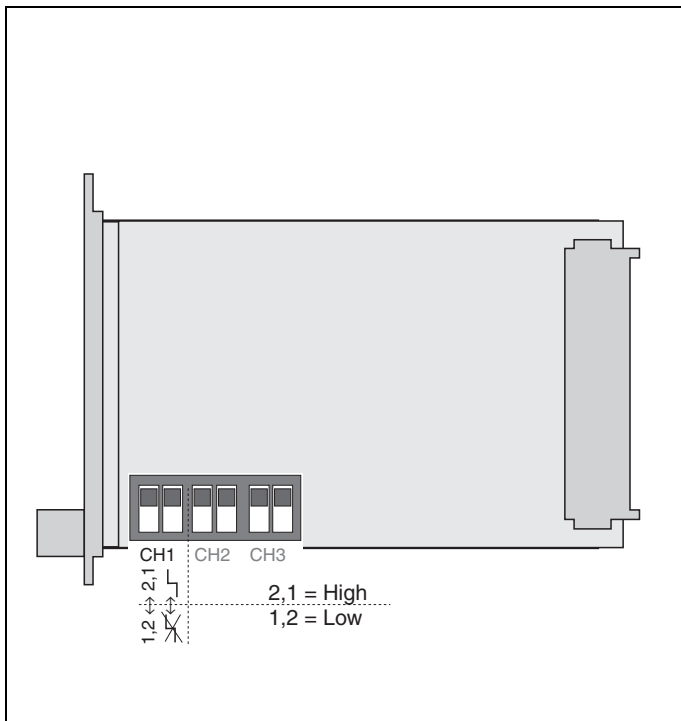

**d** Erläuterungen:

### **Grenzsignalfunktion**

(Seite 14):

Die Einstellungen können beliebig High (2,1) oder Low (1,2) gesetzt sein (je nach Anforderung).

### **Störungsmeldung $\perp$**

Die Wahl zwischen Störungsmeldung  $\perp$  und keine Störungsmeldung  $\nexists$  ist für jeden einzelnen Kanal möglich. Bei Störung an einem Eingang fallen das zu diesem Eingang gehörende Ausgangsrelais und das Störungsmelderelais ab.

Wird als Eingangssignal nur ein einfacher Schalter genutzt (z.B. ein Schwimmschalter), so müssen die DIP-Schalter für die Störungsmeldesignale zu diesem Kanal OFF gesetzt werden.

Wird als Eingangssignal ein einfacher Schalter (z.B. Schwimmschalter) mit zusätzlicher Widerstandschaltung genutzt - wie auf Seite 8 + 9 im Fall b) dargestellt -, kann der DIP-Schalter für das Störungsmeldesignal am entsprechenden Kanal ON gesetzt werden. Dies hat zur Folge, dass die Leitung zwischen Schalter und Trennschaltverstärker auf Leitungsunterbruch und Kurzschluss überwacht wird.

### **Einstellungen bei den E+H Elektronikeinsätzen FEL 58 und FEL 56**

Je nach Einbaulage des Liquiphant M/S ist die MIN- oder MAX- Einstellung am Elektronikeinsatz FEL 58 od. FEL 56 vorzunehmen. Zusätzlich muß am Nivotester das Fehlerstromsignal gewählt werden, damit die Grenzwertrelais sicherheitsgerichtet schalten.

FEL 58 = < 1,2 mA = Low

FEL 56 = > 2,1 mA = High



**e** Explanations:

**Limit signal function**

(Page 14):

You can set the settings to High (2,1) or Low (1,2) as you wish (depending on requirements).

**Alarm** 

You can choose between alarm  and no alarm  for each individual channel. In the case of a fault at an input, the output and alarm relays for this input drop out.

If a simple switch is used as an input signal (e.g. a floating switch), the DIP switches for the alarm signal must be set to OFF for this channel.

If a simple switch (e.g. float switch) with additional resistor circuit is used as an input signal – as shown on pages 8 + 9 in case b) -, the DIP switch can be set to ON for the alarm signal at the corresponding channel. This results in the line between switch and isolator amplifier being monitored for line interruptions and short-circuits.

**Settings for the E+H electronic inserts FEL 58 and FEL 56**

The MIN or MAX setting on the electronic insert FEL 58 or FEL 56 must be made according to the orientation of the Liquiphant M/S. In addition, the error current signal at the Nivotester must be selected, so that the limit relays switch in such a way that safety requirements are met.

FEL 58 = < 1,2 mA = Low

FEL 56 = > 2,1 mA = High



**f** Explications:

### **Fonction signal de seuil**

(p. 14):

Les réglages peuvent être au choix High (2,1) ou Low (1,2) (selon les besoins).

#### **Message alarme $\lrcorner$**

Le choix entre message alarme  $\lrcorner$  et pas de message alarme  $\nmid$  est possible pour chaque voie. Lors d'un défaut à une entrée, le relais de sortie affecté à cette entrée et le relais alarme retombent.

Si un commutateur simple (par ex. flotteur) est utilisé comme signal d'entrée, il faut que les micro-commutateurs pour les signaux défaut soient réglés sur OFF pour cette voie.

S'il convient malgré tout de surveiller une alarme, il est possible de régler le micro-commutateur pour le signal défaut sur ON pour la voie concernée. De plus il faut réaliser dans ce cas pour l'entrée un circuit de résistance comme décrit à la page 8, cas b).

#### **Réglages pour les électroniques E+H FEL 58 et FEL 56**

Les réglages (MIN/MAX) pour les électroniques FEL 58 et FEL 56 du Liquiphant exercent une influence sur les relais de sortie du FTL 375 N. Selon la position du micro-commutateur, le courant est High ou Low. Les électroniques FEL 58 et FEL 56 se comportent en opposition, c'est à dire MIN FEL 56 = MAX FEL 58.

**es** Explicaciones:

### **Función señal de límite**

(Página 14):

Puede configurarse como High (2,1) o Low (1,2) según se requiera.

### **Alarma** $\hookcorner$

Posibilidad de seleccionar alarma  $\hookcorner$  o no alarma  $\nmid$  para cada canal individual. En caso de fallo en una entrada, los relés de salida y alarma de esta entrada se desactivan.

Si un solo interruptor se utiliza como señal de entrada (por ej. un flotador), los interruptores DIP de la señal de alarma deben estar en OFF en este canal.

Si es necesario controlar una alarma, el interruptor DIP para la señal de alarma pueden ponerse en ON en el canal apropiado. También en este caso, debe haber un circuito de resistencia para la entrada, como se muestra en el caso b) en página 8.

### **Ajustes para las electrónicas E+H FEL 58 y FEL 56**

Los ajustes (MIN/MAX) para las electrónicas FEL 58 y FEL 56 de Liquiphant, influyen en los relés de salida del FTL 375 N. La corriente de control es High o Low dependiendo de la posición del interruptor DIP.

Las electrónicas FEL 58 y FEL 56 se comportan como opuestas, ej. MIN FEL 56 = MAX FEL 58.

**i** Spiegazioni:

**Soglia ON/OFF**

(pagina 14):

E' possibile impostare a piacimento al valore High (2,1) o Low (1,2) (secondo le necessità).

**Allarme**  $\hookrightarrow$

E' possibile scegliere tra allarme  $\hookrightarrow$  e no allarme  $\nrightarrow$  per ciascun canale, in caso di malfunzionamento ad un ingresso, l'uscita e i relè di allarme per questo ingresso si deenergizzano.

Se viene utilizzato come ingresso di segnale un semplice interruttore ad esempio un interruttore a galleggiante, il DIP switches per il l'impostazione dell'allarme di questo canale, deve essere posto su OFF.

Se deve essere monitorato un allarme in ogni caso, il DIP switch per il segnale d'allarme può essere impostato su ON per l'appropriato canale. Anche in questo caso il circuito resistivo deve essere come mostrato nel caso b) a pag. 8.

**Impostazione per inserti elettronici E+H FEL 58 e FEL 56**

L'impostazione (MIN/MAX) per l'inserto elettronico FEL 58 e FEL 56, influenza le uscite a relè del FTL 375 N. La corrente di controllo è High o Low in funzione della posizione del DIP switch.

L'impostazione degli inserti FEL 58 e FEL 56 è in opposizione esempio MIN FEL 56 = MAX FEL 58.

**nl** Verklaring:

### **Niveausignaal functie**

(Pagina 14):

De instellingen kunnen naar keuze als High (2,1) of Low (1,2) ingesteld worden (afhankelijk van de toepassing).

### **Storingsmelding $\perp$**

De keuze tussen storingsmelding  $\perp$  en geen storingsmelding  $\lambda$  is per kanaal mogelijk. Bij storing aan een ingang vallen het, bij deze ingang behorende, uitgangsrelais en het storingsmeldrelais af.

Indien als ingangssignaal een eenvoudige schakelaar gebruikt wordt (bijv. een vlotterschakelaar) dan moet de dip-schakelaar voor het storingsmeldsignaal voor dit kanaal op OFF gezet worden.

Moet echter dit alarmsignaal toch bewaakt worden, dan kan de dip-schakelaar op ON gezet worden.

Er moet dan echter wel een weerstandschakeling op de ingang aangesloten worden zoals aangegeven op pagina 8, situatie b).

### **Instellingen bij de E+H elektronica-units FEL 58 en FEL 56**

De instellingen (min./max.) bij de elektronica-units FEL 58 en FEL 56 voor de Liquiphant beïnvloeden het uitgangsrelais van de FTL 375 N. Afhankelijk van de instelling van de dip-schakelaars is de stroom High of Low.

De elektronica-units FEL 58 en FEL 56 reageren precies omgekeerd, d.w.z. min. FEL 56 = max. FEL 58.

Gelbe Leuchtdiode  
"Relais Ausgang angezogen."

Yellow LED  
"Output relay picked-up."

DEL jaune  
"Relais de sortie attiré."

LED amarillo  
"Relé de salida activado."

LED giallo  
"Di stato dei relè."

Gele LED  
"Relais uitgang aangetrokken"

Rote Leuchtdiode: "Störung"

Red LED: "Fault"

DEL rouge : "Défaut"

LED rojo: "Fallo"

LED rosso: "di allarme"

Rode LED: "Storing"

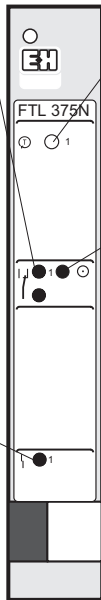

Prüftaste  
Test button  
Touche test  
Botón de prueba  
Pulsante di test  
Testtoet

Grüne Leuchtdiode  
"Betrieb"

Green LED  
"on"

DEL verte  
"on"

LED verde  
"iluminado"

LED verde  
"di funzionamento"

Groene LED  
"in bedrijf"

**d** Bedien- und  
Anzeigeelemente

**e** User interface elements

**f** Eléments d'affichage  
et de commande

**es** Elementos de indicación  
y función

**i** Elementi sul frontale

**nl** Bedienings- en  
aanwijzelementen

**d Funktion****e Function****f Fonctionnement****es Funcionamiento****i Funzione****nl Functie**

Maximum-Sicherheitschaltung  
 Maximum fail-safe mode  
 Sécurité maximum  
 Conmutador de seguridad máx.  
 Selezione della modalità di  
 sicurezza max.  
 Maximum veiligheidsschakeling



→ FEL 58: Low 1,2  
 → FEL 56: High 2,1



Schalterstellung / Switch position / Position commutateur / Posición conmutador / Posizione commutatore / Schakel positie		FEL58: MAX MIN	FEL56: MAX MIN	GN = green RD = red YE = yellow	
Füllstand Level Niveau Nivel Livello Niveau					YE YE RD
	 	 			YE YE RD
	 	 			YE YE RD
Störung Fault Défaut Fallo Guasto Storing  0...0,4 mA 6,0...8,6 mA	  	  	 		YE YE RD
0 V	  	 			YE YE RD

Schalterstellung / Switch position / Position commutateur / Posición conmutador / Posizione commutatore / Schakel positie		FEL58: MIN	MAX MIN	GN = green RD = red YE = yellow	
Füllstand Level Niveau Nivel Livello Niveau					YE YE RD
	 	 			YE YE RD
	 	 			YE YE RD
Störung Fault Défaut Fallo Guasto Storing  0...0,4 mA 6,0...8,6 mA	 	 			YE YE RD
0V	 	 			YE YE RD







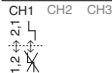











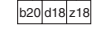
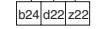
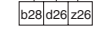



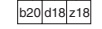
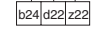
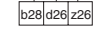



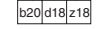
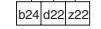
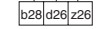





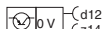
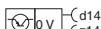



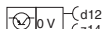
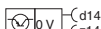



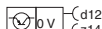
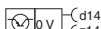













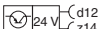
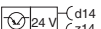
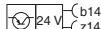



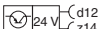
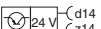
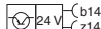



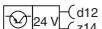
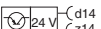
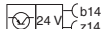





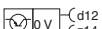
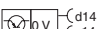
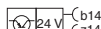

Minimum-Sicherheitschaltung  
Minimum fail-safe mode  
Sécurité minimum  
Commutador de seguridad mín.  
Selezione della modalità di  
sicurezza min.  
Minimum veiligheidschakeling

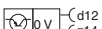
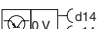
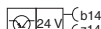

→ FEL 58: Low 1,2  
→ FEL 56: High 2,1

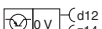
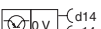
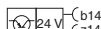

- d** Schaltereingang
- e** Switch input
- f** Entrée commutateur
- es** Entrada interruptor
- i** Ingresso interruttore
- nl** Schakelingang

Füllstand Level Niveau Nivel Livello Niveau					YE  GN YE RD
 	     	     	     	YE  GN YE  GN RD 	
 	  	     	     	YE  GN YE  GN RD 	
Füllstand Level Niveau Nivel Livello Niveau					YE  GN YE RD
 	     	     	     	YE  GN YE  GN RD 	
 	  	     	     	YE  GN YE  GN RD 	



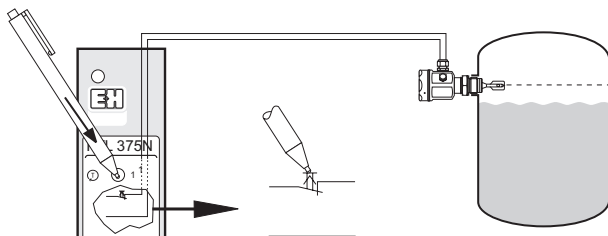









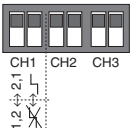

- d** Zur Überprüfung der Funktion von Messaufnehmer und FTL 375 N wird durch Betätigung des Testtasters die Versorgung zum Messaufnehmer unterbrochen.
- e** To check the function of the measuring transmitter and the FTL 375 N, press the test key to interrupt the power supply to the measuring sensor.
- f** Pour contrôler le fonctionnement du capteur et du FTL 375 N, on interrompt l'alimentation du capteur en activant la touche test.
- es** Para comprobar el Funcionamiento del detector y del FTL 375 N, accione el botón de prueba para interrumpir la alimentación al detector.
- i** Per verificare la funzionalita' del trasmettitore FTL 375 N premere il pulsante di test per interrompere l'alimentazione del sensore.
- nl** Voor het testen van de functie van de sensor en de FTL 375 N wordt door het indrukken van de testknop de voedingsspanning naar de sensor onderbroken.

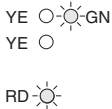
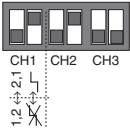
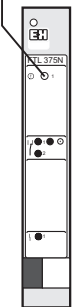
- d** Weitere Erläuterungen
- e** Further explanations
- f** Autres explications
- es** Más información
- i** Altre spiegazioni
- nl** Meer informatie

Liquiphant M,  
FTL 50 (H) / 51 (H), 51 C  
Liquiphant S  
FTL 70/71

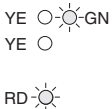
<p>Bei Einstellung With setting Avec réglage Con ajuste Con impostazione Met instelling</p>	<p>Prüftaste drücken Press test button Appuyer sur la touche test</p>	 ► CH1 ► CH2		
	<p>Pulse el botón de prueba Premere il pulsante test Testknop indrukken</p>	 	 	
		 	 	

**d Funktionstest**

der Messeinrichtung

Mit Meßaufnehmer:

- Liquiphant M,  
FTL 50 (H) / 51 (H) ,51 C
- Liquiphant S FTL 70/71

Störmeldung = EIN

Die Prüftaste des FTL 375 N drücken.

→ Relais fällt ab.

→ Rote Störungs-LED leuchtet.

Die Prüftaste des FTL 375 N loslassen.

Rückkehr zum normalen Betrieb.

**e Function test**

of the measuring system

With measuring transmitter:

- Liquiphant M,  
FTL 50 (H) / 51 (H), 51 C
- Liquiphant S FTL 70/71

Alarm signal = ON

Press the test key on the FTL 375 N.

→ Relay drops out.

→ Red fault LED is lit.

Release the test key on the FTL 375 N.

Return to normal mode.

**f Test de fonctionnement**

de l'ensemble de mesure

Avec capteur:

- Liquiphant M,  
FTL 50 (H) / 51 (H), 51 C
- Liquiphant S FTL 70/71

Message d'alarme = ON

Activer la touche-test du FTL 375 N.

→ Relais retombe.

→ DEL rouge défaut s'allume.

Relâcher la touche-test.

Retour au mode normal.

**es Prueba de funcionamiento**

del sistema de medición

Con los detectores:

- Liquiphant M,  
FTL 50 (H) / 51 (H), 51 C
- Liquiphant S FTL 70/71

Señal de alarma = ON.

Presione el botón de prueba del FTL 375 N.

→ El relé se desactiva.

→ El relé de fallo rojo se ilumina.

Deje de presionar el botón de prueba del FTL 375 N.

Retorno a modo normal.

**i Test di funzionalità**

del sistema con sensori

Con sensori:

- Liquiphant M,  
FTL 50 (H) / 51 (H), 51 C
- Liquiphant S FTL 70/71

Segnale d'allarme = ON

Premere il pulsante del FTL 375 N.

→ Relè deenergizzato.

→ LED rosso acceso  
rilasciare il pulsante.

Rilasciare il pulsante.

Ritorno al modo normale.

**nl Functietest**

van het meetsysteem

Met sensor:

- Liquiphant M,  
FTL 50 (H) / 51 (H), 51 C
- Liquiphant S FTL 70/71

Storingsmelding = Aan

De testkop van de FTL 375 N indrukken.

→ Relais valt af.

→ Rode storings LED  
licht op.

De testknop van de FTL 375 N loslaten.

Terug naar normaal bedrijf.

**d Technische Daten**

Hilfsenergie für FTL 375 N  
und Transistorausgänge:  
20...30 V DC  
Restwelligkeit: max. 2 V

Schaltleistung

Relaiskontakte:

- $U_{\sim}$  max. 253 V
- $I_{\sim}$  max. 2,5 A
- $P_{\sim}$  max. 600 VA/cos  $\varphi = 1$
- $P_{\sim}$  max. 300 VA/cos  $\varphi \geq 0,7$

–  $U_{-}$  max. 100 V

–  $I_{-}$  max. 2,5 A

–  $P_{-}$  max. 100 W

Bei gleichzeitigem Anschluss  
an Funktionskleinspannungs-  
stromkreis mit sicherer

Trennung:

max. 50 V AC, 2,5 A

Transistorausgänge:

- Ausgang high:  
typisch 24 V/500 mA
- Ausgang low: < 100 mV
- kurzschlussfest

**e Technical Data**

Power supply for FTL 375 N  
and transistor outputs:  
20...30 V DC  
Residual ripple: max. 2 V

Relay contact switching  
capacity:

- $U_{\sim}$  max. 253 V
- $I_{\sim}$  max. 2,5 A
- $P_{\sim}$  max. 600 VA/cos  $\varphi = 1$
- $P_{\sim}$  max. 300 VA/cos  $\varphi \geq 0,7$

–  $U_{-}$  max. 100 V

–  $I_{-}$  max. 2,5 A

–  $P_{-}$  max. 100 W

When simultaneously  
connected to low-voltage  
function circuit with safe  
disconnection:

max. 50 V AC, 2,5 A

Transistor outputs:

- Output high:  
typ. 24 V/500 mA
- Output low: < 100 mV
- short-circuit-proof

**f Caractéristiques techniques**

Alimentation pour FTL 375 N  
et sorties transistor :  
20...30 V DC  
Ondulation résiduelle : max. 2 V

Puissance de coupure des  
contacts de relais :

- $U_{\sim}$  max. 253 V
- $I_{\sim}$  max. 2,5 A
- $P_{\sim}$  max. 600 VA/cos  $\varphi = 1$
- $P_{\sim}$  max. 300 VA/cos  $\varphi \geq 0,7$

–  $U_{-}$  max. 100 V

–  $I_{-}$  max. 2,5 A

–  $P_{-}$  max. 100 W

En cas de raccordement  
simultané à un circuit faible  
tension avec mise hors circuit :  
max. 50 V AC, 2,5 A

Sorties transistor :

- Sortie max. :  
typ. 24 V/500 mA
- Sortie min. : < 100 mV
- résistance aux court-circuits

**es Datos técnicos**

Tensión de alimentación para FTL 375 N y salidas de transistor: 20...30 V DC  
Rizado residual: máx. 2 V

Capacidad conexión contacto de relé:

- $U_{\sim}$  máx. 253 V
- $I_{\sim}$  máx. 2,5 A
- $P_{\sim}$  máx. 600 VA/cos  $\varphi = 1$
- $P_{\sim}$  máx. 300 VA/cos  $\varphi \geq 0,7$

- $U_{-}$  máx. 100 V
- $I_{-}$  máx. 2,5 A
- $P_{-}$  máx. 100 W

Si se conecta simultáneamente al circuito de función de bajo voltaje con desconexión segura: máx. 50 V AC, 2,5 A

Salidas transistor:

- Salida alta:  
Típica 24 V/500 mA
- Salida baja: < 100 mV
- Prueba cortocircuito

**i Dati tecnici**

Alimentazione per FTL 375 N e uscite a transistore:  
20...30 V DC  
Ripple residuo: max. 2 V

Capacità di commutazione dei contatti relé:

- $U_{\sim}$  max. 253 V
- $I_{\sim}$  max. 2,5 A
- $P_{\sim}$  max. 600 VA/cos  $\varphi = 1$
- $P_{\sim}$  max. 300 VA/cos  $\varphi \geq 0,7$

- $U_{-}$  max. 100 V
- $I_{-}$  max. 2,5 A
- $P_{-}$  max. 100 W

Quando connessi simultaneamente a un circuito di bassa tensione di sicurezza: máx. 50 V AC, 2,5 A

Uscite transistore:

- Uscita alta:  
tipico 24 V/500 mA
- Uscita bassa: < 100 mV
- protezione cortocircuito

**nl Technische gegevens**

Voeding voor FTL 375 N en transistor uitgangen:  
20...30 V DC  
Restrimpel: max. 2 V

Schakelvermogen van de relaiscontacten:

- $U_{\sim}$  max. 253 V
- $I_{\sim}$  max. 2,5 A
- $P_{\sim}$  max. 600 VA/cos  $\varphi = 1$
- $P_{\sim}$  max. 300 VA/cos  $\varphi \geq 0,7$

- $U_{-}$  max. 100 V
- $I_{-}$  max. 2,5 A
- $P_{-}$  max. 100 W

Indien gelijktijdig verbonden met een laagspanningscircuit met een veilige scheiding: máx. 50 V AC, 2,5 A

Transistor uitgangen:

- uitgang hoog:  
typisch 24 V/500 mA
- uitgang laag: < 100 mV
- kortsluitveilig

<b>Fehlfunktion</b>	<b>Ursache</b>	<b>Maßnahme</b>
Schaltet nicht	Versorgungsspannung fehlt (Grüne Leuchtdiode aus)	Versorgung prüfen
	Elektronik defekt	FTL 375 P austauschen
	Kontakte verschweißt (nach einem Kurzschluss)	FTL 375 P austauschen; Sicherung in den Kontaktstromkreis
	Messaufnehmer defekt	Messaufnehmer austauschen
Schaltet falsch	DIP-Schalter für Grenzsinal falsch eingestellt	DIP-Schalter auf der Platine richtig einstellen (S. 14)
Dauernde Störungsmeldung	Unterbrechung oder Kurzschluss der Leitung zum Messaufnehmer	Leitung überprüfen
	Messaufnehmer-Elektronik defekt	Messaufnehmer-Elektronik austauschen

**e** **Trouble-shooting**

<b>Fault</b>	<b>Reason</b>	<b>Remedy</b>
Does not switch	No power (green LED does not light up)	Check power
	Electronic defect	Replace FTL 375 N
	Contacts welded together (after short-circuit)	Replace FTL 375 N; connect a fuse into contactor circuit
	Measuring transmitter defective	Replace measuring transmitter
Switches incorrectly	Incorrect setting of DIP switch for limit signal	Set DIP switch to correct setting on pcb (p. 14)
Permanent alarm signal	Interrupt or short-circuit line to measuring transmitter	Check line
	Measuring transmitter electronics defective	Replace measuring transmitter electronics



Défaut	Cause	Mesure
Ne commute pas	Absence tension d'alimentation (diode verte éteinte)	Vérifier l'alimentation
	Electronique défectueuse	Remplacer le FTL 375 N
	Contacts soudés (après un court- circuit)	Remplacer le FTL 375 N; insérer un fusible dans le circuit du contact
	Capteur défectueux	Remplacer le capteur
Mauvaise commutation	Mauvais réglage du micro-commutateur pour le signal de seuil	Régler correctement le micro-commutateur sur le circuit imprimé (p. 14)
Message alarme permanent	Interruption ou court-circuit de la liaison au capteur	Vérifier la liaison
	Electronique du capteur défectueuse	Remplacer l'électronique du capteur

**es Identificación de fallos**

<b>Fallo</b>	<b>Causa</b>	<b>Solución</b>
No conmuta	No hay alimentación (el LED verde no está iluminado)	Compruebe la alimentación
	Las electrónicas son defectuosas	Sustituya el FTL 375 N
	Contactos soldados juntos (después del corto circuito)	Sustituya el FTL 375 N; conecte un fusible en el circuito contactor
	Sensor defectuoso	Cambie el sensor
Conmuta incorrectamente	Posición incorrecta del conmutador para la señal de límite	Cambie la posición del conmutador en la electrónica (pág. 14)
Aviso de fallo constante	Interrupción o cortocircuito de la conexión con el sensor	Compruebe el cableado
	Electrónicas del transmisor defectuosas	Sustituya la electrónica del transmisor

<b>Guasto</b>	<b>Motivo</b>	<b>Rimedio</b>
Non commuta	Manca alimentazione (LED verde spento)	Controllare l'alimentazione
	Elettronica difettosa	Sostituire FTL 375 N
	Contatti saldati insieme (dopo il corto circuito)	Sostituire FTL 375 N; inserire un fusibile nel circuito dei contatti
	Dispositivo guasto	Sostituire il dispositivo
Commuta non correttamente	Errata impostazione del DIP switch per la soglia	Impostare correttamente il DIP vedere pag. 14
Rimane in allarme	Linea interrotta o in corto circuito	Verificare la linea
	Elettronica guasta	Sostituire l'elettronica

## **i Individuazione e eliminazione delle anomalie**

<b>Fout</b>	<b>Oorzaak</b>	<b>Maatregel</b>
Schakelt niet	Voeding ontbreekt (groene LED uit)	Voeding testen
	Elektronica defect	FTL 375 N uitwisselen
	Contacten verkleefd (na een kortsluiting)	FTL 375 N uitwisselen; zekering plaatsen in contactcircuit
	Sensor defect	Sensor verwisselen
Schakelt foutief	Niet correcte instelling van de dip-schakelaar voor het niveausignaal	Stel dip-schakelaar correct in (pag. 14)
Continue foutmelding	Onderbreking of signaal kortsluiting van de sensorbekabeling	Kabel testen
	Sensor elektronica defect	Sensor elektronica verwisselen

<b>d</b>	Technische Information für Nivotester FTL 375 N	TI 361F
<b>e</b>	Technical Information for Nivotester FTL 375 N	TI 361F
<b>f</b>	Information technique Nivotester FTL 375 N	TI 361F
<b>es</b>	Información técnica sobre Nivotester FTL 375 N	TI 361F
<b>i</b>	Informazioni tecniche per Nivotester FTL 375 N	TI 361F
<b>nl</b>	Technische Informatie voor Nivotester FTL 375 N	TI 361F

Internet-Download: [www.endress.com](http://www.endress.com)

<b>d</b>	Sicherheitshinweise (ATEX)
<b>e</b>	Safety instructions (ATEX)
<b>f</b>	Conseils de sécurité (ATEX)
<b>es</b>	Instrucciones de seguridad (ATEX)
<b>i</b>	Istruzioni di sicurezza (ATEX)
<b>nl</b>	Veiligheidsinstructies (ATEX)

XA 148F **CE**  II (1) GD, [EEx ia] IIC

<b>d</b>	<b>Ergänzende Dokumentation</b>
<b>e</b>	<b>Supplementary Documentation</b>
<b>f</b>	<b>Documentation complémentaire</b>
<b>es</b>	<b>Documentación adicional</b>
<b>i</b>	<b>Documentazione supplementare</b>
<b>nl</b>	<b>Aanvullende documentatie</b>





---

**Endress+Hauser Sales Center****AT** Tel. (01) 88056-0, Fax (01) 88056-35**BE** Tel. (02) 2480600, Fax (02) 2480553**CAN** Tel. (905) 6819292, Fax (905) 6819444**CH** Tel. (061) 7157575, Fax (061) 7111650**DE** Tel. (07621) 97501, Fax (07621) 975555**DK** Tel. (70) 131132, Fax (70) 132133**ES** Tel. (93) 4803366, Fax (93) 4733839**FR** Tel. (389) 696768, Fax (389) 694802**GB** Tel. (0161) 2865000, Fax (0161) 9981841**HK** Tel. 25283120, Fax 28654171**IT** Tel. (02) 92192-1, Fax (02) 92192-362**JP** Tel. (0422) 540613, Fax (0422) 550275**MAL** Tel. (03) 7334848, Fax (03) 7338800**NO** Tel. (032) 859850, Fax (032) 859851**NL** Tel. (035) 6958611, Fax (035) 6958825**SE** Tel. (08) 55511600, Fax (08) 55511655**SF** Tel. (09) 8676740, Fax (09) 86767440**SGP** Tel. 5668222, Fax 5666848**THA** Tel. (2) 9967811-20, Fax (2) 9967810**USA** Tel. (317) 5357138, Fax (317) 5358498**ZA** Tel. (011) 2628000, Fax(011) 262806**INTERNATIONAL** Tel. + Fax: see DE  
<http://www.endress.com> 11.00/PTS-D

52010895