

Level Limit Switch *nivotester FTL 375 N*

**1-, 2- and 3-channel isolating switching amplifier
with NAMUR input for connection to any NAMUR
measuring cell**

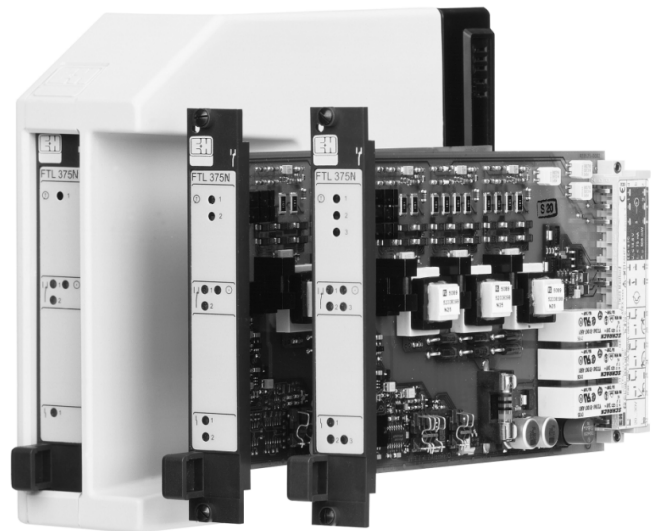

Applications

- Level limit detection in fluid tanks, including those in potentially hazardous areas
- For measuring cells in Zone 0 or Zone 20
- Fluid detection in pipes for pump dry running protection
- Overspill protection for tanks containing flammable or non-flammable fluids hazardous to water
- Two-point control and level limit detection in one switching unit

Your benefit

- Nivotester FTL 375 N for connecting one, two or three measuring cells (1-channel, 2-channel or 3-channel devices).
- Intrinsically safe signal circuits [EEx ia] for installing measuring cells in potentially hazardous areas.

- High functional safety thanks to:
 - Line monitoring through to sensor
 - Monitoring for corrosion on tuning forks of Liquiphant M and Liquiphant S (HT) measuring cells
- Racksyst plug-in card in Europa card format to DIN 41494, 4 HP wide, 3 HU high
- Same device for mounting either in 19" assembly rack or single Monorack housing for 1-channel and 2-channel devices
- Intensive quality control measures: from isolating amplifier through to measuring cell
- Inputs are galvanically isolated from each other, from the mains and from the outputs
- Additional binary outputs
- NAMUR interface complying with EN 50227 (DIN 19234; NAMUR) or IEC 60947-5-6 for the connection of NAMUR measuring cells or electronic inserts.

Endress + Hauser

The Power of Know How



Function and system design

Measuring principle

Signal transmission

The intrinsically safe input of the Nivotester FTL 375 N limit switch is galvanically isolated from the mains and from the output.

The Nivotester supplies direct current to the Liquiphant M and Liquiphant S (high temperature) with FEL 56 and 58 electronic insert or a sensor specified in accordance with EN 50227 (DIN 19234, NAMUR) or IEC 60947-5-6 specified sensors via a two-wire cable with DC. A control current is simultaneously transmitted on this supply line.

The control current range is between < 1.2 mA and > 2.1 mA depending on the switching state.

Signal evaluation

The Nivotester evaluates the control current and switches the output relay for the level alarm.

At the same time the binary output transistor, which is parallel to the relay, switches.

The switching state of the relay is displayed on the front panel of the Nivotester by means of a yellow light emitting diode.

Fail-safe circuit

Selecting the "Maximum / Minimum" fail-safe circuit on the electronic insert (FEL 58 or FEL 56) and the correct selection of the fault current signal (< 1.2 mA for the FEL 58 / > 2.1 mA for the FEL 56) on the Nivotester ensures that the output relay and the transistor outputs always operate safely in quiescent current.

- Maximum safety: The relay drops out or the transistor output is disabled when the switch point is exceeded (measuring cell covered), a fault occurs or the line voltage fails.
- Minimum safety: The relay drops out or the transistor output is disabled when the switch point is undershot (measuring cell uncovered), a fault occurs or the line voltage fails.

Function monitoring

To increase operational safety the Nivotester is equipped with a function monitoring facility.

A fault is indicated by a red LED and disables the relay for the level alarm and binary output for the channel involved. In addition, a fault is always signalled via a separate binary output. A fault is reported if the Nivotester is no longer receiving a control signal. For example, this occurs if there is a short-circuit or interruption in the signal line to the measuring cell, corrosion on the tuning fork of a measuring cell or a defect in the Nivotester input circuit. Function monitoring can be implemented on each channel by pressing the test button. During this process, power supply is interrupted to the sensor.

Two-point control (Δs)

The 2-channel and 3-channel Nivotesters can carry out two-point control in a tank (e.g. to control a pump). The switching hysteresis is defined by the mounting location of the two measuring cells.

NAMUR module

The FTL 375 N includes a NAMUR interface complying with EN 50227 (DIN 19234; NAMUR) or IEC 60947-5-6. This means that control signals generated by the measuring cell in accordance with the NAMUR recommendation can be analysed by the Nivotester FTL 375 N.

The following Endress+Hauser level limit switches are specified and may be connected in accordance with EN 50227 (DIN 19234; NAMUR) or IEC 60947-5-6:

- LIQUIPHANT M with FEL 56
- LIQUIPHANT M with FEL 58
- LIQUIPHANT S (high temperature) with FEL 56
- LIQUIPHANT S (high temperature) with FEL 58

In addition sensors specified in accordance with EN 50227 (DIN 19234; NAMUR) or IEC 60947-5-6, as well as contact switches with the appropriate resistance circuit may be connected.

Where contact switches are used without the resistance circuit, the alarm detection for short circuit or open circuit on the signal line can be switched off for the channel concerned.

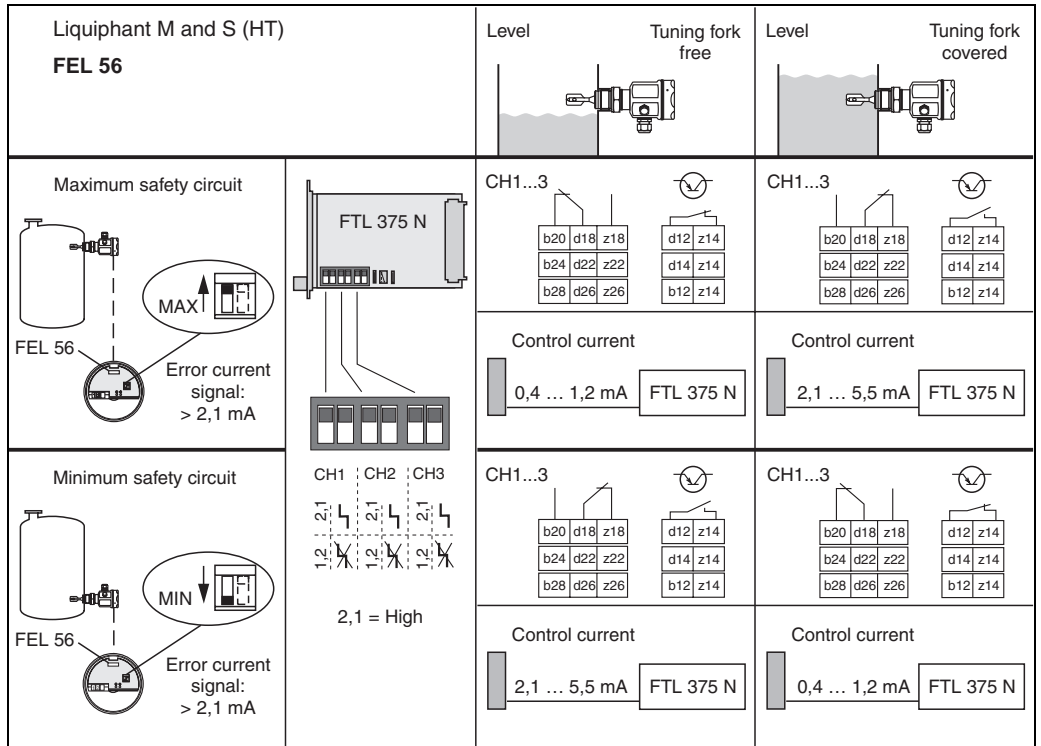

L00-FTL375Nx-15-06-xx-en-001

Function of limit signal and current signal depending on level and fail-safe circuit.

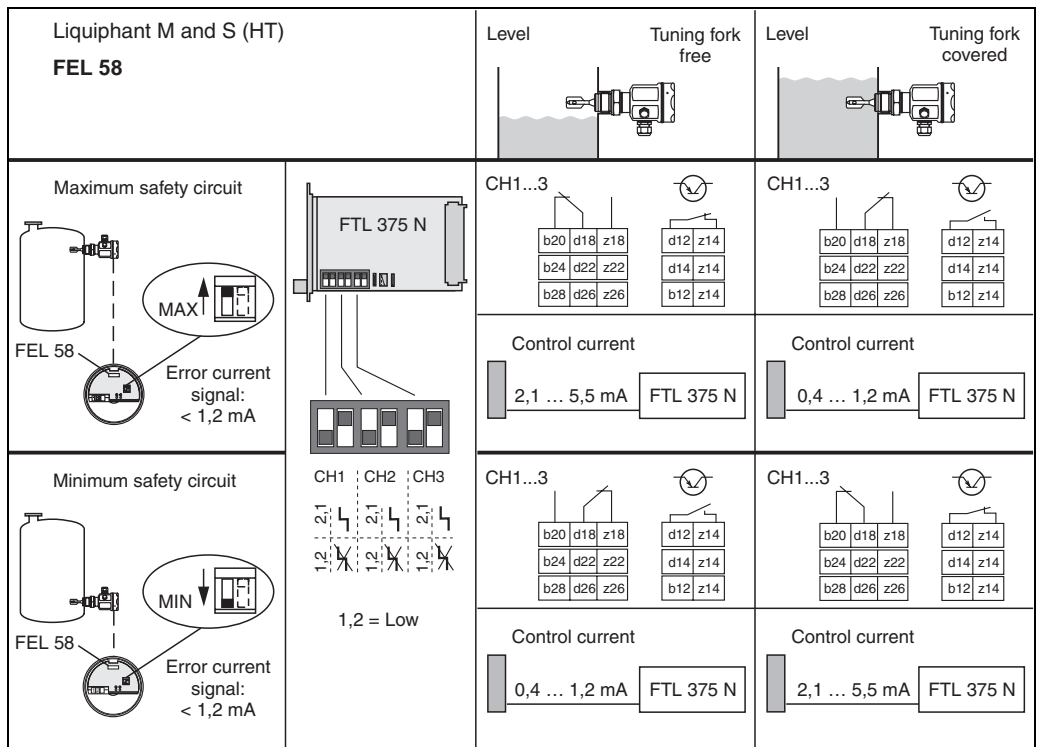

L00-FTL375Nx-15-06-xx-en-002

Function of limit signal and current signal depending on level and fail-safe circuit.

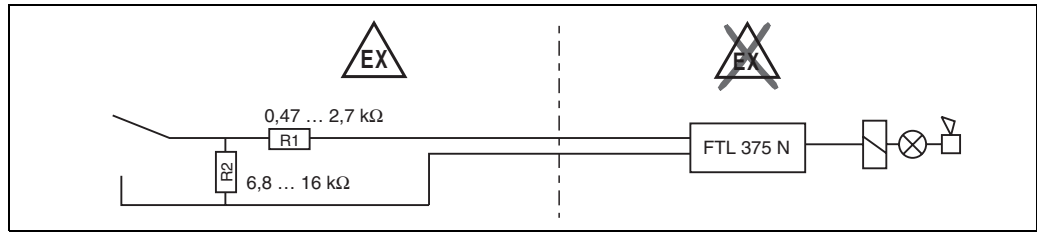

L00-FTL375Nx-14-06-xx-xx-001

Contact switches with appropriate resistance circuit.

Simplified function test for Liquiphant M and Liquiphant S (HT)

Regular function checks are stipulated for overspill protection features. The Nivotester and downstream plant sections can be equipped with a function test which does not require the sensor to be addressed or removed. The Nivotester is fitted with a test button for each signal input on the front panel for this purpose. The power supply is interrupted when the test button is pressed. When this button is released again, power is returned to the Liquiphant with FEL 56 or FEL 58 and it is ready for operation after a brief settling time.

Further information regarding the function test may be found in the brief operating instructions: KA 177F, KA 178F, KA 179F.

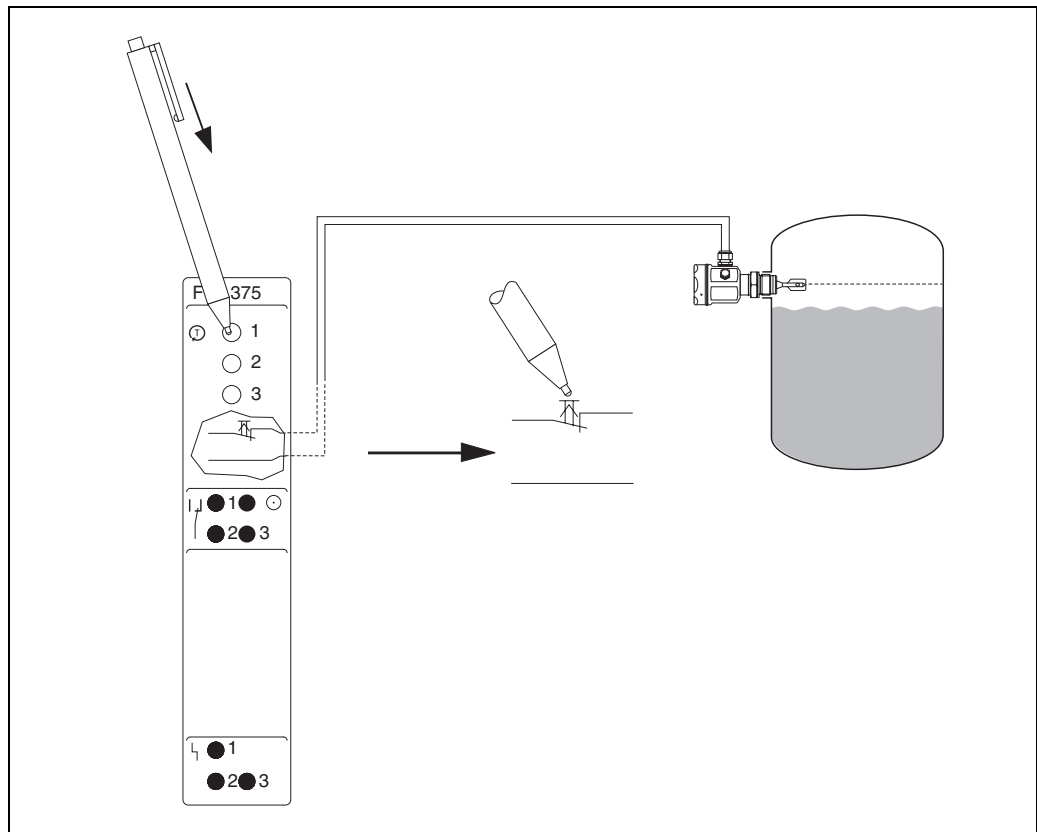

L00-FTL375xx-19-06-xx-xx-001

Measuring device

A simple measuring device consists of 1 to 3 measuring cells, a 1-, 2- or 3-channel Nivotester and control or signalling devices. Liquiphant M or Liquiphant S (high temperature - HT) can be used as the measuring cell.

1-channel Nivotester FTL 375 N-###1

The measuring device of the single-channel device comprises:

- 1 measuring cell
- 1-channel Nivotester
- Control or signalling devices

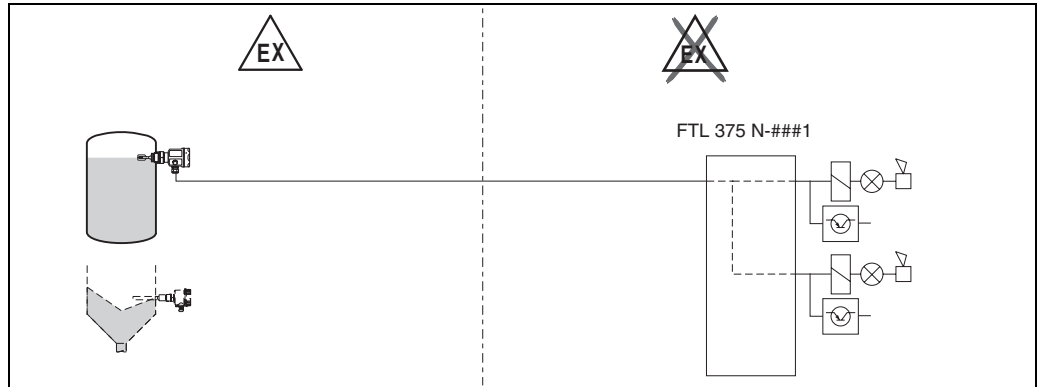

L00-FTL375Nx-14-06-xxx-xx-002

2-channel Nivotester FTL 375 N-###2

The measuring device of the two-channel device comprises:

- 2 measuring cells
- 2-channel Nivotester
- Control or signalling devices

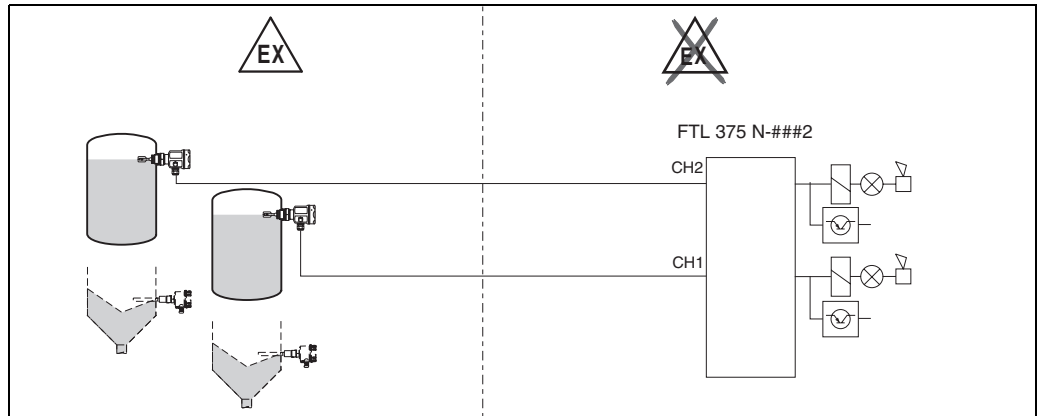

L00-FTL375Nx-14-06-xxx-xx-003

3-channel Nivotester FTL 375 N-###3

There are five possible variants of the measuring device for the three-channel device. If all 3 channels are used for limit measurement, the measuring device comprises:

- 3 measuring cells
- 3-channel Nivotester
- Control or signalling devices

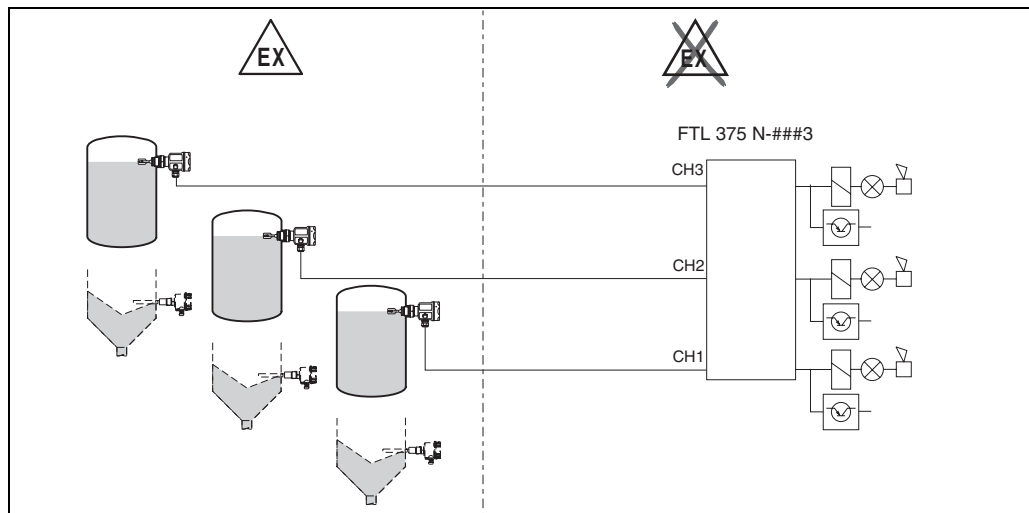

L00-FTL375Nx-14-06-xx-xx-004

Two-point control Δ s with 2- or 3-channel Nivotester FTL 375 N-###2 or FTL 375 N-###3

If the CH1 and CH2 channels are used for two-point control Δ s on the 2- and 3-channel devices, the measuring device comprises:

- 2 measuring cells
- 2-channel or 3-channel Nivotester
- Control or signalling devices

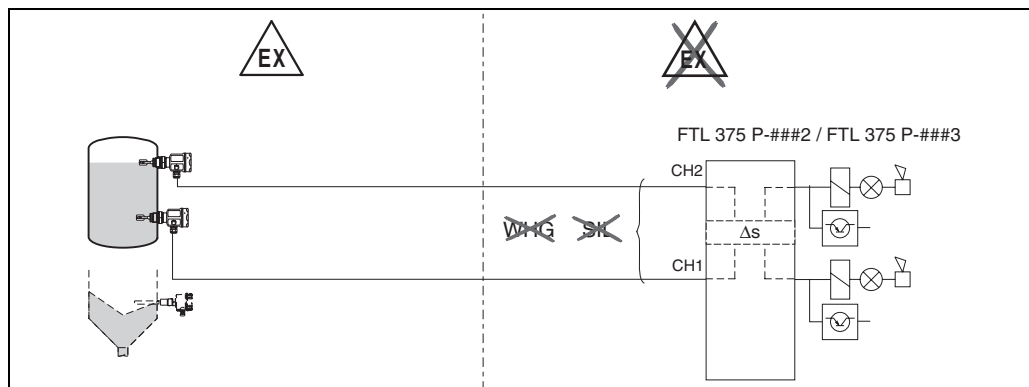

L00-FTL375Nx-14-06-xx-xx-005

Control variants for 3-channel Nivotester FTL 375 N-###3

1. If the CH1 and CH2 channels are used for two-point control Δs and the CH3 channel for overspill protection, the measuring device comprises:
 - 3 measuring cells
 - 3-channel Nivotester
 - Control or signalling devices

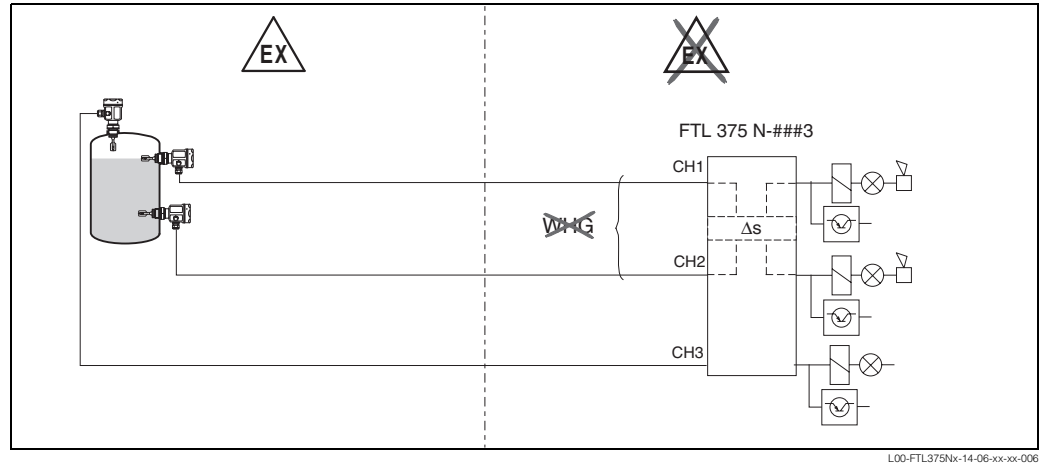

2. If the CH1 channel is used for level measurement with 2 limit relays and the CH3 channel for further limit measurement, the measuring device comprises:
 - 2 measuring cells
 - 3-channel Nivotester
 - Control or signalling devices

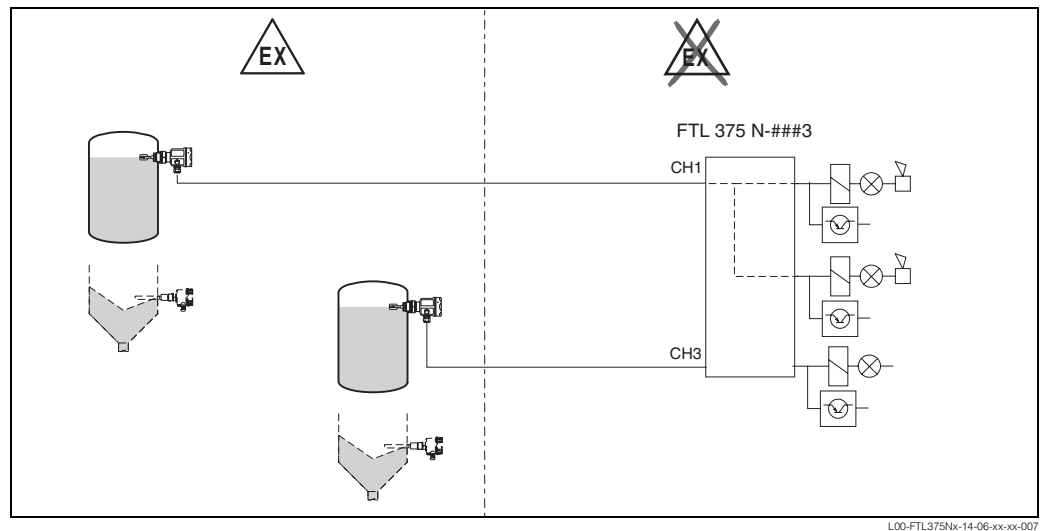

3. If the CH1 channel is used for level measurement with 2 limit relays, the measuring device comprises:
- 1 measuring cell
 - 3-channel Nivotester
 - Control or signalling devices

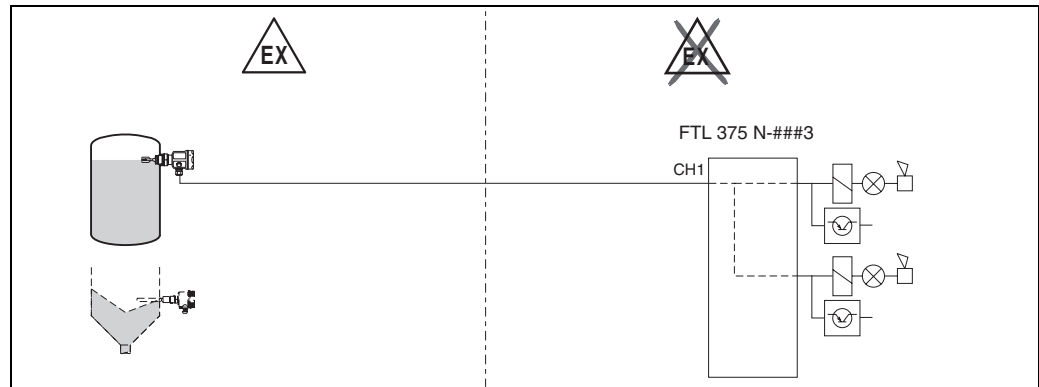

Input parameters

| | |
|--------------------------|---|
| Measured variable | The limit signal is generated at minimum or maximum level, depending on the selection |
| Measuring range | The measuring range is dependent on the mounting location of the sensors |
| Input signal | <ul style="list-style-type: none"> • FTL 375 N input: galvanically isolated from power supply and output • Type of protection: intrinsic safety [EEx ia] IIC • Connectable measuring cells: <ul style="list-style-type: none"> – Liquiphant M FTL 50/51, FTL 50 H/51 H, FTL 51 C with electronic insert FEL 56 or FEL 58 – Liquiphant S (HT) FTL 70/71 with electronic insert FEL 56 or FEL 58 – Any sensor certified to EN 50227 (DIN 19234; NAMUR) or IEC 60947-5-6 certified sensors – Contact switch with appropriate resistance circuit • Power supply of measuring cells: by Nivotester FTL 375 N • Connecting line: wire pair, screening not required • Line resistance: max. 25 Ω per wire • Signal transmission: current signal on supply line • Control current range: < 1.2 mA / > 2.1 mA |

Further information on the user of the measuring cells in non-hazardous areas may be found in the relevant certificates.

Output parameters

| | |
|---|---|
| Output signal | <p>1-channel device:</p> <ul style="list-style-type: none"> • 2 relay outputs for a single channel (potential-free changeover contact for level alarm), two transistor outputs (transistor with galvanic isolation) <p>2-channel device:</p> <ul style="list-style-type: none"> • 2 relay outputs for two single channels (potential-free changeover contact for level alarm), two transistor outputs (transistor with galvanic isolation) <p>3-channel device:</p> <ul style="list-style-type: none"> • 3 relay outputs for three single channels (potential-free changeover contact for level alarm), three transistor outputs (transistor with galvanic isolation) <p>For all devices:</p> <ul style="list-style-type: none"> • Quiescent current fail-safe circuit: minimum/maximum safety selectable (note fault current signal!) • Switching delay: approx. 0.5 s • Switching power of relay contacts: <ul style="list-style-type: none"> U~ max. 253 V I~ max. 2.5 A P~ max. 600 VA bei $\cos \varphi = 1$ P~ max. 300 VA bei $\cos \varphi \geq 0.7$ <p>U– max. 100 V I– max. 2.5 A P– max. 100 W</p> <p>When simultaneously connected to low-voltage circuit with protected isolation: max. 50 V AC, 2.5 A</p> <ul style="list-style-type: none"> • Life: min. 10^5 switching cycles at maximum contact load • Common fault output: Binary output (transistor with galvanic isolation) Input range of external power supply for binary outputs: 20...30 V DC Permissible residual ripple within tolerance: $U_{ss} = \text{max. } 2 \text{ V}$ Voltage at output signal high: typ. 24 V DC (depending on external power supply between 20...30 V DC) Voltage at output signal low: < 100 mV Max. current at output signal high: 500 mA short-circuit proof • Function indicators: LEDs for operation, level alarm and error |
| Overvoltage category as per EN 61010 | II |
| Protection class | II (double or increased isolation) |
| Signal on alarm | Limit relay dropped-out; fault message by means of red LEDs, Alarm relay dropped-out for FTL 375 N-###1, FTL 375 N-###2 and optionally for FTL 375 N-###3 Binary outputs disabled at limit value, binary outputs disabled on alarm |
| Galvanic isolation | All input and output channels and relay contacts are galvanically isolated from each other |

Power supply

Electrical connection

Male multipoint connector

Plug-in connector as per DIN 41612, Part 3, design F

Use of measuring cell in potentially hazardous areas

Compliance with the national explosion protection regulations for the design and laying of intrinsically safe signal line is mandatory.

Maximum permissible values for capacitance and inductance may be found in the Safety Instructions XA 148F.

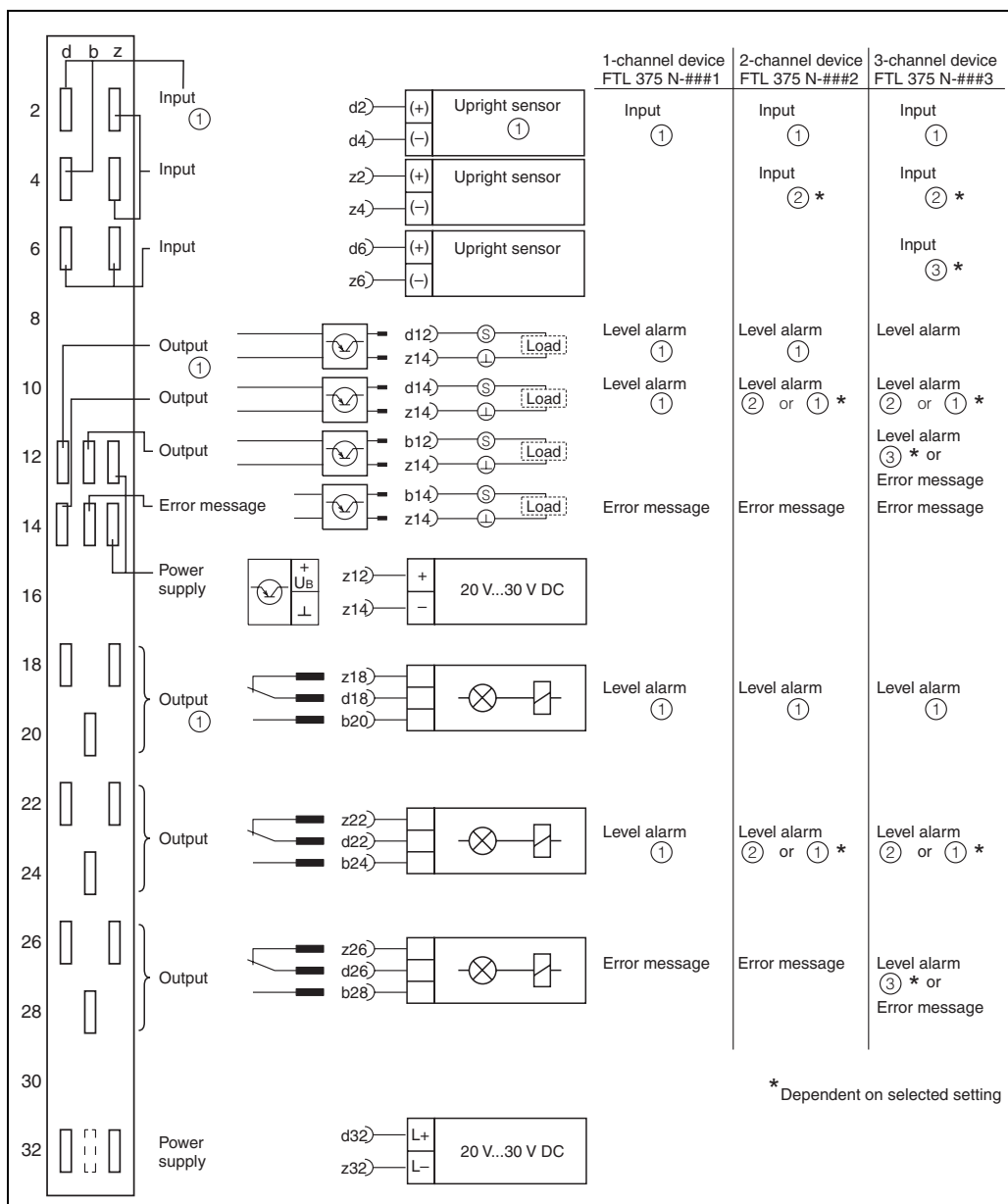

L00-FTL375Nx-11-06-xx-en-001

Supply voltage

Direct current version (DC):

- Voltage range: 20...30 V
- DC supply: max. 53 mA (1-channel)
- DC supply: max. 65 mA (2-channel)
- DC supply: max. 80 mA (3-channel)
- Permissible residual ripple within tolerance: $U_{ss} = \text{max. } 2 \text{ V}$

| | |
|--------------------------|---|
| Power consumption | 1-channel: max. 1.59 W (at U_{\max} 30 V) |
| | 2-channel: max. 1.95 W (at U_{\max} 30 V) |
| | 3-channel: max. 2.40 W (at U_{\max} 30 V) |

Accuracy

| | |
|-----------------------------|---|
| Settling time/period | Final switching state after switching on power supply: approx. 2 s, dependent on measuring cell connected |
|-----------------------------|---|

Operating conditions (installation conditions)

Installation instructions

Installation location

The Nivotester FTL 375 N Racksyst plug-in card must be installed in an assembly rack or in a protective housing outside the hazardous area.
The following options are available:

- 19" assembly rack for mounting in control room for max. 21 plug-in cards (max 10 plug-in cards if all terminals are assigned).
For more information, see TI 224F (Part No.: 017279-1000).
- 1/2-19" Racksyst field housing in degree of protection IP65 for a maximum 10 plug-in cards (max. 3 plug-in cards if all terminals are assigned).
For more information, see TI 026F.
- Monorack II housing for 4 HP plug-in cards in degree of protection IP40 for mounting of 1- or 2-channel devices singly or in banks.
For more information, see BA 090F (Part No.: 016046-0000).
- For mounting the Monorack housing outdoors, there is a protective housing IP55 available.
For more information, see TI 099F (Part No.: 015140-0000).



L00-FTL375N-11-06-xxxx-001

Orientation

Vertical in assembly rack.

Operating conditions (environmental conditions)

| | |
|--|---|
| Installation location | Assembly rack for control room or protective housing for outdoor installation. |
| Permissible ambient temperatures | <p>Nominal operating range</p> <ul style="list-style-type: none"> • $-20\text{ °C} \dots +70\text{ °C}$ <p>Storage temperature</p> <ul style="list-style-type: none"> • $-25\text{ °C} \dots +85\text{ °C}$ (preferably at $+20\text{ °C}$) <p>Restrictions of ambient temperature when mounting in assembly rack (Racksyst II) and Monorack, see Supplementary Documentation.</p> |
| | <p> Caution! The devices should be installed in locations which are protected from direct solar radiation, weather and impacts. This is of particular importance in hot climates.</p> |
| Climatic and mechanical application class | <p>3K3 In acc. with DIN EN 60721-3-3</p> <p>3M2 In acc. with DIN EN 60721-3-3</p> |
| Degree of protection | Plug-in card IP00, front panel IP20 |
| Electromagnetic compatibility (EMC) | <p>Interference emission to EN 61326; Electrical Equipment Class B</p> <p>Interference immunity to EN 61326; Annex A (Industrial) and NAMUR Recommendation NE 21 (EMC)</p> |

Mechanical construction

Design, dimensions

- Racksyst plug-in card to DIN 41494, t = 160 mm, h = 100 mm (Europa card format)
- Front panel made of black plastic with inserted blue field and handle with labelling strip
- Width: 4 modular units (20.3 mm); height: 3 height units (128.4 mm)
Connection with male multipoint connector to DIN 41612, Part 3, design F, reduced 16-pin configuration for Monorack II (Racksyst II)
- Coding holes in male multipoint connector,
FTL 375 N-###1: Pos. 2 and 19;
FTL 375 N-###2: Pos. 2 and 20;
FTL 375 N-###3: Pos. 2 and 21



Note!
100 mm = 3.94 in

Dimensions

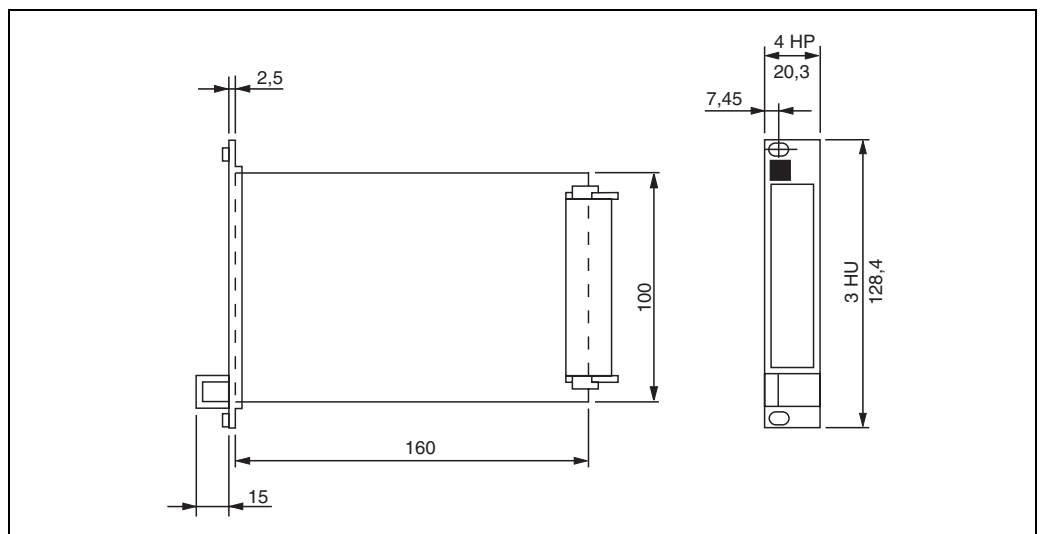

Dimensions of Eurocard format

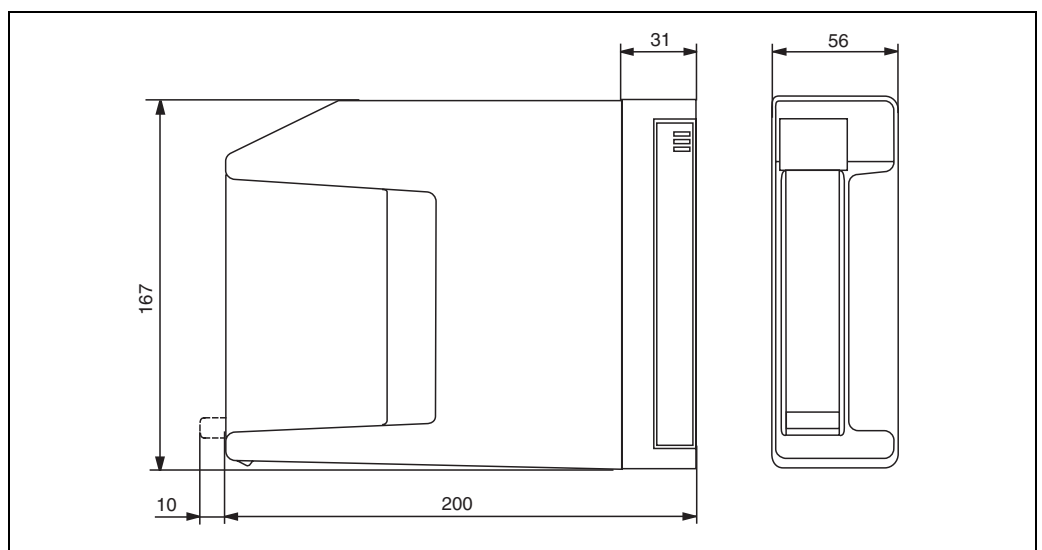

Dimensions of Monorack

- Weight**
- 1-channel: approx. 134 g
 - 2-channel: approx. 146 g
 - 3-channel: approx. 158 g

Materials **Front panel**

Black plastic with blue field insert and grip with labelling strip

Male multipoint connector Electrical connections see page 10.
 Arrangement of coding pin in female multipoint connector of Nivotester 1-channel, 2-channel and 3-channel devices:

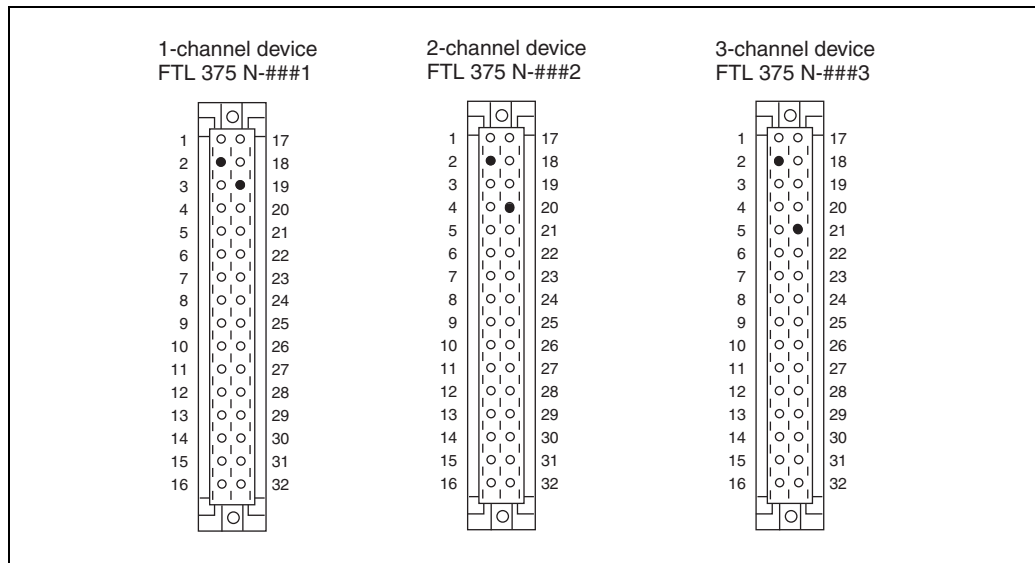

L00-FTL375Nx-04-06-xx-en-001

User interface

Operating concept On-site configuration with hook and DIP switches on the board

- Display elements**
- Green LED: standby
 - Red LED per channel: alarm
 - Yellow LED per channel: limit relay picked-up or transistor conductive

Operating elements

- 1 DIL switch for fault current signal (< 1.2 mA / > 2.1 mA)
- 1 DIL switch for alarm ON/OFF
- 2 Hook switch for Δs function
- 3 Hook switch for relay 3 or fault output
- 4 Hook switch for channel 1 and/or channel 2
- 5 Test button for each channel

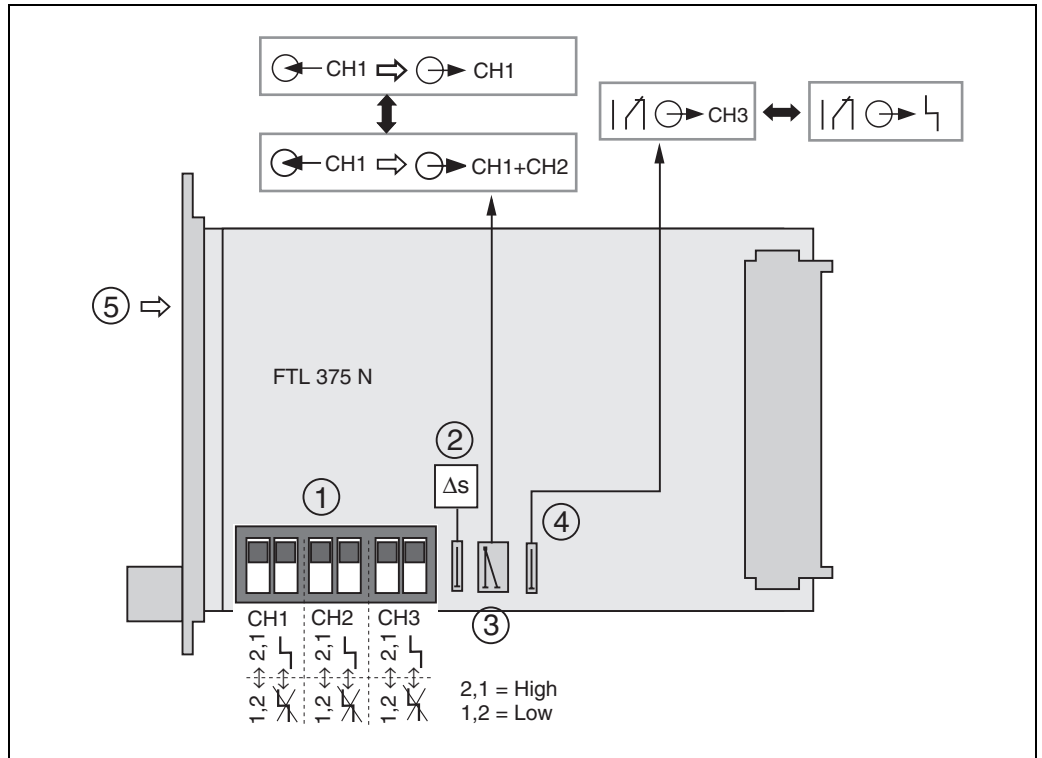

L00-FTL375Nx-19-06-xxx-xx-002

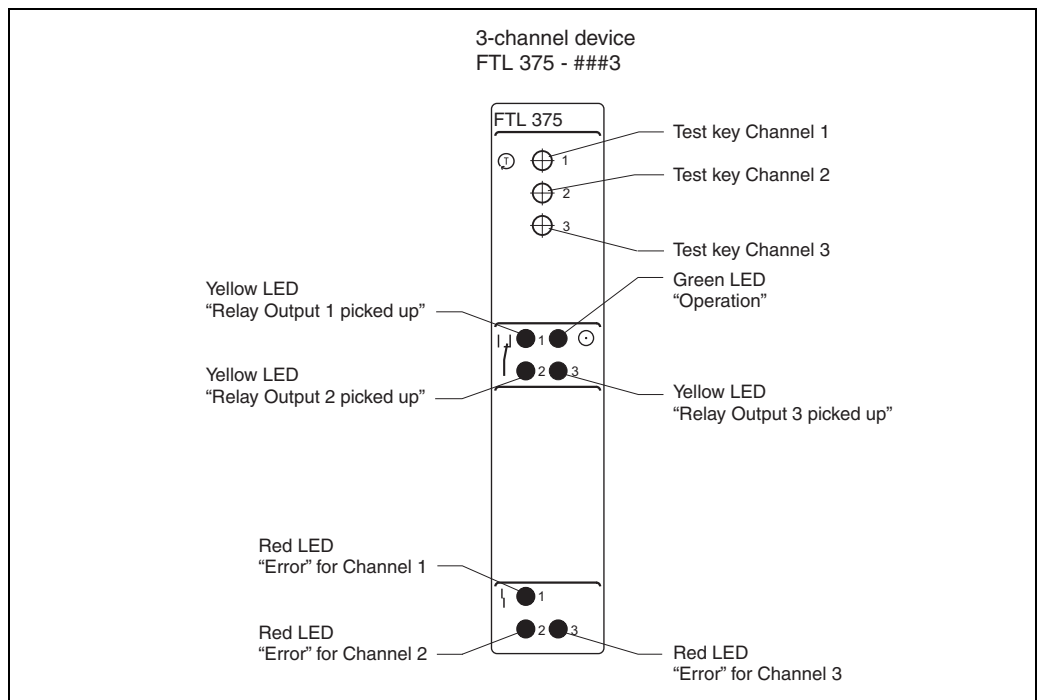

L00-FTL375xx-19-06-xx-en-001

Certificates and approvals

| | |
|---|--|
| CE mark | The Nivotester meets all the statutory requirements arising from EC directives. Endress+Hauser confirms the successful testing of the device by affixing the CE mark. |
| Ex approval | The Endress+Hauser Sales Centre will provide you with information on the current availability of versions for use in hazardous areas (ATEX [EEx ia]). All the relevant data for explosion protection is contained in separate Ex documentation (see Supplementary Documentation) which you can request. |
| Type of protection | [EEx ia] IIC |
| Overspill protection | WHG |
| External standards and regulations | <p>External standards and regulations which were complied with during the conception and development of Nivotester FTL 375 N.</p> <ul style="list-style-type: none"> • EN 50227 (DIN 19234; NAMUR) or IEC 60947-5-6 Interface (limit level) in accordance with the NAMUR recommendation • EN 60529 Degrees of protection through housing (IP code) • EN 61010 Safety regulations for electrical control and instrumentation devices and laboratory instruments • EN 61326 Interference emission (Electrical Equipment Class B), Interference immunity (Annex A - Industrial) • EN 50020 Electrical apparatus for potentially hazardous areas (intrinsic safety "i") • EN 50014 Electrical apparatus for potentially hazardous areas (general conditions) |

Ordering information

Nivotester FTL 375 N

| | | | |
|-----------|---------------------|---|-------------------------------|
| 10 | Certificates | F | ATEX II (1) GD [EEx ia] IIC |
| 20 | Version | 1 | Eurocard format, 4 HP wide |
| | | 9 | Special version |
| 30 | Power supply | E | Power supply 20... 30 V DC |
| | | Y | Special version |
| 40 | Output | 1 | 1x level SPDT + 1x alarm SPDT |
| | | 2 | 2x level SPDT + 1x alarm SPDT |
| | | 3 | 3x level SPDT |
| | | 9 | Special version |
| FTL 375 N | | | Complete product name |

Accessories

Protective housing

- Monorack II (4 HP) (for 1- and 2-channel devices)
- Monorack protective housing
- Racksyst assembly rack
- Racksyst field housing

Further particulars see page 11: Installation instructions

- Female multipoint connector for FTL 375 N-###1/2/3 (plug-in point installation kit 24/2)
24S: Part No. 52012443
24W: Part No. 52012444

Supplementary Documentation

System Information (SI)

- Racksyst system overview
SI 008F/00/en
- Liquiphant M
SI 040F/00/en

Technical Information (TI)

- Liquiphant M
FTL 50/51, FTL 50 H/51 H
Measuring cell for level limit detection in fluids
TI 328F/00/en
- Liquiphant M
FTL 51 C
Measuring cell for level limit detection in fluids
with highly corrosion-resistant coating
TI 347F/00/en
- Liquiphant S (high temperature)
FTL 70/71
Measuring cell for level limit detection in fluids
for fluid temperatures up to 280 °C
TI 354F/00/en
- Monorack II (for 1- and 2-channel devices)
for mounting a single Nivotester in the control room
TI 183F/00/en

Operating manual (KA)

1-channel:

- Nivotester
FTL 375 N-###1
Level limit switch with NAMUR input
KA 177F/00/a6

2-channel:

- Nivotester
FTL 375 N-###2
Level limit switch with NAMUR input
KA 178F/00/a6

3-channel:

- Nivotester
FTL 375 N-###3
Level limit switch with NAMUR input
KA 179F/00/a6

Certificates

ATEX:

- Nivotester
FTL 375 N
XA 148F/00/a3

DIBt:

- Liquiphant M, Liquiphant S
FTL 50/51, FTL 50 H/51 H, FTL 51 C, FTL 70/71
ZE 233F/00/de

Endress+Hauser GmbH+Co.

Instruments International
P.O. Box 2222
D-79574 Weil am Rhein
Germany

Tel. (07621) 975-02
Tx 773926
Fax (07621) 975 345
e-mail: info@ii.endress.com

Internet:
<http://www.endress.com>

Endress + Hauser
The Power of Know How

