

Retractable Assembly for pH/Redox Measurement *profit CPA 463S*

Process assembly for pneumatic operation with limit position signalling

Measurement of pH and redox values under process conditions requires assembly systems of superior quality and reliability. The Proffit process assemblies guarantee maximum life times, reduced maintenance and safe, reliable measurement even under high pressures and extreme temperatures.

The Proffit CPA 463S family of assemblies allow a pH or redox electrode to be sealed off, cleaned, calibrated or changed under process conditions. Plastic and metallic versions are available to cover the various requirements of industrial measuring applications. These assemblies are operated pneumatically.

Areas of application

- Chemical production
- Textile industry
- Effluent treatment
- Water treatment
- Electrode-critical processes
- Tank filling systems
- Power plants
- Automated pH measurement

Benefits at a glance

- Immersion depth of electrode 165 mm or 265 mm
- DN 50/PN 10 or 2" ANSI flange mounting
- Position feedback via pneumatic signal permits integration in automated process sequences
- Can be combined with fully automatic Airtrol calibration system and Autoclean automatic cleaning system.



Design

Construction of Probit CPA 463S assembly

- 1 Splash protection cap for measuring cable
- 2 Protective sleeve
- 3 Pneumatic cylinder
- 4 Rinse port G 1/4
- 5 Loose flange
- 6 Flanged sleeve
- 7 Electrode guide
- 8 Sealing piston
- 9 Pneumatic connections

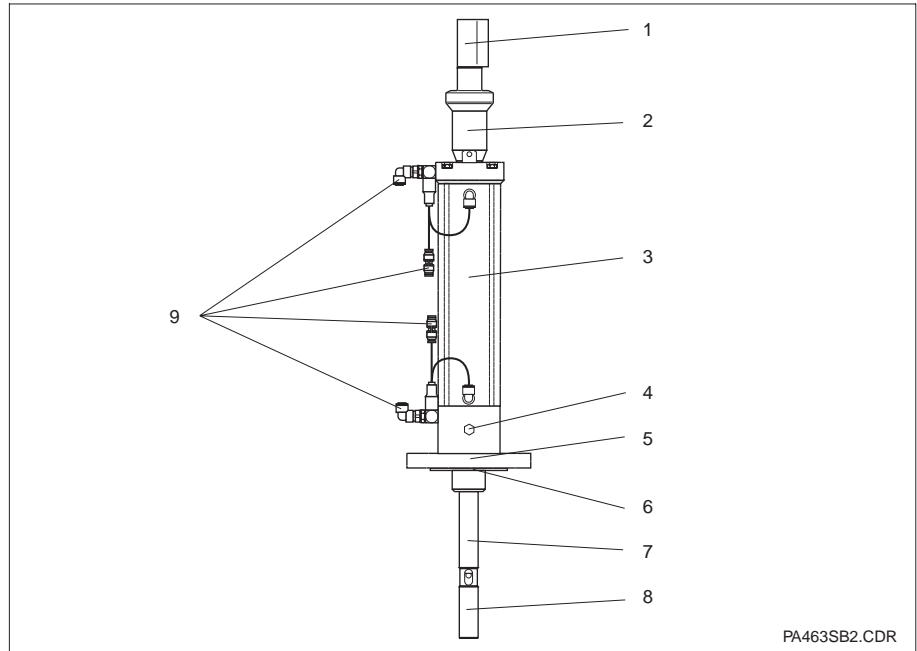

PA463SB2.CDR

The retractable assembly CPA 463S is installed via a loose flange. The electrode guide with the built-in pH/redox electrode can be actuated

- pneumatically with Probit CPA 463S-R or
- pneumatically for Airtrol CPC 200/210 with rinse port adapter (water valve block) and Probit CPA 463S-A.

The electrode guide is moved into the process space for measurement and retracted into the assembly for calibration, cleaning and electrode replacement.

When retracted, the assembly is sealed off from the process by means of a sealing piston. In this position, the electrode can be calibrated, cleaned, or replaced in a simple manner without interrupting the process.

Measuring system

Measuring system Probit CPA 463S with Airtrol CPC 200/210

- 1 Probit assembly CPA 463S
- 2 pH measuring cable
- 3 Multiple hose connection
- 4 Buffer 1
- 5 Buffer 2
- 6 Cleaning agent
- 7 Rinse port adapter

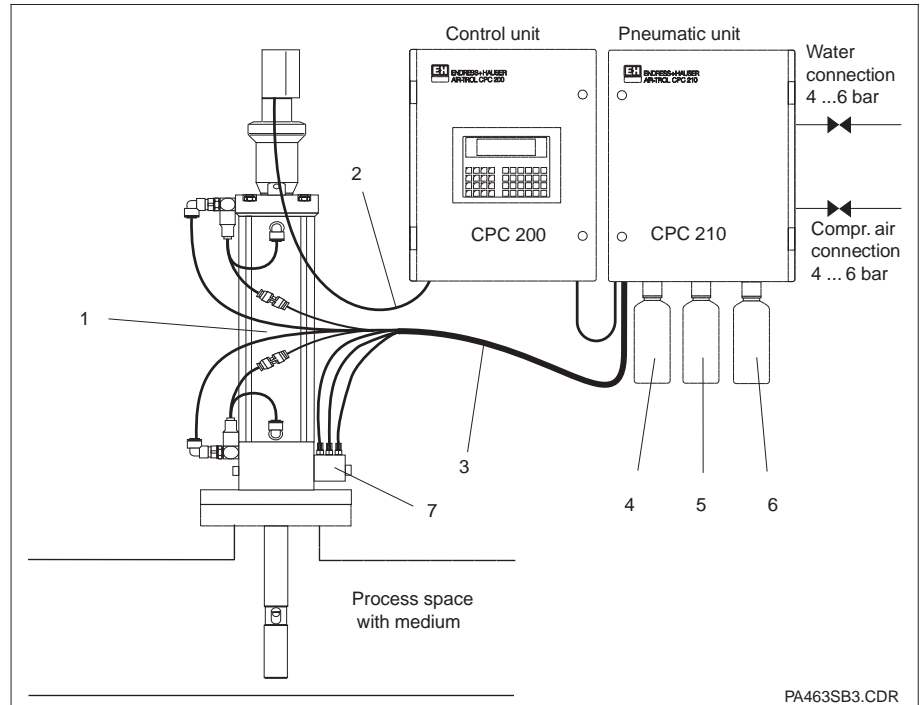

PA463SB3.CDR

A measuring system consists of:

- the Probit CPA 463S assembly,
- a pH/redox electrode, suitable for the assembly and the medium to be measured,
- a pH/redox measuring instrument, e.g. CPC 200/210,

- measuring cable CPK 1/CPK 7 (terminated), and
- connecting hoses for calibration buffer solutions and cleaning agent.

Pneumatic connections

The retractable assemblies CPA 463S-R and CPA 463S-A can be remote-controlled pneumatically:
 Two pneumatic signal outputs for the „measurement“ and „service“ limit positions are available for control or visual indication purposes .
 Control of the assembly has been simplified considerably by this.

A pneumatic switch is sufficient for operation. Installation is extremely simple since only 4 pneumatic control lines must be connected to the assembly. The assemblies can be combined with automatic cleaning and calibration systems Airtrol or Autoclean.

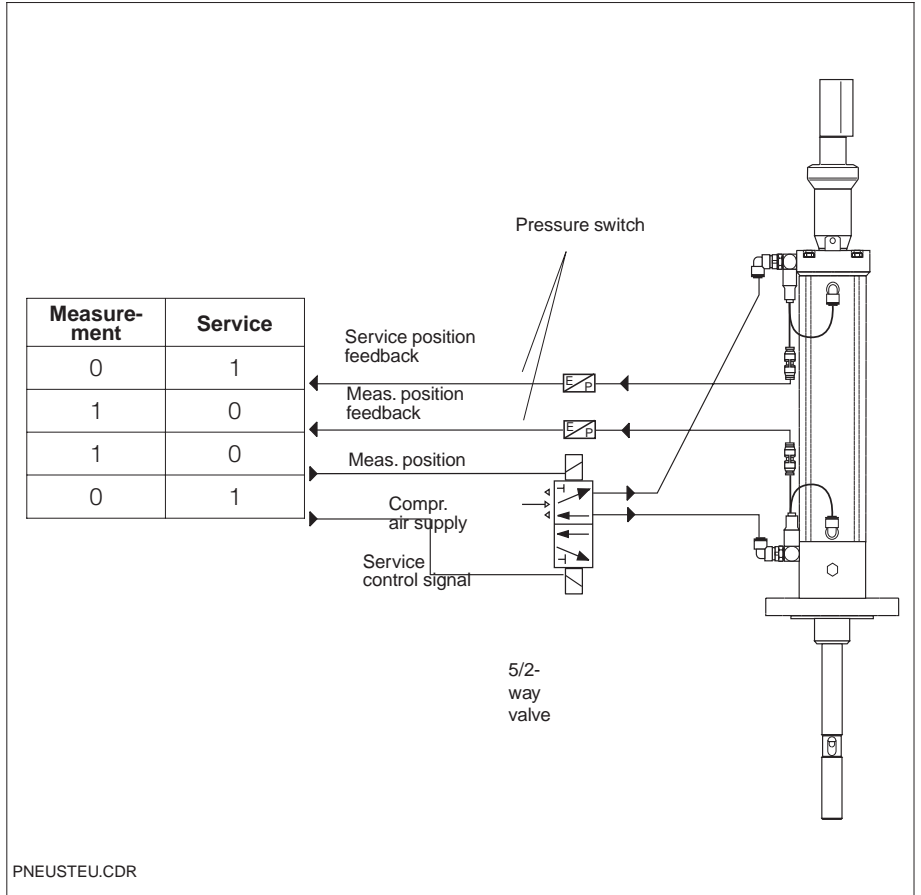

Pneumatic control unit
 Probit CPA 463S-A-R

Rinse port adapter for CPA 463S-A

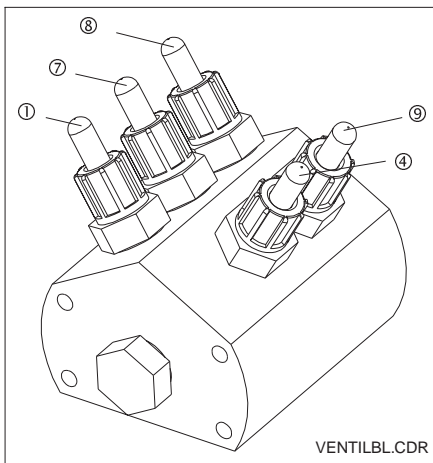

Rinse port adapter for
 Probit CPA 463S-A

- ① Water
- ② Rinse air
- ③ Cleaning solution
- ④ Buffer 2
- ⑤ Buffer 1

The following connections on the rinse port are available:

- water
- rinse air
- cleaning solution
- buffer 1
- buffer 2.

The connections are to be chosen as illustrated beside. Hose dimensions: OD 6/ID 4.

The rinse port adapter can be retrofitted for the CPA 463S-A version. (see accessories).

Installation and dimensions

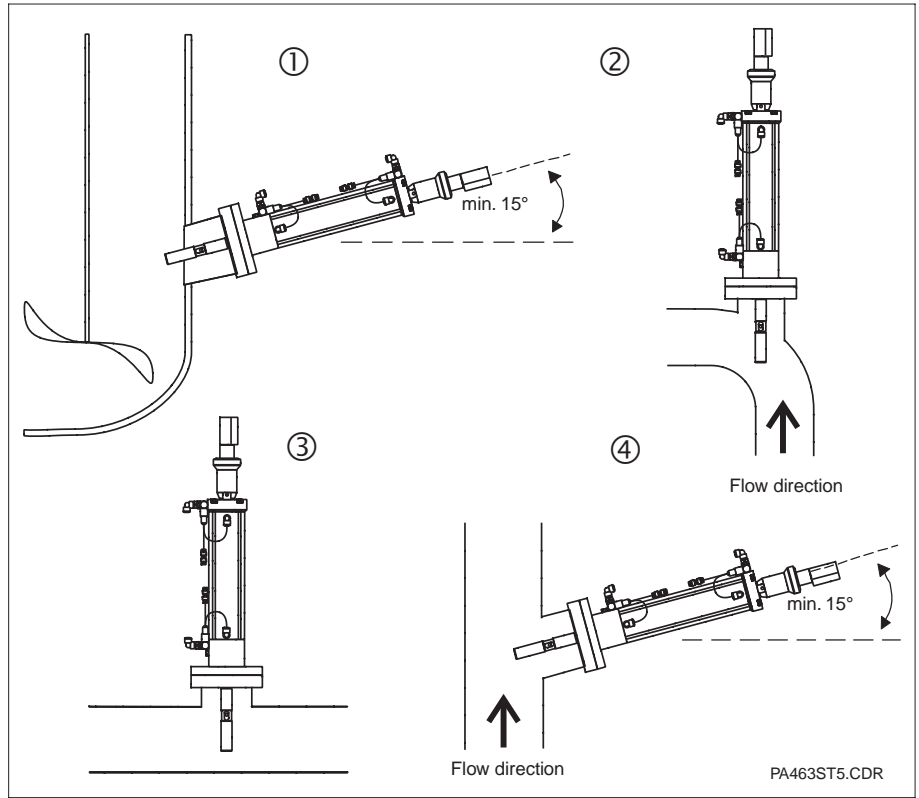

Examples for mounting
Probfit CPA 463 S

- ① Tank
- ② Bend
- ③ Horizontal pipes
- ④ Vertical pipes

PA463ST5.CDR

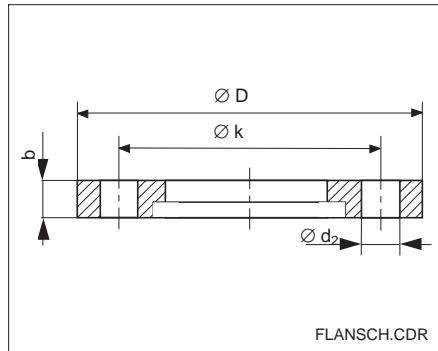

Loose flanges used on
Probfit assemblies
(included in scope of
delivery).

FLANSCH.CDR

	Flange	
	DN 50 / PN 10	ANSI 2", 150 lbs
ØD	165	152,4
Øk	125	120,6
Ød ₂	18	19
b	18	19
Bohrungen	8	4

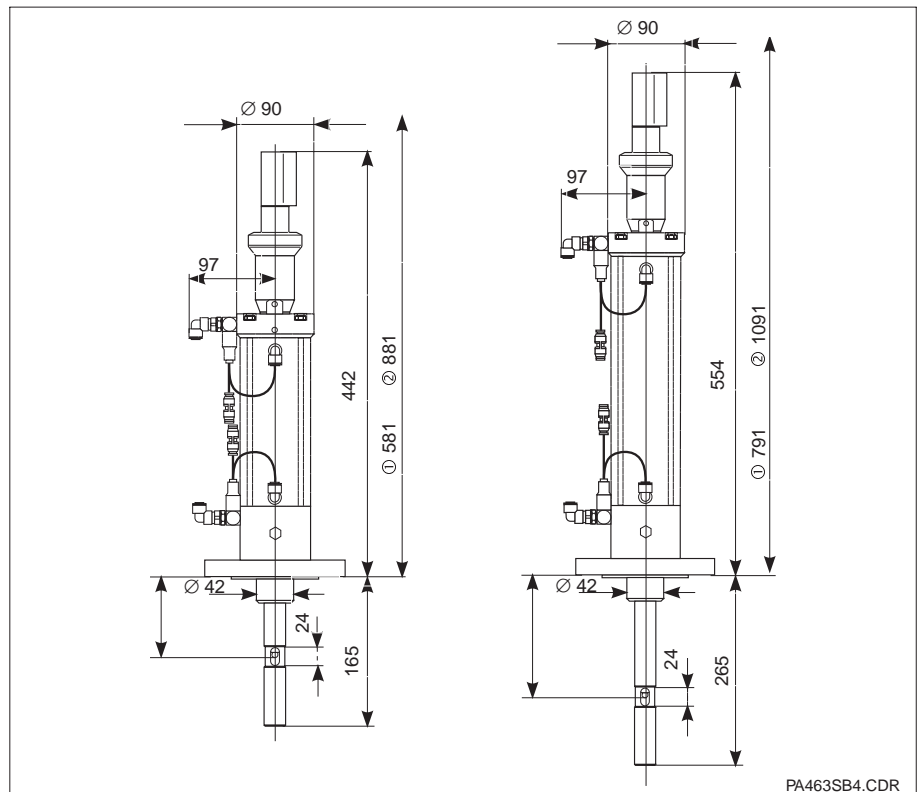

Dimensions of
Probfit CPA 463S

left
short version

right
long version

① Length in extended
state

② Required mounting
clearance

PA463SB4.CDR

Technical data

General data	Manufacturer	Endress+Hauser GmbH+Co.				
	Designation	Peobfit CPA 463S				
Installation	Complete immersion depth	165 mm, 265 mm *				
	Number of mounting positions in sensor holder	1 mounting position for pH combination electrode				
	Electrode length	360 mm				
	Electrode plug-in head	Pg 13,5				
Mounting	Flange version 1	4-hole DN 50 / PN 10 flange acc. to DIN 2501				
	Flange version 2	ANSI 2" flange				
Process connections	Rinse port adapter for CPA 463S-A	Inlet G 1/4 , outlet G 1/4				
	Hose connections	5 hose connections OD6 / ID4				
	Pneumatic control conduits	4 hose connections OD6 / ID 4				
Weight	PVC version	3,5 kg / 5 kg				
	PVDF / PEEK version	3,5 kg / 5 kg				
	stainless steel 1.4571 / HC4 version	5,5 kg / 8 kg				
Materials in contact with medium	CPA 463S-R / -A version:	PVC	PVDF	1.4571	PEEK	HC4
	Pneumatic cylinder	PVC	PVC	PVC-C	PVC-C	PVC-C
	Housing	PVC	PVDF	PVDF	PEEK	PEEK
	Electrode guide	PVC	PEEK	1.4571	PEEK	HC4
	Flanged sleeve	PVC	PVDF	1.4571	PEEK	HC4
	Flange	PVC	UP-GF	1.4571	UP-GF	1.4571
	Seals	EPDM, Viton, Chemraz				
Operating data	CPA 463S-R / -A	Pressure / temperature:				
	PVC	6 bar / 20 °C; 0 bar / 60 °C				
	PVDF	6 bar / 20 °C; 1 bar / 100 °C				
	Stainless steel 1.4571, PEEK, HC4	6 bar / 100 °C				
	Compressed air	3 ... 6 bar				
	Compressed air quality	filtered (5 µm), water and oil free				

* Caution: Ceraliquid electrodes (CPS 41 / CPS 42) cannot be used with an immersion depth of 265 mm.

Subject to modifications

Accessories

Endress+Hauser offers the following special accessories for the retractable assemblies Probit CPA 463S:

- Rinse port adapter
Order no. 50092132
- Retraction security lock
Order no. 50051999
- Protection cap for liquid filled electrodes CPS 41
Order no. 50080932
- pH/redox combination electrodes acc. to the following tables:

pH combination electrodes, length 360 mm:

Electrode type/ Order no.	Temperature	pH range
CPS 11-1AA5GSA	-15 ... 80 °C	1 ... 12
CPS 11-2AA5TSA	-15 ... 80 °C	1 ... 12
CPS 11-1BA5GSA	10 ... 130 °C	0 ... 14
CPS 11-2BA5TSA	10 ... 130 °C	0 ... 14
CPS 41-2BB5TSS	10 ... 130 °C	0 ... 14

Redox combination electrode, length 360 mm:

Electrode type/ Order no.	Temperature	pH range
CPS 12-0PA5GSA	-15 ... 130 °C	0 ... 14

- Buffer solution CPY 2
- Measuring cable CPK 1 or CPK 7

Endress+Hauser offers the following control systems for automatic cleaning and calibration of the retractable assemblies:

- Autoclean CPC 20
Automatic cleaning control unit
Technical Information TI 161C/07/en
Order no. 50089158
- Airtrol CPC 200 / 210
Automatic cleaning and calibration unit
Technical Information TI 095C/07/en
Order no. 50061485
- Airtrol 500
Hand-operated unit
Technical Information TI 038C/07/en
Order no. 50057223

How to order

Retractable assembly Probit CPA 463S

Version

- A with rinse / calibrator connection for Airtrol
- R with rinse connection G 1/4

Immersion depth / material

- 01 165 mm / PVC
- 02 165 mm / PVDF/PEEK
- 12 265 mm / PVDF/PEEK
- 03 165 mm / 1.4571
- 13 265 mm / 1.4571
- 04 165 mm / Hastelloy C4
- 14 265 mm / Hastelloy C4
- 05 165 mm / PEEK
- 15 265 mm / PEEK

O-ring-material

- 1 EPDM
- 2 Viton
- 3 Chemraz

Mounting type

- 1 DN50 / PN10 flange mounting
- 2 ANSI 2" flange mounting.

CPA 436S-

complete order code

**Endress+Hauser GmbH+Co.
- Instruments International -**

P.O. Box 2222
D-79574 Weil am Rhein
Tel. (0 76 21) 9 75 - 02
Fax (0 76 21) 9 75 3 45

Endress + Hauser
Nothing beats know-how

