

Thermocouple temperature sensor omnigrad S TSC 262

***Thermometer with EEx d certification
Lamination nipple and/or 3 elements coupling
Matchable with pipe thermowells***



The Omnigrad S TSC 262 is an industrial thermometer with thermocouple (type J, K), developed for the use in the chemical, petrochemical and energy industries but suitable also for other generic applications.

The TSC 262 is supplied with EEx d certification, in compliance with European standards EN 50014 and EN 50018, and is therefore suitable also for industrial areas with potentially explosive environments.

The TSC 262, which is available in several standard versions and different configurations, can also be configured with specific dimensions and characteristics depending on process requirements. Installation in EEx d systems requires separately ordered pipe thermowell.

Features and benefits

- Transmitters with 2-wire technology (PCP 4...20 mA, HART®, PROFIBUS-PA®)
- Customisable immersion length
- Head/thermowell connection fitting in SS 304 (nipple + 3 elements coupling)
- Explosion-proof enclosure with EEx d certification and lamination coupling on the insert
- Mineral oxide replaceable insert (MgO)
- Thermocouple sensing element (type J or K) with class 1 or 2 accuracy (DIN EN 60584)

Endress + Hauser

The Power of Know How



Areas of application

The TSC 262 can also be used in generic industrial applications but is particularly suitable for EEx d certified applications like:

- chemical industry
- petrochemical industry
- energy industry
- gas processing industry.

Function and system design

Measuring principle

The thermocouple thermometer's sensing element consists of two metal wires that are homogeneous but different one from the other and insulated along their entire length. The two wires are welded together at one end, known as the "measurement or hot junction". The other end, where the wires are free, is known as the "cold or reference junction" and is connected to a electromotive force measurement where the force is generated by the different thermoelectric power of each of the thermocouple's wires if there is a temperature difference between the hot joint (T_1) and the cold joint (Seebeck effect). The cold junction has to be "compensated" with reference to the temperature of 0°C (T_0).

The function that links the electromotive force to the temperatures T_1 and T_0 is a curve whose characteristics depend on the materials used in the construction of the thermocouple. Some thermocouples curves, and particularly those most reliable for the purposes of industrial readings, are those compliant with standards DIN EN 60584 and ANSI MC96.1.

Equipment architecture

The TST 262 thermocouple thermometer comprises:

- an EEx d certified aluminium housing
- an insert with thermocouple (type J or K), insulated with mineral oxide (MgO), with oversheath and terminals on a ceramic support
- lamination nipple and 3 elements coupling.

Dimensions are determined as follows (fig. 1):

- N = length of the head/thermowell connection fitting
- ML = insert immersion length.

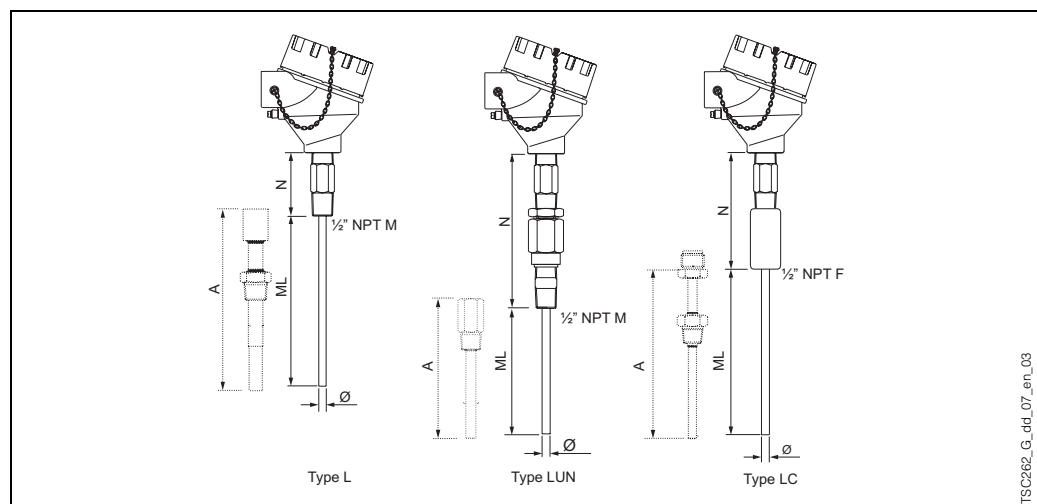

Fig. 1: General information on sizes

Material

Housing: treated and painted aluminium alloy.

Measuring insert: external sheath in SS 316/1.4401 or Inconel® 600/2.4816.

Head/thermowell connection: SS 304/1.4301 or A105/1.0460.

Weight

From 1 to 1.5 Kg for standard options.

Electronics

The required type of output signal can be obtained by choosing the correct head-mounted transmitter.

Endress+Hauser supplies "state-of-the-art" transmitters (the iTEMP® series) built in 2-wire technology and with 4...20 mA output signal, HART® or PROFIBUS-PA®. All transmitters can be easily programmed using a personal computer and the ReadWin® 2000 public domain software (for transmitters 4...20 mA and HART®) or the Commuwin II software (for PROFIBUS-PA® transmitters). HART® transmitters can also be programmed with the hand-held operating module DXR 275 (Universal HART® Communicator).

For more detailed information on the transmitters, see the related documentation (codes TI at the end of this document).

If no head transmitter is used, it is also possible to connect the thermocouple to a remote transmitter DIN-rail.

Performance

Operating conditions

Ambient temperature

- Metal head with terminal block and without transmitter -40÷130°C
- Metal head without terminal block and with transmitter -40÷85°C

Shock and vibration resistance

According to DIN EN 60751 3 g peak / 10÷500 Hz

Accuracy

The tolerances set by the standard DIN EN 60584 are the following:

Type	Standard tolerance (DIN EN 60584)		Special tolerance (DIN EN 60584)	
	Class	Max. deviation	Class	Max. deviation
J (Fe-CuNi)	2	+/-2.5°C (-40...333°C) +/-0.0075 t (333...750°C)	1	+/-1.5°C (-40...375°C) +/-0.004 t (375...750°C)
K (NiCr-Ni)	2	+/-2.5°C (-40...333°C) +/-0.0075 t (333...1200°C)	1	+/-1.5°C (-40...375°C) +/-0.004 t (375...1000°C)

Note! (|t|=absolute temperature value in °C)

Transmitter maximum error

See the corresponding documentation (codes are shown at the end of this document).

Measurement range

- Type J sensor -40...750°C
- Type K sensor -40...1100°C

Response time

Tests in water at 0.4 m/s (according to DIN EN 60751; temperature variation from 23 to 33°C), only on the TC thermometer insert:

- t_{50} 2.5 s
- t_{90} 7 s

Insulation

Insulation resistance between terminals and probe sheath > 1 GΩ at 25°C
(in accordance with DIN EN 60584, test voltage 500 Vdc) > 5 MΩ at 500°C

Installation

The Omnigrad S TSC 262 can be installed on pipes or tanks by means of bar stock thermowells with connections usually threaded or flanged.

The immersion length must take into account all the parameters of the thermometer and thermowell in the process to measure. If the immersion is too low, an error may be generated in the temperature recorded due to the lower temperature of the process fluid near to the walls and heat transfer, which takes place through the sensor stem. The incidence of such an error can be not negligible if there is a big difference between the process temperature and the ambient temperature. To prevent measuring errors of this kind, it is advisable to use thermowells with a small diameter and an immersion length (L) of at least 100÷150 mm.

In small section ducts the tubing's axis must be reached and preferably slightly exceeded by the tip of the probe (see fig. 2A-2C). Insulation of the outer part of the sensor reduces the effect produced by a low immersion. Alternatively, it is also possible to adopt a tilted installation (see fig. 2B-2D).

In processes involving gases at very high temperature (>500÷600°C), where radiation effects are important, the immersion length may be a secondary problem.

For corrosion problems, it is important to carefully select the material of the thermowell; Endress+Hauser supplies a wide range of thermometric wells suitable to all types of applications. Even the nipples and 3 elements coupling supplied with the connection fitting of the instrument are able to withstand a wide range of aggressive substances. For further information on specific applications, contact the E+H Customer Service Department.

Disassembled components of the sensors must be reassembled with the recommended clamping torques in order to ensure the appropriate IP protection class within the sensor-housing coupling.

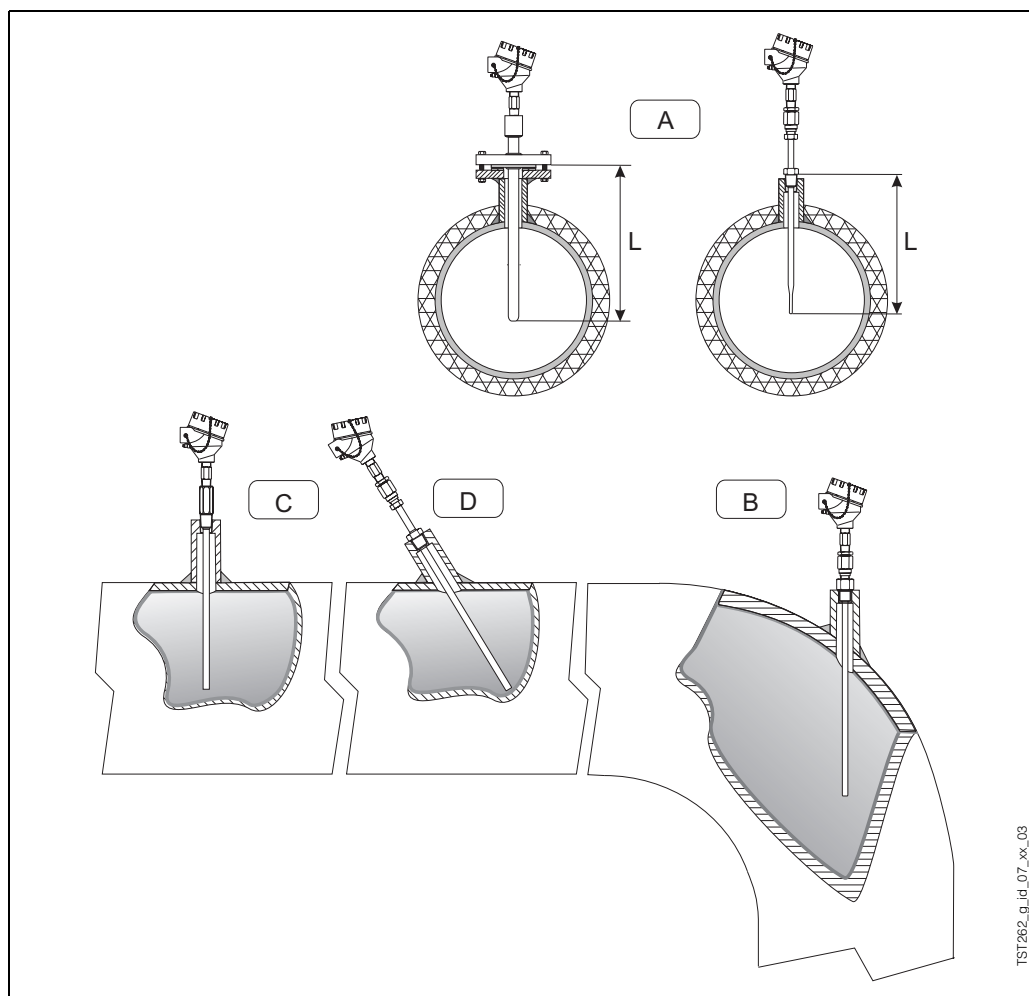

Fig. 2: Installation on pipes and tanks by means of flanged or threaded process connections

System components

Housing

The protection housing, commonly referred to as "connection head" is used to contain and protect the terminal block or the transmitter and to join the electric connections to the mechanical component.

The head used for the TSC 262 is compliant with DIN 43729 (form B) and EN 50014/50018 standards (EEx certification for explosion-proof instruments).

The matching of the head with the extension below the head and the cover (threaded) ensures an IP66 class of protection.

The head also has a chain to connect the body to the cover, which facilitates the use of the instrument during the maintenance on systems.

The single or double electrical cable input has M20x1.5, 1/2" NPT or 3/4" NPT threading.

Head transmitter

Available head transmitters include (see also section "Electronics"):

- TMT 181
- TMT 182
- TMT 184

PCP 4...20 mA
Smart HART®
PROFIBUS-PA®.

The TMT 181 is a PC programmable transmitter.

The TMT 182 output consists of 4...20 mA and HART® superimposed signals.

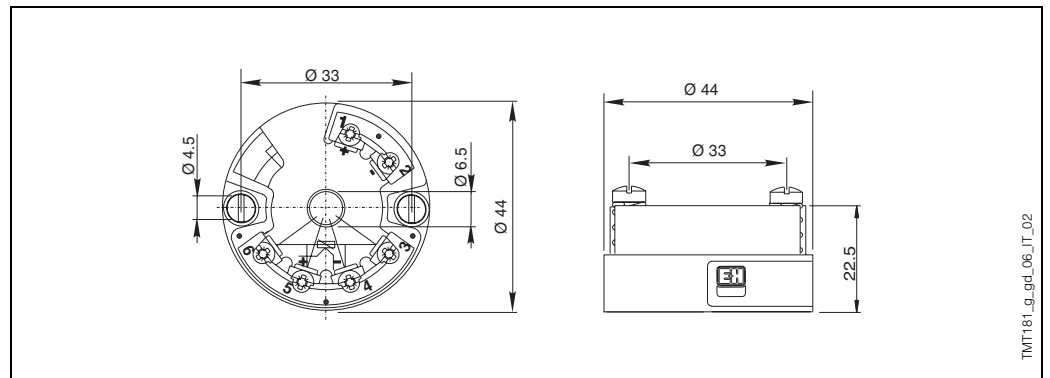

Fig. 3: TMT 181 - 182

In the TMT 184, with a PROFIBUS-PA® output signal, the communication address can be set via software or by means of a mechanical dip-switch (the configuration must be specified by the customer in order phase).

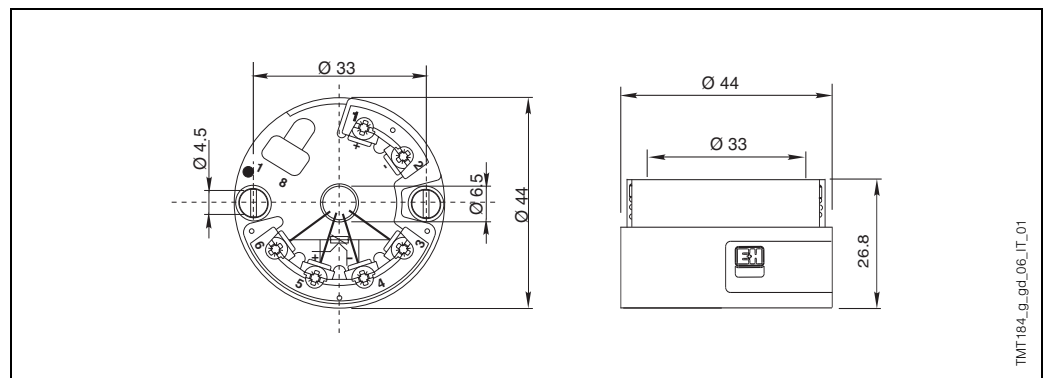

Fig. 4: TMT 184

Extension neck

The extension neck is the part between the thermowell and the transmitter housing. To prevent the process temperature from overheating the area of the transmitter, a special extension "neck" is inserted between the sensor, exposed to high temperature processes, and the transmitter. This enables to limit the operating temperature of the transmitter.

It normally consists of hydraulic connections (nipples and/or joints) that are suitable to allow the adjustment of the sensor to the thermowell.

The standard lengths (N) and the versions of the extension neck can be selected among the following options:

- 52 mm (only 1/2" NPT threaded nipple, type L)
- 148 mm (nipple+3 elements coupling+nipple, type LUN)
- 96 mm (nipple+coupling, type LC).

Threaded thermowell connections					
Type	Thread	Length N (mm)	C (mm)	Detail	Type of neck
Male	1/2" NPT	52	8		
		148			
Female		96			



Attention! * This neck is available only for 1/2" NPT threads

"LUN" connections enable to orient the transmitter housing.

As illustrated by the chart in figure 5, the length of the sensor + thermowell extension may influence the temperature in the head. It is necessary that this temperature is kept within the limit values defined in the paragraph "Operating conditions".

In addition to the standard versions listed above, it is also possible to order the extension neck by specifying the desired length (see "Sales structure" chart).

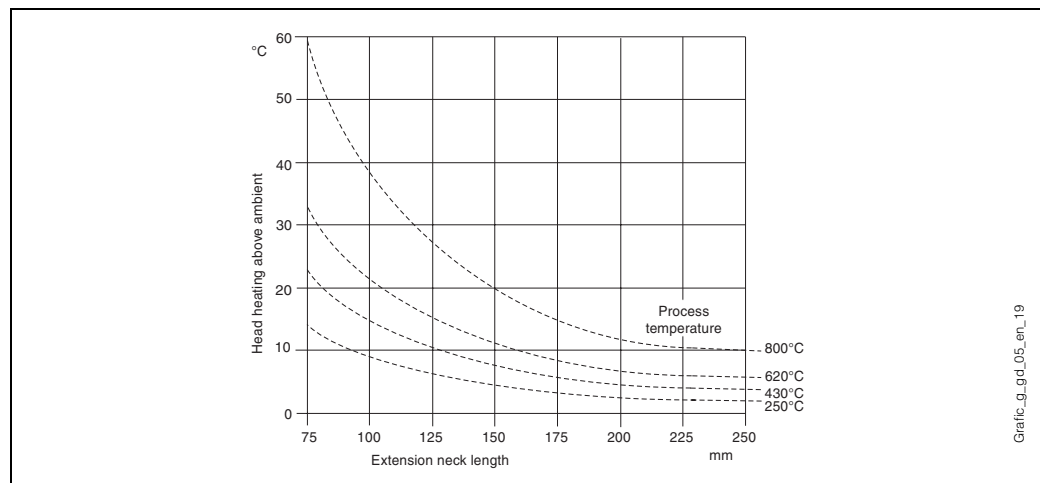

Fig. 5: Heating of the head caused by the process temperature

Probe

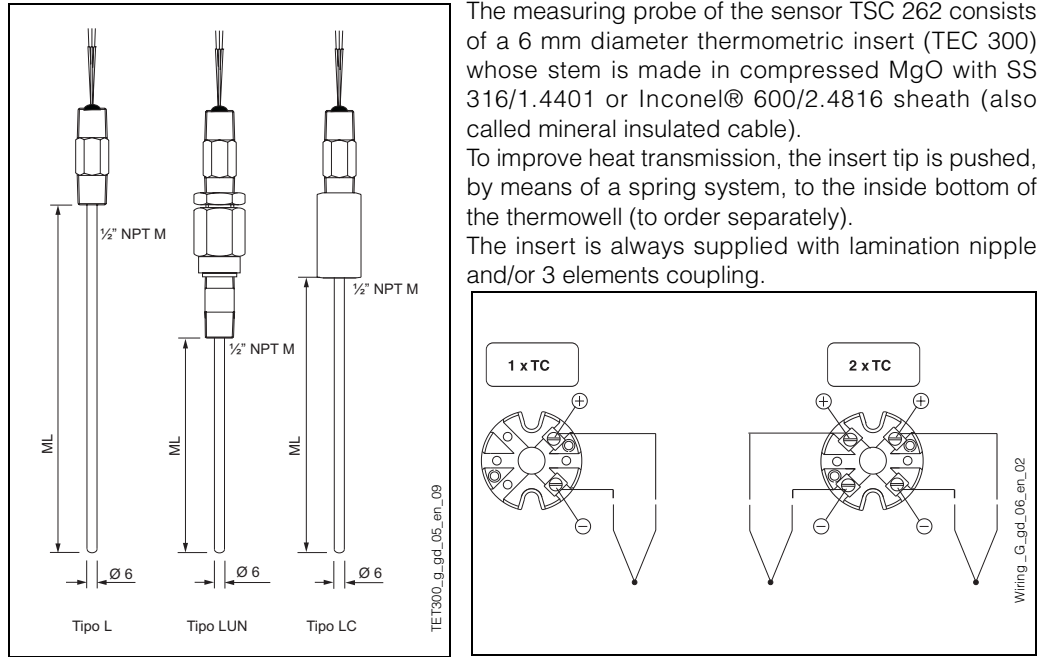

Fig. 6: Probe, dimensions and internal wiring

The length of the sensor can be chosen within a range of 50...4000 mm. Sensors with a length above 4000 mm can also be ordered and supplied after a technical analysis of the application and thermowell in which the sensor will be used. The immersion length (ML) must be calculated according to the total length of the thermowell (A) and the type of thermowell used. Also if spare part inserts are necessary, consult the following table (applicable to standard thickness well bottoms):

Type of thermowell	ML	Type of thermowell	ML
TW 10	ML = A - 8	TA 540	ML = A - 10
TW 11	ML = A - 8	TA 541	ML = A - 10
TW 12	ML = A - 8		
TW 13	ML = A - 8		
TA 535	ML = A - 8		

In the case of thermowells with non-standard bottoms, use the following formula:
 $ML = A - D - 5$
 where D = thickness of bottom.

Certificates & Approvals

Ex approval

Certificate CESI 03 ATEX 114, 2 G IIC EEx d T5/T6.

PED approval

The Pressure Equipment Directive (97/23/CE) is respected. As paragraph 2.1 of Article 1 is not applicable to this kind of instrument, the marking **CE** is not mandatory for TSC 262 models used for generic applications.

Further details

Maintenance

The TSC 262 does not require specific maintenance.

Delivery time

For small orders (5 to 10 units) and standard options, the delivery time is 25 working days.

Ordering information

Sales structure

TSC 262		Neck length N, material and type of connection			
1	52 mm	SS 304	Type L	1/2" NPT-M	
2	148 mm	A105	Type LUN	1/2" NPT-M	
3	148 mm	SS 304	Type LUN	1/2" NPT-M	
0	96 mm	SS 304	Type LC	1/2" NPT-F	
9	Extension length to be specified				
		Insert length ML (50 to 4000 mm)			
XX	mm	insert length to be specified			
YY	mm	special insert length			
		Insert type, diameter and material			
AF	1xTC IEC584 type K, D = 6 mm material Inconel® 600				
BE	1xTC IEC584 type J, D = 6 mm material SS 316				
YY	Special version				
		MgO cable, purity and tolerance class			
1	Standard purity, tolerance class 2				
2	Standard purity, tolerance class 1				
		Type of electrical connection			
2	Flying wires				
3	2-terminal ceramic terminal block				
		Hot junction type			
G	Grounded hot junction				
J	Insulated hot junction				
		Head cable entry			
A	Head cable entry: single, 1/2" NPT				
C	Head cable entry: single, 1/2" NPT				
B	Head cable entry: single, 3/4" NPT				
D	Head cable entry: double, 3/4" NPT				
E	Head cable entry: single, M20x1.5				
F	Head cable entry: double, M20x1.5				
		Built-in head transmitter			
0	Without built-in head transmitter				
P	2-wire transmitter PCP TMT 181-A, galvanically insulated, adjustable range from ...to...°C				
R	2-wire transmitter HART® TMT182-A, galvanically insulated, adjustable range from ...to...°C				
S	2-wire transmitter PROFIBUS-PA®, TMT184-A				
1	Built-in head transmitter THT1, to be ordered separately				
TSC262-					Complete order code

Supplementary documentation

- | | |
|---|---------------|
| <input type="checkbox"/> General technical information on TSC thermometers | TI 090T/02/en |
| <input type="checkbox"/> General technical information on TA thermowells | TI 138T/02/en |
| <input type="checkbox"/> Temperature transmitter- iTEMP® PCP TMT 181 | TI 070R/09/en |
| <input type="checkbox"/> Temperature transmitter - iTEMP® HART® TMT 182 | TI 078R/09/en |
| <input type="checkbox"/> Temperature transmitter- iTEMP® PA TMT 184 | TI 079R/09/en |
| <input type="checkbox"/> Thermocouple insert for EEx-d. Omniset TEC 300 | TI 226T/02/en |
| <input type="checkbox"/> Safety instructions for use in hazardous areas | XA 007T/02/z1 |
| <input type="checkbox"/> E+H Laboratory Calibration certifications for industrial thermometers.
<i>RTD and thermocouples</i> | TI 236T/02/en |

Subject to modification

Endress+Hauser
GmbH+Co. KG
Instruments International
P.O. Box 2222
Colmarer Str. 6
D-79574 Weil am Rhein
Germany

Tel. +49 7621 97502
Fax. +49 7621 975345
<http://www.endress.com>
info@ii.endress.com

Endress + Hauser
The Power of Know How

