

# Level Probes *multicap DC 11/16/21/26 AN* *multicap DC 11/16/21/26 AS*

**Fully and partially insulated rod and rope probes  
for capacitive level measurement  
and limit detection  
(North American certificates)**

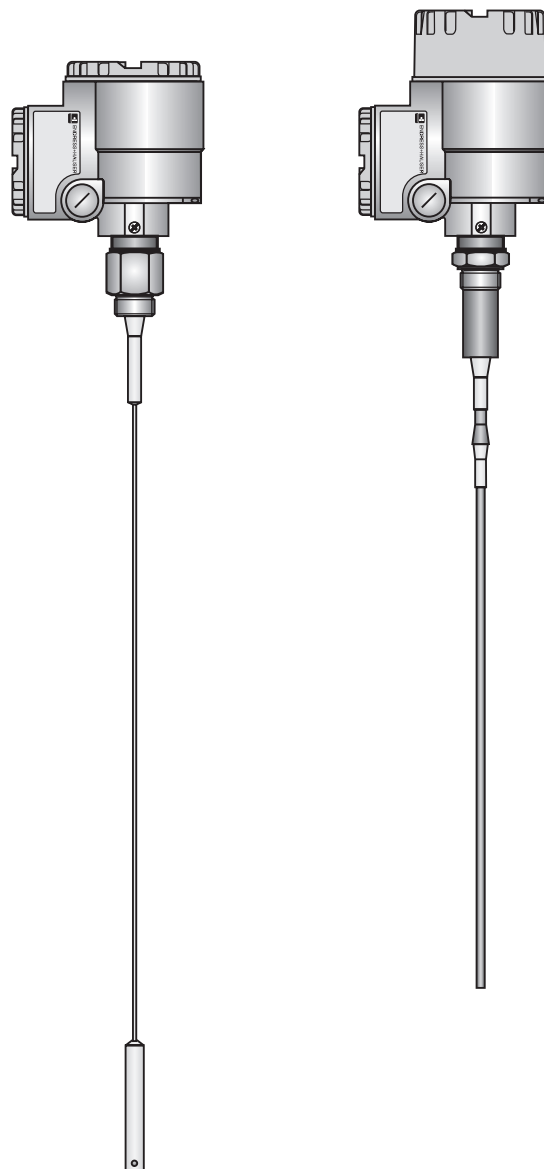

## Application

Multicap probes are designed for continuous level measurement and limit detection, primarily in liquids. The DC 11 and DC 16 rod probes are also suitable for use in light bulk solids.

The probe rod or probe rope and insulation are made of corrosion-resistant materials able to withstand extremely aggressive products. The tried-and-tested rugged construction is gas-tight for pressure from vacuum to 1450 psi. Seal and insulation materials enable probes to be used at operating temperatures in the vessel of -110°F to +390°F.

## Features and Benefits

Certificates from many North American approval authorities  
= the probes have universal use

Versions for a wide range of applications  
= ideally adapted to your application at a cost effective price

Screened against condensation in the nozzle  
= reliable function even with condensation

Active build-up compensation for limit detection  
= steady and accurate switchpoint even with heavy contamination on the probe, no cleaning or recalibration

Endress + Hauser

The Power of Know How



# Measuring System

Left: Limit detection with separate Nivotester switching unit

Right: Level measurement with separate Silometer transmitter

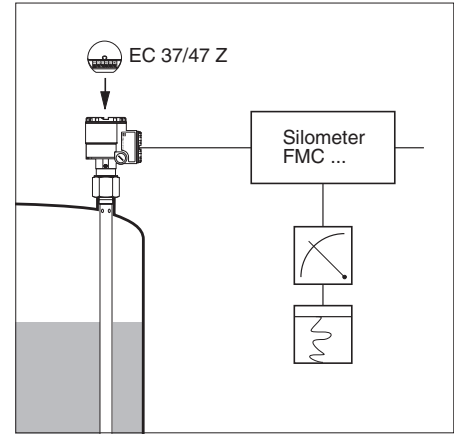
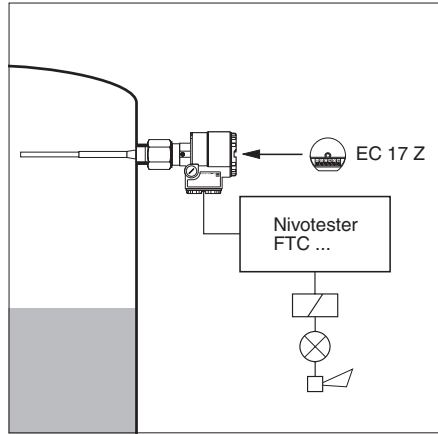

Left: Compact level switch with relay or transistor output

Right: Compact level measurement system with standard 4...20 mA current output and superimposed communications signal. FEC 12: "Smart electronic insert" which allows remote calibration over two-wire cabling (HART protocol) FEC 14: Communication and commissioning with PROFIBUS PA

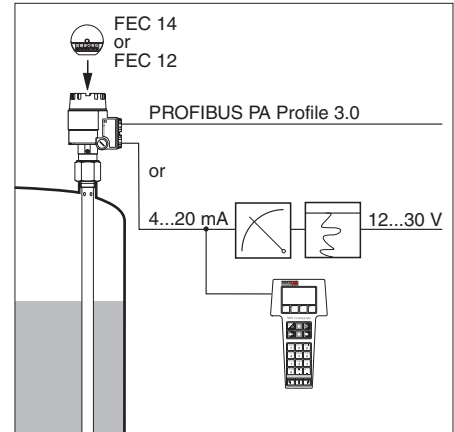
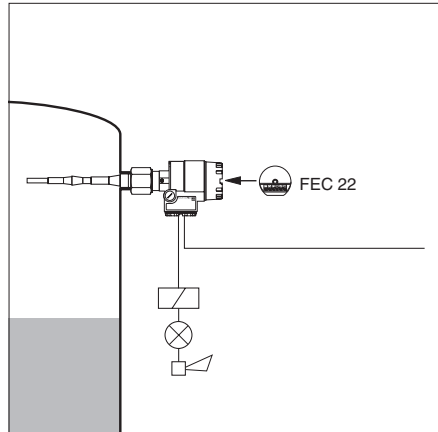

# Probe Selection

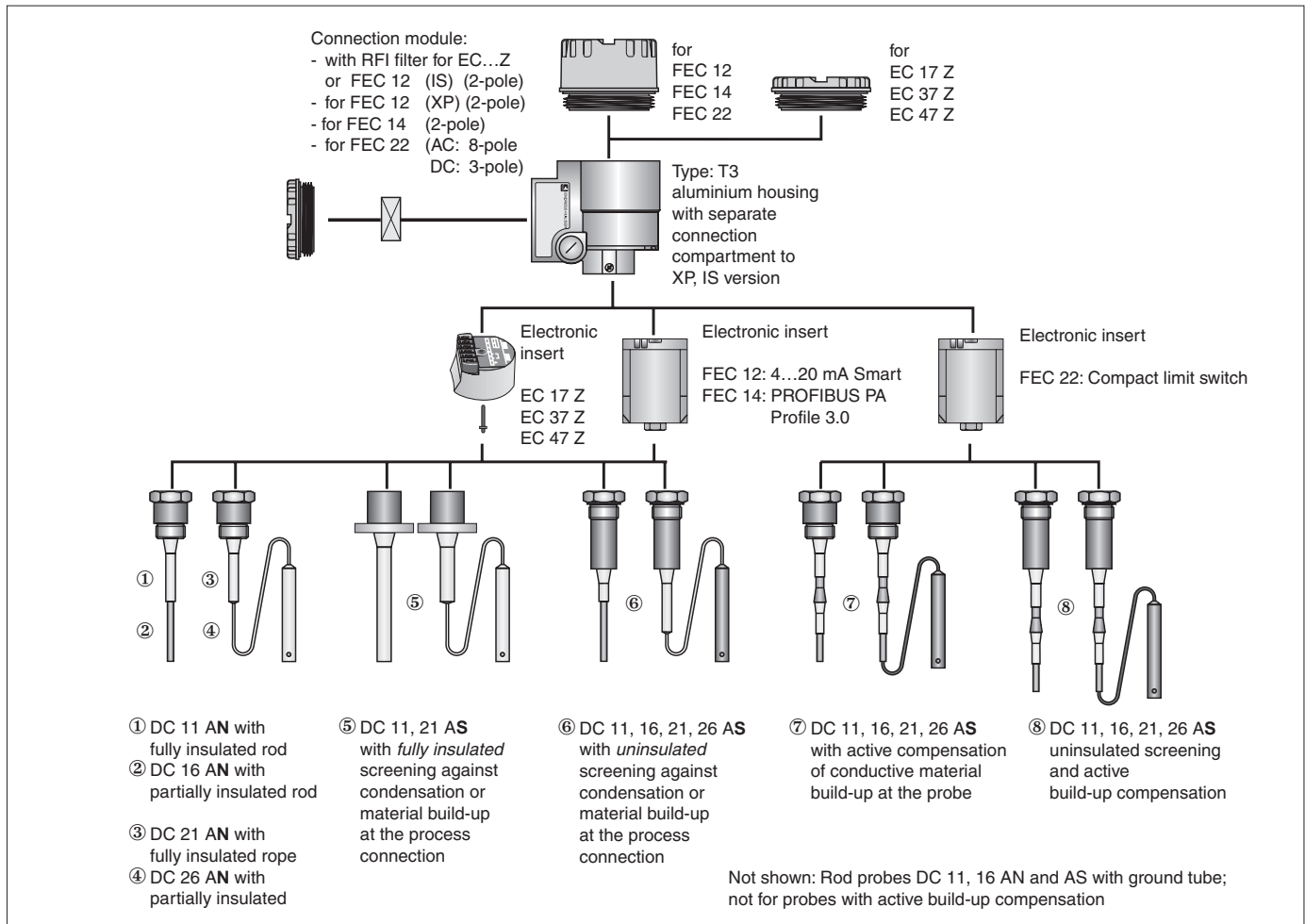

# Dimensions

## DC 11/16/21/26 AN

All dimensions in inches.  
 Threaded process connections: 1½ - 11½ NPT  
 see Page 6 for other process connections and housing dimensions

L1 = Length of active probe rod or probe rope

L2 = Length of partial insulation  
 minimum: 3 in  
 maximum: length L1 minus 2 in

Left: DC 11 AN, fully insulated rod probe

Right: DC 16 AN, partially insulated rod probe

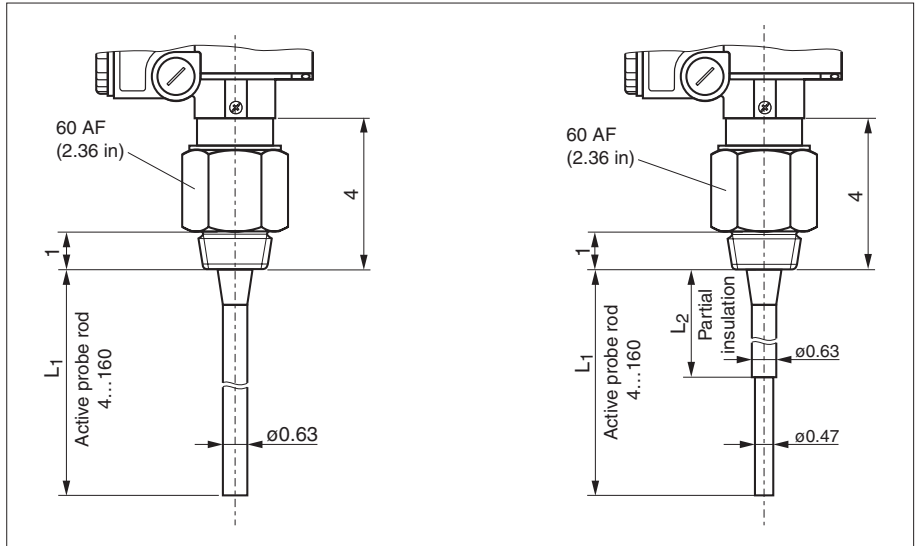

Left: DC 11 AN, fully insulated rod probe with ground tube

Right: DC 16 AN, partially insulated rod probe with ground tube

Spacers every 40 in, of PFA

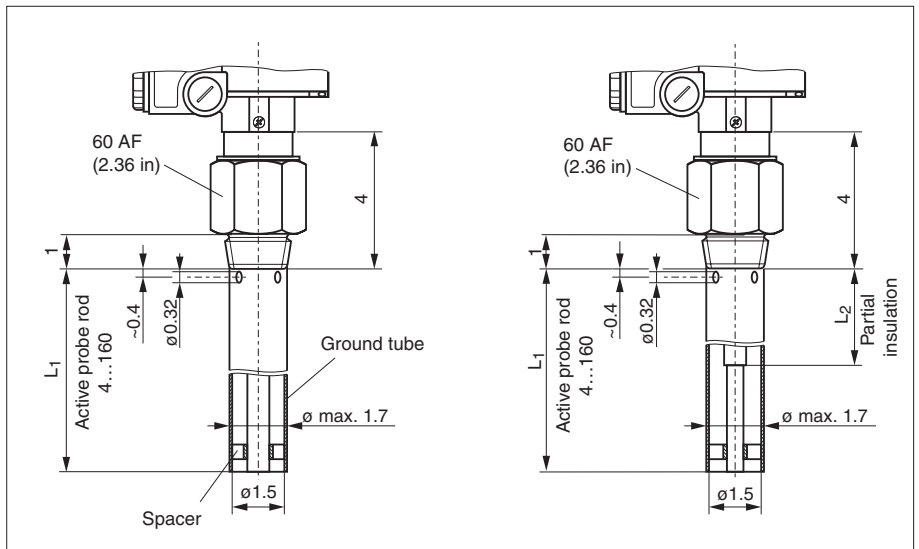

Left: DC 21 AN, fully insulated rope probe

Right: DC 26 AN, partially insulated rope probe

Tensioning weight always with anchor hole

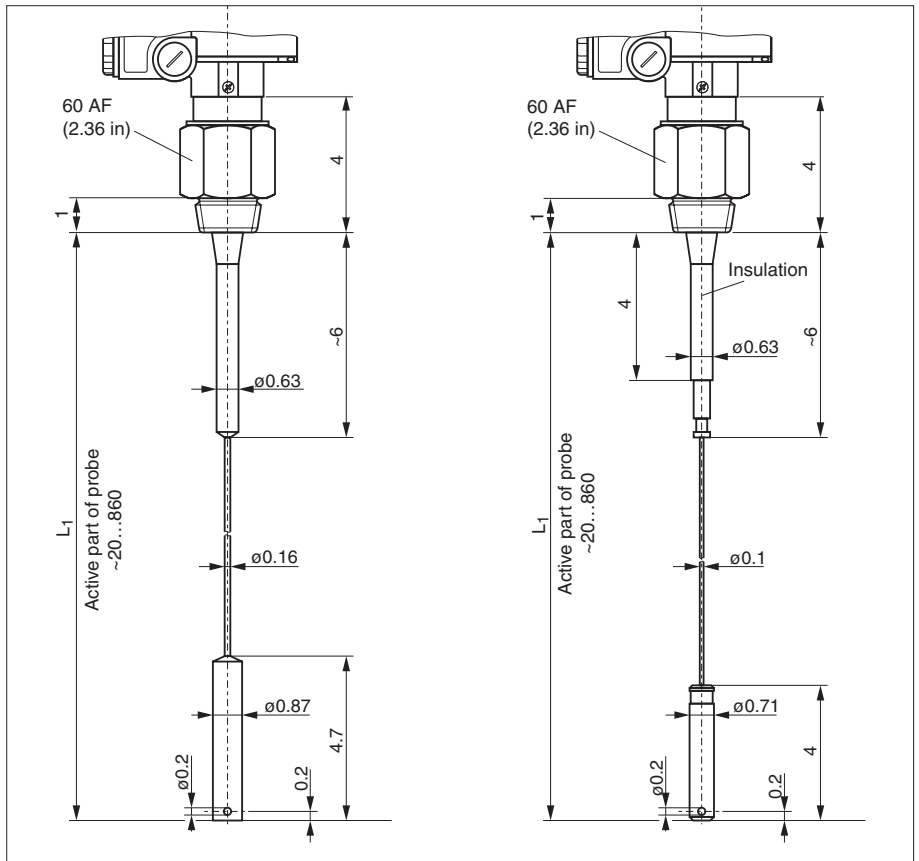

# Dimensions

## DC 11/16/21/26 AS

All dimensions in inches.  
Threaded process connections 1½ - 11½ NPT

**Probe with screening L3 against condensation and material build-up at the process connection (inactive section)**

see Page 6 for other process connections

L1 = Length of active probe rod or probe rope  
L2 = Length of partial insulation  
minimum: 3 in  
maximum: length L1 minus 2 in

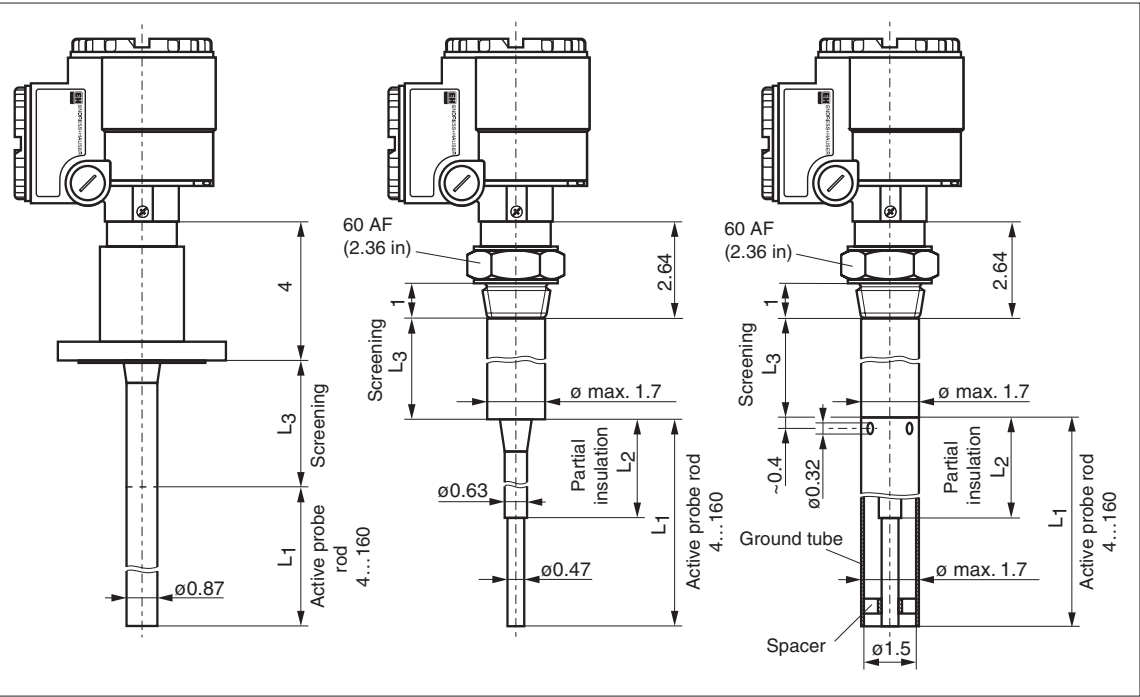

Above left: DC 11 AS, fully insulated rod probe with **fully** insulated screening and plastic coated flange

Above, centre and right: rod probes with uninsulated screening, with partially insulated rod with full insulation also available:

DC 11 AS, fully insulated  
DC 16 AS, partially insulated

With ground tube DC 11 AS, fully insulated  
DC 16 AS, partially insulated

Left: DC 21 AS, fully insulated rope probe with **fully** insulated screening and plastic coated flange

Right: DC 26 AS, partially insulated rope probe with uninsulated screening, uninsulated rope and uninsulated tensioning weight (as shown)

With fully insulated active section this probe is designated DC 21 AS

**L3**  
The screening (protection against condensation) is available in three standard lengths:  
L3 = 6 in  
L3 = 9 in  
L3 = 20 in

Other lengths on request  
L3 min. 4 in  
L3 max. 160 in (uninsulated screening)  
L3 max. 80 in (fully insulated screening)

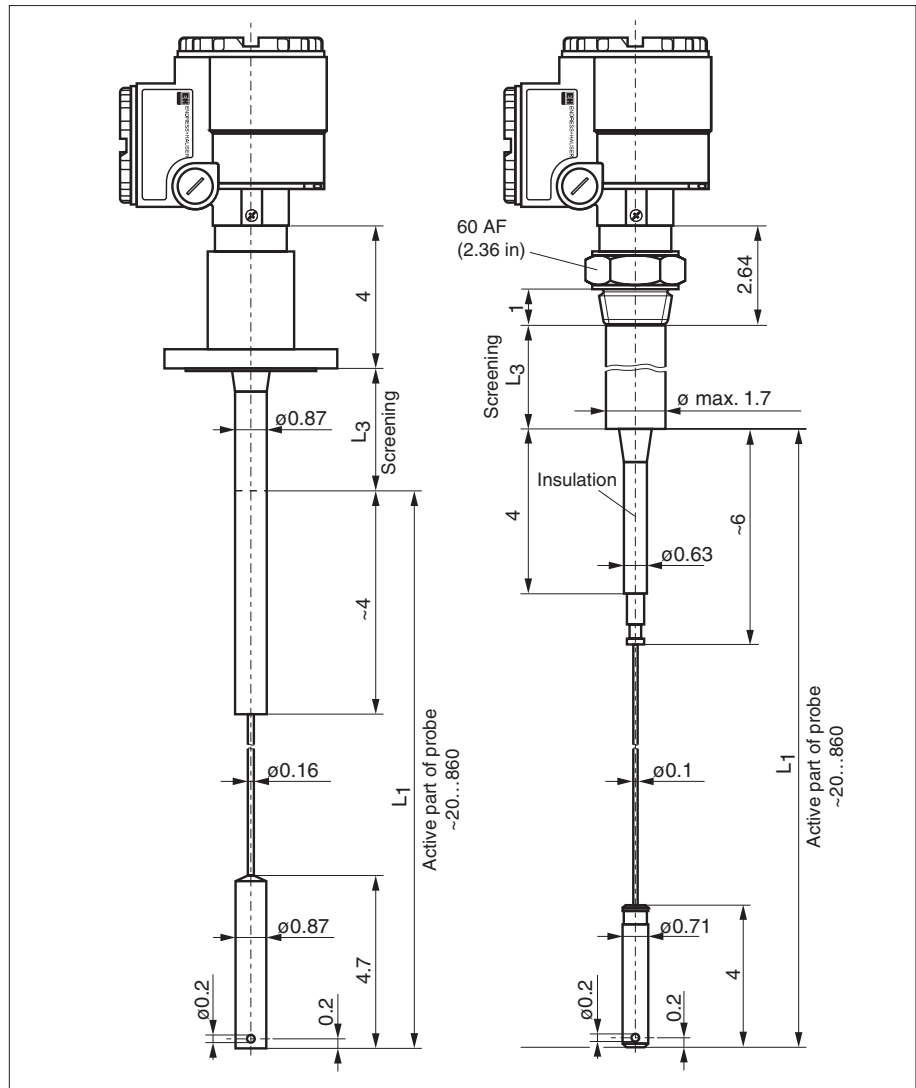

# Dimensions

## DC 11/16/21/26 AS Continued

All dimensions in inches.  
Threaded process connections: 1½ - 11½ NPT

### Probes with active build-up compensation (for limit detection, length always 6 in)

Partially insulated probes shown but fully insulated probes also available where the active part of build-up compensation is always uninsulated. Not available with ground tube.

Left: Rod probe  
DC 11 AS  
(fully insulated) or  
DC 16 AS  
(partially insulated)

Right: active build-up compensation combined with screening L3

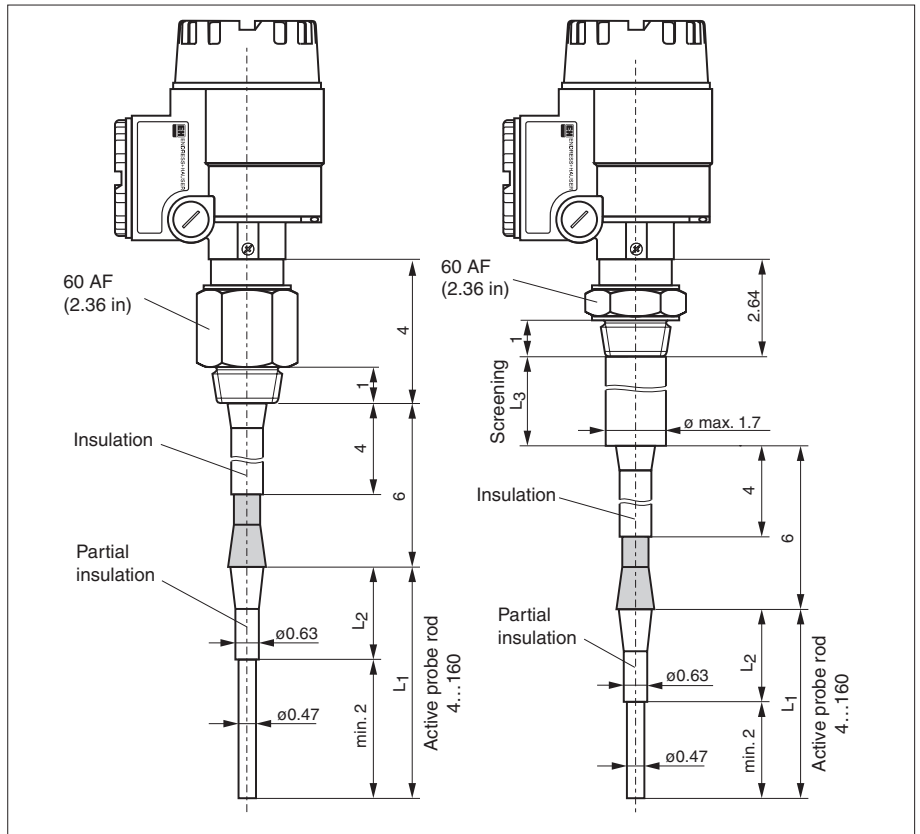

Left: Rope probe  
DC 21 AS  
(fully insulated)  
or DC 26 AS  
(partially insulated)

Right: active build-up compensation combined with screening L3

**L3**  
The screening (protection against condensation) is available in three standard lengths:  
L3 = 6 in  
L3 = 9 in  
L3 = 20 in

Other lengths on request  
L3 min. 4 in  
L3 max. 160 in

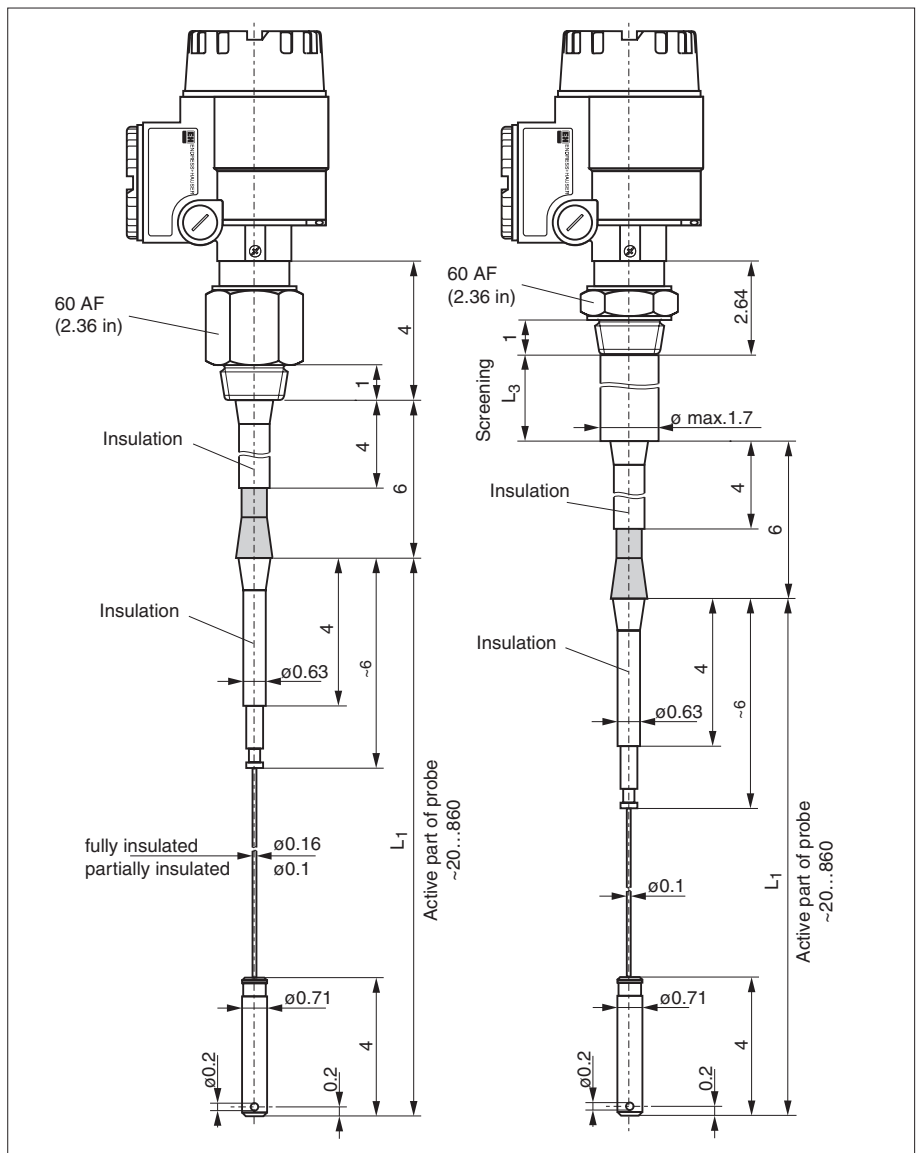

# Additional Process Connections and Accessories

Other process connections:

- Flange
- Triclamp 2"

\*h = 4 in for probes

- DC...AN
- DC...AS with fully insulated screening (protection against condensation)
- DC...AS with active build-up condensation

\*h = 1.85 in for probes

- DC...AS with uninsulated screening (protection against condensation)
- DC...AS with uninsulated screening and active build-up compensation

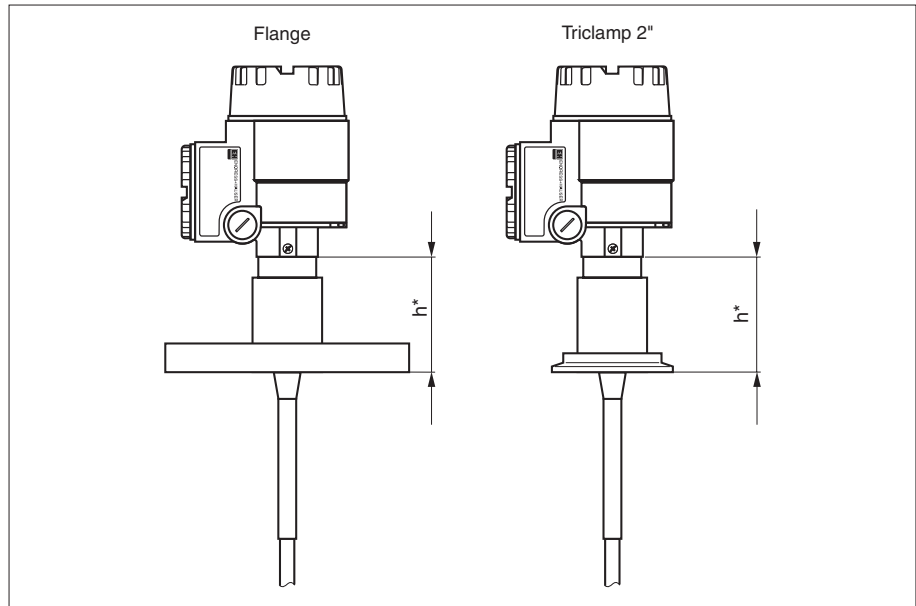

Additional equipment:

- A Temperature spacer for probes
- DC...AN
  - DC...AS with fully insulated screening (protection against condensation)
  - DC...AS with active build-up condensation

- B Temperature spacer for probes
- DC...AS with uninsulated screening (protection against condensation)
  - DC...AS with uninsulated screening and active build-up compensation

C Corrosion-resistant steel tag

- D Gas-tight gland for probes
- DC...AN
  - DC...AS with active build-up condensation

- E Gas-tight gland for probes
- DC...AS with uninsulated screening (protection against condensation)
  - DC...AS with uninsulated screening and active build-up compensation

- F Gas-tight gland for probes
- DC...AS with fully insulated screening (protection against condensation)

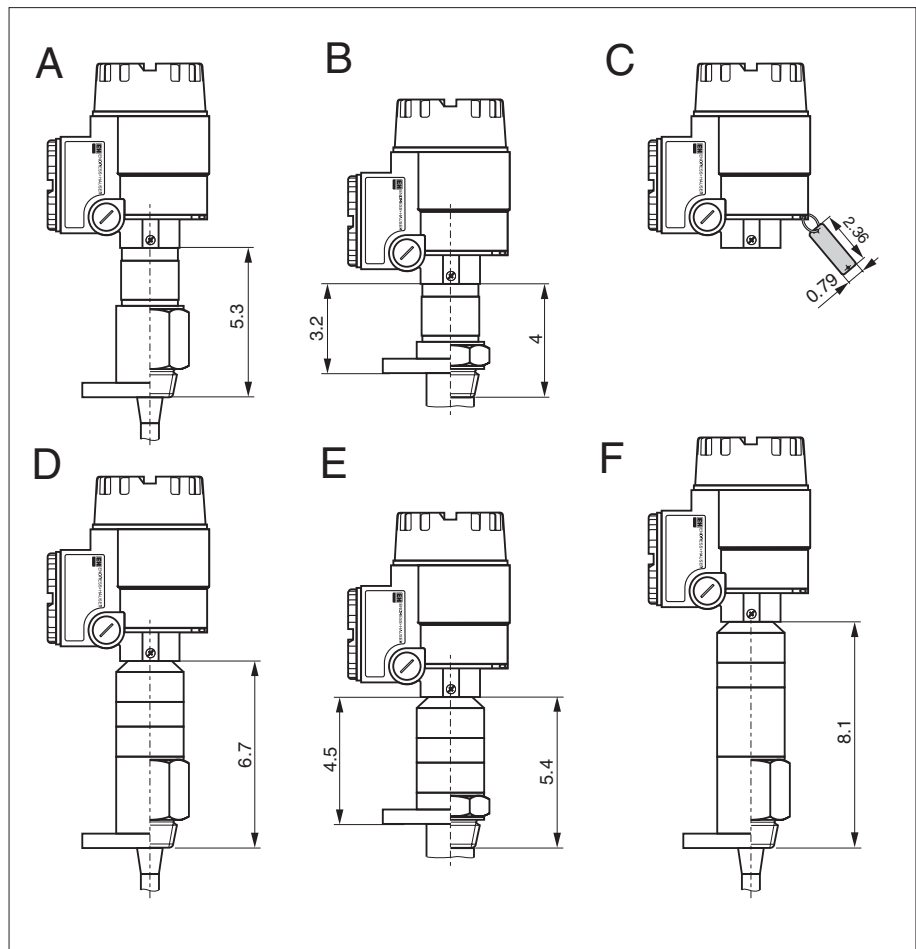

# Housing Dimensions

Housings in aluminium (Type T3) with separate connection compartment;

- RFI filter with small electronic inserts EC 17 Z, EC 37 Z, EC 47 Z and FEC 12 (IS),
- safety barriers with FEC 12 (XP).
- terminal connection module for FEC 22

With low cover for small electronic inserts EC...Z, with raised cover for electronic inserts FEC 12, FEC 14, FEC 22 with two cable entries, one sealed with a blind plug

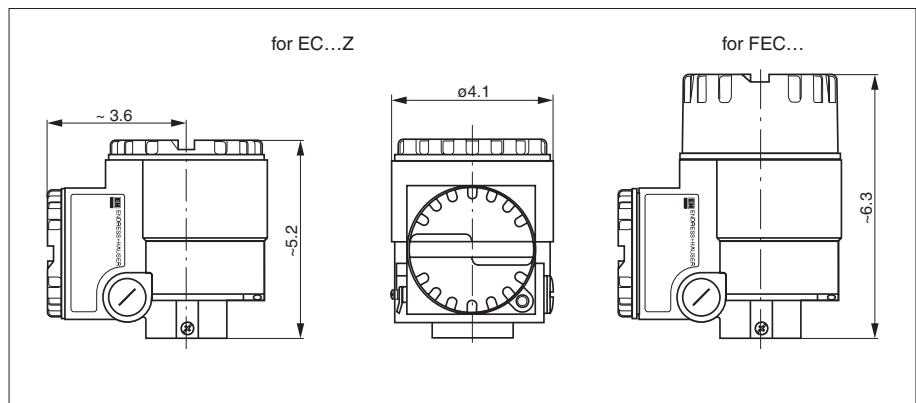

# Technical Data

## General information

|                   |   |
|-------------------|---|
| Manufacturer      | Endress+Hauser GmbH+Co. D-79689 Maulburg                    |
| Instrument family | Multicap  |
| Instrument types  | DC 11, 16, 21, 26 AN / AS                                   |
| Function          | Probes for capacitive level measurement and limit detection |

## Operating data

|                       |   |
|-----------------------|---|
| Operating pressure    | to 1450 psi depending on material - see below                   |
| Operating temperature | to 390 °F, depending on material - see below                    |
| Testing pressure      | to 2175 psi / temperature 70 °F by repetitive test as requested |

Permitted operating pressures  $p_e$  and temperatures  $T_B$

The graph **A** do not applies to:  
 - DC 21 AN / DC 21 AS,  
 - DC 26 AN / DC 26 AS,  
 - probes with active build-up compensation,  
 - probes with fully insulated screening.

The graph **B** applies to:  
 - DC 21 AN / DC 21 AS,  
 - DC 26 AN / DC 26 AS,  
 - probes with active build-up compensation,  
 - probes with fully insulated screening.

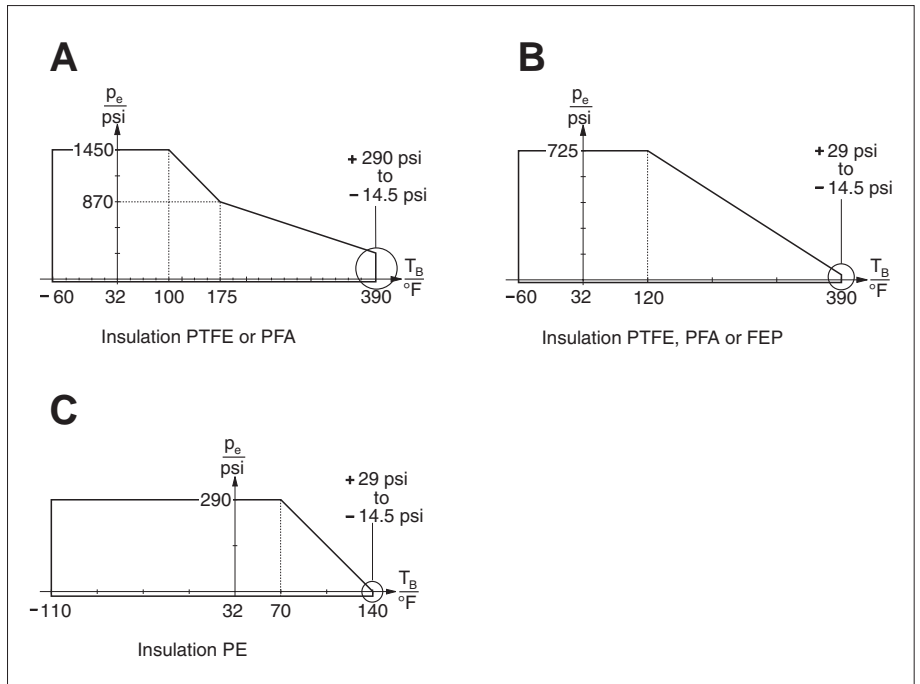

Mounting of the electronic insert as a function of operating temperature  $T_B$  and ambient temperature  $T_U$ :

- A Probe without temperature spacer
- B Probe with temperature spacer or gas-tight gland
- C Electronic insert in separate housing
- D Probe with temperature spacer or gas-tight gland and electronic insert in separate housing

The graphs A and B apply to **all** electronic inserts.

The graphs C and D apply to the small electronic inserts EC 17 Z, EC 37 Z, EC 47 Z

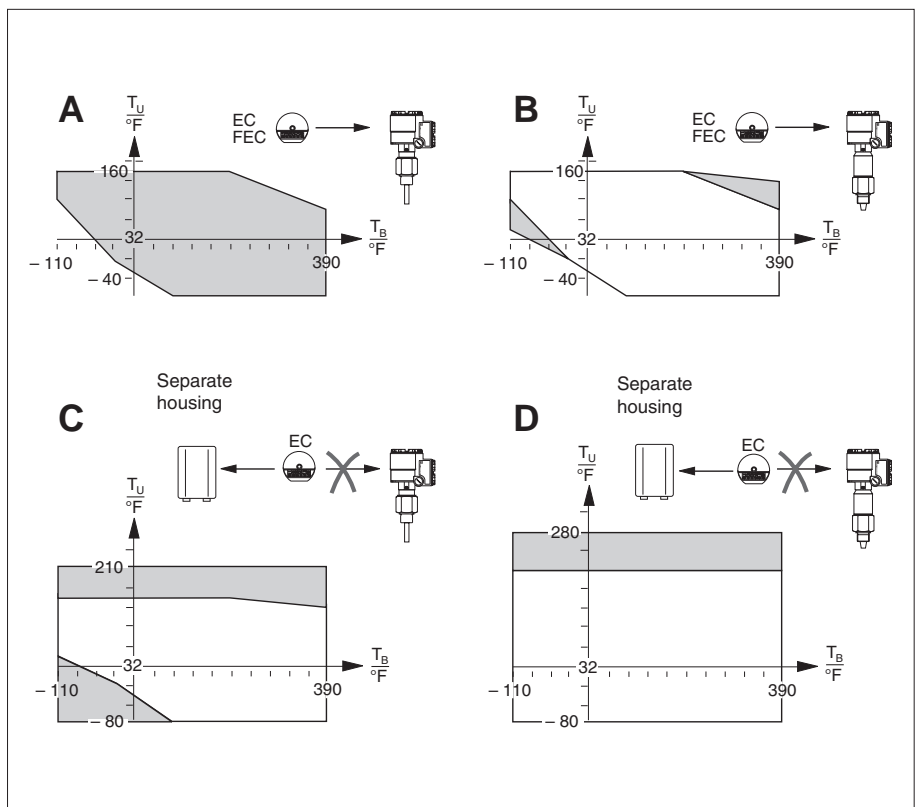

## Other Operating Data

|                               |                         |
|-------------------------------|-------------------------|
| Lateral load on the probe rod | see below               |
| Strain on the probe rope      | 45 lbs at 70 °F, static |

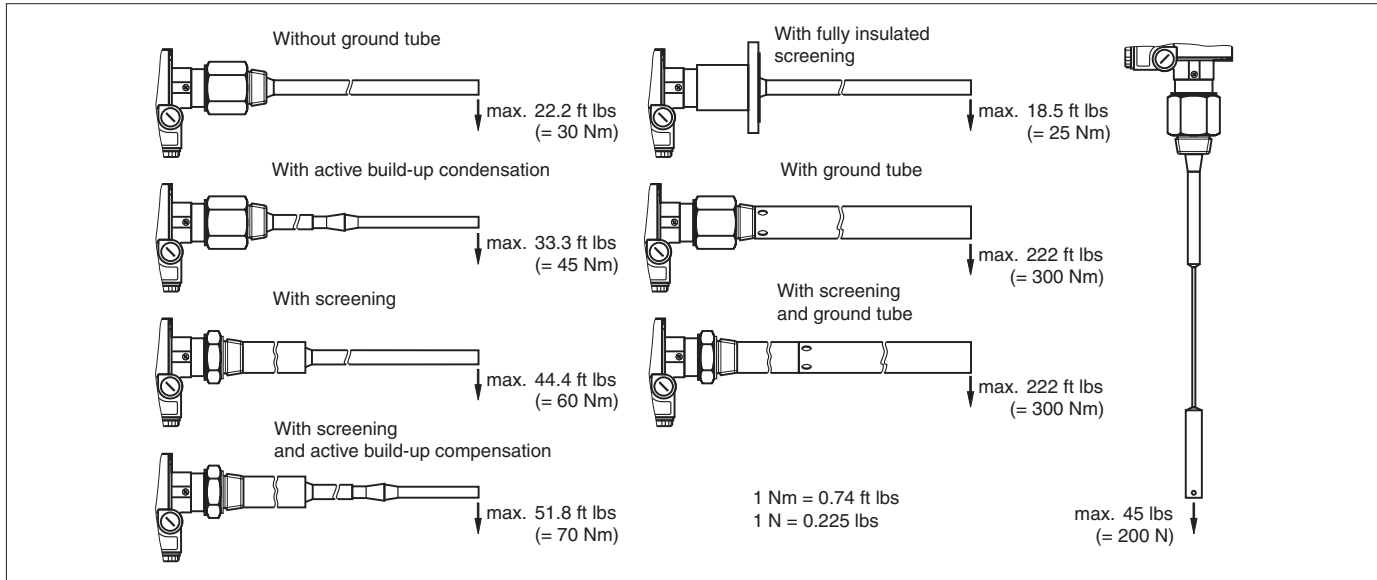

Permissible lateral load  
on the probes

### Probe lengths

|                              |  |
|------------------------------|--|
| Total length of a rod probe  | min. 4 in, max. 230 in, see dimensions   |
| Total length of a rope probe | min. 20 in, max. 1020 in, see dimensions |

### Capacitance values of the probe

|                              |               |
|------------------------------|---------------|
| Basic capacitance            | approx. 30 pF |
| Temperature spacer           | approx. 20 pF |
| Air-tight entry              | approx. 20 pF |
| Active build-up compensation | approx. 10 pF |

### Additional capacitances

|  |                               |  |
|--|-------------------------------|--|
| Probe 10 in from a<br>conductive vessel wall | insulated probe rod           | in air approx. 0.33 pF/in,<br>in water approx. 9.5 pF/in |
|  | uninsulated probe rod         | in air approx. 0.33 pF/in                                |
|  | insulated probe rope          | in air approx. 0.25 pF/in,<br>in water approx. 5 pF/in   |
|  | uninsulated probe rope        | in air approx. 0.25 pF/in                                |
|  | insulated tensioning weight   | in air approx. 2 pF<br>in water approx. 60 pF            |
|  | uninsulated tensioning weight | in air approx. 2 pF                                      |
| Rod probe in ground tube                     | insulated probe rod           | in air approx. 1.4 pF/in,<br>in water approx. 8.8 pF/in  |
|  | uninsulated probe rod         | in air approx. 1.3 pF/in                                 |
| Uninsulated screening                        | approx. 0.8 pF/in             |  |
| Fully insulated screening                    | approx. 1.5 pF/in             |  |

### Probe lengths for continuous measurement in conducting liquids

|   |  |
|---|--|
| EC with $C_{max.} = 2000$ pF<br>(EC 47 Z, FEC 12) | rope probe up to 315 in<br>(up to 1020 in in non-conducting liquids)<br>rod probe up to 230 in |
| EC with $C_{max.} = 4000$ pF<br>(EC 37 Z)         | rope probe up to 780 in<br>(up to 1020 in in non-conducting liquids)<br>rod probe up to 230 in |



## Other Operating Data

### Accuracy

|  |                           |        |  |
|--|---------------------------|--------|--|
| Length tolerances  | up to 40 in:              | +0 in, | -0.2 in rod probe,<br>-0.4 in rope probe |
|  | up to 120 in:             | +0 in, | -0.4 in rod probe,<br>-0.8 in rope probe |
|  | up to 240 in:             | +0 in, | -0.8 in rod probe,<br>-1.2 in rope probe |
|  | up to 1020 in:            | +0 in, | -1.6 in rope probe                       |
| The following specifications only apply to the capacitance of fully insulated probes when used in conductive liquids.<br><b>The deviation is insignificant for applications in non-conductive materials.</b> |                           |        |  |
| Linearity error in water   | < 1 % at 40 in length     |        |  |
| Temperature dependence of the probe rod  | < 0.1 % per K             |        |  |
| Pressure dependence of the probe rod   | approx. 1.4 % per 100 psi |        |  |
| Temperature dependence of the probe rope   | < 0.1 % per K             |        |  |
| Pressure dependence of the probe rope  | < 0.7 % per 100 psi       |        |  |

### Process connections

|                                 |               |
|---------------------------------|---------------|
| Parallel thread<br>1½ - 11½ NPT | ANSI B 1.20.1 |
| Triclamp coupling               | ISO 2852      |
| ANSI flanges                    | ANSI B 16.5   |

### Materials

|                                 |   |
|---------------------------------|---|
| Aluminium housing<br>(Type T3)  | GD-Al Si 10 Mg, DIN 1725,<br>with plastic coating (blue / grey) |
| Seal for housing cover          | O-ring of EPDM (elastomer)                                      |
| Temperature spacer              | Stainless steel AISI 304 or similar                             |
| Gas-tight gland                 | Stainless steel AISI 304  |
| Further material specifications | see Product Structure on Page 10...11                           |

# Product Structure

1 lb = 0.45 kg      1 in = 25.4 mm  
 1 oz = 28.35 g

|                                    |  |   |         |
|------------------------------------|--|---|---------|
| <b>DC 11 AN- MULTICAP DC 11 AN</b> | Fully isolated rod probe for standard applications       | Basic weight including process connection | 6,6 lbs |
| <b>DC 16 AN- MULTICAP DC 16 AN</b> | Partially insulated rod probe for standard applications  | 1½" NPT and housing, for rope probes with | 6,6 lbs |
| <b>DC 21 AN- MULTICAP DC 21 AN</b> | Fully isolated rope probe for standard applications      | tensioning weight                         | 7,3 lbs |
| <b>DC 26 AN- MULTICAP DC 26 AN</b> | Partially insulated rope probe for standard applications |   | 7,1 lbs |
| <b>DC 11 AS- MULTICAP DC 11 AS</b> | Fully isolated rod probe with protection features        |   | 6,6 lbs |
| <b>DC 16 AS- MULTICAP DC 16 AS</b> | Partially insulated rod probe with protection features   |   | 6,6 lbs |
| <b>DC 21 AS- MULTICAP DC 21 AS</b> | Fully isolated rope probe with protection features       |   | 7,3 lbs |
| <b>DC 26 AS- MULTICAP DC 26 AS</b> | Partially insulated rope probe with protection features  |   | 7,1 lbs |

### Certificate

- A For non-hazardous areas
- J FM IS Class I, II, III; Div. 1; Groups A-G
- K FM XP Class I; Div. 1; Groups A-D
- Q CSA IS Class I, II, III; Div. 1; Groups A-G
- R CSA XP Class I; Div. 1; Groups B-D
- Y Special version

### Build-up protection

|                      |   |         |                       |
|----------------------|---|---------|-----------------------|
| A                    | Ohne Abschirmung / Ansatzkompensation                           |         | additional weights    |
| DC 11, 16, 21, 26 AS |   |         |                       |
| B                    | 6 inch active guard,  | 316Ti   | 1,1 lbs               |
| M                    | 6 inch L3 screening,  | 316Ti   | 0,7 lbs               |
| N                    | 9 inch L3 screening,  | 316Ti   | 1,1 lbs               |
| P                    | 20 inch L3 screening,   | 316Ti   | 2,2 lbs               |
| R                    | .....inch (3 in...160 in) L3 screening,                         | 316Ti   | 0,11 lbs/in           |
| S                    | 6 inch L3 screening and 6 inch active guard,                    | 316Ti   | 1,8 lbs               |
| T                    | 6 inch L3 screening and 9 inch active guard,                    | 316Ti   | 2,2 lbs               |
| U                    | 20 inch L3 screening and 6 inch active guard,                   | 316Ti   | 3,3 lbs               |
| V                    | .....inch (3 in...160 in) L3 screening and 6 inch active guard, | 316Ti   | 0,11 lbs/in + 1,1 lbs |
| 1                    | 6 inch active guard,  | Alloy C | 1,1 lbs               |
| 2                    | .....inch (3 in...160 in) L3 screening,                         | Alloy C | 0,11 lbs/in           |
| 4                    | .....inch (3 in...160 in) L3 screening and 6 inch active guard, | Alloy C | 0,11 lbs/in + 1,1 lbs |
| 6                    | .....inch (3 in...160 in) L3 screening, fully insulated         |         | 0,06 lbs/in           |
| Y                    | Special version   |         |                       |

### Probe insulation

|                 |  |            |
|-----------------|--|------------|
| DC 11, 21 AN/AS |  |            |
| 1               | Fully insulated probe                        |            |
| DC 16 AN/AS     |  |            |
| F               | .....inch (3 in...160 in) L2, PTFE insulated | 0,09 oz/in |
| G               | .....inch (3 in...160 in) L2, PFA insulated  | 0,09 oz/in |
| H               | .....inch (3 in...160 in) L2, PE insulated   | 0,09 oz/in |
| DC 26 AN/AS     |  |            |
| K               | 1/10 inch diameter, rope type                |            |
| Y               | Special version                              |            |

### Active length L1, Material

|             |  |                            |
|-------------|--|----------------------------|
| DC 11 AN/AS |  |                            |
| A           | .....inch (4 in...860 in), PTFE+316Ti    | 0,9 oz/in                  |
| B           | .....inch (4 in...860 in), PE+steel      | 0,9 oz/in                  |
| C           | .....inch (4 in...860 in), PTFE+steel    | 0,9 oz/in                  |
| D           | .....inch (4 in...860 in), PFA+316Ti     | 0,9 oz/in                  |
| E           | .....inch (4 in...860 in), PTFE+Alloy C  | 0,9 oz/in                  |
| F           | .....inch (4 in...860 in), PFA+Alloy C   | 0,9 oz/in                  |
| G           | .....inch (4 in...860 in), PTFE+316Ti,   | with ground tube 2,7 oz/in |
| H           | .....inch (4 in...860 in), PFA+316Ti,    | with ground tube 2,7 oz/in |
| K           | .....inch (4 in...860 in), PE+steel,     | with ground tube 2,7 oz/in |
| L           | .....inch (4 in...860 in), PTFE+Alloy C, | with ground tube 2,7 oz/in |
| M           | .....inch (4 in...860 in), PFA+Alloy C,  | with ground tube 2,7 oz/in |

Continued Page 11

DC . . A . -

Product designation (first part)

# Product Structure (Continued)

## Active length L1, Material (continued)

|             |                                      |                                    |            |
|-------------|--------------------------------------|------------------------------------|------------|
| DC 16 AN/AS |                                      |                                    |            |
| N           | .....inch (4 in...860 in), 316Ti     |                                    | 0,8 oz/in  |
| P           | .....inch (4 in...860 in), steel     |                                    | 0,8 oz/in  |
| R           | .....inch (4 in...860 in), Alloy C   |                                    | 0,8 oz/in  |
| S           | .....inch (4 in...860 in), 316Ti     | and ground tube                    | 2,6 oz/in  |
| T           | .....inch (4 in...860 in), steel     | and ground tube                    | 2,6 oz/in  |
| U           | .....inch (4 in...860 in), Alloy C   | and ground tube                    | 2,6 oz/in  |
| DC 21 AN/AS |                                      |                                    |            |
| 1           | .....inch (4 in...860 in), PE+316Ti  | tensioning weight with anchor hole | 0,04 oz/in |
| 2           | .....inch (4 in...860 in), FEP+316Ti | tensioning weight with anchor hole | 0,04 oz/in |
| 3           | .....inch (4 in...860 in), PFA+316Ti | tensioning weight with anchor hole | 0,04 oz/in |
| DC 26 AN/AS |                                      |                                    |            |
| 4           | .....inch (4 in...860 in), 316Ti     | tensioning weight with anchor hole | 0,03 oz/in |
| 5           | .....inch (4 in...860 in), Alloy C   | tensioning weight with anchor hole | 0,03 oz/in |
| 9           | Special version                      |                                    |            |

## Process connection, Material

|   |                            |         |         |
|---|----------------------------|---------|---------|
| F | DN 40-51 (2"), ISO 2852,   | 304     |         |
|   | Tri-Clamp connection       |         | 1,1 lbs |
| M | 1½" NPT, Thread ANSI,      | steel   |         |
| N | 1½" NPT, Thread ANSI,      | 316Ti   |         |
| P | 1½" NPT, Thread ANSI,      | Alloy C |         |
| Y | Special version            |         |         |
| 5 | Flanged process connection |         |         |

## Flange type, Material

|     |   |          |
|-----|---|----------|
| AE1 | 2" 150 psi, RF, ANSI B16.5, steel       | 3,5 lbs  |
| AE2 | 2" 150 psi, RF, ANSI B16.5, 316Ti       | 3,5 lbs  |
| AE3 | 2" 150 psi, RF, ANSI B16.5, PTFE >316Ti | 3,5 lbs  |
| AG2 | 2" 300 psi, RF, ANSI B16.5, 316Ti       | 6,6 lbs  |
| AL1 | 3" 150 psi, RF, ANSI B16.5, steel       | 7,0 lbs  |
| AL2 | 3" 150 psi, RF, ANSI B16.5, 316Ti       | 7,0 lbs  |
| AL3 | 3" 150 psi, RF, ANSI B16.5, PTFE >316Ti | 7,0 lbs  |
| AN2 | 3" 300 psi, RF, ANSI B16.5, 316Ti       | 12,3 lbs |
| AP1 | 4" 150 psi, RF, ANSI B16.5, steel       | 11,9 lbs |
| AP2 | 4" 150 psi, RF, ANSI B16.5, 316Ti       | 11,9 lbs |
| AP3 | 4" 150 psi, RF, ANSI B16.5, PTFE >316Ti | 11,9 lbs |
| AR2 | 4" 300 psi, RF, ANSI B16.5, 316Ti       | 16,1 lbs |
| AV2 | 6" 150 psi, RF, ANSI B16.5, 316Ti       |          |
| A12 | 6" 300 psi, RF, ANSI B16.5, 316Ti       |          |
| YYY | Special version                         |          |

## Electronic insert

|   |   |                      |
|---|---|----------------------|
| E | with EC 17 Z, 2-wire PFM                            | 0,44 lbs             |
| G | with EC 37 Z, 2-wire PFM 33 kHz                     | 0,44 lbs             |
| H | with EC 47 Z, 2-wire PFM 1 MHz                      | 0,44 lbs             |
| K | with FEC 12, 2-wire 4...20 mA HART                  | 0,66 lbs• + 0,66 lbs |
| M | with FEC 22, 90...253 V AC, DPDT relay              | 0,66 lbs• + 0,66 lbs |
| N | with FEC 22, 10...55 V DC, 3-wire PNP               | 0,66 lbs• + 0,66 lbs |
| P | with FEC 14, PROFIBUS PA                            |                      |
| V | with FEC 14, local operation FHB 20 and PROFIBUS PA |                      |
| Y | Special version                                     |                      |

## Housing

|   |  |
|---|--|
| P | Aluminium, T3 Housing, PA-plug M12, IP66 |
| S | Aluminium, T3 Housing, Nema 4X, NPT ¾"   |
| Y | Special version                          |

## Option

|   |                                     |         |
|---|-------------------------------------|---------|
| 1 | Basic version                       |         |
| 2 | TAG number                          |         |
| 3 | Temperature spacer                  | 1,1 lbs |
| 4 | Temperature spacer and TAG number   | 1,1 lbs |
| 5 | Gas-tight probe seal                | 1,1 lbs |
| 6 | Gas-tight probe seal and TAG number | 1,1 lbs |
| 9 | Special version                     |         |

• Additional weight for raised cover

**Please don't forget:**

Length of

Screening            L3        in

Partial insulation    L2        in

Probe length         L1        in

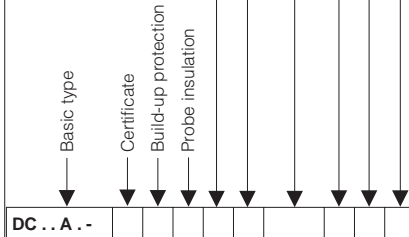

Complete product designation for DC . . AN, DC . . AS

## Accessories

- ❑ Slip-on sheet for partially insulated probes for increasing the switching safety for limit detection see Technical Information "Probe accessories"
- ❑ Rope shortening kit for fully insulated probes
- ❑ Rope shortening kit for partially insulated probes

## Supplementary Documentation

### Technical Information

- ❑ Probe accessories  
Technical Information TI 229F/00/en
- ❑ Electronic insert FEC 12  
Technical Information TI 250F/00/en
- ❑ Electronic insert FEC 14  
Technical Information TI 376F/00/en
- ❑ Electronic insert FEC 22  
Technical Information TI 251F/00/en
- ❑ Electronic insert EC 17 Z  
Technical Information TI 268F/00/en
- ❑ Electronic insert EC 37 Z, EC 47 Z  
Technical Information TI 271F/00/en
- ❑ Transmitters for limit detection and continuous level measurement on request

### Certificates

See product structure on page 10.

---

---

Endress+Hauser  
GmbH+Co. KG  
Instruments  
International  
P.O. Box 2222  
D-79574 Weil am Rhein  
Germany

Tel. (07621) 975-02  
Fax (07621) 975-345  
<http://www.endress.com>  
[info@ii.endress.com](mailto:info@ii.endress.com)

**Endress + Hauser**  
The Power of Know How

