



Level



Pressure



Flow



Temperature



Liquid
Analysis



Registration



Systems
Components



Services



Solutions

Technical Information

Soliphant T FTM260

Level limit switch

Cost-effective vibration limit switch for fine-grained solids

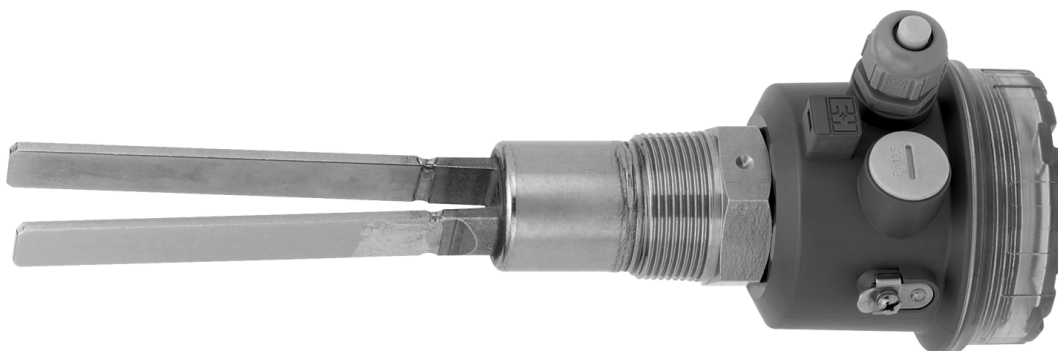

Application

Soliphant is a rugged level limit switch for use in silos containing fine-grained and powdery solids (up to 10 mm).

Its design and constructional materials also make it suitable for foodstuff applications.

Examples:

grain, flour, milk powder, cocoa, sugar, animal feed, washing powders, dyes, chalk, plaster, cement, plastic granulates

Your benefits

- No calibration: quick and low-cost start-up
- Insensitive to build-up: maintenance-free
- No mechanical moving parts: no wear, long operating life
- Various electronic inserts: optimum adaptability to the plant process
- External switching status: simple control

Table of content

Function and system design	3
Measuring principle	3
Measuring system	3
Output	4
Signal on alarm	4
Connectable load	4
Switch behaviour	4
Fail-safe mode	4
Power supply	5
Electrical connection	5
Supply voltage	5
Installation	6
Installation instructions	6
Environment	7
Ambient temperature	7
Storage temperature	7
Climate class	7
Degree of protection	7
Mechanical load on fork	7
Electromagnetic compatibility	7
Process	7
Medium temperature	7
Temperature diagram	7
Bulk density of material	7
Grain size of material	7
Operating pressure pe	7
Mechanical construction	8
Design, dimensions	8
Weight	8
Material	8
Process connection	8
Human interface	9
Display elements, operating elements	9
Ordering information	9
Product structure	9
Supplementary Documentation	9
Technical Information	9

Function and system design

Measuring principle

The symmetrical vibrating fork is excited to its resonant frequency. Vibration characteristics change when the fork is submerged in solid material. The change is registered by the electronics which actuate an electronic switch or relay.

The tip of the Soliphant fork is particularly sensitive, while the base of the fork is completely insensitive. This enables solids of very low density to be detected even with material build-up on the vessel walls.

The function of the electronic switch or relay and the LED is dependent on both the level and fail-safe mode selected

Level	Fail-safe mode	LED	Electronic inserts		
			FEM31	FEM32	FEM34
	Max.	●			
		☀			
	Min.	●			
		☀			
		●			

100-FTM260xx-15-06-xx-de-001

Soliphant FTM260 can be operated in both minimum or maximum fail-safe mode, i.e. the electronic switch opens or the relay de-energises on reaching the limit value, on a fault or on a loss of power.

Measuring system

Soliphant FTM260 is a compact limit switch to which miniature contactors, solenoid valves and programmable logic controllers (PLC) can be directly connected.

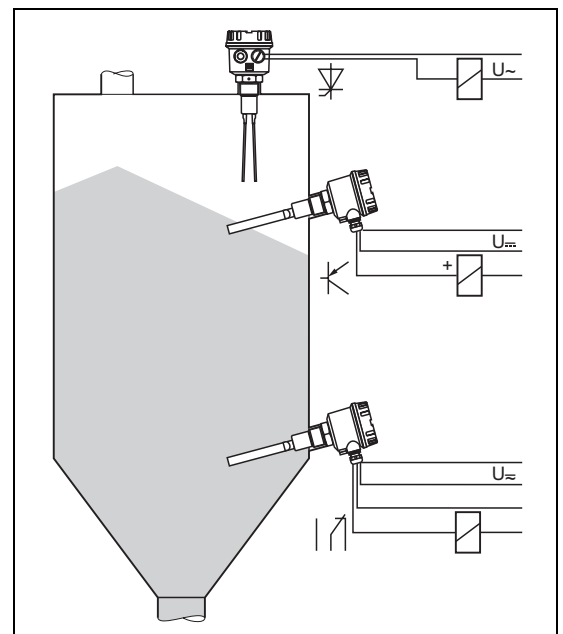

100-FTM260xx-14-06-xx-xx-001

Output

Signal on alarm	Output open or relay de-energised
Connectable load	<ul style="list-style-type: none"> ■ with FEM31 <i>(The load is switched directly via a thyristor in the power circuit)</i> Short-term (40 ms) max. 1.5 A, max. 375 VA at 250 V or max. 36 VA at 24 V (no short circuit protection), continuous max. 87 VA at 253 V, max. 8.4 VA at 24 V, min. 2.5 VA at 253 V (10 mA), min. 0.5 VA at 24 V (20 mA); Voltage drop across FEM 31 max. 12 V at load current >10 mA (max. 10 V at load current >20 mA); Quiescent current max. 3.8 mA with open thyristor ■ with FEM32 <i>(The load is switched via a transistor and separate PNP connection)</i> Short-term (1 s) max. 1 A, max. 55 V (cyclic overload and short-circuit protection), continuous max. 350 mA, max. 0.5 μF at 55 V, max. 1.0 μF at 24 V; Residual voltage <3 V (with closed transistor); Residual current <100 μA (with open transistor) ■ with FEM34 <i>(The load switched via a potential-free changeover contact)</i> I~ max. 6 A, U~ max. 253 V, P~ max. 1500 VA, $\cos \varphi = 1$, P~ max. 750 VA, $\cos \varphi > 0.7$; I- max. 6 A bis 30 V, I- max. 0.2 A to 125 V; Additional switching delay 0.3 s
Switch behaviour	approx. 0.6 s when covered, approx. 1.4 s when free
Fail-safe mode	Minimum or maximum fail-safe mode, switchable

Power supply

Electrical connection

Screw terminals on electronic insert for max. 2.5 mm² wire in end sleeve A 2.5 - 7 to DIN 46 228

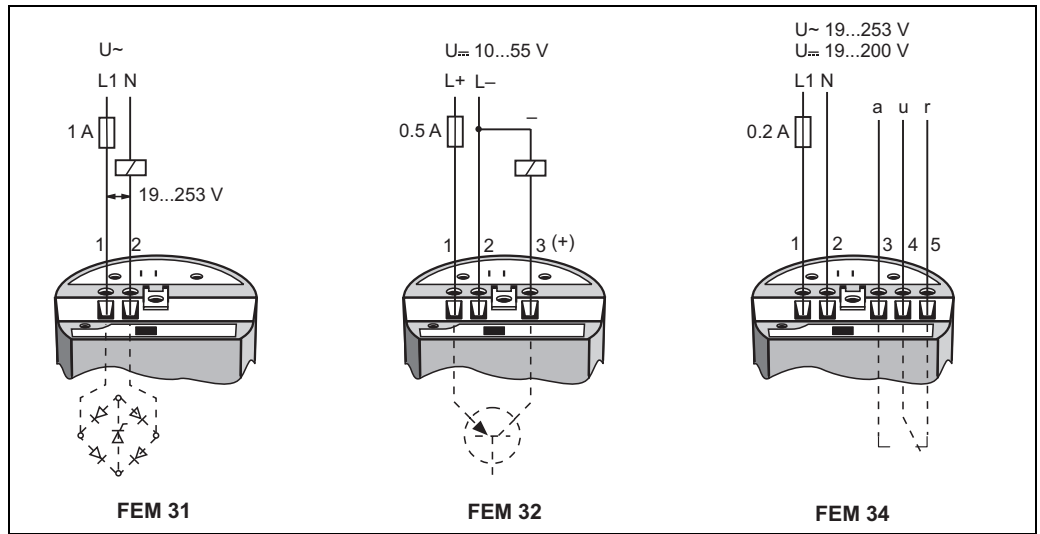

L00-FTM260xx-04-05-xx-xx-002

Electronic insert FEM31

Two-wire AC connection (thyristor)



Note!

Always connect in series with the load!

Check the following:

- the residual current in blocked state (up to 3.8 mA)
- that for low voltage
 - the voltage drop across the load such so that the minimum terminal voltage at the electronic insert (19 V) when blocked is not too low.
 - the voltage drop across the electronic insert when open is observed (up to 12 V).
- that a relay cannot de-energise with a retaining current below 3.8 mA.
If this is the case, a resistor should be connected parallel to the relay.

Electronic insert FEM32

Three-wire DC connection (transistor, PNP)

Designed to be connected to programmable logic controllers (PLC).
Positive signal at switching output of the electronic insert (PNP).

Electronic insert FEM34

Universal connection (relay, potential-free changeover contact)

Potential-free changeover contact.

Supply voltage

- Output with FEM31
Voltage at Terminals 1 and 2: 19...253 V, 50/60 Hz,
Current consumption (stand-by) max. 3.8 mA
- Output with FEM32
10...55 V, ripple max. 1.7 V, 0...400 Hz,
Current consumption max. 15 mA, protection against reverse polarity
- Output with FEM34
AC 19...253 V, 16...60 Hz or DC 19...200 V,
Current consumption max. 7 mA

Installation



Note!
All dimensions in mm
100 mm = 3.94 in

Installation instructions

Mounting location

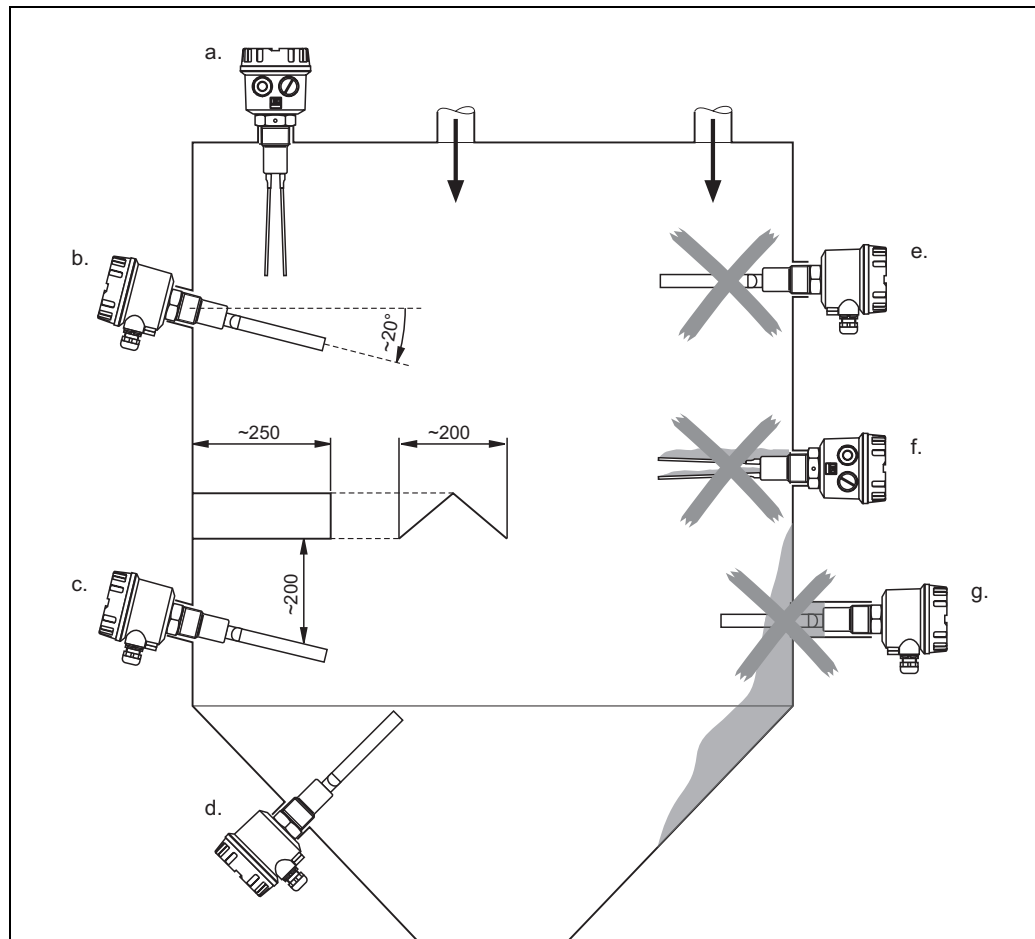

100-FTM260xx-11-06-xx-xx-001

Left: correct

- a. vertically mounted from above; any fork position
- b. laterally mounted with fork angled slightly downwards, nozzle length max. 60 mm
- c. with roof (length approx. 250 mm, width approx. 200 mm) to protect against collapsing mounds
- d. in discharge hopper

Right: incorrect

- e. in filling curtain
- f. false orientation of the fork (high load on the wide surface of the fork caused by discharging material; malfunction due to residual material)
- g. mounting nozzle too long

Orientation

The Soliphant FTM260 may be installed at any orientation in a vessel containing bulk solids.

Environment

Ambient temperature	-40 °C...+70 °C (-40°F...+160°F), see also "Temperature diagram"
Storage temperature	-40 °C...+85 °C (-40°F...+185°F)
Climate class	Climatic protection according to IEC 68, Part 2-38, Fig. 2a
Degree of protection	IP66 according to DIN 40050
Mechanical load on fork	600 N, lateral (on fine edges of tines), static
Electromagnetic compatibility	Interference Emission to EN 61326, Electrical Equipment Class B Interference Immunity to EN 61326, Annex A (Industrial) and NAMUR Recommendation NE 21 (EMC)

Process

Medium temperature	-40 °C...+150 °C (-40°F...+300°F), see also "Temperature diagram"
Temperature diagram	Permissible values for ambient temperature T_U at housing are dependent on the operating temperature T_B in the silo:

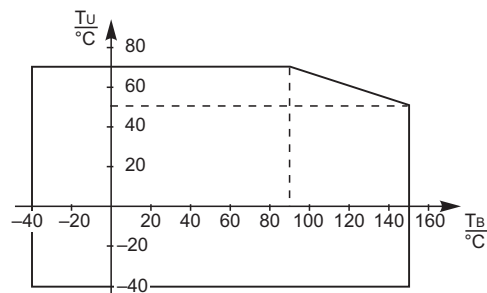

L00-FTM260xx-05-06-xx-xx-001

$$x \text{ °C} = (1.8 x + 32) \text{ °F}$$

Bulk density of material	min. 100 g/l
Grain size of material	up to 10 mm (0.4 in)
Operating pressure p_e	-1 bar...+16 bar (-14.5...+230 psi), burst pressure >40 bar

Mechanical construction



Note!
All dimensions in mm
100 mm = 3.94 in

Design, dimensions

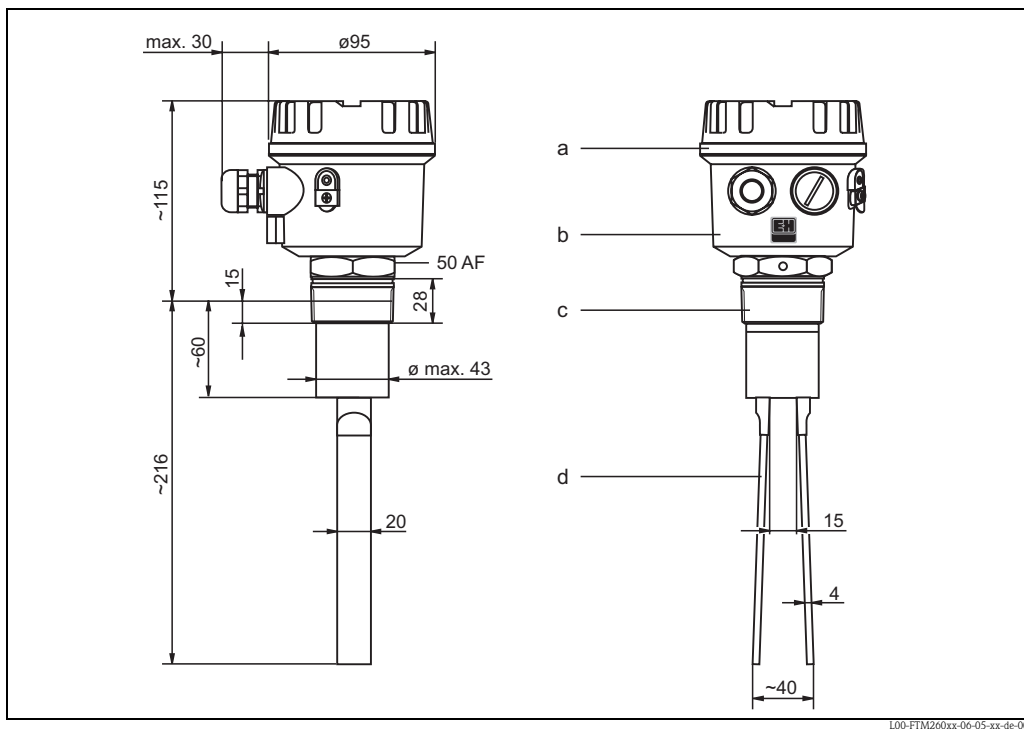

- The transparent cover shows the LED which indicates the switching mode
- Plastic housing,
Protection IP66, with cable gland versions
- Process connections:
 - R 1½, DIN 2999, (tapered)
in stainless steel
 - 1½" NPT, (tapered)
- Vibrating fork in solid stainless steel with high mechanical resistance to lateral loads

Weight approx. 1.1 kg with electronic insert

- Material**
- Process connection and vibrating fork: stainless steel AISI 304 (1.4301) and AISI 316Ti (1.4571)
 - Housing (F14): polyester
 - Transparent cover: polyamide
 - O-ring seal: EPDM
 - Cable gland M20x1.5: polyamide with Neoprene-CR seal

Process connection Tapered thread R 1½, DIN 2999;
Tapered thread 1½" NPT

Human interface

Display elements, operating elements

The plug-in electronic insert can be easily replaced with another electronic insert – without calibration

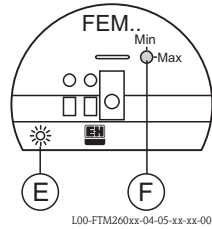

E = LED indicates switching status

F = Fail-safe mode is selected by turning a switch

Ordering information

Product structure

20		Process Connection			
G	Thread	DIN2999	R1½	304	
N	Thread	ANSI	NPT1½	304	
Y	Special version				
30		Electronics; Output			
Y	Special version				
1	FEM31	2-wire		19...253 V AC	
2	FEM32	3-wire	PNP	10...55 V DC	
4	FEM34	relay		19...253 V AC/200 V DC	
8	not selected				
40		Housing; Cable Entry			
B	F14	Polyester	NEMA4X	thread NPT½	
C	F14	Polyester	IP66	thread G½	
D	F14	Polyester	IP66	gland M20	
R	F14	Polyester	IP66	thread NPT½	
			CSA GP, non transparent cover		
S	F14	Polyester	IP66	gland M20	
			CSA GP, non transparent cover		
Y	Special version				
FTM260		Complete product designation			

Supplementary Documentation

Technical Information

General information on EMC
TI241F/00

International Head Quarter

Endress+Hauser
GmbH+Co. KG
Instruments International
Colmarer Str. 6
79576 Weil am Rhein
Deutschland

Tel. +49 76 21 9 75 02
Fax +49 76 21 9 75 34 5
www.endress.com
info@ii.endress.com

Endress+Hauser 
People for Process Automation