



Level



Pressure



Flow



Temperature



Liquid
Analysis



Registration



Systems
Components



Services



Solutions

Functional safety manual

Soliphant M with electronic insert FEM52

Level Limit Measuring System

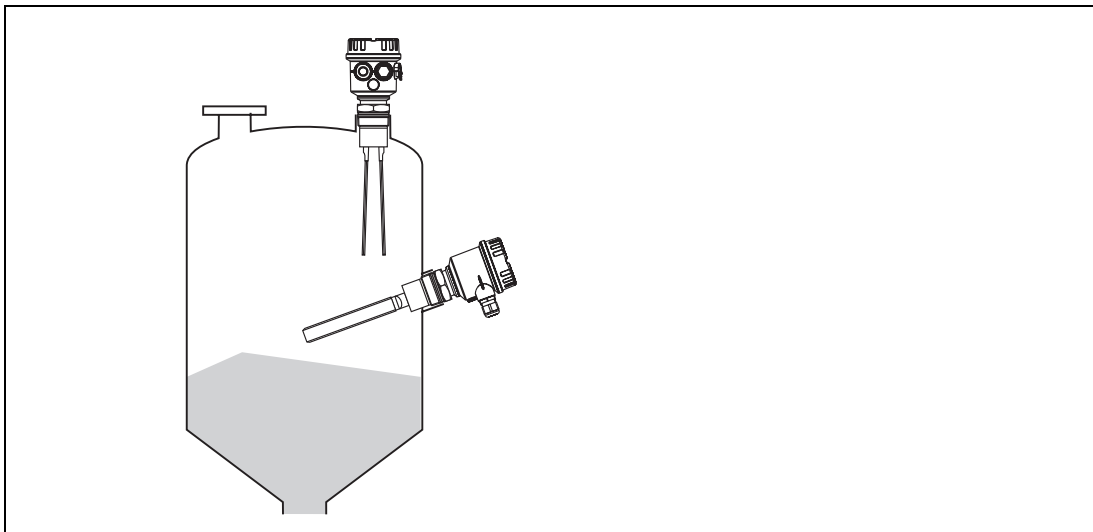

Application

Overflow protection or operating maximum detection of all types of solids in tanks to satisfy particular safety systems requirements to IEC 61508.

The measuring device fulfils the requirements concerning

- for safety functions up to SIL 2
- explosion protection by intrinsic safety or flameproof enclosure
- EMC to EN 61326 and NAMUR Recommendation NE 21.

Your benefits

- For overflow protection up to SIL 2
 - Independently assessed (Functional Assessment) by *exida* to IEC 61508
- No calibration
- Protected against outside vibration
- Easy commissioning

Table of contents

SIL declaration of conformity	3
Functional Assessment Report	4
Introduction	5
Structure of the measuring system with Soliphant M with FEM52	5
Level limit measuring system	5
Safety function	5
Supplementary device documentation	6
Settings and installation instructions	6
Installation instructions	6
Settings for Soliphant M with FEM52	7
Response in operation and failure	8
Failure rates of electrical components	8
Repair	8
Recurrent function tests of the measuring system	8
Appendix	9
Specific values and wiring options for the measuring system Soliphant M with FEM52	9
FMEDA Report	10

SIL declaration of conformity

SIL-05003b/00/a2

SIL-Konformitätserklärung

Funktionale Sicherheit nach IEC 61508

SIL Declaration of Conformity

Functional safety according to IEC 61508

Endress+Hauser GmbH+Co. KG, Hauptstraße 1, 79689 Maulburg

erklärt als Hersteller, dass der Füllstandgrenzschalter für Schüttgüter (Seriennummer XXXXXXXXXXXX) declares as manufacturer, that the level limit switch for bulk solids (Serial number XXXXXXXXXXXX)

Solphant M FTM5.- + Electronic insert FEM52

für den Einsatz in Schutzeinrichtungen entsprechend der IEC 61508 geeignet ist, wenn die Sicherheitshinweise und nachfolgende Parameter beachtet werden:
is suitable for the use in safety-instrumented systems according to IEC 61508, if the safety instructions and following parameters are observed:

Gerät/Product	Solphant M +FEM52
Schutzfunktion/Safety Function	Überfüllsicherung/overflow protection
SIL	
Prüfintervall/Proof test interval	≤ 1 Jahr/year
Gerätetyp/Device type	B
HFT	0 (einkanalige Verwendung/single channel use)
SFF	>90%
PFD _{avg} ¹⁾	<0,025x10 ⁻²
λ _{du}	58 FIT
λ _{dd}	39 FIT
λ _{su}	487 FIT
λ _{sd}	39 FIT
MTBF _{tot} ²⁾	158 Jahre/years

¹⁾ Die Werte entsprechen SIL 2 nach ISA S84.01 / The values comply with SIL 2 according to ISA S84.01
²⁾ gemäß Siemens SN29500, einschließlich Fehlern, die außerhalb der Sicherheitsfunktion liegen/
according to Siemens SN29500, including faults outside the safety function

Das Gerät wurde in einem vollständigen Functional Safety Assessment unabhängig bewertet.
The device was assessed independently in a complete Functional Safety Assessment.

Maulburg, 21.02.2006

Endress+Hauser GmbH+Co. KG

i.V. 
Leitung Zertifizierungsstelle
Management Certification Department

i.V. 
Leitung Entwicklungsprojekt
Management R&D Project

Endress+Hauser 
People for Process Automation



Level



Pressure



Flow



Temperature



Liquid Analysis



Registration



Systems Components



Services



Solutions

Functional Assessment Report



Management summary

The Functional Safety Assessment of the Endress + Hauser Maulburg, Soliphant M development project, performed by *exida* consisted of the following activities:

- *exida* assessed the development process used by E+H Maulburg for this development project against the objectives of IEC 61508 parts 1 to 3.
All objectives have been successfully considered in the E+H Maulburg development process for the level switch Soliphant M.
- *exida* assessed the development process by an detailed development audit which investigated the compliance with IEC 61508 of the processes, procedures and techniques as implemented for the E+H Maulburg level switch Soliphant M development. The investigation was executed using subsets of the IEC 61508 requirements tailored to the work scope of the development team.
The objectives of the standard are fulfilled by the E+H Maulburg, for the level switch Soliphant M development project.
- *exida* assessed the safety case prepared by E+H Maulburg against the technical requirements of IEC 61508 for a type B subsystem.
The safety case demonstrated the fulfillment of the technical requirements of IEC 61508 for the level switch Soliphant M development project.

Some areas for improvement were identified which are generally required to formally show the compliance to IEC 61508. However, because of the size of the project (limited number of people) and the low complexity / limited size of the product, E+H was able to demonstrate that the *objectives of the related areas have been successfully met*.

The result of the Functional Safety Assessment can be summarized by the following statements:

The audited E+H development process tailored and implemented by the Soliphant M project related to Hardware and Software development comply with the relevant safety management requirements of IEC 61508 SIL 2.

The assessment of the FMEDA, which is performed according to IEC 61508, has shown that the level switch Soliphant M has a PFD_{AVG} within the allowed range for SIL 2 (HFT=0) according to table 2 of IEC 61508-1 and a Safe Failure Fraction (SFF) of more than 90%.

This means that the level switch Soliphant M is capable for use in SIL 2 applications.

Audun Opem, Senior Project Manager

Dipl.-Ing. (Univ.) Rainer Faller, Principal Partner

Introduction



Note!

For general information about SIL please refer to: www.endress.com/sil

and in the Competence Brochure CP002Z "Safety in the Process Industry – reducing risks with SIL"

Structure of the measuring system with Soliphant M with FEM52

Level limit measuring system

The measuring system is displayed in the following diagram (example).

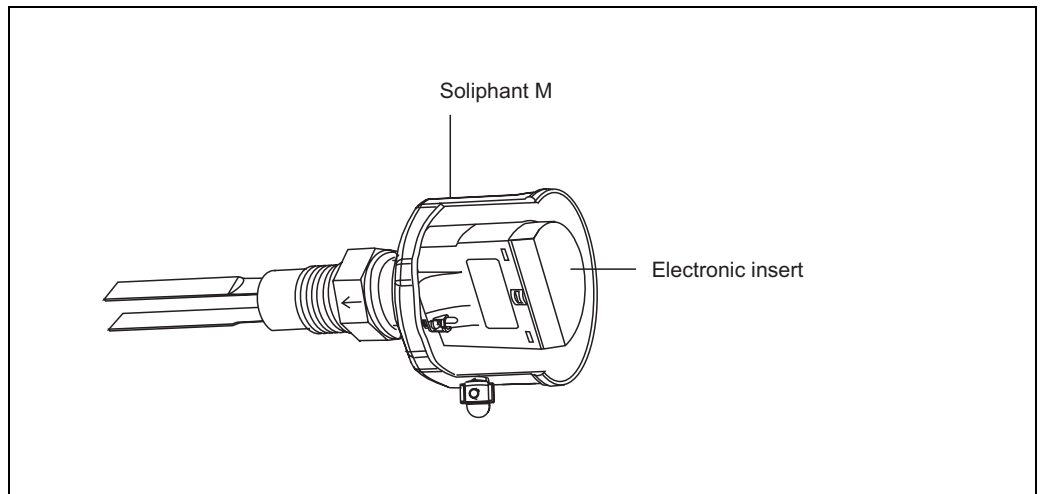

L00-FIM5xxxx-16-06-xxx-en-001

Soliphant M with electronics insert FEM52: three-wire DC connection (PNP) with transistor output

Safety function

The safety function only applies to MAX safety (overflow protection).

The transistor output is blocked when:

- The switch point is exceeded (level exceeds response height)
- A fault occurs
- The mains voltage fails

The measuring range of Soliphant M depends on the medium, mounting location and fork length.

The detection range is within the length of the fork and depends on the weight of the medium and the resulting type of fork:

- Standard fork with a length of 155 mm (Density of medium ≥ 10 g/l) and
- Short fork with a length of 100 mm (Density of medium ≥ 50 g/l)

Permitted versions of the Soliphant M with FEM52 for the safety function

The following combinations are permitted for the measuring system:

- FTM50-#####2#####
- FTM51-#####2#####
- FTM52-#####2#####

Permitted instrument types (# = all instrument versions permitted excepting 9 and Y)

- Valid FW version (firmware): V01.01.00 or higher
- Valid HW version (hardware): V02.00 or higher

Safety function data

The **mandatory settings** and data for the safety function can be found in the Appendix (Page 9).

The measuring system reacts in ≤ 0.9 s.



Note!

MTTR is set at 8 hours under the condition that the electronics insert is on stock.

Safety systems **without a self-locking function** must be monitored or set to an otherwise safe state after carrying out the safety function within MTTR.

Supplementary device documentation

The following must be available for the measuring system:

	Technical Information	Operating Instructions
Soliphant M	FTM50, FTM51, FTM52 TI392F/00	FTM50, FTM51 KA229F/00
		FTM52 KA230F/00
Relevant contents	Connection data, Installation instructions	Setting, configuration, remarks, function tests

Settings and installation instructions

Installation instructions

Please refer to the Operating Instructions (KA) for information regarding the correct installation of Soliphant M with FEM52.

Since the application conditions have an effect on the safety of the measurement, pay attention to the notes in the Technical Information (TI) and Operating Instructions (KA).

Refer to the following documentation for instructions on setting the instruments:

	Setting description in documentation
Soliphant M	FTM50, FTM51 KA229F/00
	FTM52 KA230F/00

Settings for Soliphant M with FEM52

Switch setting for the safety function:

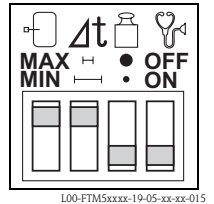

One switch for safety mode

- MAX Overfill protection
- MIN Dry running protection



One switch for switching delay

- ⇐ 0.5 s when covered, 1.5 s when uncovered (short fork 1 s)
- ⇐ 5 s when covered, 5 s when uncovered



One switch for bulk density/density setting

- ≥ 50 g/l standard fork, ≥ 200 g/l short fork (high bulk density)
- ≥ 10 g/l standard fork, ≥ 50 g/l short fork (low bulk density)



One switch for diagnosis

- OFF Diagnosis of abrasion and build-up switched OFF.
- ON Diagnosis of abrasion and build-up switched ON.
 - For additional density setting to high bulk density: abrasion and build-up are indicated per LED at the electronic insert only
 - For additional density setting to low bulk density: output of "signal on alarm" for abrasion and build-up

Connectable load:

- Load switched via transistor and separate PNP connection, max. 55 V
- Load current max. 350 mA (cyclical overload and short-circuit protection)
- Residual current < 100 μ A (with transistor blocked)
- Capacitive load max. 0.5 μ F at 55 V, max. 1.0 μ F at 24 V
- Residual voltage < 3 V (for transistor switched through)

Overvoltage protection FEM52: overvoltage category III



Note!

The SIL evaluation for the Soliphant M comprises the complete device, including the electronics insert, the tuning fork with piezo drive, the process connection and the internal wiring.

In applications with extremely strong external vibrations > 0.05 g^2/Hz **and** light weight bulk solids < 600 gr/l a functional test is recommended!

It is recommended to leave the switching elements following the overfill protection in the safe state until the alarm signal has been acknowledged.



Caution!

Changes to the settings at the electronic insert FEM52 after measuring system start-up can impair the safety function!

Response in operation and failure

The response in operation and failure is described in the following documentation:

	Setting description in documentation
Soliphant M	FTM50, FTM51 KA229F/00
	FTM52 KA230F/00

Failure rates of electrical components

The underlying failure rates of electrical components are specified for the useful lifetime according to IEC 61508-2 Section 7.4.7.4. Note 3.

Repair

If a SIL-marked device that has been operated in a functional safety application fails, the "Declaration of Hazardous Material and De-Contamination" form containing the appropriate information "Used as a SIL device in a Safety Instrumented System" must be enclosed with the defective device when it is returned.

Recurrent function tests of the measuring system

The operativeness of the overfill protection must be checked periodically if the PFD_{avg} values given in the Appendix are used.

The check must be carried out in such a way that it is proven that the overfill protection functions perfectly in interaction with all components. This is guaranteed when the response height is approached in a filling process. If it is not practical to fill to the response height, suitable simulation of the level or of the physical measuring effect must be used to make the level sensor respond. If the operativeness of the level sensor/transmitter can be determined otherwise (exclusion of faults that impair function), the check can also be completed by simulating the corresponding output signal.



Caution!

Note the following points for the function test:

- Transistor output switching can be checked by using a hand multimeter at the terminals or by observing the overfill protection elements (e.g. horn, adjuster).
- As a positive test result, a covered tuning fork must be detected and trigger the alarm for overfill protection.
- **If fork covering is not detected during the recurrent test, the monitored process must be set to a safe state by means of additional or other measures and/or kept in the safe state until the safety system is repaired.**

Appendix

Specific values and wiring options for the measuring system Soliphant M with FEM52

The table show values and wiring options relevant to safety for the measuring system.

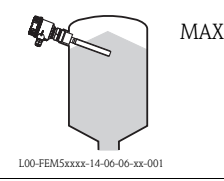
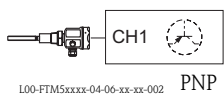
1oo1 architecture	
Evaluated transmitter (FEM52)	
SIL	SIL 2
HFT	0
SFF	90 %
PFD _{avg} (low demand mode of operation)	0.025×10^{-2}
λ_{sd}	39 FIT
λ_{su}^2	487 FIT
λ_{dd}	39 FIT
λ_{du}	58 FIT
MTBF	158 years
Wiring scheme	
Recurrent test e.g. approaching level	T_1 (test interval) as required; see table below

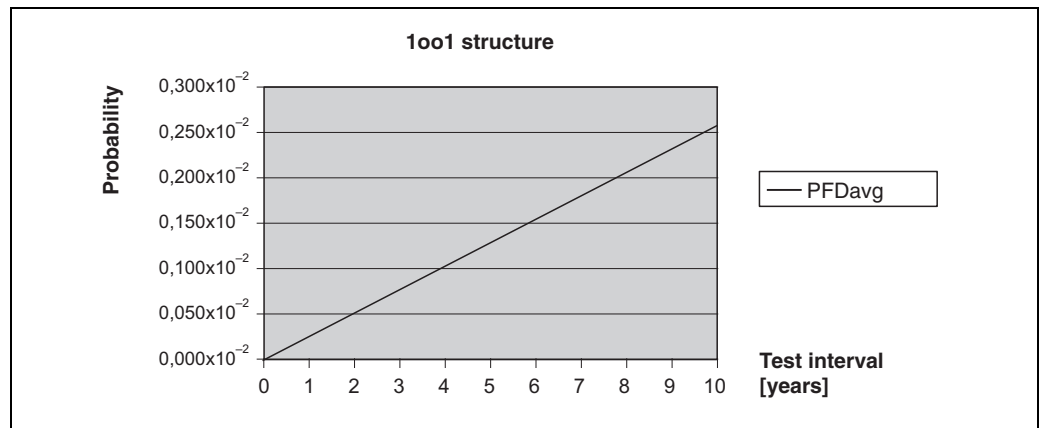

FMEDA Report



Management summary

This report summarizes the results of the hardware assessment carried out on the level limit switch Soliphant M with transistor (PNP) output FEM52 and software version V01.00.00.

The hardware assessment consists of a Failure Modes, Effects and Diagnostics Analysis (FMEDA). A FMEDA is one of the steps taken to achieve functional safety assessment of a device per IEC 61508. From the FMEDA, failure rates are determined and consequently the Safe Failure Fraction (SFF) is calculated for the device. For full assessment purposes all requirements of IEC 61508 must be considered.

The failure rates used in this analysis are the basic failure rates from the Siemens standard SN 29500.

According to table 2 of IEC 61508-1 the average PFD for systems operating in low demand mode has to be $\geq 10^{-3}$ to $< 10^{-2}$ for SIL 2 safety functions. A generally accepted distribution of PFD_{AVG} values of a SIF over the sensor part, logic solver part, and final element part assumes that 35% of the total SIF PFD_{AVG} value is caused by the sensor part. For a SIL 2 application the total PFD_{AVG} value of the SIF should be smaller than 1,00E-02, hence the maximum allowable PFD_{AVG} value for the sensor part would then be 3,50E-03.

The level limit switch Soliphant M with transistor (PNP) output FEM52 is considered to be a Type B' component with a hardware fault tolerance of 0.

For Type B components with a hardware fault tolerance of 0 the SFF shall be > 90% according to table 3 of IEC 61508-2 for SIL 2 (sub-) systems.

Endress+Hauser together with *exida.com* performed a qualitative analysis of the mechanical parts of the level limit switch Soliphant M with transistor (PNP) output FEM52. This analysis was used by *exida* to calculate the failure rates of the sensor element using different failure rate databases ([N5], [N6], [N7] and *exida*'s experienced-based data compilation) for the different components of the sensor element (see [R1]). The results of the quantitative analysis were used for the calculations described in section 5.2.

Table 1 Failure rates according to IEC 61508

λ_{red}	λ_{det}^2	λ_{det}	λ_{du}	SFF	DC _S ³	DC _D ³
39 FIT	487 FIT	39 FIT	58 FIT	90%	7%	40%

Table 2: Summary – PFD_{AVG} values

TTProof = 1 year	TTProof = 5 years	TTProof = 10 years
PFD _{AVG} = 2,52E-04	PFD _{AVG} = 1,26E-03	PFD _{AVG} = 2,52E-03

The boxes marked in green (■) mean that the calculated PFD_{AVG} values are within the allowed range for SIL 2 according to table 2 of IEC 61508-1 and table 3.1 of ANSI/ISA-84.01-1996 and do fulfill the requirement to not claim more than 35% of this range, i.e. to be better than or equal to 3,50E-03.

Because the Safe Failure Fraction (SFF) is above 90% for all considered versions, also the architectural constraints requirements of table 3 of IEC 61508-2 for Type B subsystems with a Hardware Fault Tolerance (HFT) of 0 are fulfilled.

¹ Type B component: "Complex" component (using micro controllers or programmable logic); for details see 7.4.3.1.3 of IEC 61508-2.

² Note that the SU category includes failures that do not cause a spurious trip

³ DC means the diagnostic coverage (safe or dangerous).



Failure Modes, Effects and Diagnostic Analysis

Project:

Level limit switch Soliphant M with transistor (PNP) output FEM52
Applications with level limit detection in solids (MAX detection)

Customer:

Endress+Hauser GmbH+Co. KG
Maulburg
Germany

Contract No.: E+H 03/03-22

Report No.: E+H 03/03-22 R030

Version V1, Revision R1.0, July 2005

Stephan Aschenbrenner



The failure rates listed above do not include failures resulting from incorrect use of the level limit switch Soliphant M with transistor (PNP) output FEM52, in particular humidity entering through incompletely closed housings or inadequate cable feeding through the inlets.

The listed failure rates are valid for operating stress conditions typical of an industrial field environment similar to IEC 60654-1 class C (sheltered location) with an average temperature over a long period of time of 40°C. For a higher average temperature of 60°C, the failure rates should be multiplied with an experience based factor of 2.5. A similar multiplier should be used if frequent temperature fluctuation must be assumed.

A user of the level limit switch Soliphant M with transistor (PNP) output FEM52 can utilize these failure rates in a probabilistic model of a safety instrumented function (SIF) to determine suitability in part for safety instrumented system (SIS) usage in a particular safety integrity level (SIL). A full table of failure rates is presented in section 5.2 along with all assumptions.

It is important to realize that the "no effect" failures and the "annunciation" failures are included in the "safe undetected" failure category according to IEC 61508. Note that these failures on its own will not affect system reliability or safety, and should not be included in spurious trip calculations.

The failure rates are valid for the useful life of the level limit switch Soliphant M with transistor (PNP) output FEM52, which is estimated to be between 8 and 12 years (see Appendix 3).

International Head Quarter

Endress+Hauser
GmbH+Co. KG
Instruments International
Colmarer Str. 6
79576 Weil am Rhein
Deutschland

Tel. +49 76 21 9 75 02
Fax +49 76 21 9 75 34 5
www.endress.com
info@ii.endress.com

Endress+Hauser 

People for Process Automation

