



Level



Pressure



Flow



Temperature



Liquid
Analysis



Registration



Systems
Components



Services



Solutions

Operating instructions

iTEMP[®] Pt TMT180

Temperature head transmitter

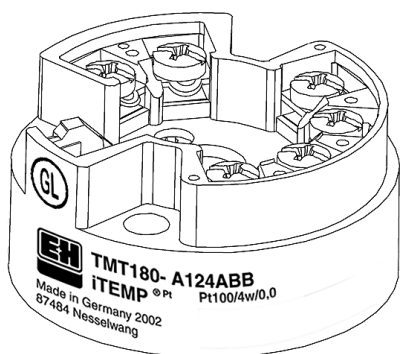

Safety message

Instructions and procedures in the operating instructions may require special precautions to ensure the safety of the personnel performing the operations. Information that potentially raises safety issues is indicated by safety pictograms and symbols. Please refer to the safety messages before performing an operation preceded by pictograms and symbols, see chapter 1.5.

Though the information provided herein is believed to be accurate, be advised that the information contained herein is NOT a guarantee of satisfactory results. Specifically, this information is neither a warranty nor guarantee, expressed or implied, regarding performance; merchantability, fitness, or other matter with respect to the products; and recommendation for the use of the product / process information in conflict with any patent. Please note that the manufacturer reserves the right to change and / or improve the product design and specifications without notice.



Warning!

Failure to follow these installation guidelines could result in death or serious injury.

– Make sure only qualified personnel perform the installation.

Process leaks could result in death or serious injury.

– Do not remove the thermowell while in operation.

– Install and tighten thermowells and sensors before applying pressure.

Electrical shock could cause death or serious injury.

– Use extreme caution when making contact with the leads and terminals.

Brief overview

Using the following short form instructions you can commission your system easily and swiftly:

Safety notes	→ Page 4
⇓	
Installation	→ Page 7
⇓	
Wiring	→ Page 10
⇓	
Display and operating elements Preparing the communication with PC configuration software	→ Page 12
⇓	
Instrument configuration (including a description of the unit functions) A complete description of all the functions as well as a detailed overview of the functionality can be found in this chapter.	→ Page 13

Table of contents

1	Safety notes	4
1.1	Designated use	4
1.2	Installation, commissioning and operation	4
1.3	Operational safety	5
1.4	Returns	5
1.5	Safety pictograms and symbols	5
2	Identification	6
2.1	Unit identification	6
2.2	Delivery contents	7
2.3	Registered trademarks	7
3	Installation	7
3.1	Installation conditions	7
3.2	Installation	8
4	Wiring	10
4.1	Overview	10
4.2	Measurement unit connection	10
4.3	Potential grounding	11
4.4	Ground the Transmitter	11
5	Operation	12
5.1	Communication	12
6	Commissioning	13
6.1	Installation and function check	13
6.2	Switch on the device	13
6.3	Configuration	13
7	Maintenance	15
8	Accessories	15
9	Trouble-shooting	16
9.1	Trouble-shooting instructions	16
9.2	Application errors without messages	16
9.3	Spare parts	17
9.4	Returns	17
9.5	Disposal	17
9.6	Software history	17
10	Technical Data	18
	Index	23

1 Safety notes

Safe and secure operation of the head transmitter can only be guaranteed if the operating instructions and all safety notes are read, understood and followed.

1.1 Designated use

- The unit is a universal, presettable temperature head transmitter for resistance thermometer (RTD). The unit is constructed for mounting in a connection head (DIN form B) or field housing.
- The manufacturer cannot be held responsible for damage caused by misuse of the unit.

1.2 Installation, commissioning and operation

The unit is constructed using the most up-to-date production equipment and complies to the safety requirements of the local guidelines. The temperature transmitter is fully factory tested according to the specifications indicated on the order. However, if it is installed incorrectly or is misused, certain application dangers can occur. Installation, wiring and maintenance of the unit must only be done by trained, skilled personnel who are authorized to do so by the plant operator. This skilled staff must have read and understood these instructions and must follow them to the letter. The plant operator must make sure that the measurement system has been correctly wired to the connection schematics.

Electrical temperature sensors such as RTD's produce low-level signals proportional to their sensed temperature. The temperature transmitter converts the low-level sensor signal to a standard 4 to 20 mA DC signal that is relatively insensitive to lead length and electrical noise. This current signal is then transmitted to the control room via two wires.

The transmitter electronics module is permanently sealed within the housing, resisting moisture and corrosive damage. Verify that the operating atmosphere of the transmitter is consistent with the appropriate hazardous locations certifications.



Warning!

Electrical shock could cause death or serious injury. If the sensor is installed in a high voltage environment and a fault or installation error occurs, high voltage may be present on the transmitter leads and terminals.

Temperature Effects

The transmitter will operate within specifications for ambient temperatures between -40 and 185 °F (-40 and 85 °C). Heat from the process is transferred from the thermowell to the transmitter housing. If the expected process temperature is near or beyond specification limits, consider the use of additional thermowell lagging, and extension nipple, or a remote mounting configuration to isolate the transmitter from the process.

1.3 Operational safety

The measuring device complies with the general safety requirements in accordance with IEC61010, the EMC requirements of IEC61326 and NAMUR recommendation NE21 and NE43.

Technical advancement

The manufacturer reserves the right to modify technical data without prior notice. Your distributor can supply you with current information and updates to these Operating Instructions.

1.4 Returns

Please follow the Return Authorization Policy.

1.5 Safety pictograms and symbols

Safe and reliable operation of this unit can only be guaranteed if the safety notes and warnings in these operating instructions are followed. The safety notes in these instructions are highlighted using the following symbols.



Note!

This icon indicates activities and actions that, if not followed correctly, could have an indirect influence on the unit operation or could lead to an unforeseen unit reaction.



Caution!

This icon indicates activities and actions that, if not followed correctly, could lead to faulty device operation or even damage to the unit.



Warning!

This icon indicates activities and actions that, if not followed correctly, could lead to personal injury, a safety risk or even total damage to the unit.



Explosion protected, type examined operating equipment!

If one of these icons is on the device's nameplate, the device can be used in hazardous areas.



Hazardous area!

This symbol identifies the hazardous area in the diagrams in these Operating Instructions.

– Devices that are used in hazardous areas or cables for such devices must have the corresponding type of protection.



Safe area (non-hazardous areas)!

This symbol identifies the non-hazardous area in the diagrams in these Operating Instructions.

– Devices in non-hazardous areas must also be certified if connection cables run through a hazardous area.

2 Identification

2.1 Unit identification

2.1.1 Legend plate

Compare the legend plates on the head transmitter with the following figures:



Fig. 1: Example: Head transmitter legend plate

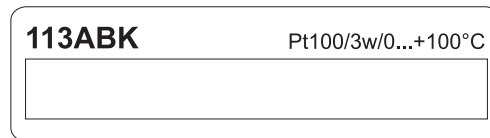



Fig. 2: Order code with configuration (example) - K = Standard model, North America region

CE Mark, declaration of conformity

The devices are designed to meet state-of-the-art safety requirements, have been tested, and left the factory in a condition in which they are safe to operate. The devices comply with the applicable standards and regulations in accordance with IEC61010 "Protection Measures for Electrical Equipment for Measurement, Control, Regulation and Laboratory Procedures" and with the EMC requirements of IEC61326. The measuring system described in these Operating Instructions thus complies with the statutory requirements of the EC Directives. The manufacturer confirms successful testing of the device by affixing to it the CE mark.

UL recognized component to UL 3111-1 

CSA GP approved

GL German Lloyd marine approval 

GL Type Approval for temperature measurements in hazardous locations on GL Classed Vessels, Marine and Offshore Installations.

2.2 Delivery contents

The delivery contents of the temperature head transmitter are as follows:

- Temperature head transmitter
- Installation screws, installation springs and E-rings
- Operating instructions



Note!

Please take note of the head transmitter accessories in chapter 8 "Accessories".

2.3 Registered trademarks

- iTEMP® and ReadWin® 2000
are registered trademarks of Endress+Hauser Wetzler GmbH + Co. KG, Nesselwang, Germany

3 Installation

3.1 Installation conditions

- When installing and operating the unit, please take note of the allowable ambient temperature (see chapter 10 "Technical Data").

3.1.1 Dimensions

The head transmitter dimensions can be found in chapter 10 "Technical data".

3.1.2 Installation point

- Sensor connection head to DIN 43 729 Form B
- Field housing

3.1.3 Installation angle

There are no limits as to the angle of installation.

3.2 Installation

3.2.1 Typical European installation

For installation, proceed as follows:

Installing in a sensor connection head to DIN 43 729 Form B (see Fig. 3)

- Feed the sensor inset cables (Pos. 5) through the central hole in the head transmitter (Pos. 4).
- Place the installation springs (Pos. 3) onto the screws (Pos. 2).
- Feed the installation screws (Pos. 2) through the holes in the head transmitter and the holes in the sensor inset (Pos. 5). Fix both screws using the E-rings (Pos. 6).
- Position the head transmitter in the connection head in such a way that the current output terminals (terminal 1 and 2) are towards the cable entry gland (Pos. 7).
- Fix the head transmitter (Pos. 4) and sensor inset (Pos. 5) into the connection head.

Installation in a field housing (see Fig. 4)

- Feed the installation screws (Pos. 2) with installation springs (Pos. 3) through the holes in the head transmitter (Pos. 4). Fix these using the E-rings (Pos. 5).
- Screw the head transmitter into the field housing using a screwdriver.



Caution!

In order to avoid damaging the head transmitter, do not over-tighten the installation screws.

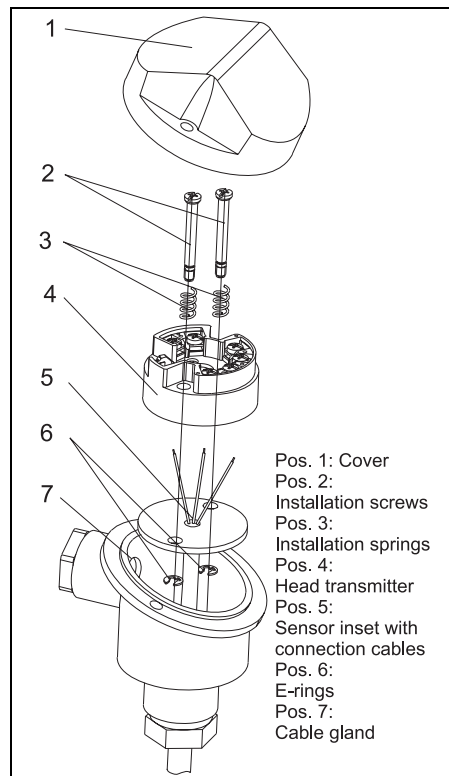

Fig. 3: Installation of head transmitter into a Form B sensor connection head.

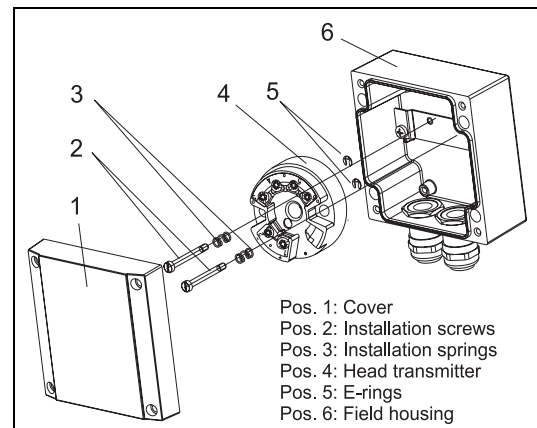

Fig. 4: Installation of head transmitter into field housing.

3.2.2 Typical North American installation

Industrial thermocouple or RTD assembly with head transmitter (see Fig. 5)

- Attach the thermowell (Pos. 1) to the pipe or process container wall. Install and tighten thermowells before applying process pressure.
- Attach necessary extension nipples and adapters (Pos. 3) to the thermowell. Seal the nipple and adapter threads with silicone tape.
- Install drain seals if required for severe environments or to satisfy code requirements.
- Feed the installation screws (Pos. 6) through the holes in the head transmitter (Pos. 7).
- Position the head transmitter assembly in the transmitter housing (Pos. 4) in such a way that the current output terminals (terminal 1 and 2) are towards the conduit.
- Screw the head transmitter assembly (Pos. 5) into the transmitter housing (Pos. 4) using a screwdriver. Max. torque $\frac{3}{4}$ pound-feet (1 Nm).
- Feed the sensor inset cables through the conduit of the transmitter housing and the central hole in the head transmitter.
- Attach the transmitter housing (Pos. 4) with built-in head transmitter assembly to the nipples and adapters (Pos. 3). Seal adapter threads with silicone tape.



Caution!

In order to avoid damaging the head transmitter, do not over-tighten the installation screws.



Caution!

Pull the field wiring leads through the conduit into the transmitter housing. Attach the sensor and power leads to the head transmitter. Avoid contact with other terminals.



Caution!

Install and tighten the transmitter housing cover. Enclosure covers must be fully engaged to meet explosion-proof requirements.

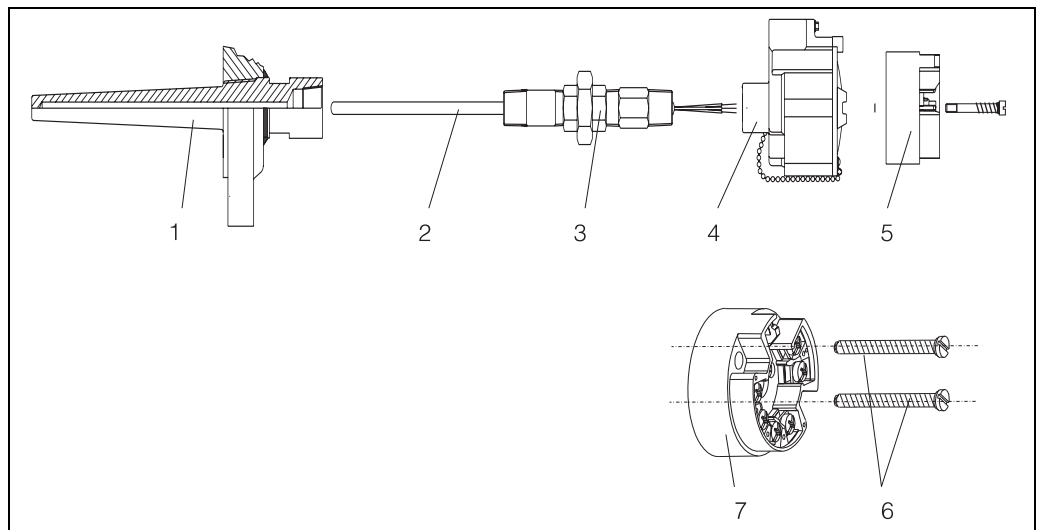

Fig. 5: Installing the head transmitter - Head transmitter assembly

Pos. 1: Thermowell

Pos. 2: Measuring inset

Pos. 3: Extension neck

Pos. 4: Transmitter housing

Pos. 5: Head transmitter assembly

Pos. 6: Installation screws

Pos. 7: Head transmitter

4 Wiring

4.1 Overview

Terminal layout

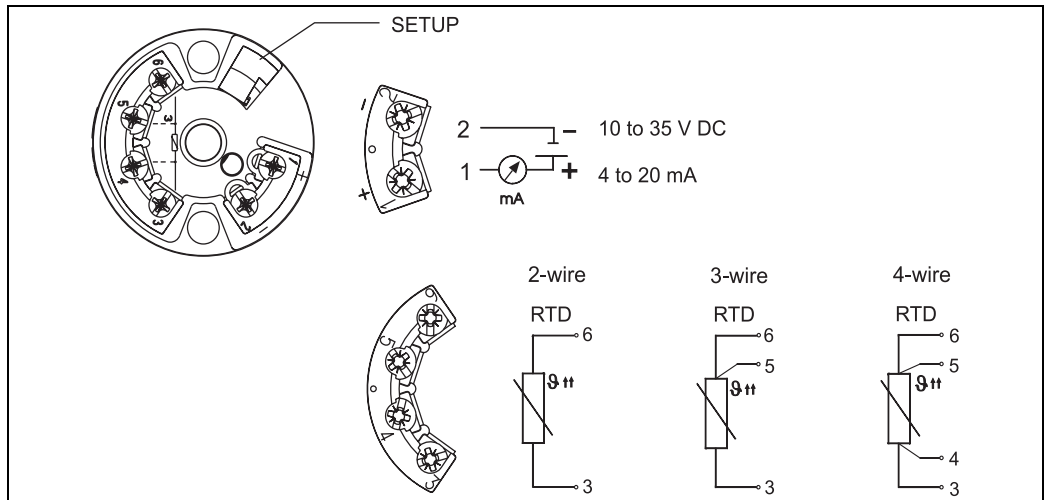

Fig. 6: Head transmitter wiring

4.2 Measurement unit connection



Caution!

- Switch off power supply before opening the housing cover. Do not install or connect the unit to power supply. If this is not followed parts of the electronic circuit will be damaged.
- If the device has not been grounded as a result of the housing being installed, we recommend grounding it via one of the ground screws.

■ Sensors:

Connect the sensor cables to the respective head transmitter terminals (Terminals 3 to 6) by following the wiring diagram (see Fig. 6).

■ Output signal and power supply:

Open the cable gland on the sensor head or field housing. Feed the cable through the opening in the cable gland and then connect the cable cores to terminals 1 and 2 according to the wiring diagram (see Fig. 6).

■ PC configuration (SETUP socket):

Open the flap on the SETUP socket (see Fig. 6) and connect the SETUP connection cable.

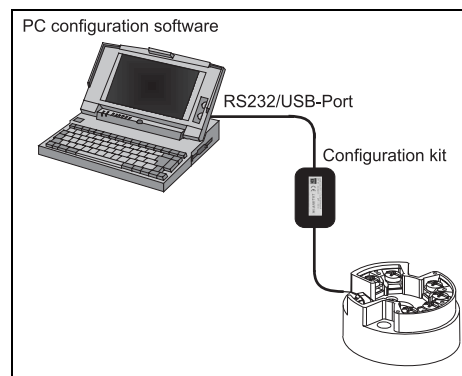

Fig. 7: Connection to PC for configuration

**Note!**

The screws on the terminals must be screwed in tightly. Head transmitter configuration during measurement operation is possible. There is no need to disconnect cables!

4.3 Potential grounding

**Note!**

Please take note of the following when remotely installing the head transmitter in a field housing. The shield on the output (output signal 4 to 20 mA) must be at the same potential as the shield at the sensor connection. For an effective shielding the cable shield must be solidly connected to the field housing. This can be achieved by connecting the cable shield to the special EMC cable gland.

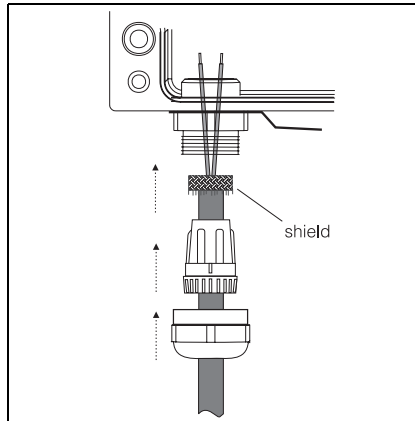

Fig. 8: Shielding on remote installation

Open the field housing cable gland and connect the shield of the output and sensor connection according to the figure opposite (see Fig. 8). In plants with strong EMC problems shielding of all cables with a low ohm connection to the transmitter housing is recommended.

4.4 Ground the Transmitter

The transmitter will operate with the current signal loop either floating or grounded. However, the extra noise in floating systems affects many types of readout devices. If the signal appears noisy or erratic, grounding the current signal loop at a single point may solve the problem. The best place to ground the loop is at the negative terminal of the power supply. Do not ground the current signal loop at more than one point.

5 Operation

5.1 Communication

The head transmitter must be set up using a PC and configuration set. The following points must be taken into account if trouble-free setup is to be achieved:

- Configuration software installation
More details and download see:
www.readwin2000.com
- Connect the head transmitter to the PC using the connection cable from the configuration set.

5.1.1 Configuration software installation (ReadWin® 2000)

System conditions	<ul style="list-style-type: none"> – IBM PC or compatible computer (min. Pentium 166 MHz) – Windows 95/98/ME/NT4.0/2000/XP – 64 MB RAM – Mouse – CD-ROM drive – Screen resolution 800 x 600 Pixel – free serial interface
Recommended minimum configuration	<ul style="list-style-type: none"> – Pentium 400 MHz – 128 MB main RAM – 120 MB free hard drive memory – Screen resolution 1024 x 768 Pixel
Installation start	<p>Start Windows®:</p> <ol style="list-style-type: none"> 1. Place installations-CD in the respective drive 2. Generally, the 'Autorun'-file starts. If not, start "Setup.exe" and follow the installation instructions 3. If required the help/operating manual can be printed out once the software has been successfully installed.

5.1.2 Connecting the head transmitter to the PC using the configuration kit connection cable



Caution!

Please make sure that when setting up the device by means of the configuration kit (see chap. accessories) that the supply to the programming device (=PC and interface cable) is galvanically isolated from the transmitter power supply, e.g.:

- By using a battery operated PC (e.g. laptop) when the transmitter is already installed on plant
 - By setting up without any wiring of the power supply to the transmitter
1. Connect the SETUP connector of the interface connecting cable to the SETUP socket in the head transmitter (see 'Fig. 7' in Chapter 4.2).
 2. Connect the RS232C connector to a free serial interface socket or the USB connector to a free USB port on the PC. In order to achieve optimum connection, tighten the RS232C connector screws to the PC.



Note!

When the PC serial interface cable is connected (see chapter 'Accessories'), the technical specifications (e.g. measured error) are not observed. For this reason, during operation disconnect the connection via the serial interface cable between the head transmitter and PC.

6 Commissioning

6.1 Installation and function check

Installation check

Monitor all connections making sure they are tight. In order to guarantee fault-free operation, the terminal screws must be screwed tightly onto the connection cables.

Function check

Measuring the analog 4 to 20 mA output signal or following failure signals:

Measurement range undercut	linear fall to 3.8 mA
Measurement range excess	linear rise to 20.5 mA
Sensor break; sensor short circuit	≤ 3.6 mA or ≥ 21.0 mA

6.2 Switch on the device

Once the power supply has been connected, the head transmitter is operational.

6.3 Configuration

6.3.1 Setting up using the PC configuration software

The operating and readout software is an universally applicable service and configuration software. The operating software offers the user the following possibilities:

- Set-up device functions
- Measured value visualization
- Device parameter data storage
- Measuring point documentation

The head transmitter left the factory with a default parameter configuration. If no customer specific configuration was mentioned on the order then the default parameter configuration is constructed as follows:

Sensor	Pt100 (RTD)
Connection mode	3-wire
Measuring range and units	0 to +100 °C



Note!

If a change has been made to the measurement point then, head transmitter can be re-configured. In order to re-configure the parameters follow these instructions:

- Install the configuration software and make connection to the PC (see Chap. 5, 'Operation').
- For detailed operating instructions for the PC configuration software please read the online documentation (**BA137R/09/ae**) contained in the PC operation and readout software (see folder '**Doc**').

This software can be downloaded free of charge from the Internet at the following address:
www.readwin2000.com

6.3.2 Description of device functions

All parameters that can be read out and set-up for the configuration of the temperature transmitter are listed and described in the following table. Also the menu structure in the PC configuration software is shown in the following table.

Configurable parameters (Default settings in bold)				
Standard settings				
Sensor type	Sensor type Pt100 (TMT180-**1) Pt100 (TMT180-**2) Polynom RTD (TMT180-**1) Polynom RTD (TMT180-**2)	Range start value -328 °F (-200 °C) -58 °F (-50 °C) -328 °F (-200 °C) -58 °F (-50 °C)	Range end value 1202 °F (650 °C) 482 °F (250 °C) 1202 °F (650 °C) 482 °F (250 °C)	min. range 18 °F (10 °C) 18 °F (10 °C) 18 °F (10 °C) 18 °F (10 °C)
Connection mode	Input of RTD connection mode. Input: <ul style="list-style-type: none"> ■ 2-wire ■ 3-wire ■ 4-wire 			
Unit	Input for unit Input: °C or °F			
Measurement range start value	Input of 4 mA value. Input: Limitation values see ' Sensor type ' 0 °C			
Measurement range end value	Input of 20 mA value. Input: Limitation values see ' Sensor type ' 100 °C			
Coefficient X0 to X4	On sensor type polynom RTD, see description ' Customer specific linearization '			
Expanded settings				
Cable resistance	Input of cable resistance compensation on a 2-wire RTD connection. Input: 0.00 to 20.00 Ω  Note! Function is only active when a 2-wire RTD connection has been selected, see ' Sensor type '.			
Fault condition	Input of the output signal on sensor rupture or short circuit. Input: <ul style="list-style-type: none"> ■ max (≥ 21.5 mA) ■ min (≤ 3.6 mA) 			
Output	Input of the standard (4 to 20 mA) or inverse (20 to 4 mA) current output signal. Input: <ul style="list-style-type: none"> ■ 4 to 20 mA ■ 20 to 4 mA 			
Filter	Selection of the digital filter 1. order (filter time constant). Input: 0 to 8 s			
Offset	Input of the zero point correction (offset). Input: -10.00 to 10.00 °C (-18.00 to 18.00 °F) 0.00 °C			
Measuring point ident	Measuring point description Input: 8 characters			

Configurable parameters (Default settings in bold)	
Service functions	
Output simulation	Activate simulation mode. Input: <ul style="list-style-type: none"> ■ OFF ■ ON Input of the simulation value (current). Input: 3.8 to 20.5 mA

Customer-specific linearization

Customer-specific linearization and sensor matching are activated after the **POLYNOM RTD** sensor type is selected. Please find detailed information about linearization in the PC configuration software.

7 Maintenance

The temperature transmitter has no moving parts and requires minimal scheduled maintenance.

Sensor Checkout

To determine whether the sensor is at fault, replace it with another sensor or connect a test sensor locally at the transmitter to test remote sensor wiring. Select any standard, off-the-shelf sensor for use with a temperature head transmitter, or consult the factory for a replacement special sensor or transmitter combination.

8 Accessories

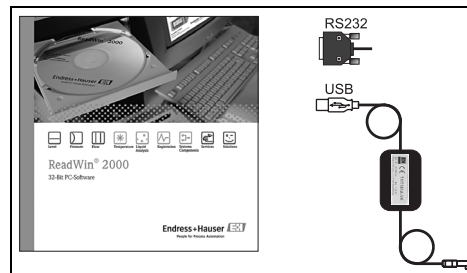

Configuration set for PC SETUP (SETUP program and PC serial interface cable:
 → Order No.: TMT180A-VM (TTL/RS 232C)
 → Order No.: TXU10-AB (TTL/USB).

ReadWin® 2000, DIN rail clip (SONDTT-AF) according to IEC 60715 for E+H temperature head transmitters, Field housing TAF 10 suitable for E+H temperature head transmitters.

PC SETUP program can be downloaded free of charge from the internet from the following address:

www.readwin2000.com

Please contact your supplier when ordering (e.g. spare parts)!

9 Trouble-shooting

9.1 Trouble-shooting instructions

If faults occur after commissioning or during measurement always start any fault finding sequence using the following checklists. The user is guided to the possible fault cause and its removal by question and answer.

9.2 Application errors without messages

9.2.1 General application errors

Error	Cause	Action/cure
No communication	2 wire connection incorrect	Re-connect correctly (see connection diagram)
	No power supply on the 2-wire connection	Check the current loop
	Power supply too low (< 10 V)	Check power supply
	Defective interface cable	Check interface cable
	Defective interface	Check PC interface
	Defective device	Replace device

9.2.2 Application errors for RTD connection (Pt100)

Error	Cause	Action/cure
Fault current (≤ 3.6 mA or ≥ 21 mA)	Defective sensor	Check sensor
	Incorrect connection of RTD	Connect cables correctly to terminal schematic
	Incorrect connection of the 2-wire cable	Connect cables correctly to terminal schematic (polarity)
	No power supply on the 2-wire connection	Check current loop; the supply should be > 10 V
	Incorrect transmitter programming (number of wires)	Change device function 'Connection mode' (see chap. 'Commissioning')
	Defective device	Replace device

Error	Cause	Action/cure
Measured value incorrect/ inaccurate	Faulty sensor installation	Install sensor correctly
	Heat conducted by sensor	Take note of sensor installation point
	Transmitter setup faulty (number of wires)	Change device function 'Connection mode'
	Transmitter setup faulty (scale)	Change scale
	Incorrect RTD setup	Change device function 'Sensor type'
	Sensor connection (2-wire)	Check sensor connection
	Sensor cable resistance (2-wire) not compensated	Compensate cable resistance
	Offset incorrectly set	Check offset

9.3 Spare parts

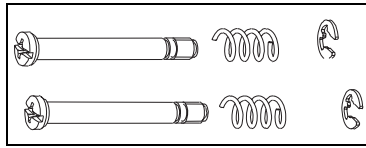

Head transmitter installation set:

- For European Style installation: (8 screws, 8 springs, 8 E-rings)
 - For U.S. Style installation: (8 machine screws M4x20)
- Order No.: TMT180A-KA

9.4 Returns

Please follow the Return Authorization Policy.

9.5 Disposal

Due to its construction, the head transmitter cannot be repaired. When disposing of the head transmitter please take note of the local disposal regulations.

9.6 Software history

Software version / date	Changes to software	Changes to documentation
1.00.xx / 10.2001	Original firmware compatible with: ■ ReadWin® 2000 1.2.2 and higher	
1.01.xx / 04.2003	Original firmware compatible with: ■ ReadWin® 2000 1.12.0.0 and higher	-

10 Technical Data

10.0.1 Function and system design

Measuring principle Electronic monitoring and conversion of input signals in industrial temperature measurement.

Measuring system The temperature head transmitter is a two wire transmitter with an analog output. It has measurement input for resistance thermometers (RTD) in 2-, 3- or 4-wire connection. Setting up of the unit is done using the configuration set for PC.

10.0.2 Input

Measured variable Temperature (temperature linear transmission behavior)

Measuring range The transmitter monitors different measuring ranges depending on the sensor connection and input signals.

Type of input

Input	Designation	Measuring range limits	Min. span
Resistance thermometer (RTD) to IEC 751 ($\alpha = 0.00385$)	Pt100 (TMT180-**1)	-328 to 1202 °F (-200 to 650 °C)	18 °F (10 °C)
	Pt100 (TMT180-**2)	-58 to 482 °F (-50 to 250 °C)	18 °F (10 °C)
<ul style="list-style-type: none"> ■ Connection type: 2-, 3- or 4-wire connection ■ Software compensation of cable resistance possible in the 2 wire system (0 to 20 Ω) ■ Sensor cable resistance max. 11 Ω per cable in the 3 and 4 wire system ■ Sensor current: ≤ 0.6 mA 			

10.0.3 Output

Output signal Analog 4 to 20 mA, 20 to 4 mA

Breakdown information **Breakdown information to NAMUR NE 43**
Breakdown information is created when the measuring information is invalid or not present anymore and gives a complete listing of all errors occurring in the measuring system.

		Signal (mA)
Under ranging	Standard	3.8
Over ranging	Standard	20.5
Sensor break; sensor short circuit low	To NAMUR NE 43	≤ 3.6
Sensor break; sensor short circuit high	To NAMUR NE 43	≥ 21.0

Source impedance max. $(V_{\text{Power supply}} - 10 \text{ V}) / 0.022 \text{ A}$ (current output)
 e.g. $(24 \text{ V} - 10 \text{ V}) / 0.022 \text{ A} = 636.4 \Omega$

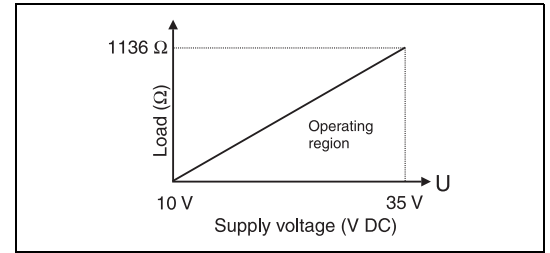

Transmission behavior Temperature linear

Filter 1st order digital filter: 0 to 8 s

Input current required $\leq 3.5 \text{ mA}$

Current limit $\leq 23 \text{ mA}$

Switch on delay 4 s (during power up $I_a \leq 3.8 \text{ mA}$)

Response time 1 s

10.0.4 Power supply

Electrical connection See 'Terminal layout' in Chapter 'Wiring'.

Supply voltage $U_b = 10 \text{ to } 35 \text{ V}$, polarity protected

Residual ripple Allowable ripple $U_{ss} \leq 3 \text{ V}$ at $U_b \geq 13 \text{ V}$, $f_{\text{max.}} = 1 \text{ kHz}$

10.0.5 Performance characteristics

Reference operating conditions Calibration temperature: $77 \text{ °F} \pm 9 \text{ °F}$ ($+25 \text{ °C} \pm 5 \text{ °C}$)

Maximum measured error

	Type	Measurement accuracy ¹⁾
Resistance thermometer RTD	Pt100 -328 to 1202 °F (-200 to 650 °C)	0.36 °F (0.2 °C) or 0.08%
	Pt100 -58 to 482 °F (-50 to 250 °C)	0.18 °F (0.1 °C) or 0.08%

1) % is related to the adjusted measurement range. The value to be applied is the greater.

Influence of supply voltage ■ $\leq \pm 0.01\%/V$ deviation from 24 V
 Percentages refer to the full scale value.

Influence of ambient temperature (Temperature drift) ■ Resistance thermometer Pt100:
 $T_d = \pm(8.3 \text{ ppm}/\text{°F} * (\text{range end value} + 328) + 27.8 \text{ ppm}/\text{°F} * \text{preset meas. range}) * \Delta \vartheta$
 $\Delta \vartheta =$ Deviation of the ambient temperature according to the reference condition ($73.4 \text{ °F} \pm 9 \text{ °F}$).

Influence of load ■ ± 0.02%/100 Ω
 Percentages refer to the full scale value

Long-term stability ■ ≤ 0.18 °F/year (≤ 0.1 °C/year) or ≤ 0.05%/year
 Values under reference operating conditions. % refer to the set span. The highest value is valid.

10.0.6 Installation conditions

Installation conditions ■ Installation angle: no limit
 ■ Installation area: connection head accord. to DIN 43 729 Form B; field housing TAF 10

10.0.7 Environmental conditions

Ambient temperature limits -40 to 185 °F (-40 to +85 °C)

Storage temperature -40 to 212 °F (-40 to +100 °C)

Climate class as per IEC 60654-1, class C

Condensation allowed

Degree of protection IP 00, NEMA 4 (IP 66) installed in field housing TAF 10

Shock and vibration resistance 4g / 2 to 150 Hz as per IEC 60 068-2-6

Electromagnetic compatibility **CE Electromagnetic Compatibility Compliance**
 (EMC) The device meets all requirements listed under IEC 61326 Amendment 1, 1998
 This recommendation is a uniform and practical way of determining whether the devices used in laboratory and process control are immune to interference with an objective to increase its functional safety.

Discharge of static electricity	IEC 61000-4-2	6 kV cont., 8 kV air	
Electromagnetic fields	IEC 61000-4-3	80 to 2000 Hz	10 V/m
Burst (signal)	IEC 61000-4-4	1 kV 2 kV (B) ¹⁾	
Transient voltage	IEC 61000-4-5	1 kV unsym. / 0.5 kV sym.	
HF coupling	IEC 61000-4-6	0.15 to 80 MHz	10 V

1) self recovery

10.0.8 Mechanical construction

Design, dimensions

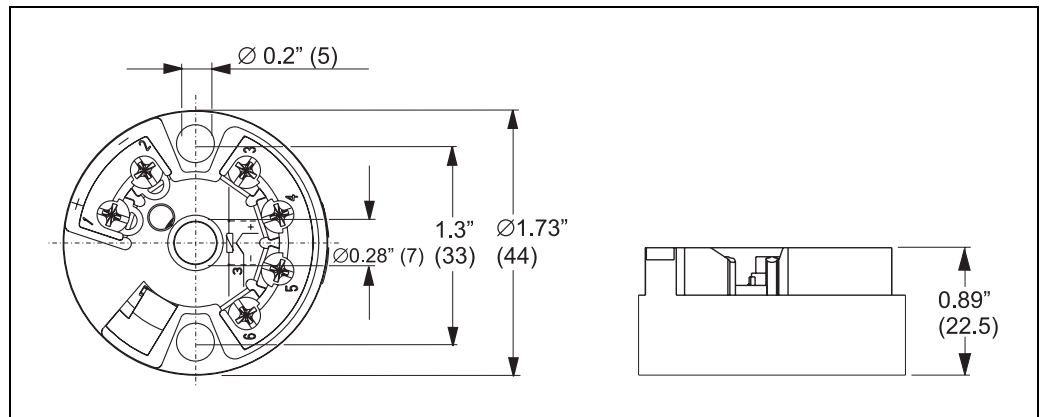

Fig. 9: Dimensions of the head transmitter in inches (mm)

Weight

approx. 1.4 oz (40 g)

Material

- Housing: PC
- Potting: PUR

Terminals

- Cable up to max. 16 AWG (secure screws)
- or 16 AWG with wire end ferrules

10.0.9 Human interface

Display elements

No display elements are present directly on the temperature transmitter. The measured value display can be called up using the PC configuration software ReadWin® 2000.

Operating elements

No operating elements are present directly on the transmitter to prevent from manipulation. The device parameters of the head transmitter are configured using the PC operating software ReadWin® 2000.

Remote operation

Configuration set

Configuration kit TMT180A-VM or TXU10, configurable on PC software program ReadWin® 2000. Starting from version R2.00.00 of the TMT180A the temperature head transmitter is configurable without voltage supply.

Interface

PC interface connection cable TTL-/RS232 or USB with plug.

Configurable parameters

Sensor type and connection type Pt100, engineering units (°C/°F), measurement range, cable resistance compensation on 2 wire connection, fault conditioning, output signal (4 to 20 mA/20 to 4 mA), offset, measurement point identification (8 characters), output simulation

10.0.10 Certificates and approvals

CE-Mark	The measurement system fulfils the requirements demanded by the EU regulations. Endress+Hauser acknowledges successful unit testing by adding the CE mark.
UL	Recognized component to UL 3111-1
GL	Ship building approval (Germanischer Lloyd)
CSA GP	CSA General Purpose
Other standards and guidelines	<ul style="list-style-type: none"> ■ IEC 60529: Degrees of protection by housing (IP-Code) ■ IEC 61010: Safety requirements for electrical measurement, control and laboratory instrumentation ■ IEC 61326: Electromagnetic compatibility (EMC requirements) ■ NAMUR Standardization association for measurement and control in chemical and pharmaceutical industries. (www.namur.de) ■ NEMA Standardization association for the electrical industry

Index

B

Brief overview 2

C

CE mark 6

Configuration software installation

 Installation start 12

 Recommended minimum configuration 12

 System conditions 12

CSA GP approval 6

Customer-specific linearization 15

D

Default parameter configuration 13

Device functions

 Expanded settings 14

 Service functions 14

 standard settings 14

Dimensions 7

F

Fault checklists 16

Function check

 Measurement range excess 13

 Measurement range undercut 13

 Sensor short circuit 13

Function group 14

G

GL approval 6

I

Installation angle 7

Installation check 13

Installation point

 Field housing 7

 Form B Sensor connection head 7

Installation screws 8–9

Installation springs 8

L

Legend plate 6

M

Measurement unit connection

 Output signal and power supply 10

 PC setup socket 10

 Sensors 10

O

Online documentation 13

R

Returns 17

S

Safety message 2

Sensor Checkout 15

T

Technical advancement 5

Terminal layout 10

Thermowell 9

U

UL recognized component 6

United States

Endress+Hauser, Inc.
2350 Endress Place
Greenwood, IN 46143
Tel: 317-535-7138
Sales: 888-ENDRESS
Service: 800-642-8737
FAX: 317-535-8498
inquiry@us.endress.com
www.us.endress.com

Canada

Endress+Hauser Canada
1075 Sutton Drive
Burlington, ON L7L 5Z8
Tel: 905-681-9292
800-668-3199
FAX: 905-681-9444
www.ca.endress.com

Mexico

Endress+Hauser (Mexico) S.A. de C.V.
Av. Gustavo Baz No. 43
Fracc. Bosques de Echegaray
Naucalpan de Juárez, C.P. 53310,
Estado de Mexico
Mexico
Tel: (52) 55 5371 1110
FAX: (52) 55 5371 1128
E-mail: eh.mexico@mx.endress.com

Endress+Hauser 

People for Process Automation