



Level



Pressure



Flow



Temperature



Liquid
Analysis



Registration



Systems
Components



Services



Solutions

Brief Operating Instructions

Oxymax W COS41

Dissolved oxygen sensor



These instructions are Brief Operating Instructions.
For detailed information, please read the Operating Instructions and the special instructions on the supplied CD-ROM.

The complete device documentation comprises:

- these Brief Operating Instructions
- the Operating Instructions on the supplied CD-ROM
- if necessary, certificates and calibration protocols (acc. to the version).

Table of contents

| | |
|---|-----------|
| 1 Safety instructions | 2 |
| 1.1 Designated use | 2 |
| 1.2 Installation, commissioning and operation | 2 |
| 1.3 Operational safety | 3 |
| 2 Installation | 3 |
| 2.1 Installation conditions | 3 |
| 2.2 Installation instructions | 4 |
| 2.3 Installation examples | 5 |
| 2.4 Post installation check | 8 |
| 3 Wiring | 9 |
| 3.1 Direct connection to the transmitter | 9 |
| 3.2 Connection via junction box | 10 |
| 4 Commissioning | 11 |
| 4.1 Function check | 11 |
| 4.2 Polarization | 11 |
| 4.3 Calibration | 12 |

1 Safety instructions

1.1 Designated use

The oxygen sensor is suitable for continuous measurement of dissolved oxygen in water.

Typical applications are:

- Measuring, monitoring and regulating the oxygen content in activated sludge basins.
- Monitoring the oxygen content in the sewage treatment plant outlet.
- Monitoring, measuring and regulating the oxygen content in public waters and fish farming water.
- Monitoring of oxygen enrichment in drinking water.

Any other use than the one described here compromises the safety of persons and the entire measuring system and is, therefore, not permitted.

The manufacturer is not liable for damage caused by improper or non-designated use.

1.2 Installation, commissioning and operation

- The device/measuring system may only be installed, connected, operated and maintained by trained technical personnel (e.g. certified electrician). The technical personnel must strictly adhere to the Operating Instructions, prevailing standards, legal regulations and certificates (depending on application).
- If the Brief Operating Instructions do not provide sufficient information, you must read the Operating Instructions. There, you can find detailed information on the device.

- The operator may only perform modifications and repairs of the device/measuring system that are explicitly permitted in the Operating Instructions.
- Do not operate damaged products and secure them against unintentional commissioning. Mark the damaged product as being defective.
- If faults can not be rectified, the products must be taken out of service and secured against unintentional commissioning.

1.3 Operational safety

The sensor has been designed and tested according to the state of the art and left the factory in perfect functioning order.

Relevant regulations and European standards have been met.

As the user, you are responsible for complying with the following safety conditions:

- Installation instructions
- Local prevailing standards and regulations.



Caution!

Pay attention to the technical data on the name plate!

2 Installation

2.1 Installation conditions

2.1.1 Orientation

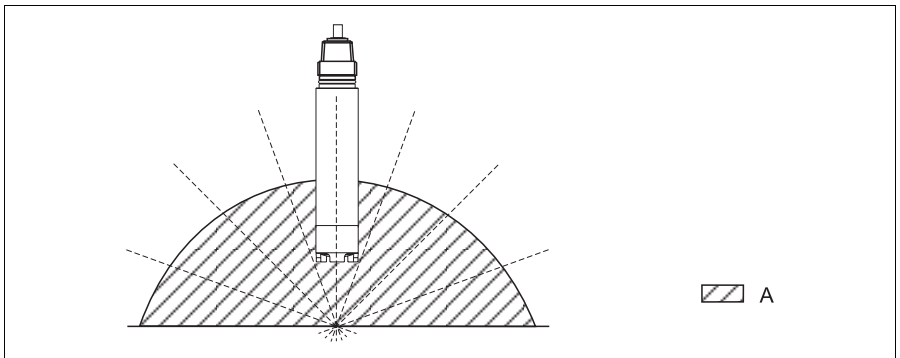

Fig. 1: Angle of installation

A Recommended angle of installation: 0 ... 180 °

Other angles are not permitted. Do **not** install the sensor overhead.

2.1.2 Mounting location

- Select the installation location so that there is easy access for later calibration.
- Make sure that upright posts and assemblies are secured safely and vibration-free.
- For immersed operation in an activated sludge basin, select an installation location which produces a typical oxygen concentration.

2.2 Installation instructions

2.2.1 Installing a measuring point



Note!

For immersed operation, install the individual modules away from the basin on a solid base. Only carry out the final installation at the intended installation location.

For a complete installation of a measuring point, proceed as follows:

1. Install a retractable or a flow assembly (if used) into the process.
2. Connect the water supply to the rinse connections (if you use an assembly with cleaning function).
3. Install and connect the oxygen sensor.
4. Install an immersion or an suspension assembly (if used) into the process.



Caution!

- For immersed operation, the sensor must be installed in an immersion assembly (e.g. CYA611). **Do not install the sensor suspended from the cable.**
- Screw the sensor into the assembly so that the cable is not twisted.
- Avoid exerting excessive tensile force on the cable (e.g. from jerky pulling).
- Select the installation location so that there is easy access for later calibration.



Warning!

When using metallic assemblies and installation equipment, comply with national grounding regulations.

2.3 Installation examples

2.3.1 Immersion operation

Universal assembly holder and chain assembly

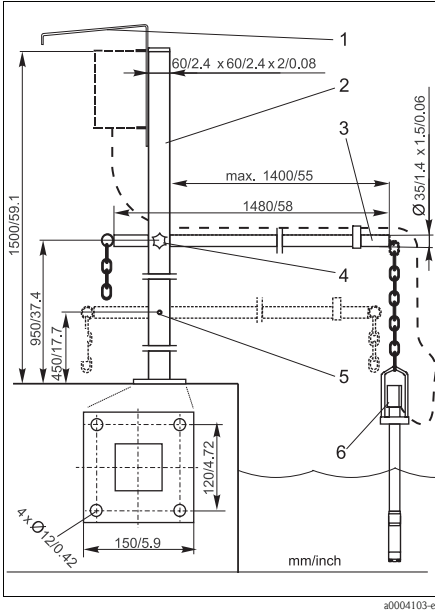

Fig. 2: CYH101 with immersible pendulum assembly

- 1 Weather protection cover
- 2 Upright post, square pipe SS AISI 304
- 3 Transverse pipe SS AISI 304
- 4 Star handle
- 5 Second fixing possibility for transverse pipe
- 6 Immersion assembly CYA 611

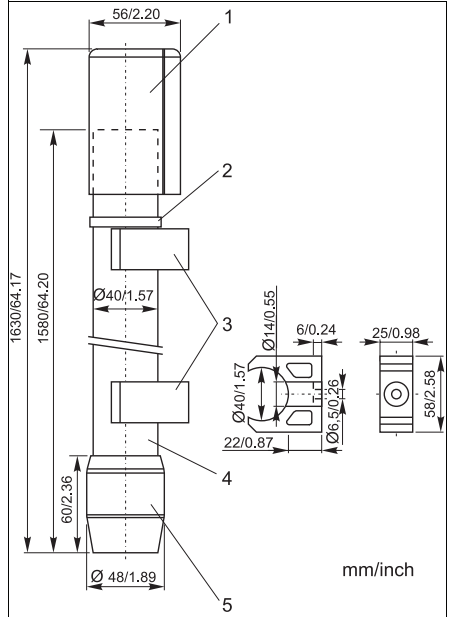
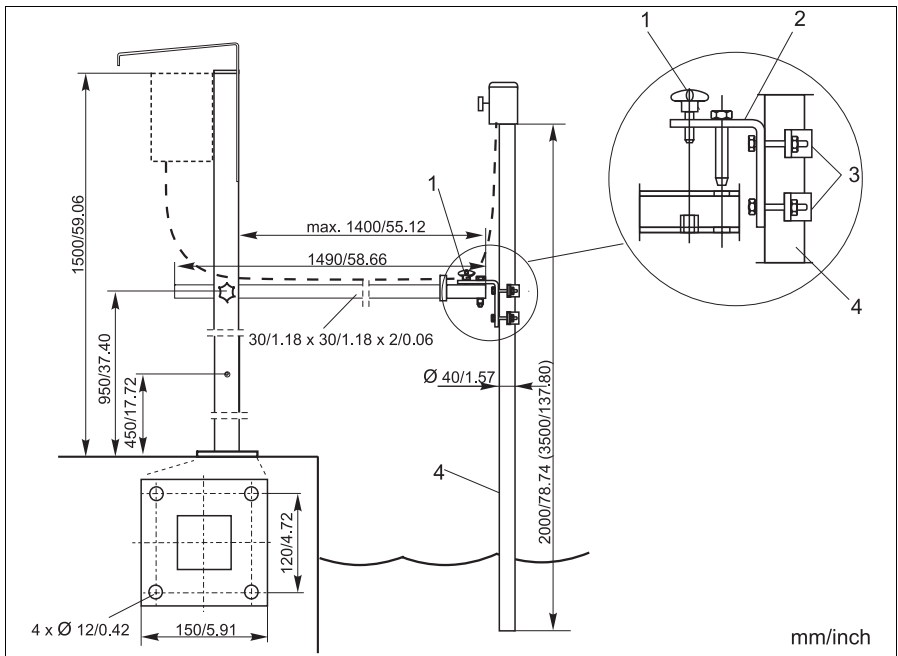

Fig. 3: Immersion assembly CYA 611

- 1 Protection cap
- 2 Worm drive hose clip
- 3 Pipe clips (detailed drawing in right half)
- 4 PVC pipe
- 5 Threaded coupling

Universal assembly holder and fixed immersion assembly



a0004105-en

Fig. 4: Universal suspension assembly holder CYH101 with immersion assembly CYY105

- 1 Star handle
- 2 Pipe holder
- 3 Fixing bracket
- 4 Immersion assembly (= immersion tube)

Basin rim mounting with immersion tube

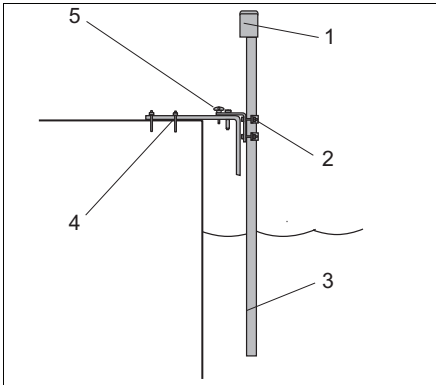

Fig. 5: Horizontal basin rim mounting

- 1 Protection cover for cable entry
- 2 Assembly holder
- 3 Immersion assembly SS 1.4301 (AISI 304)

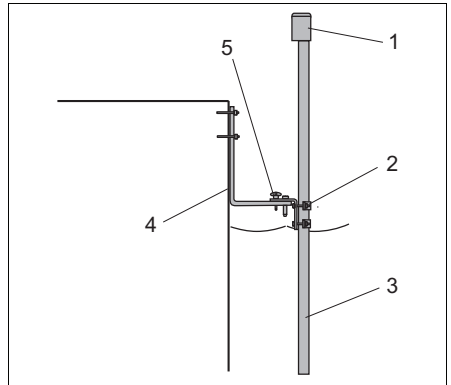

Fig. 6: Vertical basin rim mounting

- 4 Basin rim mounting
- 5 Star handle

Floating body

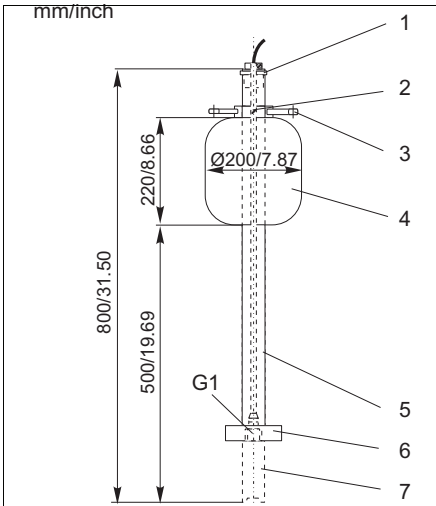

Fig. 7: Floating body

- 1 Cable route with strain relief and rain protection
- 2 Mounting ring for ropes and chains with locking screw
- 3 Lugs Ø15, 3 x 120 ° for anchoring
- 4 Saltwater-resistant plastic float
- 5 Pipe 40x1, stainless steel 1.4571 (AISI 316Ti)
- 6 Shock absorber and weight
- 7 Oxygen sensor

2.3.2 Flow assembly

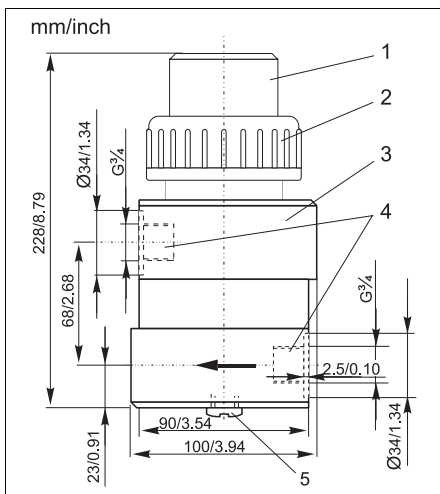

Fig. 8: Flow assembly COA250-B

- 1 Screw-in part for sensor
- 2 Screw ring
- 3 Meter body
- 4 Connection thread G $\frac{3}{4}$
- 5 Dummy plug (connection for spray head COR3)

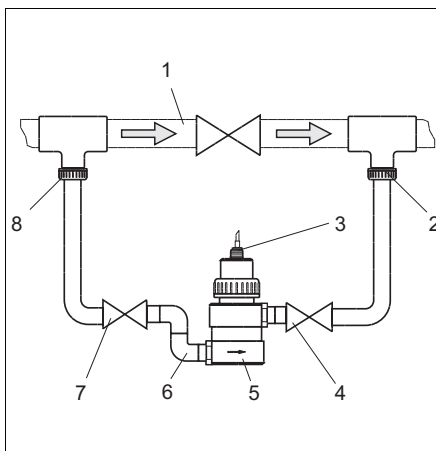

Fig. 9: Bypass installation

- 1 Main line
- 2 Medium return
- 3 Oxygen sensor
- 4, 7 Manually actuated or solenoid valves
- 5 Flow assembly COA250-B
- 6 90° pipe bracket
- 8 Medium removal

2.4 Post installation check

- Check the membrane for leak tightness und replace it if necessary.
- Sensor and cable undamaged?
- Compliance with permissible sensor installation position?
- Is the sensor installed in an assembly and is not suspended from the cable?
- Avoid moisture by rain by fitting the protective cap to the immersion assembly?

3 Wiring



Warning!

- The electrical connection must only be carried out by a certified electrician.
- Technical personnel must have read and understood the instructions in this manual and must adhere to them.
- Ensure that there is no voltage at the power cable before beginning the connection work.

3.1 Direct connection to the transmitter

The sensor is connected using a special measuring cable (→  10). The wiring diagram is contained in the Operating Instructions of the COM223/253-DX/DS transmitter.

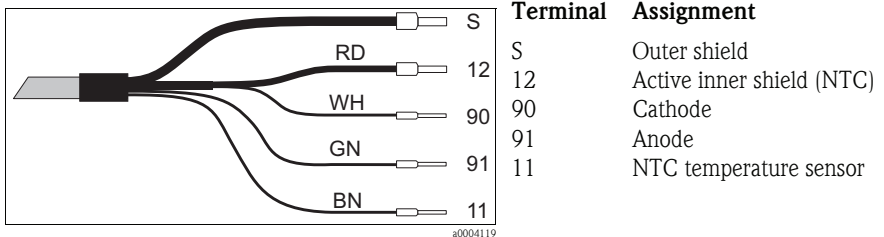

Fig. 10: Special measuring cable CYK 71



Note!

The interior white and yellow pilot wires have no function.

3.2 Connection via junction box

To lengthen the sensor connection beyond the length of the fixed cable, you require a junction box VBM. The connection is lengthened to the transmitter using the special measuring cable CYK71.

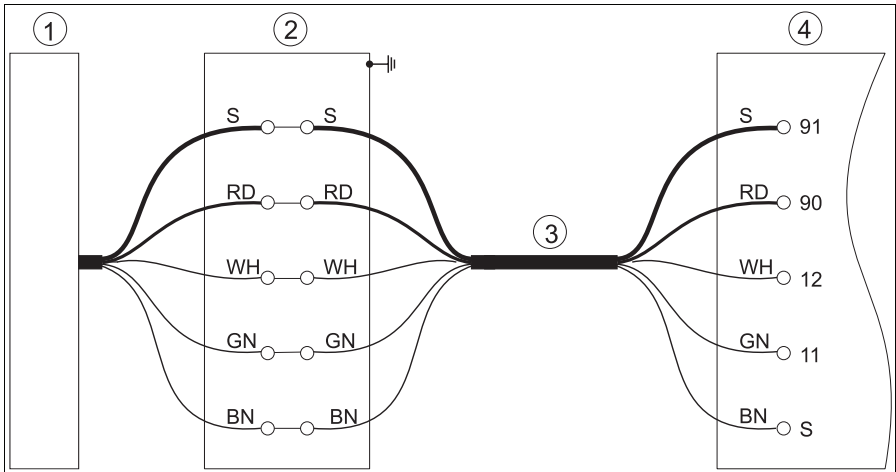

Fig. 11: Connection via junction box VBM

a0004127

- 1 Sensor
- 2 Junction box
- 3 Extension cable
- 4 Transmitter

4 Commissioning

4.1 Function check

Before first commissioning, check if:

- the sensor is correctly installed
- the electrical connection is correct.

If using an assembly with automatic cleaning, check the correct water connection at the assembly rinse connection.



Warning!

Danger of medium leaking off

Before applying compressed air to an assembly with cleaning facility, make sure the connections are correctly fitted. Otherwise, the assembly may not be insert into the process.

4.2 Polarization

The sensor was tested in the factory for perfect functionality and is supplied ready for operation.

To prepare for calibration, proceed as follows:

1. Remove the sensor protective cap.
2. Place the externally dry sensor in atmospheric air. The air should be saturated with water vapour. Therefore, install the sensor as close to the water surface as possible. When calibrating the sensor membrane, make sure the membrane remains dry. Therefore, avoid any direct contact with the water surface.
3. Connect the sensor to the transmitter and switch on the transmitter.
4. Switch-on the transmitter.
If you connect the sensor to the transmitter Liquisys M COM223/253, polarisation is automatically performed after switching on the transmitter.
5. The polarisation time takes about 1 hour.



Note!

Polarisation starts high, then drops gradually. You will recognise the end of polarisation when the display stabilises and remains practically constant.



Caution!

- When you remove the sensor from the medium, protect the sensor from strong sunlight.
- Make sure you comply with the instructions for commissioning and calibration in the Operating Instructions of the transmitter.

4.3 Calibration

Calibrate the sensor (calibration type "Air") immediately after it's polarization.

1. Remove the sensor from the medium.
2. Clean the outside of the sensor with a damp cloth. Then dry the sensor membrane e.g. by using a tissue.
3. If the sensor is removed from a closed pressure system with a process pressure greater than atmospheric pressure:
 - Open the membrane cap to equilibrate the pressure and clean the cap if necessary.
 - Replace the electrolyte filling and close the membrane cap again.
 - Wait for the polarisation time to end.
4. Then wait while the sensor adjusts to the temperature of the ambient air. This takes about 20 minutes. Check that the sensor is not in direct sunlight during this time.
5. If the measured value display on the transmitter is stable, carry out the calibration in accordance with the Operating Instructions of the transmitter.
6. Place the sensor in the medium again.



Note!

Make sure you comply with the instructions for calibration in the Operating Instructions of the transmitter.

www.endress.com/worldwide

Endress+Hauser 
People for Process Automation

