



Level



Pressure



Flow



Temperature



Liquid
Analysis



Registration



Systems
Components



Services



Solutions

Operating Instructions

Turbimax W CUS31

Turbidity sensor

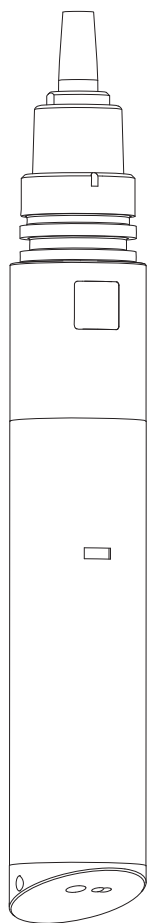

Table of contents

1	Safety instructions	4	9.5	Mechanical construction	21
1.1	Designated use	4			
1.2	Installation, commissioning and operation	4			
1.3	Operational safety	4			
1.4	Return	5			
1.5	Notes on safety icons and symbols	5			
2	Identification	6			
2.1	Product structure	6			
2.2	Scope of delivery	6			
3	Installation	7			
3.1	Incoming acceptance, transport, storage	7			
3.2	Installation conditions	7			
3.3	Installation instructions	11			
3.4	Post-installation check	12			
4	Wiring	13			
4.1	Connection to the transmitter	13			
4.2	Post-connection check	13			
5	Commissioning	14			
5.1	Function check	14			
5.2	Calibration	14			
5.3	Setting the wiper	14			
6	Maintenance	15			
6.1	Cleaning the sensor	15			
6.2	Checking the measuring function	15			
6.3	Checking the wiper	16			
6.4	Recalibration	16			
7	Accessories	17			
7.1	Connection accessories	17			
7.2	Installation accessories	17			
7.3	Transmitter	18			
7.4	Cleaning	18			
7.5	Monitoring, service kit, recalibration	18			
8	Troubleshooting	18			
8.1	Troubleshooting instructions	18			
8.2	Checking the sensor	19			
8.3	Return	19			
8.4	Disposal	19			
9	Technical data	20			
9.1	Input	20			
9.2	Performance characteristics	20			
9.3	Environment	20			
9.4	Process	20			
				Index	22

1 Safety instructions

1.1 Designated use

Turbimax W CUS31 is a sensor for nephelometric turbidity measurement in water and wastewater.

The sensor is designed for the following applications:

- All phases of drinking water processing
- Coagulation and flocculation
- Filter rupture monitoring
- Filter backwash
- Control of clear rinsing cycles
- Monitoring of phase separation processes
- Boiler feedwater
- Monitoring of cooling water
- Monitoring of surface waters
- Outlet monitoring of sewage treatment plants
- Monitoring of industrial water discharge
- Recycling of industrial water.

Any other use than the one described here compromises the safety of persons and the entire measuring system and is, therefore, not permitted.

The manufacturer is not liable for damage caused by improper or non-designated use.

1.2 Installation, commissioning and operation

Please note the following items:

- Installation, commissioning, operation and maintenance of the measuring system must only be carried out by trained technical personnel.
The technical personnel must be authorized for the specified activities by the system operator.
- Electrical connection must only be carried out by a certified electrician.
- Technical personnel must have read and understood these Operating Instructions and must adhere to them.
- Before commissioning the entire measuring point, check all the connections for correctness. Ensure that electrical cables and hose connections are not damaged.
- Do not operate damaged products and secure them against unintentional commissioning. Mark the damaged product as being defective.
- Measuring point faults may only be rectified by authorized and specially trained personnel.
- If faults can not be rectified, the products must be taken out of service and secured against unintentional commissioning.
- Repairs not described in these Operating Instructions may only be carried out at the manufacturer's or by the service organization.

1.3 Operational safety

The sensor has been designed and tested according to the state of the art and left the factory in perfect functioning order.

Relevant regulations and European standards have been met.

As the user, you are responsible for complying with the following safety conditions:

- Installation instructions
- Local prevailing standards and regulations.



1.4 Return

If the sensor has to be repaired, please return it *cleaned* to the sales center responsible. Please use the original packaging, if possible.

Please enclose the completed "Declaration of Hazardous Material and De-Contamination" (copy the second last page of these Operating Instructions) with the packaging and the transportation documents.

No repair without completed declaration!

1.5 Notes on safety icons and symbols

-  Warning!
This symbol alerts you to hazards. They can cause serious damage to the instrument or to persons if ignored.
-  Caution!
This symbol alerts you to possible faults which could arise from incorrect operation. They could cause damage to the instrument if ignored.
-  Note!
This symbol indicates important items of information.

2 Identification

2.1 Product structure

Sensor	
A	Standard sensor
W	Sensor with integr. wiper
Cable length	
2	Connecting cable 7 m (23 ft)
4	Connecting cable 15 m (49 ft)
9	Special cable length
Assembly	
A	Without assembly
E	Assembly for bubblefree media
S	Assembly with integr. debubbling system
CUS31-	complete order code

2.2 Scope of delivery

The scope of delivery comprises:

- Turbidity sensor acc. to the version:
 - CUS31-**A
factory-calibrated sensor, without assembly
 - CUS31-**E
installed and factory-calibrated in assembly for bubble-free media,
with fixing bracket
 - CUS31-**S
installed and factory-calibrated in assembly with gas bubble trap,
with fixing bracket
- Operating Instructions BA176C/07/en

If you have any questions, please contact your supplier or your sales center responsible.

3 Installation

3.1 Incoming acceptance, transport, storage

- Make sure the packaging is undamaged!
Inform the supplier about damage to the packaging. Keep the damaged packaging until the matter has been settled.
- Make sure the contents are undamaged!
Inform the supplier about damage to the delivery contents. Keep the damaged products until the matter has been settled.
- Check that the scope of delivery is complete and agrees with your order and the shipping documents.
- The packaging material used to store or to transport the product must provide shock protection and humidity protection. The original packaging offers the best protection. Also, keep to the approved ambient conditions (see "Technical data").
- If you have any questions, please contact your supplier or your sales center responsible.

3.2 Installation conditions

3.2.1 Dimensions

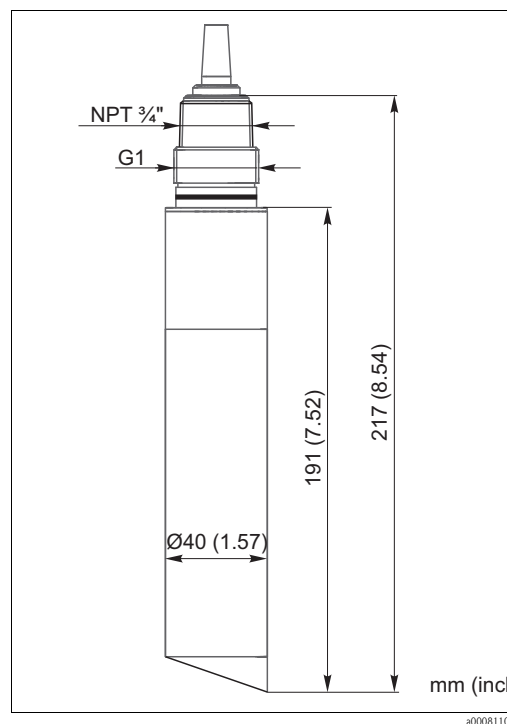

Fig. 1: CUS31

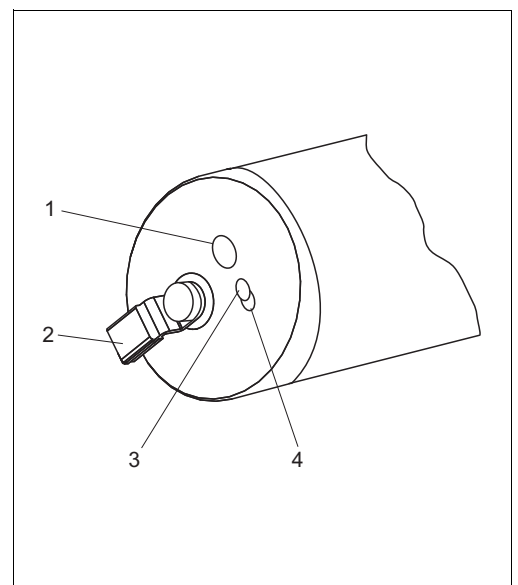

Fig. 2: Sensor optics

- 1 Photodiode (receiver)
- 2 Wiper (optional)
- 3 Photodiode (receiver)
- 4 LED (IR transmitter)

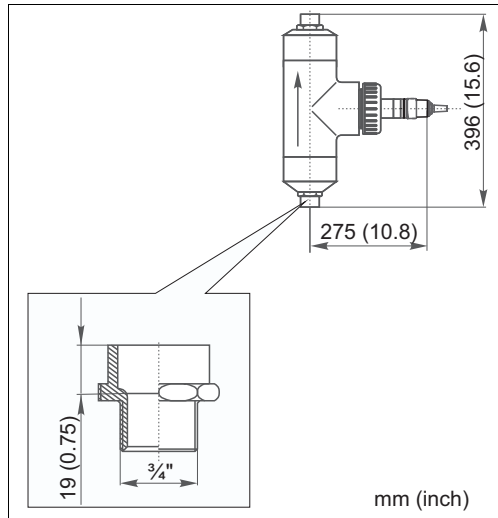

Fig. 3: CUS31-**E (with assembly E)

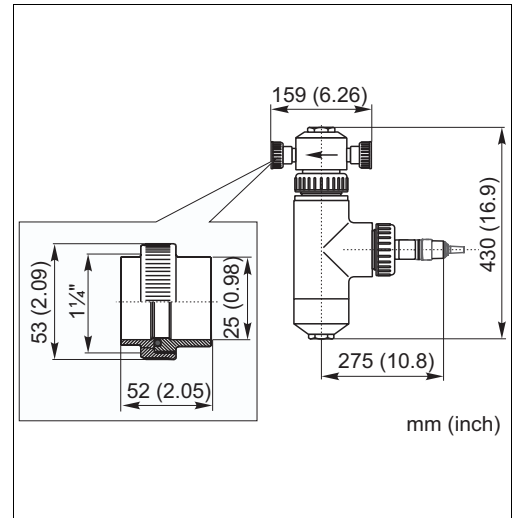

Fig. 4: CUS31-**S (with assembly S)

3.2.2 Wall distance

Installing the sensor in pipework or very close to the wall can cause backscatter which results in a higher sensor signal.

The effective wall or bottom distance can be optimized by aligning the flat sensor side.

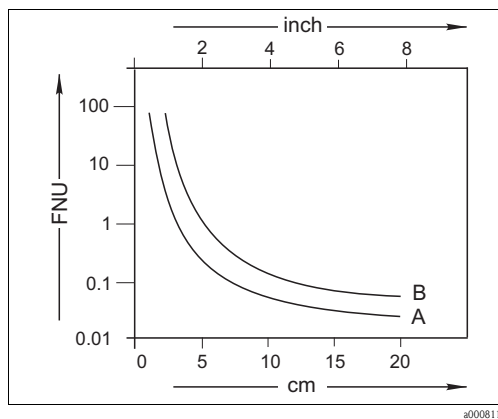

Fig. 5: Effect of the distance from the wall or bottom

- A Dark wall or bottom (non-reflective)
- B Bright wall or bottom (reflective)



Note!

The following generally applies: The lower the turbidity to be measured, the darker the vessel walls should be and the greater the wall distance should also be.

When measuring in drinking water, the wall distance to a dark wall must be **at least 8 cm (3")**.

Bright pipes are not suitable for the drinking water sector.

3.2.3 Pipe installation

The following figure illustrates various installation positions in pipes and indicates whether they are permitted or not.

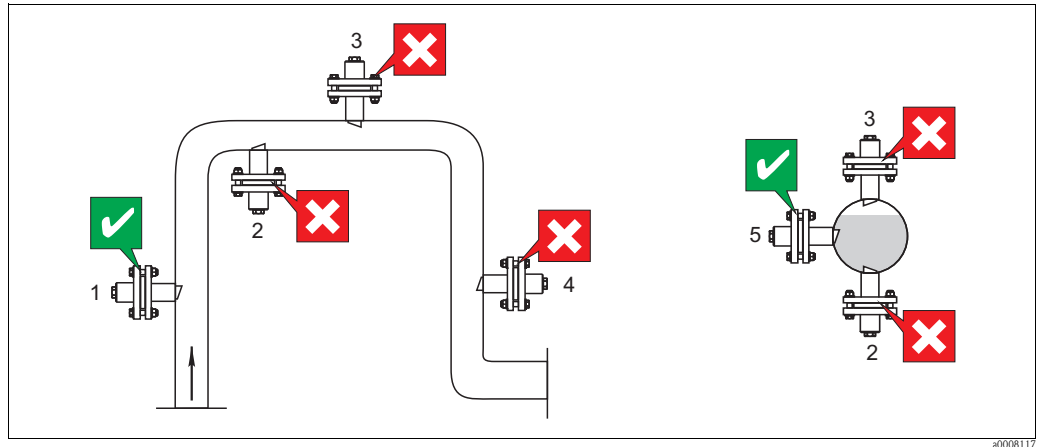

Fig. 6: Orientation and installation positions (with adapter CUA120-A/B resp. retractable assembly CUA451)

- The pipeline diameter must be at least 100 mm (4") if reflective materials (e.g. stainless steel) are used.
- Install the sensor in places with uniform flow conditions.
- Orientate the sensor surface against the medium flow (self-cleaning effect).
- The best installation location is in the ascending pipe (→ Fig. 6, it. 1). Installation is also possible in the horizontal pipe (it. 5).
- Do not install the sensor in places where air may collect or foam bubbles form (it. 3) or where suspended particles may settle (it. 2).
- Avoid installation in the down pipe (it. 4).

3.2.4 Flow operation

- Install the flow assembly as vertical as possible so that the medium flows to the sensor from below.
- Two sensor orientations are possible for every installation:
 - Parallel to the medium flow
Orientation parallel to the medium flow is required when using the CUR 3 spray head.
 - Against the medium flow
Orientation against the medium flow is used to increase the self-cleaning effect in heavily-soiled media (> 15 FNU). The wall reflection is negligible here due to the high absorption.

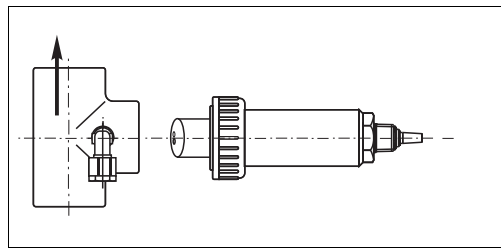

Fig. 7: Parallel to the medium flow

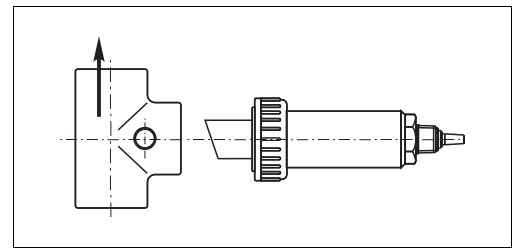

Fig. 8: Against the medium flow



Note!

For turbidities < 5 FNU, use the sensor versions CUS31-**E or CUS31-**S.

3.2.5 Flow operation in the drinking water sector (with special calibration)

When the sensor is ordered with assembly E or S, the sensor is **individually calibrated** in the factory with the assembly ordered.

Therefore, no initial calibration on site is necessary.

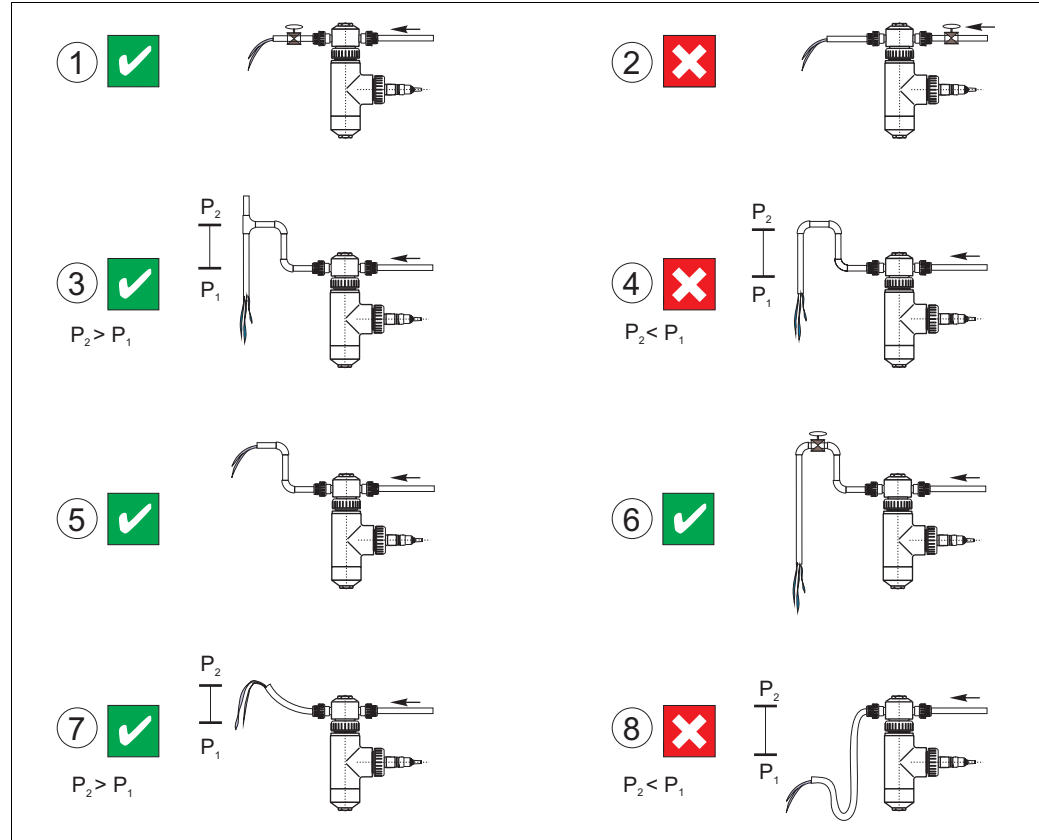



Fig. 9: Installation situations with flow assembly E resp. S

1. Correct: pressure reduction after measurement
Degassing is avoided. The gas in the water remains dissolved.
2. Incorrect: Pressure reduction before measurement
The pressure reduction creates favourable conditions for gas bubble formation.
3. Correct: Outlet of the assembly raised and vented
Gas cannot collect in the upper section of the assembly. The outlet pipe is vented at the highest point. A slight overpressure forms in the assembly as a result of the height difference of the raised outlet.
4. Incorrect: Outlet raised but not vented
A low pressure forms in the assembly if venting via the downcomer outlet pipe does not take place due to too small a cross-section.
5. Correct: Standard application in event of little initial pressure
Slight overpressure due to raised outlet level, no gas collecting in the upper section of the assembly.
6. Limited application: The valve reduces the volume flow

 Note!

The outlet line may not be too thin or too long as otherwise a low pressure forms in the assembly. A vent for the drain line must be present. The outlet must be completely opened at regular intervals as otherwise the raising of the outlet level would not make any sense. If using a tube as the drain line, avoid formation of siphon draw (low points in the tube)! Otherwise venting does not take place.

7. Correct: Tube as outlet line
Must be raised!
8. Incorrect: Tube not raised
A low pressure forms in the assembly which favours gas bubble formation. In addition, low points in the tube result in siphon draw and thereby prevent venting. This results in pressure changes in the assembly.

3.2.6 Immersion operation

When installing the sensor in immersion assemblies, please ensure that a sufficient wall distance is observed during operation.

- For this reason, select an installation location in which a **minimum wall distance of 150 mm (6")** is observed even with varying levels or altered flow profiles. Mounting in a suspended assembly with chain must therefore be avoided.
- The sensor must immerse at least 40 mm (1.57") into the medium.

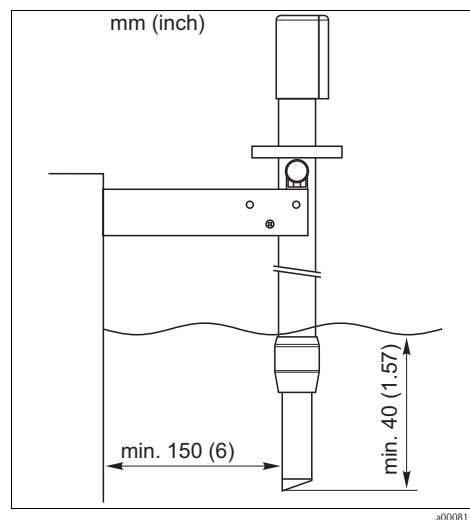

Fig. 10: CYA611 with pendulum frame

3.3 Installation instructions

3.3.1 Measuring system

A complete measuring system comprises:

- Turbidity sensor CUS31
- Transmitter, e.g. Liquisys M CUM253
- Assembly:
 - Flow assembly E or S (each with installed, factory calibrated sensor) or
 - Immersion assembly, e.g. Dipfit W CYA611 or
 - Retractable assembly, e.g. Cleanfit W CUA451

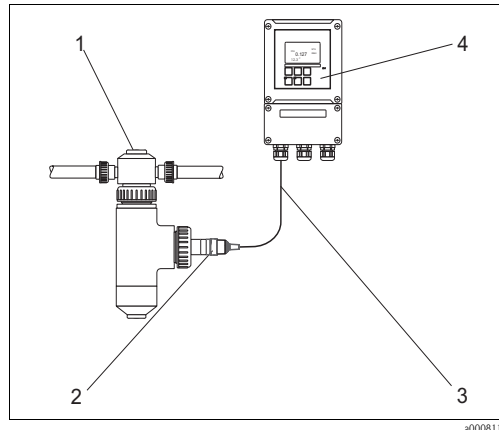

Fig. 11: Measuring system with flow assembly

- 1 Flow assembly S
- 2 CUS31-**S
- 3 Sensor cable
- 4 Transmitter Liquisys M CUM253

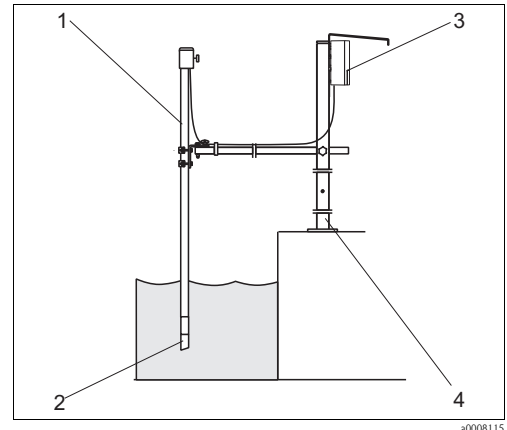

Fig. 12: Measuring system with immersion assembly

- 1 Immersion assembly Dipfit W CYA611
- 2 CUS31-**A
- 3 Transmitter Liquisys M CUM253 (with weather protection cover CYY101)
- 4 Universal assembly holder CYH101

3.3.2 Notes on installation

Proceed as follows for complete installation of a measuring point:

1. Install the retractable or flow assembly (if used) into the process.
2. Connect the water to the rinsing nozzles (if using assembly with cleaning).
3. Install and connect the turbidity sensor.
4. Install the suspended or immersion assembly (if used) into the process.



Caution!

- Follow national grounding regulations when using metal assemblies and installation devices.
- The sensor must be installed in an immersion assembly (e.g. CYA 611) for immersion operation. Do not use the sensor suspended freely from the cable.
- Screw the sensor into the assembly in such a way that the cable does not become twisted.
- Avoid large traction (e.g. by tugging) on the cable.



Note!

- Select a mounting location which can be easily accessed for later calibrations.
- When installing without an assembly, the sensor optics must be immersed **at least 4 cm (1.5")** into the medium.
- Please pay special attention to the installation instructions in the Operating Instructions of the assembly used.

3.4 Post-installation check

Checks	Info
In general: Optical windows free of film? Permissible orientation observed? Medium present?	If no: cleaning (→ "Maintenance") → "Installation conditions" Is the assembly or piping completely filled with medium?
Immersion assembly: Sensor installed in immersion assembly? Protection cap on immersion assembly?	Do not use the sensor suspended freely from the cable. Prevent moisture penetrating the assembly!
Flow assembly/retractable assembly: Sensor installed in flow or retractable assembly?	Ensure the sensor is aligned correctly to the flow direction!
Sensors with wiper	→ "Maintenance"

4 Wiring



Warning!

- The electrical connection must only be carried out by a certified electrician.
- Technical personnel must have read and understood the instructions in this manual and must adhere to them.
- Ensure that there is no voltage at the power cable before beginning the connection work.

4.1 Connection to the transmitter

The sensor is connected to the transmitter by means of a multi-core, shielded measuring cable (fixed cable at the sensor).

To extend the measuring cable, a VBM or RM junction box and a CYK81 extension cable must be used.

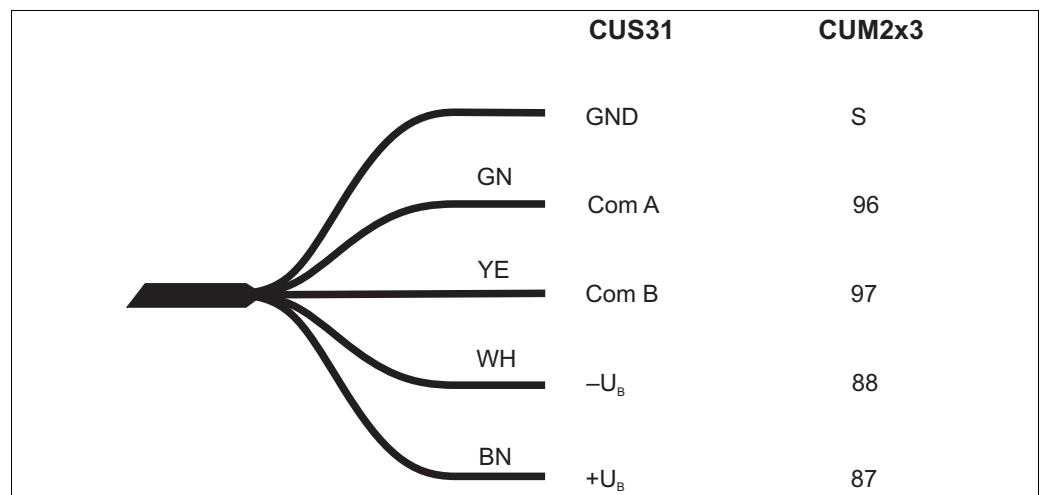

Fig. 13: Measuring cable (fixed cable) resp. extension cable (CYK81)



Note!

Please pay special attention to the instructions on sensor connection in the Operating Instructions of the transmitter.

4.2 Post-connection check

Instrument status and specifications	Remarks
Are the sensor, assembly, junction box or cable damaged?	Visual inspection
Electrical connection	Remarks
Does the supply voltage of the transmitter match the specifications on the nameplate?	110/230 V AC 24 V AC/DC
Are the installed cables strain-relieved and not twisted?	
Is the cable type route completely isolated?	Power cable/signal cable
Are the power supply and signal cable correctly connected to the transmitter?	Use the connection diagram of CxM2x3.
Are all the screws terminals properly tightened?	
Are all the cable entries installed, tightened and sealed?	For lateral cable entries : cable loops downwards for water to be able to drip off.
Are all the cable entries installed downwards or lateral?	

5 Commissioning

5.1 Function check

Before first commissioning, check if:

- the sensor is correctly installed
- the electrical connection is correct.



Warning!

Danger of medium leaking off

Before applying compressed air to an assembly with cleaning facility, make sure the connections are correctly fitted. Otherwise, the assembly may not be inserted into the process.

5.2 Calibration

Each sensor is calibrated in the factory according to standard procedures (ISO 7027 / EN 27027). The wavelength of 880 nm is in the near-infrared range.

The sensor zero point adjustment relates to almost particle-free water (particles < 0.2 µm). The calibration data are saved internally in the sensor as data record 1 and are also documented at the factory by means of the serial number (data cannot be modified).

You can operate the sensor in the “formazine” transmitter operating mode using the factory calibration. The calibration data are automatically taken over by the transmitter once the sensor is connected to the Liquisys M CUM2x3 transmitter and power-up takes place. The measuring point is immediately operational.

You can save some calibration data as data record 2 or 3 (data changeable) without losing the factory calibration in data record 1.



Note!

- Please pay special attention to the instructions on wall distance.

An installation adjustment, (see Operating Instructions BA200C/07/en Liquisys M CUM2x3), may have to be performed.

- **For drinking water applications, versions CUS31-**E or CUS31-**S:**

The sensor is already installed in the assembly and is calibrated with the assembly. Recalibration at a later stage is always performed in conjunction with the assembly.

5.3 Setting the wiper



Note!

Only for versions CUS31-W**!

You can set the wiping duration and the wiping intervals via the transmitter, (see Liquisys M CUM2x3 Operating Instructions).

The factory setting specifies a wiping time of 30 seconds and an interval of 120 minutes. These settings are optimum for drinking water applications with little gas-bubble formation. This prevents film formation from the build-up of lime, metal oxides etc. and biological growth.

The interval time must be reduced to 20 or 30 minutes for more heavily-soiled media (higher levels of lime, oxide and biological growth). The wiping time can be reduced to 20 seconds.

Rapidly-forming gas bubbles which distort the measurements can occur in some applications. In such instances, set the interval time to 3 to 5 minutes and the wiping time to 5 seconds. In most cases the gas bubbles can be removed by turning the wiper once.



Caution!

Never move the wiper manually!

6 Maintenance

You must carry out maintenance tasks at regular intervals. For this, specify the maintenance times in an operations logbook or operations calendar.

The following tasks must be carried out:

- Cleaning the sensor
- Checking the measuring function
- Checking the wiper
- Recalibration

You can find the description of the mentioned maintenance tasks in the following chapters.

6.1 Cleaning the sensor

Contamination of the sensor can impact the measurement up to the point that measurement no longer functions, e.g. by:

- Thick film build-up on the sensor optics
Film build-ups can cause bad measurement results.
- Wiper clogging
Causes bad measurement results.

The sensor must be cleaned regularly to ensure reliable measurement. The frequency and intensity of the cleaning depend on the medium.

The sensor must be cleaned:

- prior to every calibration
- if necessary, regularly during the operation
- prior to returning the sensor for repair.

Type of contamination	Cleaning measures
Lime deposits	Immerse the sensor in 1-5 % hydrochloric acid (a few minutes).
Dirt particles on the optics	Mechanically clean the sensor head with water and a suitable brush or sponge.
Fibres on the wiper axis	Remove manually.



Caution!

After cleaning, rinse the sensor with water.



Note!

For automatic cleaning we recommend equipping the measuring point with a fully-automatic cleaning system, e.g. Chemoclean (Accessories).

6.2 Checking the measuring function

1. Remove the sensor from the medium.
2. Clean and dry the sensor.
3. Check the slope using CUY22 check unit. A stable measured value (between 2 and 6 FNU) must register. The exact value is not of importance but must be repeatable for the same sensor.



Note!

If measuring at air, a reliable measured value will not register (due to undefined refractive conditions).

6.3 Checking the wiper



Note!

Only for versions CUS31-W**

Remove the sensor from the medium and carry out the following checks:

Visual inspection	<ul style="list-style-type: none"> ■ Is the wiper still present? ■ Is the cap on the screw still present? ■ Is the screw or wiper arm secure? ■ What is the condition of the wiper rubber? <p>Replace missing or worn parts. If necessary, retighten the screw (holding the wiper arm in position).</p>
Function checks	<p>When voltage is applied, the wiper moves to the end position (at the side of the optical windows).</p> <p>The check can be carried out using the "AUTO" key of the Liquisys M CUM2x3 transmitter.</p> <p>Enter Code 22, press the <input type="button" value="E"/> key and then keep the <input type="button" value="A"/> key pressed until the wiper function appears on the display. The wiper can be switched on or off using the <input type="button" value="+"/> or <input type="button" value="-"/> keys. The wiper should not turn 360 °, but should only go from end position to end position and back.</p>

6.4 Recalibration

At the factory

- Remove the sensor (versions CUS31-**E/S including the assembly) and send it cleaned to your supplier or to your supplier resp. to your E+H sales centre for recalibration (order no. 50081264).
- Please use the original packaging, if possible.
- Enclose of a copy of the duly completed Declaration of decontamination (second-last page of these Operating Instructions) with the packaging and delivery documents.
- Recalibration is carried out in the factory as per ISO 7027 / EN 27027 (traceable to formazine standard).

On-site

You have the following options in the "Calibration" menu of the transmitter:

- One-point calibration
- Three-point calibration
- Installation adjustment
- Correction function
- Adjust calibration data



Note!

Please refer to the Operating Instructions of the Liquisys M CUM2x3 transmitter for detailed instructions!

7 Accessories

7.1 Connection accessories

CYK81 measuring cable

- Non-terminated measuring cable for extension of sensor cables of e.g. Memosens, CUS31/CUS41
- 2 wires, twisted pair with shield and PVC-sheath (2 x 2 x 0.5 mm² + shield)
- Sold by the meter, order no. 51502543

Junction box VBM

- For cable extension
- 10 terminals
- Cable entries: 2 x Pg 13.5 or 2 x NPT ½"
- Material: aluminum
- Ingress protection: IP 65 (≅ NEMA 4X)
- Order numbers:
 - cable entries Pg 13.5: 50003987
 - cable entries NPT ½": 51500177

Junction box RM

- For cable extension (e.g. for Memosens sensors or CUS31/CUS41)
- 5 terminals
- Cable entries: 2 x Pg 13.5
- Material: PC
- Ingress protection: IP 65 (≅ NEMA 4X)
- Order no.: 51500832

7.2 Installation accessories

Immersion assembly holder CYH101

- For pH, ORP, oxygen, conductivity assemblies and for oxygen and turbidity sensors;
- Ordering acc. to product structure (Technical Information TI092C/07/en)

Immersion assembly Dipfit W CYA611

- For sensor immersion in basins, open channels and tanks, PVC
- Ordering acc. to product structure, see Technical Information TI166C/07/en

Flange adapter CUA120

- for CUS31/CUS41
- Ordering information:
 - CUA120-A for welding flange, h=47 mm (1.85")
 - CUA120-B for welding flange, h=93 mm (3.66")

Flow assembly Flowfit CUA250

- for CUS31/CUS41
- ordering acc. to product structure (Technical Information TI096C/07/en)

Retractable assembly Cleanfit CUA451

- retractable assembly with ball valve; for turbidity sensors; material: stainless steel
- ordering acc. to product structure (Technical Information TI369C/07/en)

Welding rinse socket DN 65

- order no. 51500912

Welding rinse socket DN 50 / PN 16

- order no. 55001306

7.3 Transmitter

Liquisys M CUM 223/253

- Turbidity transmitter
- Panel mounting or field housing
- Optional with Hart® or Profibus communication
- Ordering acc. to product structure, see Technical Information TI200C/07/en

7.4 Cleaning

Chemoclean

- Injector CYR10 and program sequencer CYR20
- Ordering acc. to product structure, see Technical Information (TI046C/07/en)

Chemoclean CUR3

- Spray head for flow assemblies CUA250 and COA250
- order no. CUR3-1

7.5 Monitoring, service kit, recalibration

CUY22

- Check unit for CUS31 for checking the sensor
- order no. 51504477

Service kit CUY31

- 3 spare wiper arms
- order no. 50089252

Recalibration CUS31

- Calibration as per ISO 7027 / EN 27027
- order no. 50081264

8 Troubleshooting

8.1 Troubleshooting instructions

Troubleshooting must take account of the whole measuring system:

- Transmitter
- Electrical leads and connectors
- Assembly
- Sensor

The possible causes of failure listed in the following table primarily refer to the sensor.

Problem	Check	Remedy
No display, no sensor reaction	Mains voltage at transmitter? Sensor connected correctly? Medium flow present? Film formation on optical windows?	Connect mains voltage. Set up correct connection. Create flow. Clean the sensor.
Reading too high or too low	Film formation on optical windows? Gas bubbles present? Sensor calibrated? Check data record. Check with check unit.	Clean the sensor. Remove gas bubbles. Calibrate. Change, if necessary. Check in factory.
Reading greatly fluctuating	Gas bubbles present? Check mounting location.	Remove gas bubbles. Select other mounting location.

Problem	Check	Remedy
Measured value jump to 9999 FNU	Gas bubble formation on the optical windows?	Change orientation. Adjust wiper interval. Increase gas bubble factor in Liquisys M CUM2x3 menu.
Error 8	Water in sensor? Cable breakage? Incorrect cable connection?	Send sensor to service. Check cable. Check wiring.
Wiper does not find end position	Visual inspection: Initial position not in end position?	Send sensor to service.



Note!

Please pay special attention to the instructions on handling errors in the Operating Instructions of the transmitter. Check the transmitter, if necessary.

8.2 Checking the sensor



Caution!

The sensor may only be checked by authorised and specially trained personnel. You also require a voltmeter.

Check	Measure	Set point
Voltage check	Check supply voltage at transmitter (sensor connected)	10 to 16 V between terminals 87 and 88
Slope check	Check slope using CUY22 check unit	Stable measured value (1 to 6 FNU)
Zero point check	Produce zero water by filtration (0.2 µm)	< 0.1 FNU



Note!

If the values deviate from the set points, carry out trouble-shooting as per the trouble-shooting instructions or contact your sales center.

8.3 Return

If the sensor has to be repaired, please return it *cleaned* to the sales center responsible. Please use the original packaging, if possible.

Please enclose the completed "Declaration of Hazardous Material and De-Contamination" (copy the second last page of these Operating Instructions) with the packaging and the transportation documents.

No repair without completed declaration!

8.4 Disposal

The device contains electronic components and must therefore be disposed of in accordance with regulations on the disposal of electronic waste. Please observe local regulations.

9 Technical data

9.1 Input

Measuring principle nephelometric acc. to ISO 7027 / EN 27027

Measured variable Turbidity

Measuring range 0.000 to 9999 FNU
0.00 to 3000 ppm
0.0 to 3.0 g/l
0.0 to 200 %

9.2 Performance characteristics

Maximum measured error < 5 % (min. 0.02 FNU) of measured value
(system measured error related to the primary formazine standard / tracing according to ISO 5725 and ISO 7027 / EN 27027)

Repeatability < 1 % (min. 0.01 FNU) of measured value

Wavelength 880 nm

Factory calibration traceable to formazine standard and SiO₂

9.3 Environment

Storage temperature -20 to 60 °C (0 to 140 °F)

Ingress protection IP 68

9.4 Process

Process temperature range -5 to 50 °C (20 to 120 °F)

Process pressure 1 to 6 bar (15 to 87 psi)

Temperature pressure diagram

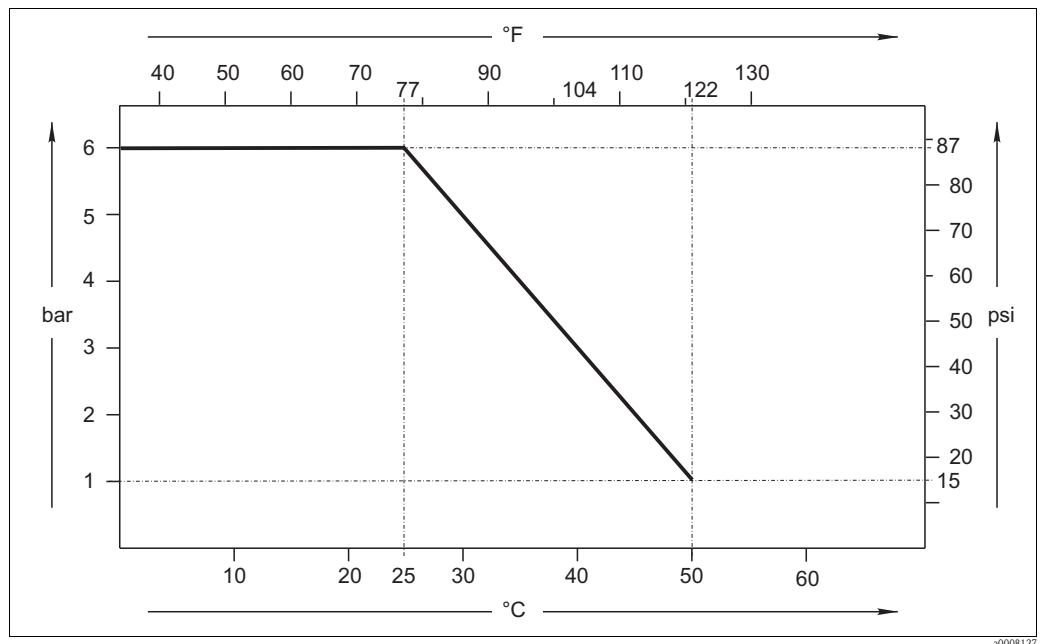

Fig. 14: Temperature pressure diagram

9.5 Mechanical construction

Design, dimensions

see "Installation conditions"

Materials

Sensor carrier plate, shaft	PVC / PPS GF 40 (polyphenylene sulfide with 40% glass-fibre)
Optical windows	Sapphire
Flow assemblies E and S	PE
Wiper (CUS31-W** only)	Rubber
Cable	TPEO (polyolefine based elastomer), -40 to 130 °C (-40 to 260 °F)

Process connections

G1 and NPT 3/4"

Temperature sensor

NTC resistor 30K at 25 °C (77 °F)

Index

A

Accessories	
Assemblies	17
Assembly holder CYH101	17
Compact chlorine system	17
Connection accessories	17
Transmitter	18
Adjustment	14
Assembly holder CYH101	17

C

Cable length	21
Calibration	14, 16
Checking	
Connection	13
Function	14
Checking the sensor	19
Cleaning	15, 18
Commissioning	4, 14
Connection	13
Checking	13

D

Design, dimensions	21
Designated use	4
Dimensions	7
Disposal	19
Drinking water	10

E

Electrical connection	13
Environment	20

F

Factory calibration	20
Flow mode	11
Flow operation	9

I

Immersion operation	11
Incoming acceptance	7
Ingress protection	20
Installation	4, 7
Measuring system	12
Installation instructions	11

M

Maintenance	15
Materials	21
Maximum measured error	20
Measured value	20
Measured variable	20
Measuring function	15
Measuring principle	20
Measuring range	20
Measuring system	11–12

O

Operation	4
Operational safety	4

P

Performance characteristics	20
Pipework	9
Process	20
Process connections	21
Process pressure	20
Process temperature range	20
Product structure	6

R

Recalibration	18
Repeatability	20
Return	5, 19

S

Safety icons	5
Scope of delivery	6
Service kit	18
Storage	7
Storage temperature	20
Symbols	5

T

Technical data	20
Temperature compensation	21
Temperature pressure diagram	21
Temperature sensor	21
Transport	7
Troubleshooting instructions	18

U

Use	4
-----	---

W

Wall distance	8
Wavelength	20
Wiper	14, 16
Wiring	13

Declaration of Hazardous Material and De-Contamination *Erklärung zur Kontamination und Reinigung*

RA No.

Please reference the Return Authorization Number (RA#), obtained from Endress+Hauser, on all paperwork and mark the RA# clearly on the outside of the box. If this procedure is not followed, it may result in the refusal of the package at our facility.
Bitte geben Sie die von E+H mitgeteilte Rücklieferungsnummer (RA#) auf allen Lieferpapieren an und vermerken Sie diese auch außen auf der Verpackung. Nichtbeachtung dieser Anweisung führt zur Ablehnung ihrer Lieferung.

Because of legal regulations and for the safety of our employees and operating equipment, we need the "Declaration of Hazardous Material and De-Contamination", with your signature, before your order can be handled. Please make absolutely sure to attach it to the outside of the packaging.

Aufgrund der gesetzlichen Vorschriften und zum Schutz unserer Mitarbeiter und Betriebseinrichtungen, benötigen wir die unterschriebene "Erklärung zur Kontamination und Reinigung", bevor Ihr Auftrag bearbeitet werden kann. Bringen Sie diese unbedingt außen an der Verpackung an.

Type of instrument / sensor

Geräte-/Sensortyp _____

Serial number

Seriennummer _____

Used as SIL device in a Safety Instrumented System / Einsatz als SIL Gerät in Schutzeinrichtungen

Process data/ Prozessdaten

Temperature / Temperatur _____ [°F] _____ [°C]

Pressure / Druck _____ [psi] _____ [Pa]

Conductivity / Leitfähigkeit _____ [µS/cm]

Viscosity / Viskosität _____ [cp] _____ [mm²/s]

Medium and warnings

Warnhinweise zum Medium



	Medium /concentration <i>Medium /Konzentration</i>	Identification CAS No.	flammable <i>entzündlich</i>	toxic <i>giftig</i>	corrosive <i>ätzend</i>	harmful/ irritant <i>gesundheitsschädlich/ reizend</i>	other * <i>sonstiges*</i>	harmless <i>unbedenklich</i>
Process medium <i>Medium im Prozess</i>								
Medium for process cleaning <i>Medium zur Prozessreinigung</i>								
Returned part cleaned with <i>Medium zur Endreinigung</i>								

* explosive; oxidising; dangerous for the environment; biological risk; radioactive

* *explosiv; brandfördernd; umweltgefährlich; biogefährlich; radioaktiv*

Please tick should one of the above be applicable, include safety data sheet and, if necessary, special handling instructions.

Zutreffendes ankreuzen; trifft einer der Warnhinweise zu, Sicherheitsdatenblatt und ggf. spezielle Handhabungsvorschriften beilegen.

Description of failure / Fehlerbeschreibung _____

Company data / Angaben zum Absender

Company / Firma _____	Phone number of contact person / Telefon-Nr. Ansprechpartner: _____
Address / Adresse _____	Fax / E-Mail _____
_____	Your order No. / Ihre Auftragsnr. _____

"We hereby certify that this declaration is filled out truthfully and completely to the best of our knowledge. We further certify that the returned parts have been carefully cleaned. To the best of our knowledge they are free of any residues in dangerous quantities."

"Wir bestätigen, die vorliegende Erklärung nach unserem besten Wissen wahrheitsgetreu und vollständig ausgefüllt zu haben. Wir bestätigen weiter, dass die zurückgesandten Teile sorgfältig gereinigt wurden und nach unserem besten Wissen frei von Rückständen in gefahrbringender Menge sind."

(place, date / Ort, Datum)

Name, dept./Abt. (please print / bitte Druckschrift)

Signature / Unterschrift

www.endress.com/worldwide

Endress+Hauser 
People for Process Automation

