



Füllstand



Druck



Durchfluss



Temperatur



Flüssigkeits-
analyse



Registrierung



Systeme
Komponenten



Services



Solutions

Technical Information

EngyCal[®] RH33

BTU meter

Custody transfer BTU meter for recording and billing the heat/cold quantity given off by water, water/glycol mixtures or other liquids



Highlights

- Verified and certified reliability and accuracy
- Transparent energy consumption helps you save on energy costs
- Swift commissioning thanks to easy operation in selectable language and plain-text display

Application

- Recording and billing the quantities of heat and cold given off by liquids or steam
- Calculation of corrected volume, temperature differential, heat quantity, power, K-factor
- Bidirectional measurement in heating and cooling circuits
- Energy cost optimization and monitoring in buildings

Your benefits

- Custody transfer journal and logbook with comprehensive diagnostics functionality
- Rate counter for optimized cost transparency
- Optimum integration into control and analytical systems using the analog output and various bus interfaces
- High-precision sensor matching in the meter means temperature sensors can be replaced individually; no need for temperature sensor pairs to accurately calculate the heat differential
- Approval for custody transfer as per the MID (EN1434 water/liquids) and OIML R75
- Calculations in accordance with IAWPS-IF97
- CE, UL-listed, CSA GP

Function and system design

Measuring principle

The EngyCal® RH33 BTU meter is used to measure the heat and cold in systems with liquid heat transfer fluids. The meters are easy to install and read. Thanks to its verified long-term stability and high-precision measurements, the device helps optimize processes and control costs in the process. Comprehensive data analysis options in the Field Data Manager software (see accessories) identify potential areas for cost reduction and help reduce outlays for measuring devices during the life cycle.

Measuring system

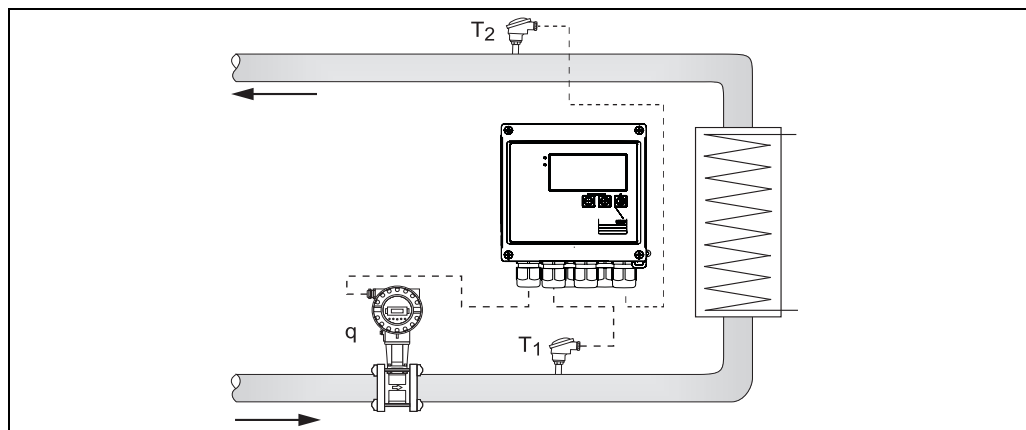

Measuring system with EngyCal®, 2x temperature sensor pairs and flow sensor

Functions

Energy calculation

EngyCal® RH33 calculates the thermal energy of water, glycol/water mixtures or other liquids such as thermal oils in accordance with EN1434.

Calculation basis: IAWPS-IF97

Calculated values:

- Mass
- Density
- Volume
- Temperature differential
- Enthalpy & enthalpy differential
- Power
- DP-Flow compensation

Temperature-sensor matching in the computer

The temperature sensors are paired internally in the EngyCal® RH33 by aligning the sensor characteristic curves via Callendar-van-Dusen coefficients. Callendar-van-Dusen coefficients are determined by calibrating the temperature sensor.

The internal alignment function makes it possible to use unpaired sensors, and to replace one sensor independently of the second sensor while maintaining or improving accuracy levels (compared to using paired sensors).

Logbook

In the logbook, all parameter changes (for the "Approval for custody transfer" option), alarms and events are documented in a non-volatile memory such that they are tamper-proof.

Approval for custody transfer and custody transfer journal

EngyCal® RH33 has a custody transfer switch, which disables configuration areas that are relevant for custody transfer.

The custody transfer switch is located inside the device. The housing is lead-sealed.

The switch is enabled before delivery if the device is ordered with approval for custody transfer. Following this, it is possible to reconfigure relevant device settings three times. All changes to the parameters are logged in the custody transfer journal and time-stamped.

The switch can only be reset by the manufacturer.

Bidirectional measurement (optional)

EngyCal® RH33 facilitates the bidirectional measurement and calculation of heat quantity. The setting for detecting the flow direction can be changed via digital inputs. This option cannot be combined with the rate function.

Rate models (optional)

Two user-programmable rate counters allow invoicing on specific billing dates (due date invoicing) and flexible rate models without the need for intermediate meter reading.

Real time clock (RTC)

The device has a real time clock that can be synchronized via a free digital input or using the operating software.

Accuracy: 15 minutes per year
Power reserve (no power from mains): 1 week

Display

The back-lit display can show up to 3 measured values or meter readings at the same time.

Technology: LCD, transfective, black/white
Resolution: 160 x 80 dot matrix
Backlighting: LED, white; color switches to red in an alarm condition
Active display area: 70 mm x 34 mm

Data storage

Any data stored are retained if the power supply fails.

Application data

The device has a non-volatile memory for meter readings, analysis intervals, diagnostics lists and the event log.

Device data / electronic nameplate

The device saves the device data / electronic nameplate, such as the serial number, traceability tag, versions etc. in the Flash memory.

Custody transfer switch

The EngyCal® RH33 BTU meter has a custody transfer switch that disables specific areas of the configuration.

This switch is located inside the housing and is sealed with a lead seal.

Cycle time

The cycle time is 250 ms or 500 ms respectively when using one or two RTD inputs.

Reaction time

In the case of analog signals, the reaction time is the time between the change at the input and the time when the output signal is equivalent to 90% of the full scale value. The reaction time increases if one of the RTD inputs is used.

Input	Output	Time [ms]
Current	Current	≤ 600
Current	Relay/digital output	≤ 600
RTD	Current/ relay/digital output	≤ 600
Cable open circuit detection	Current/ relay/digital output	≤ 600
Cable open circuit detection, RTD	Current/ relay/digital output	≤ 1100
Pulse input	Pulse output	≤ 600

Input

Current/pulse input

This input can be used either as a current input for 0/4 to 20 mA signals (not if the approval for custody transfer option has been selected) or as a pulse/frequency input.

The input is galvanically isolated (500 V testing voltage towards all other inputs and outputs).

Current input

Measuring range:	0/4 to 20 mA + 10 % over range
Accuracy:	0.1 % of full scale value
Temperature drift:	0.01 %/K of full scale value
Loading capacity:	Max. 50 mA, max. 2.5 V
Input impedance (load):	50 Ω
HART® signals	Not affected
A/D converter resolution:	20 bit

Pulse/frequency input

The pulse/frequency input can be configured for different frequency ranges:

- Pulses and frequencies up to 12.5 kHz
- Pulses and frequencies up to 25 Hz (range filters out bounce contacts, max. bounce time: 5 ms)

Minimum pulse width:

Range up to 12.5 kHz	40 μ s
Range up to 25 Hz	20 ms

Maximum permissible contact bounce time:

Range up to 25 Hz	5 ms
-------------------	------

Pulse input for active voltage pulses and contact sensors as per EN 1434-2, Class IB and IC:

Non-conductive state	≤ 1 V
Conductive state	≥ 2 V
No-load supply voltage:	3 V to 6 V
Current limiting resistance in the power supply (pull-up at input):	50 k Ω to 2 M Ω
Maximum permissible input voltage:	30 V (for active voltage pulses)

Pulse input for contact sensors as per EN 1434-2, Class ID and IE:

Low-level	≤ 1.2 mA
High-level	≥ 2.1 mA
No-load supply voltage:	7 V to 9 V
Current limiting resistance in the power supply (pull-up at input)	562 Ω to 1 k Ω

Not suitable for active input voltages

Current/pulse input:

Low-level	≤ 8 mA
High-level	≥ 13 mA
Loading capacity:	Max. 50 mA, max. 2.5 V
Input impedance (load):	50 Ω

Accuracy during frequency measurement:

Basic accuracy:	0.01 % of measured value
Temperature drift:	0.01 % of measured value over entire temperature range

2 x current/RTD input

These inputs can be used either as current inputs (0/4 to 20 mA; not if the approval for custody transfer option has been selected) or as resistance temperature detector (RTD) inputs. It is also possible to configure one input as a current input and the other as an RTD input.

The two inputs are galvanically connected but galvanically isolated from the other inputs and outputs (testing voltage: 500 V).

Current input

Measuring range: 0/4 to 20 mA + 10 % over range
 Accuracy: 0.1 % of full scale value
 Temperature drift: 0.01 %/K of full scale value
 Loading capacity: Max. 50 mA, max. 2.5 V
 Input impedance (load): 50 Ω
 A/D converter resolution: 24 bit
 HART® signals are not affected.

RTD input

Pt100, Pt500 and Pt1000 resistance temperature detectors can be connected to this input.

Measuring ranges:
 Pt100_exact: -200°C to 300°C
 Pt100_wide: -200°C to 600°C
 Pt500: -200°C to 300°C
 Pt1000: -200°C to 300°C
 Connection method: 2-, 3- or 4-wire connection
 Accuracy:
 4-wire: 0.06% of measuring range
 3-wire: 0.06% of measuring range + 0.8 K
 Temperature drift: 0.01 %/K of measuring range
 Delta T measurement (differential measurement between the two RTD inputs): 0.03°C
 Characteristic curves: DIN EN 60751:2008 IPTS-90
 Max. cable resistance: 40 Ω
 Cable open circuit detection: Outside the measuring range

Digital inputs

Depending on the device version, two digital inputs are available for switching the following functions.

Digital input 1	Digital input 2
Activate rate counter 1 Time synchronization Lock device	Activate rate counter 2 Change flow direction

Output

Current/pulse output

This output can be used either as a 0/4 to 20 mA current output or as a voltage pulse output. The output is galvanically isolated (500 V testing voltage towards all other inputs and outputs).

Current output

Output range:	0/4 to 20 mA + 10 % over range
Load:	0 to 600 Ω (as per IEC 61131-2)
Accuracy:	0.1 % of full scale value
Temperature drift:	0.01 %/K of full scale value
Inductive load:	Max. 10 mH
Capacitance load:	Max. 10 μ F
Ripple:	Max. 12 mVpp on 600 Ω for frequencies < 50 kHz
D/A converter resolution:	14 bit

Pulse output

Frequency:	Max. 12.5 kHz
Pulse width:	Min. 40 μ s
Voltage level:	Low: 0 to 2 V High: 15 to 20 V
Maximum output current:	22 mA
Short-circuit proof (current limiting: max. 30 mA)	

2 x relay output

The relays are designed as NO contacts. The output is galvanically isolated (1500 V testing voltage towards all other inputs and outputs).

Max. relay switching capacity:	AC: 250 V, 3 A DC: 30 V, 3 A
Minimum contact load:	10 V, 1 mA
Max. switching cycles:	$>10^5$

2 x digital output (open collector)

The two digital inputs are galvanically isolated from one another and from all the other inputs and outputs (testing voltage: 500 V). The digital outputs can be used as status or pulse outputs.

Frequency:	Max. 1 kHz
Pulse width:	Min. 500 μ s Max. ?
Current:	Max. 120 mA
Voltage:	Max. 30 V
Voltage drop:	Max. 2 V in conductive state
Maximum load resistance:	10 k Ω

Auxiliary voltage output (transmitter power supply)

The auxiliary voltage output can be used to power the transmitter or control the digital inputs. The auxiliary voltage is short-circuit proof and galvanically isolated (500 V testing voltage towards all other inputs and outputs).

Output voltage:	24 V DC \pm 15% (not stabilized)
Output current:	Max. 70 mA
HART® signals are not affected.	

Communication interfaces

A USB interface (with CDI protocol), and optionally Ethernet, are used to configure the device and read out the values. ModBus, M-Bus and BACnet are also available as optional communication interfaces. None of the interfaces has a modifying effect on the device in accordance with PTB Requirement PTB-A 50.1.

USB device	Specification: USB 2.0 Speed: Full speed (max. 12 MBit/sec) Socket: Type B Max. cable length: 3 m
Ethernet TCP/IP	<p>The Ethernet interface is optional, and cannot be combined with other optional interfaces. It is galvanically isolated (testing voltage: 500 V). A standard patch cable (e.g. CAT5E) can be used to connect the Ethernet interface. A special cable gland is available for this purpose which allows users to guide pre-terminated cables through the housing. Via the Ethernet interface, the device can be connected to office equipment using a hub or a switch. Office Equipment Standard EN 60950 must be taken into consideration to ensure correct safety distances.</p> <p>Standard: 10/100 Base-T/TX (IEEE 802.3) Socket: RJ-45 Max. cable length: 100 m Link LED: Orange Activity LED: Green</p>
Modbus TCP	<p>The Modbus TCP interface is optional, and cannot be ordered with other optional interfaces. It is used to connect the device to higher-order systems to transmit all measured values and process values. The Modbus TCP interface is physically identical to the Ethernet interface.</p>
Modbus RTU	<p>The Modbus RTU (RS-485) interface is optional, and cannot be ordered with other optional interfaces. It is galvanically isolated (testing voltage: 500 V) and used to connect the device to higher-order systems to transmit all measured values and process values. It is connected via a 3-pin plug-in terminal.</p>
M-Bus	<p>The M-Bus (Meter Bus) interface is optional, and cannot be ordered with other optional interfaces. It is galvanically isolated (testing voltage: 500 V) and used to connect the device to higher-order systems to transmit all measured values and process values. It is connected via a 3-pin plug-in terminal.</p>

Terminal assignment

Electrical connection (circuit diagrams)

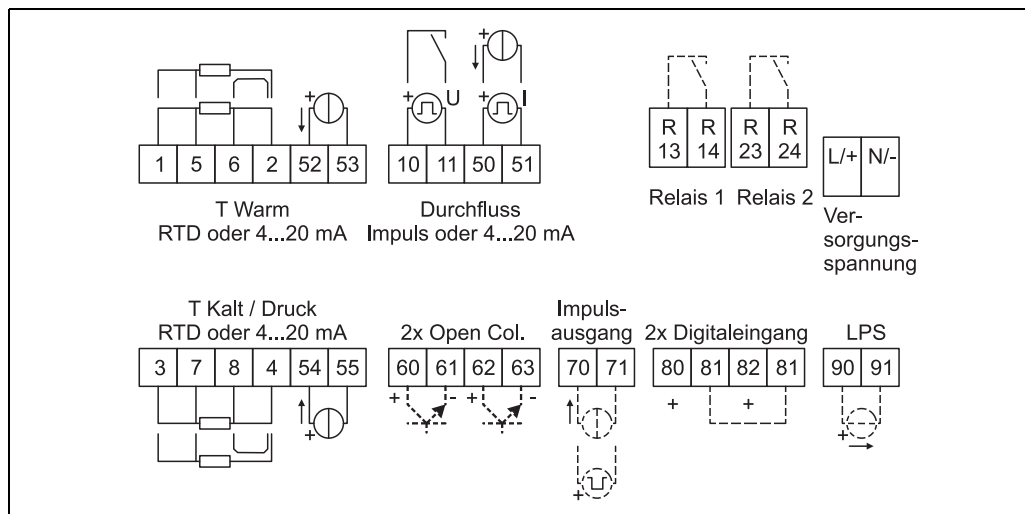

Terminal assignment of the EngyCal® RH33

Supply voltage

- Low-voltage power unit: 100 to 230 V AC (-15% / +10%) 50/60 Hz
- Extra-low voltage power unit:
 - 24 V DC (-50% / +75%)
 - 24 V AC ($\pm 50\%$) 50/60 Hz

An overload protection unit (rated current ≤ 10 A) is required for the power cable.

Power consumption

8 to 26 VA (depending on the device version)

Interface connection data

USB

- Connection: type B socket
- Transmission protocol: USB 2.0
- Transmission rate: full speed, max. 12 Mbit/s

Ethernet

- Connection: RJ45
- Transmission protocol: 10/100 Base-T/TX (IEEE 802.3)
- Transmission rate: max. 100 Mbit/s

RS485

- Connection: 3-pin plug-in terminal
- Transmission protocol: RTU
- Transmission rate: 2400/4800/9600/19200/38400/76800
- Parity: choose from none, even, odd

Performance characteristics

Reference operating conditions

- Power supply 230 V AC \pm 10%; 50 Hz \pm 0.5 Hz
- Warm-up time > 2 h
- Ambient temperature 25 °C \pm 5 K
- Humidity 39% \pm 10% RH

Arithmetic unit

Medium	Variable	Range
Water	Temperature measuring range	0 to 300 °C
	Maximum temperature differential range ΔT	0 to 300 K
	Error limit for ΔT	3 to 20 K < 1.0% of measured value 20 to 250 K < 0.3% of measured value
	Arithmetic unit accuracy class	As per EN 1434-1 / OIML R75 (< 1.5 %)
	Measurement and calculation interval	500 ms
Steam	Temperature measuring range	0 to 600 °C
	Pressure measuring range	0 to 1000 bar
	Measurement and calculation interval	500 ms

Installation

Installation instructions

Mounting location

Wall/pipe mounting, panel or top-hat rail as per IEC 60715

Orientation

The orientation is only determined by the legibility of the display.

Environment

Ambient temperature range

-20 to +60 °C (-4 to +140 °F)

Storage temperature

-30 to +70 °C (-22 to +158 °F)

Climate class

As per IEC 60 654-1 Class B2, as per EN 1434 ambient class C

Electr. safety

As per IEC 61010-1, UL61010 and CAN C22.2 No 1010-1.

- Protection class I
- Overvoltage category II
- Pollution degree 2
- Overload protection \leq 10 A
- Operating altitude: up to 3000 m above MSL

Degree of protection

- Panel mounting: IP65 front panel, IP20 rear panel
- Top-hat rail: IP20
- Field housing: IP66, NEMA4x (for cable gland with double seal insert: IP65)

Electromagnetic compatibility

As per EN 1434-4, EN 61326 and Namur NE21

Mechanical construction

Design, dimensions

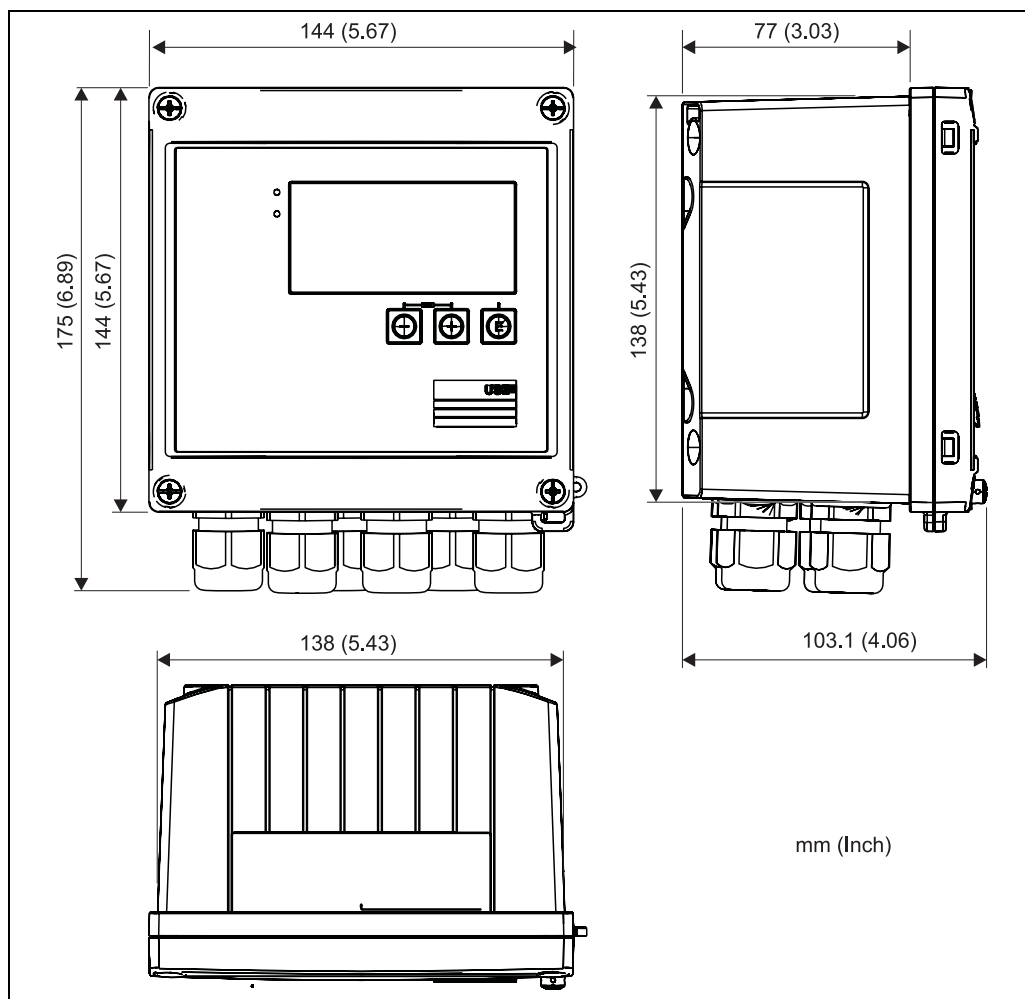

BTU meter housing; dimensions in mm (dimensions in inches in brackets)

Weight	Approx. 500 g (17.6 oz)
Material	Housing: fiber-glass reinforced plastic, PBT-GF30
Terminals	Spring terminals, 2.5 mm ² (14 AWG); auxiliary voltage with plug-in screw terminal.

Human interface

Display elements

- Display:
 - 160 x 80 dot matrix LCD with white background, color switches to red in an alarm condition
- LED status display:
 - Operation: 1 x green
 - Fault indication: 1 x red

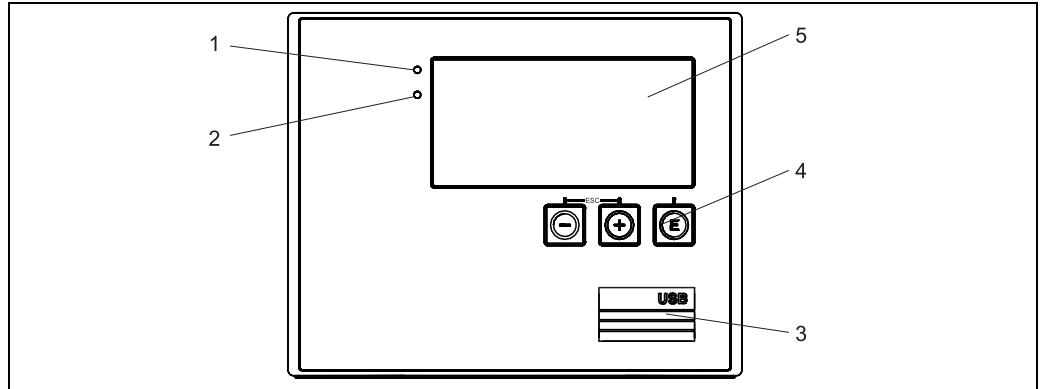

Display and operating elements of the BTU meter

- 1 LED green, "Operation"
- 2 LED red, "Fault indicator"
- 3 USB connection for configuration
- 4 Operating keys: -, +, E
- 5 160x80 DOT matrix display

Local operation

3 keys, "-", "+", "E".

Configuration interface

USB interface, front-panel, optional Ethernet interface: configuration via PC with PC operating software.

Data storage

Real time clock

- Drift: 15 min per year
- Power reserve: 1 week

Software

- **Field Data Manager software:** visualization software and database for analyzing and evaluating the measuring data and calculated values, as well as tamper-proof data storage

Certificates and approvals

Approval for custody transfer	As per MID (EN1434 water/liquids) and OIML R75
CE mark	The measuring system meets the legal requirements of the EU directives. Endress+Hauser confirms successful testing of the device by affixing to it the CE mark.
Other standards and guidelines	<ul style="list-style-type: none"> • IEC 60529: Degrees of protection provided by enclosures (IP code) • IEC 61010: Safety requirements for electrical equipment for measurement, control and laboratory use • IEC 61326: Electromagnetic compatibility (EMC requirements) • NAMUR NE21, NE43 Association for Standards for Control and Regulation in the Chemical Industry • IAWPS-IF 97 Internationally applicable and recognized calculation standard (since 1997) for steam and water. Issued by the International Association for the Properties of Water and Steam (IAPWS). • OIML R75 International construction and testing regulation for water energy managers by the Organisation Internationale de Métrologie Légale. • EN 1434 1, 2, 5 and 6 • EN ISO 5167 Measurement of fluid flow by means of pressure differential devices
Other approvals	CSA GP UL listed

Ordering information

Product structure

RH33	Compact Device BTU meter with display. 3 button operation, data storage (min/h/d/m/y, min/max, alarms), configuration socket for connection to PC (USB). 1 Analog/Puls input (Flow), 2 RTD/analog inputs (Temperature), 2 Digital input (reset counter), 2 Relay (limit monitoring, alarm). In a compact field housing.				
Approval:					
	AA	Non-hazardous area			
	CP	CSA GP			
Power Supply:					
	1	90-250VAC (AC: -15%/+10%,50/60 Hz)			
	2	20-35VDC; 20-28VAC (DC: -50%/+75%; AC: +/-50%,50/60 Hz)			
Medium:					
	A	Water			
	B	Glycol/Water + other fluids			
Ouput:					
	1	without			
	2	1x analog/puls (active), 2x open collector			
RH33-					← Order code (Part 1; 1 attribute per category must be selected.)
Additional selection (as option - no selection or multiple selection is possible)					
					Pre-installed Operation Language:
				BA	English
				BB	German
				BC	French
				BD	Spanish
				BE	Italian
				BF	Dutch
				BG	Portuguese
				BH	Polish
				BI	Russian
				BR	Czech
					Additional Sensorics:
				C1	mm, 2x Pt100, head: M20, process: G1/2" (+ paired via CvD-calibration)
				C2	mm, 2x Pt100, head: M20, process: 1/2"NPT (+ paired via CvD-calibration)
				C3	mm, 2x Pt100, head: NPT1/2, process: G1/2" (+ paired via CvD-calibration)
				C4	mm, 2x Pt100, head: NPT1/2, process: 1/2"NPT (+ paired via CvD-calibration)
					Communication:
				D1	Ethernet TCP/IP, Modbus
				D2	Modbus RTU RS485
				D3	M-Bus
					Application Package:
				E1	T-Sensor-Matching via CvD
				E2	Tariff function (2 counter)
				E3	Bidirectional measurement
				E4	DP-Flow calculation/compensation
					Calibration:
				F1	Works calib. certificate 5-point
				FY	Special version, TSP-no. to be specified
					Service:
				H1	Application specific pre-configured
				HY	Special version, TSP-no. to be specified
RH33-				+	← Order code (parts 1 + 2)

Accessories

- Software and communication** USB cable and FieldCare Device Setup calibration software incl. DTM library
- TXU10-AC
 - FXA291
- Visualization software with Field Data Manager database connection software
-

Overvoltage protection

Overvoltage protection for sensors and computer:

HAW569 surge arrester to screw into field housing, M20:

- Order code HAW569-A11A for non-hazardous locations
- Order code HAW569-B11A with approval for use in hazardous locations

HAW560/HAW562 surge arrester limiting high voltages on signal cables and components:

- Order No. 51003571: HAW560 module carrier for surge arrester, non-hazardous locations
- Order No. 51003574: HAW560Z module carrier for surge arrester, approval for use in hazardous locations
- Order No. 51003572: HAW562 surge arrester module, non-hazardous locations
- Order No. 51003575: HAW562Z surge arrester module, approval for use in hazardous locations

Documentation

- Operating Instructions for 'EngyCal® RH33 BTU Meter' (BA290R/09)
- Technical Information 'Overvoltage protection HAW561/561K, HAW560/560Z, HAW562/562Z, HAW565, HAW566' (TI093R/09)
- Technical Information 'Overvoltage protection HAW569/569Z' (TI103R/09)
- Brochure 'System components: Indicators with control unit for field and panel mounting, power supplies, barriers, transmitters, energy managers and surge arresters' (FA016K/09)

Deutschland

Endress+Hauser
Messtechnik
GmbH+Co. KG
Colmarer Straße 6
79576 Weil am Rhein

Fax 0800 EHFAXEN
Fax 0800 343 29 36
www.de.endress.com

Vertrieb
■ Beratung
■ Information
■ Auftrag
■ Bestellung

Tel. 0800 EHVTRIEB
Tel. 0800 348 37 87
info@de.endress.com

Service
■ Help-Desk
■ Feldservice
■ Ersatzteile/Reparatur
■ Kalibrierung

Tel. 0800 EHSERVICE
Tel. 0800 347 37 84
service@de.endress.com

Technische Büros
■ Hamburg
■ Berlin
■ Hannover
■ Ratingen
■ Frankfurt
■ Stuttgart
■ München

Österreich

Endress+Hauser
Ges.m.b.H.
Lehnergasse 4
1230 Wien
Tel. +43 1 880 56 0
Fax +43 1 880 56 335
info@at.endress.com
www.at.endress.com

Schweiz

Endress+Hauser
Metso AG
Kägenstrasse 2
4153 Reinach
Tel. +41 61 715 75 75
Fax +41 61 715 27 75
info@ch.endress.com
www.ch.endress.com

Endress+Hauser 
People for Process Automation