



Level



Pressure



Flow



Temperature



Liquid  
Analysis



Registration



Systems  
Components



Services



Solutions

## Technical Information

# Stamoclean CAT221

## Sampling unit

Self-cleaning backwash filter for inlet or outlet of wastewater treatment plants



### Application

The backwash filter is a special crossflow filter for water and wastewater.

It provides filtrate for continuous on-line monitoring. The filter's self-cleaning effect is achieved both by the flow at the wedge wire sieve and by backwashing with compressed air or rinse water.

Applications are:

- Municipal and industrial sewage treatment plants
  - Inlet
  - Outlet
- Process water with low solids content

### Your benefits

- High level of operational safety thanks to robust design
- Reduced operating costs thanks to automatic and chemical-free cleaning
- Efficient backwashing with compressed air or rinse water
- Filter inserts quick and simple to replace
- Long operating time
- Short response time of downstream measuring devices thanks to low dead volume
- Highly stable thanks to stainless steel sieve
- Very low power consumption (< 60 W)
- Simple to install as completely mounted and ready for connection and for wall mounting

## Function and system design

### Measuring principle

A sample flow of 1 to 2.5 m<sup>3</sup>/h (4.4 to 11 gal/min) is permanently conveyed through the backwash filter by means of a sampling pump or compressed air or rinse water. The filtrate passes through the wedge wire sieve and is then transported to the measuring device.

Clogging is minimized by the flow at the wedge wire sieve. Automatic backwashing results in a filter operating time of several weeks.

The automatic backwashing and a small compressor or compressed air resp. rinse water supply guarantee low-maintenance and low-energy operation.

### Measuring system

A complete measuring system comprises:

- a CAT221 filter system
- a collecting vessel
- a CA71xx analyser
- a sample pump or sample pressure line
- a compressor resp. compressed air supply

Optional: nitrate or SAC sensor (CNS70/CSS70) with flow assembly

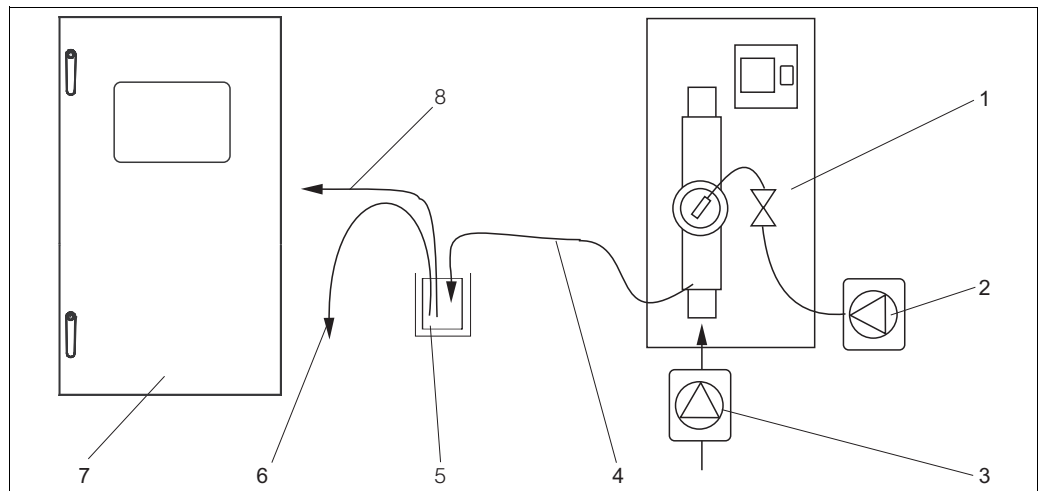

C07-CAT221xx-14-14-00-xx-001.EPS

#### Complete measuring system

- |   |                                       |   |                              |
|---|---------------------------------------|---|------------------------------|
| 1 | Backwash filter                       | 5 | Collecting vessel (optional) |
| 2 | Compressor or compressed air          | 6 | Overflow                     |
| 3 | Sampling pump or sample pressure line | 7 | Analyser                     |
| 4 | Sample outlet                         | 8 | Sample line to the analyser  |

## Power supply

### Electrical connection

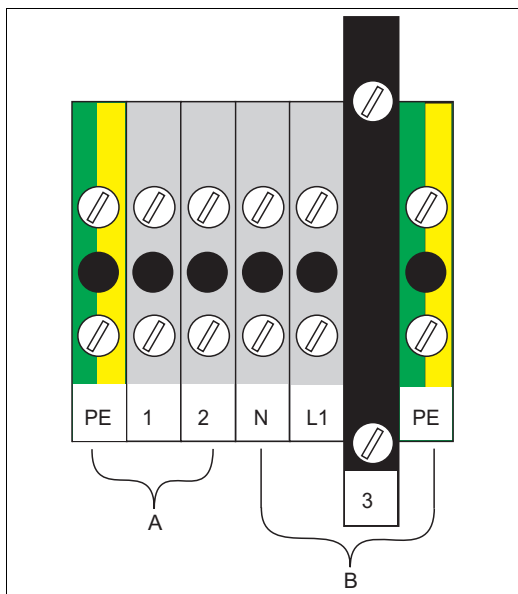

C07-CAT221-xx-04-14-00-xx-001.EPS

#### Terminals

- A Valve (configured at the factory)
- B Mains (to be connected by the customer)
- 3 Fuse

### Supply voltage

- Depending on version:
- 230 V AC, 50 Hz, approx. 60 VA
  - 115 V AC, 60 Hz
  - 24 V DC

### Fuses

- Depending on version:
- 230 V AC: 0.5 A, time-lag
  - 115 V AC: 1.0 A, time-lag
  - 24 V DC: 2.0 A, time-lag

## Performance characteristics

### Filtrate volume

minimum 10.0 l/h

### Separation performance

- Separation of particles, colloids and materials with high molecular weight Max. particle size depending on the used wedge wire sieve:
- 50 µm (for analysers)
  - 100 resp. 200 µm (for SAC or TOC)

### Life time of the wedge wire sieve

Approx. 1 to 2 years, even longer with appropriate care

### Cleaning interval

- Depending on application and soiling degree:
- inlet: approx. 2 to 4 weeks
  - outlet: approx. 2 to 6 months

### Chemical resistance

pH 3 to 14

### Rinse interval

1 to 90 minutes

### Rinse medium

2 to 4 bar (29 to 58 psi)

## Environment

**Ambient temperature** 0 to 50 °C (32 to 122 °F)

**Ingress protection** IP 54

## Process

**Sample temperature** 5 to 40 °C (41 to 104 °F)

**Sample overpressure** 0.2 to 4.0 bar (2.9 to 58 psi) at max. 40 °C (104 °F)

**Sampling rate** 1 to 2.5 m<sup>3</sup>/h

## Mechanical construction

### Design

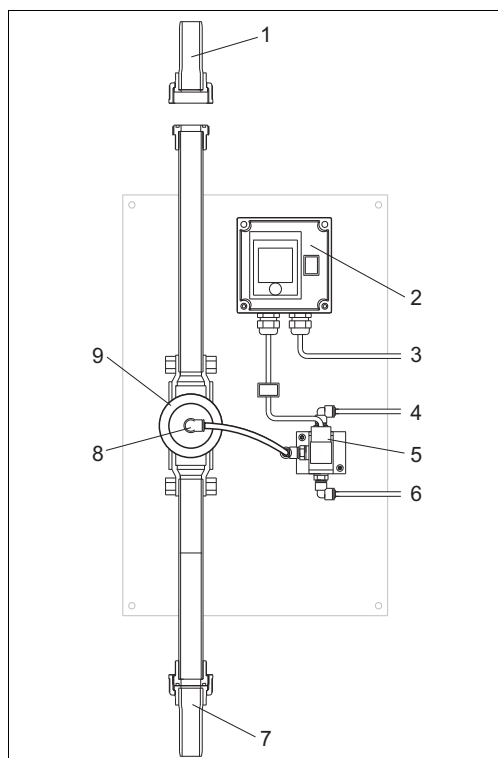

Outlet version

- 1 Delivery hose nozzle Ø30 mm (1.18 ")
- 2 Control unit
- 3 Mains
- 4 Rinse water resp. rinse air
- 5 Valve

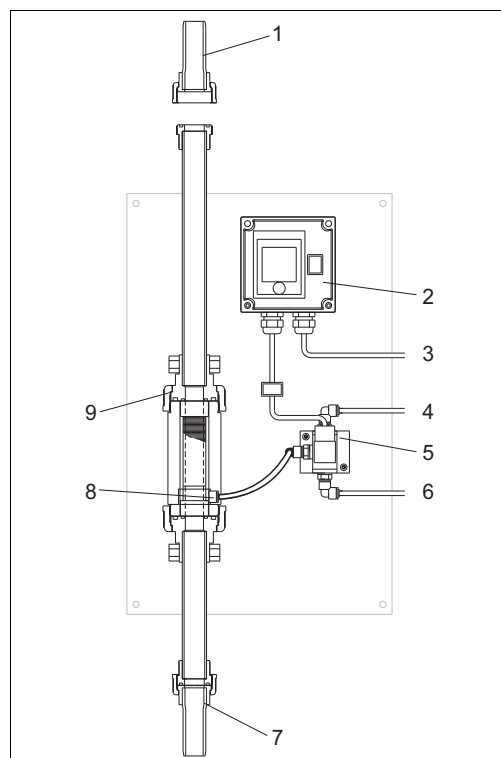

Inlet version

- 6 Filtrate (to the analyser)
- 7 Delivery hose nozzle Ø30 mm (1.18 ")
- 8 Hose adapter
- 9 Union nut

Dimensions

Open version, inlet

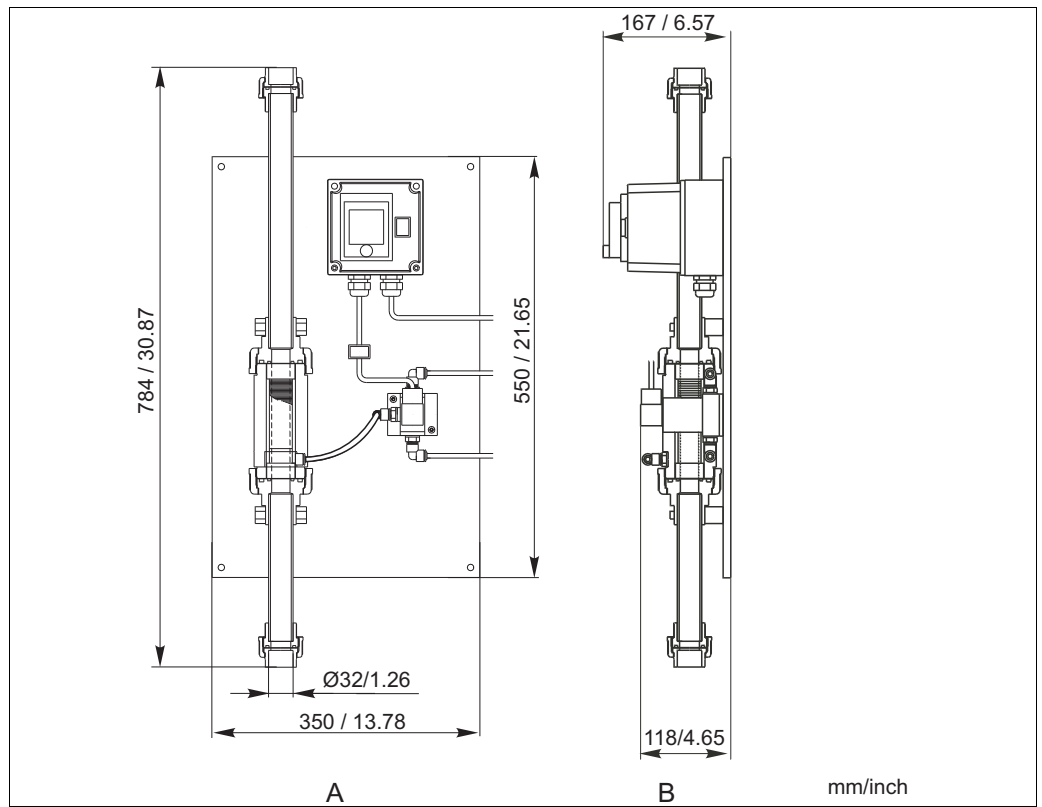

C07-CAT221xx-06-14-00-en-001.eps

Open inlet version

- A Front view
- B Side view

Open version, outlet

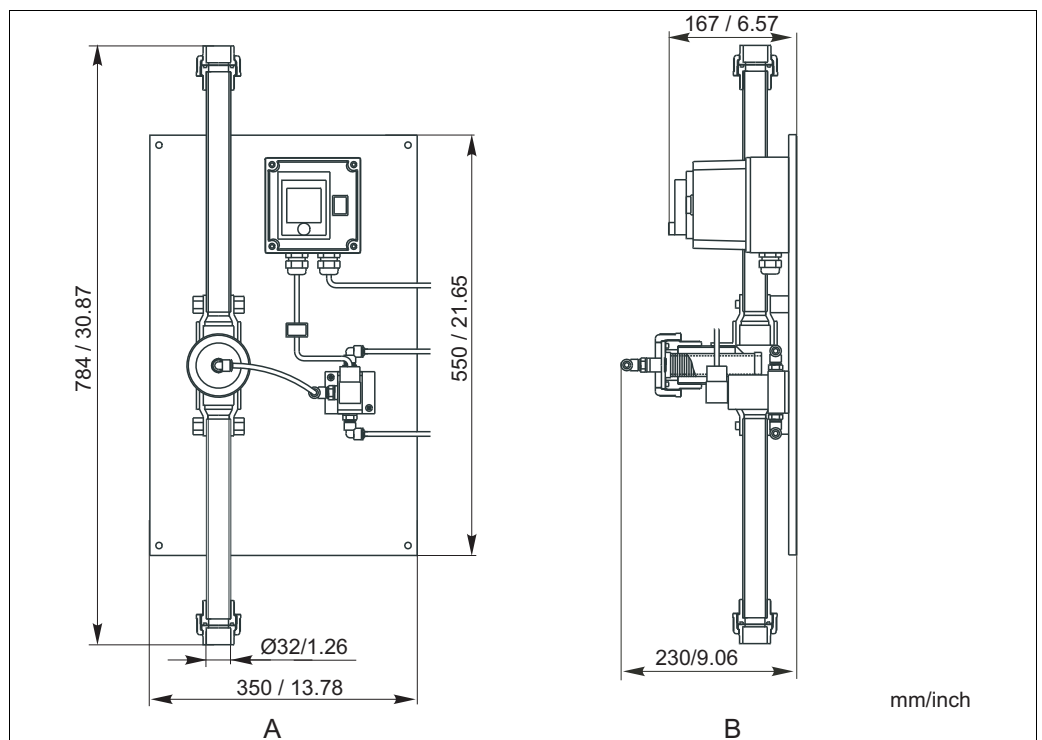

C07-CAT221xx-06-14-00-en-003.eps

Open outlet version

- A Front view
- B Side view

Housing version

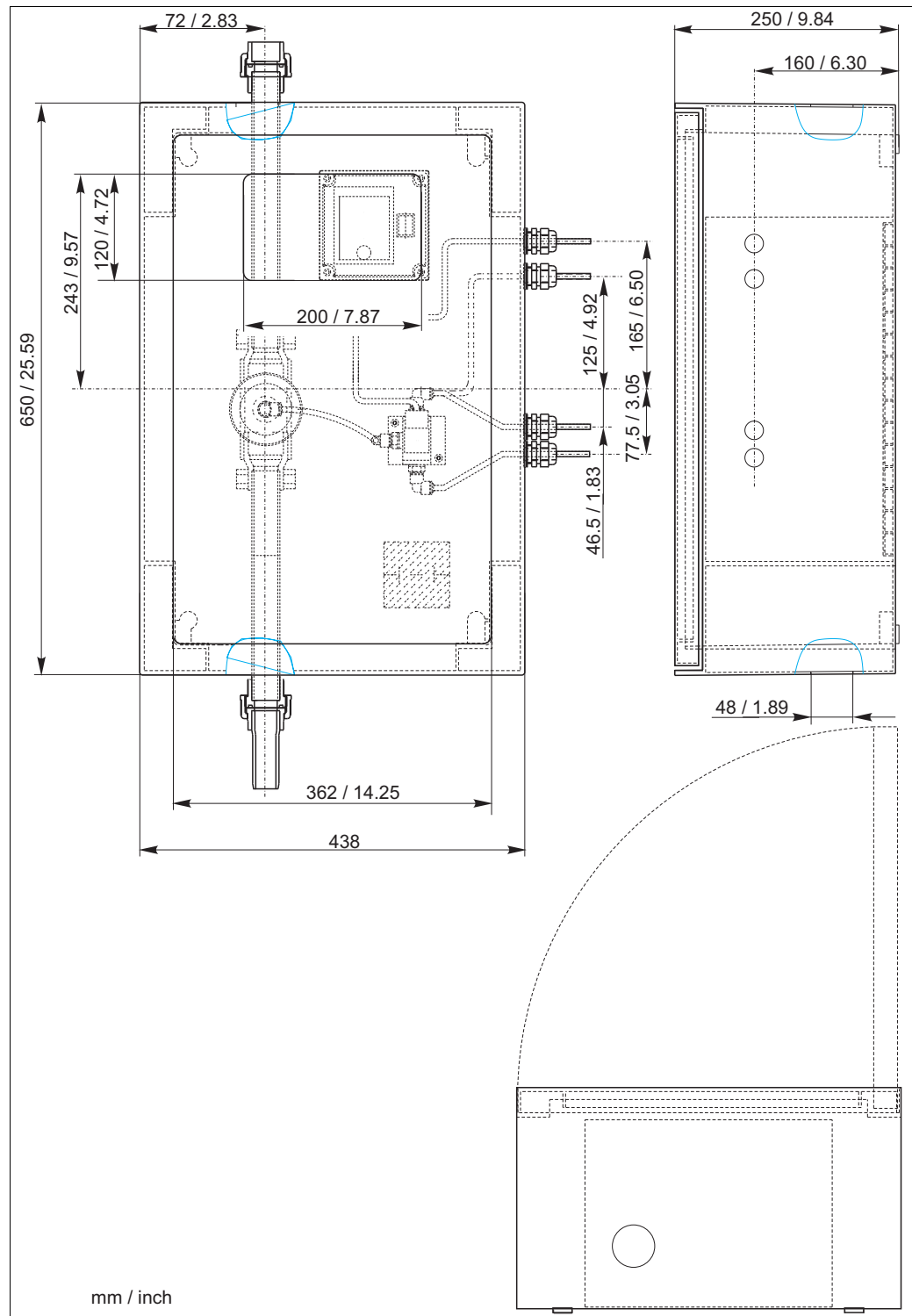

Housing version

C07-CAT221xx-00-14-00-en-002.eps

**Weight**

Open version:	7 kg (15.4 lb)
Housing version:	14 kg (30.9 lb)

**Materials**

Mounting plate, pipe:	PVC
Control unit housing:	polystyrene/polycarbonate
Wedge wire sieve:	SS 1.4435 (AISI 316L)
Housing:	GFK (glass-fibre reinforced plastic)

---

<b>Process connection</b>	<ul style="list-style-type: none"><li>■ Hose nozzle Ø30 mm (1.18") or</li><li>■ PVC adhesive threaded joint ID 32 mm (1.26")</li></ul>
<b>Filter elements</b>	<ul style="list-style-type: none"><li>■ 50 µm</li><li>■ 100 µm</li><li>■ 200 µm</li></ul>
<b>Rinse connection</b>	4/6 mm (0.16 / 0.24")
<b>Connection to analyser</b>	4/6 mm (0.16 / 0.24")
<b>Cable entry</b>	M20

---

## Human interface

### Display and operating elements

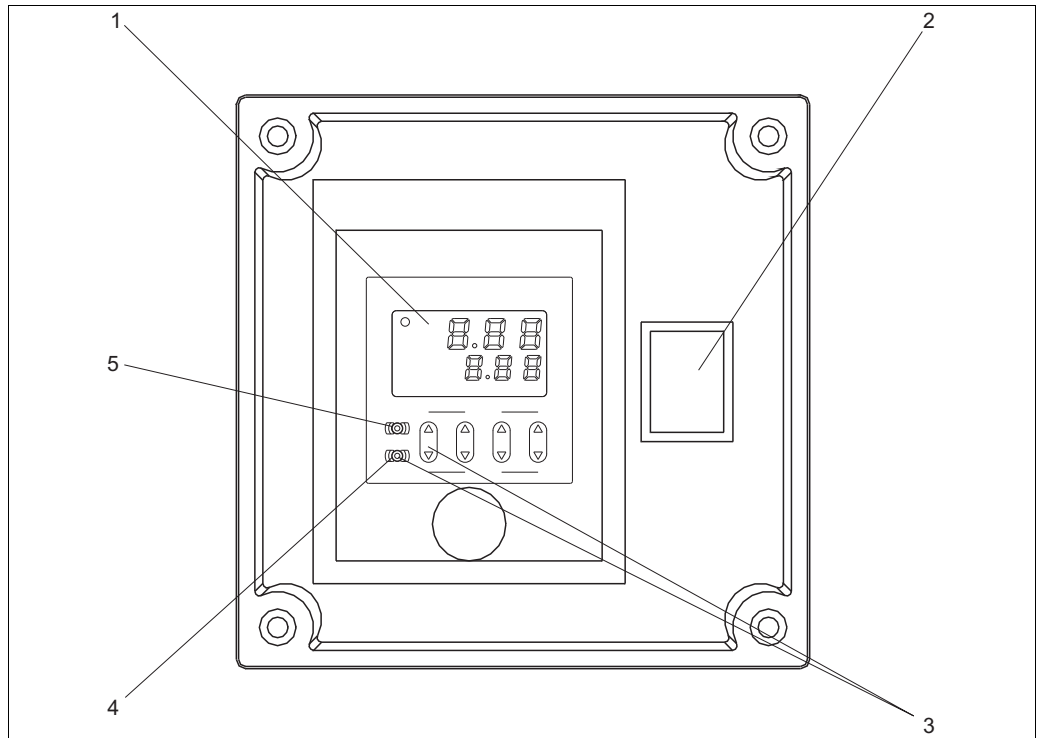

#### Display and operating elements

- 1 Display
- 2 Mains switch
- 3 LOCK function (by pressing both keys)
- 4 SET key
- 5 RESET key

a0014032

## Ordering information

### Product structure

Application	
A	Outlet
B	Inlet
Y	Special version acc. to customer's specification
Power supply	
0	230 V AC / 50 Hz
1	115 V AC / 60 Hz
8	24 V DC (not with housing version with heating)
Wedge wire sieve holes diameter	
A	50 µm
B	100 µm
C	200 µm
Version	
1	Open version
2	GFR housing, without heating
3	GFR housing, with heating (not with 24 V DC power supply)
9	Special version acc. to customer's specification
Additional equipment	
A	Quality certificate
CAT221-	<b>complete order code</b>

### Scope of delivery

The scope of delivery consists of:

- a sample preparation unit
- a connection hose to the analyzer, 2 m (6.56 ft), polyamide, I.D. 4 mm (0.16")
- a fitting 3.2 mm / 3.2 mm (0.13" / 0.13")
- a wall mounting set (with housing version only)
- Operating Instructions, English
- a quality certificate



## Accessories

---

### Installation accessories

- Three-way valve kit for backwash, 230 V;  
order no. 51516028
- Three-way valve kit for backwash, 115 V;  
order no. 51516029
- Three-way valve kit for backwash, 24 V DC;  
order no. 51516030
- Wedge wire sieves
  - Inlet
    - 50 µm; order no. 51516031
    - 100 µm; order no. 51516033
    - 200 µm; order no. 51516035
  - Outlet
    - 50 µm; order no. 51516032
    - 100 µm; order no. 51516034
    - 200 µm; order no. 51516036
- Hose adapter set
  - 1 Closing plug for quick snapping, 4 mm
  - 4 Thread connectors, angle, 4 mm
  - order no. 51516041
- Hose kit
  - ID4, AD6, PE
  - order no. 51516042
- Outlet bends
  - Bonded thread metric d32  
tube, PVC, d32x2.4  
angle d50, 90°  
T-piece, 90°, d50  
Check valve  
order no. 51516038
  - Bonded thread metric d32  
tube, PVC, d32x2.4  
angle d50, 90°  
order no. 51516039

---

### Sampling accessories

- Compressor for CAT221/CAT430/CPC300; order no. 51511868
- Sample pump on request

---

## Instruments International

Endress+Hauser  
Instruments International AG  
Kaegenstrasse 2  
4153 Reinach  
Switzerland

Tel.+41 61 715 81 00  
Fax+41 61 715 25 00  
[www.endress.com](http://www.endress.com)  
[info@ii.endress.com](mailto:info@ii.endress.com)

**Endress+Hauser**   
People for Process Automation