



Level



Pressure



Flow



Temperature



Liquid
Analysis



Registration



Systems
Components



Services



Solutions

Installation Instructions

Prothermo NMT539 Gas-tight feed through Temperature

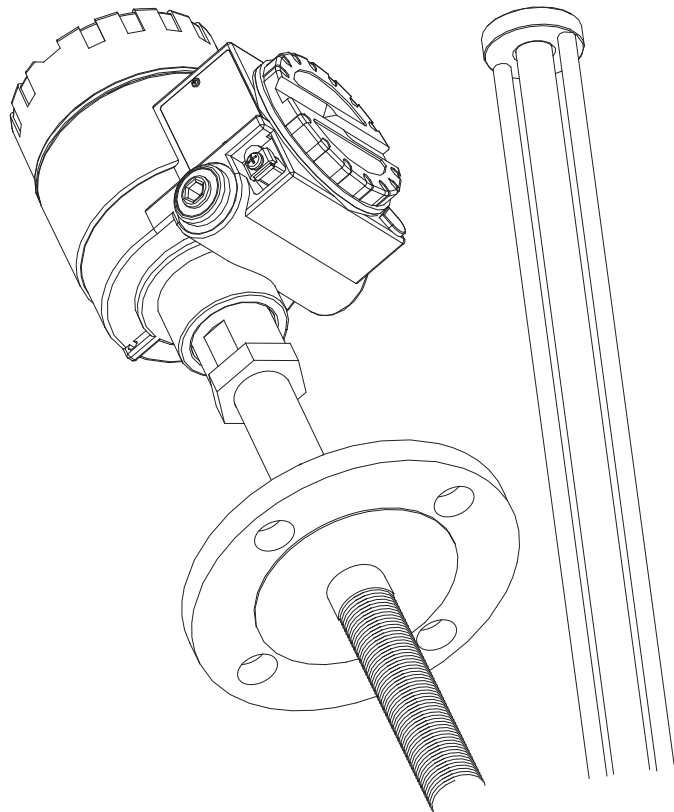

Table of Contents

1.	Installation	3
1.1	Design, Dimensions	3
1.2	Unpacking procedure	3
1.3	Flexible tube procedure	4
1.4	Mounting procedure	5

1 Installation

This manual describes only installation procedures specific to Prothermo NMT539 gas-tight feed through process connection mounting. Additional documents have been supplied together with your Prothermo NMT539. Refer to these additional documents for complete installation and commissioning descriptions.

- Installation Instructions BA1025G
- Operating Instructions and Description of Instrument Function BA1026G
- Safety Instructions XA00002G

1.1 Design, Dimensions

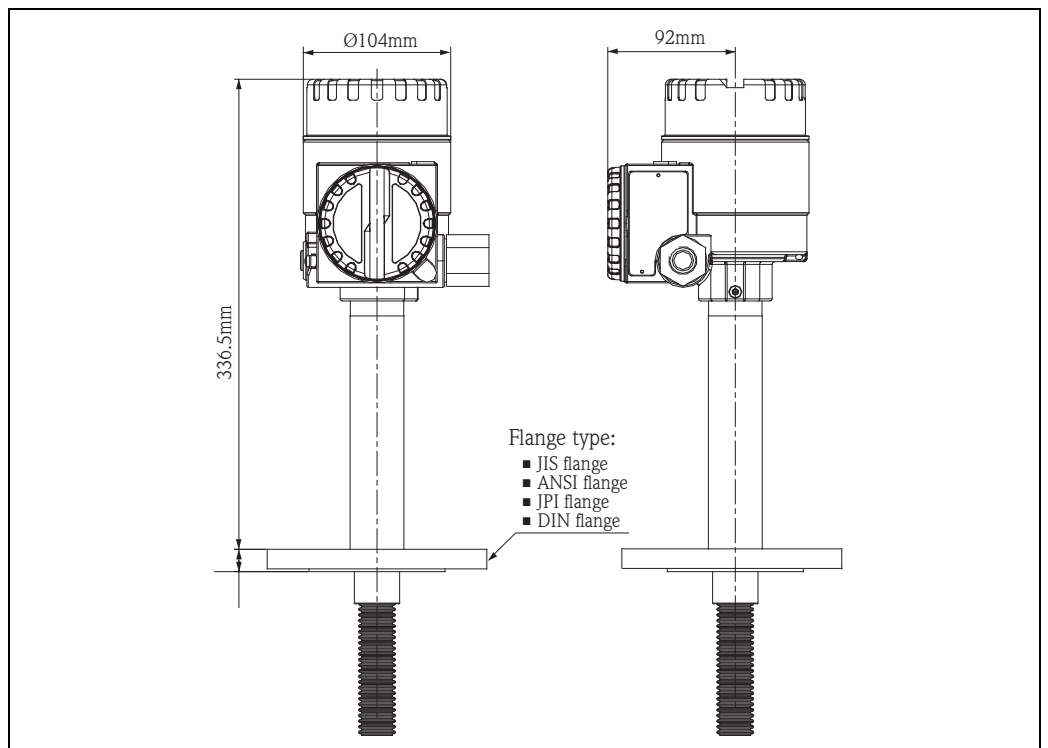

1.2 Unpacking procedure



Note!

Do not bend or twist the flexible tube when unpacking Prothermo NMT539. Bending or twisting may damage the tube and/or enclosed temperature sensor elements.

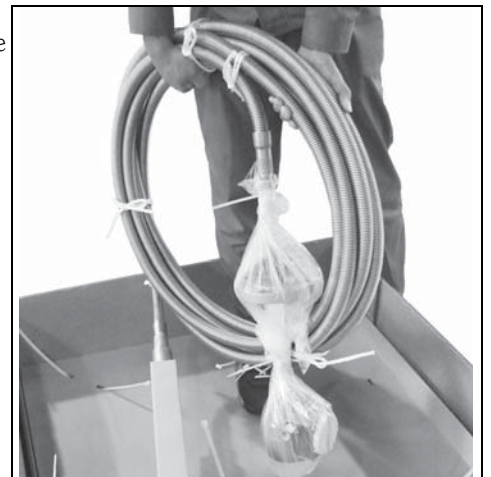

1.3 Flexible tube procedure

Note!



Do not try to lift the sensor by a single point of the flexible tube. Damage may occur.

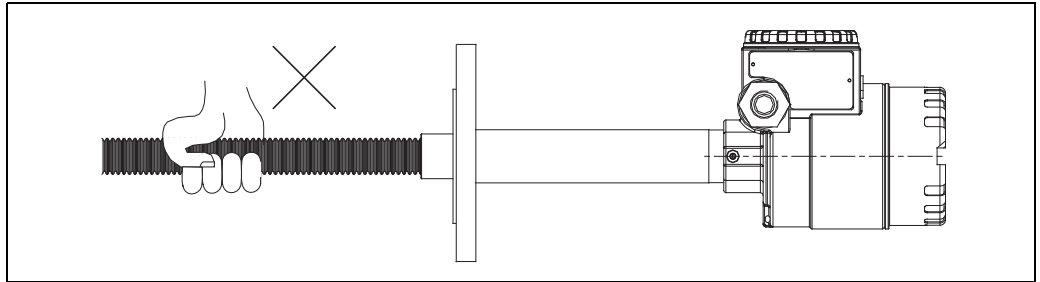

When coiling the flexible tube, please keep the diameter at least 1 meter (39.37") or more. When bending the flexible tube, the radius of curvature must be at least 500mm (19.96") at any location.

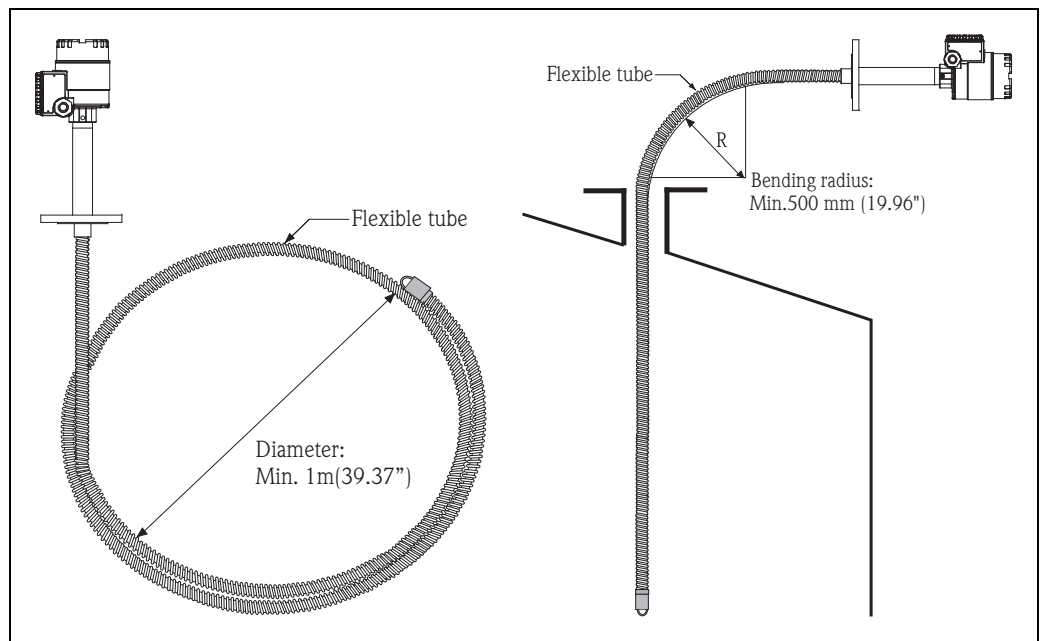

Note!



If a flexible tube is bent with a radius of curvature of less than 500mm (19.69"), the flexible tube or the measuring element may be seriously damaged or broken.

1.4 Mounting procedure

Unlike NMT539 with height-adjuster, the Gas-tight feed through process connection is welded and not height-adjustable. The figure below illustrates mounting on the tank process connection. Refer to the additional documents supplied together with Prothermo NMT539 for complete installation and commissioning descriptions.

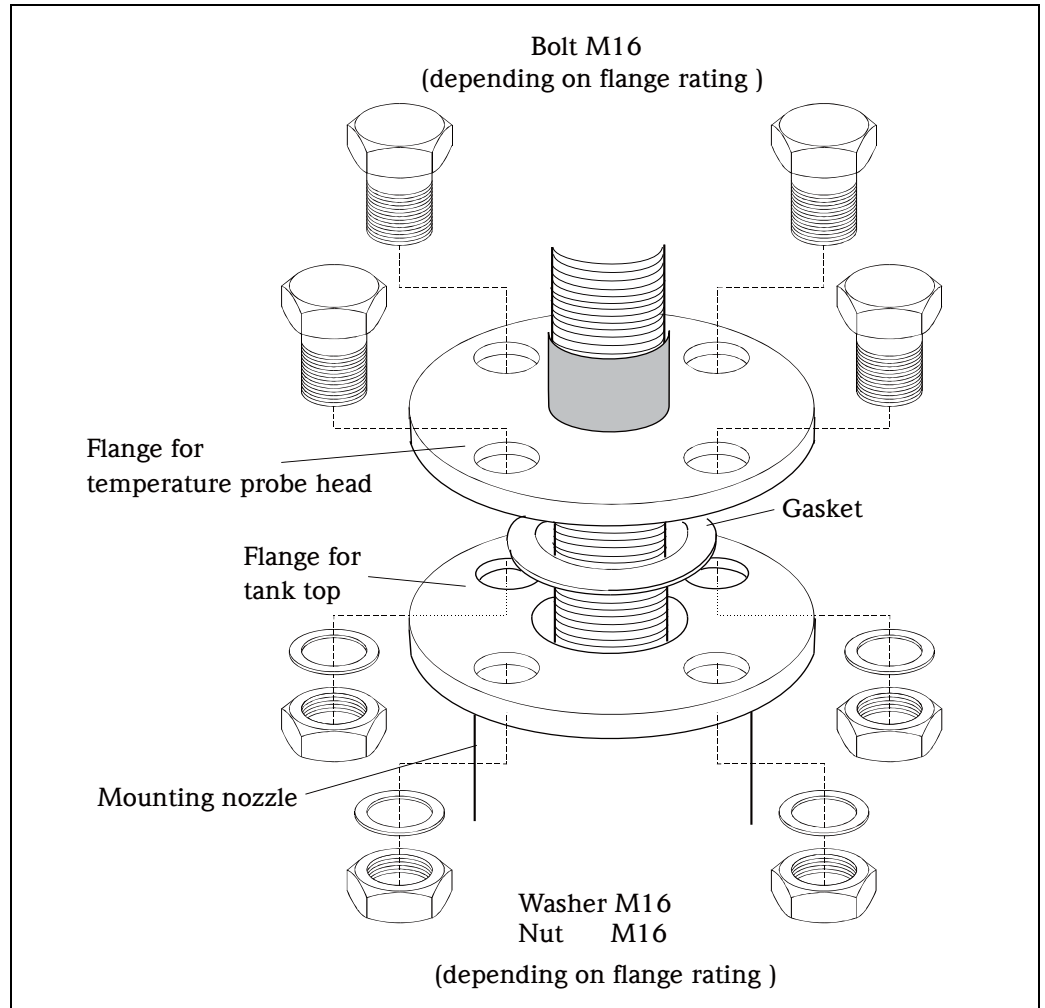

Endress + Hauser Japan Co., Ltd.
Product Center Yamanashi
862-1 Mitsukunugi Sakaigawa-cho
Fuefuki-shi Yamanashi,
406-0846 Japan

Phone: ++81 55 266 4964
Fax: ++81 55 266 4969

Endress+Hauser 
People for Process Automation