



Level



Pressure



Flow



Temperature



Liquid  
Analysis



Registration



Systems  
Components



Services



Solutions

Operating Instructions

# Liquistation CSF48

Automatic sampler for liquid media

## Operation & settings

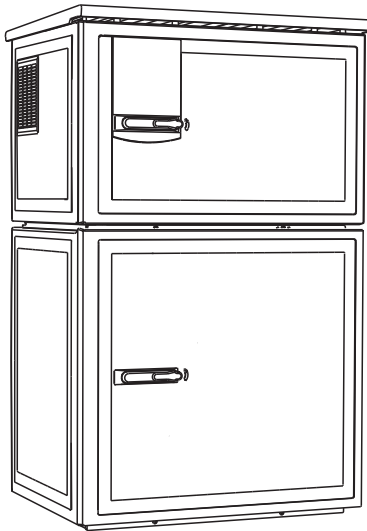

BA00464C/07/EN/16.12  
71185371

Valid as of:  
Softwareversion 01.03.00

# Operation concept

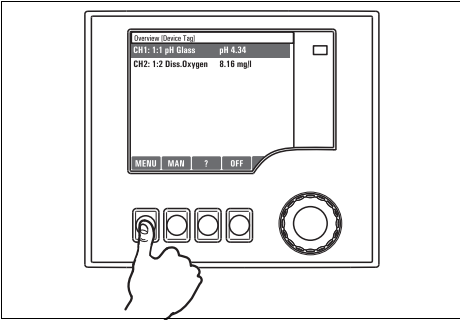

Fig. 1: Pressing the soft key: selecting the menu directly

a0013353-en

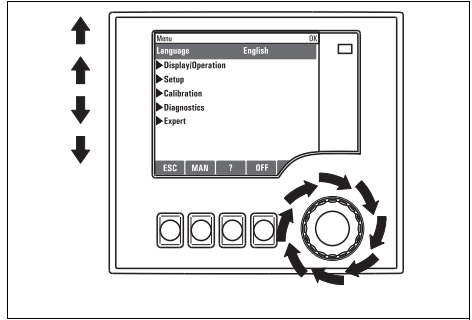

Fig. 2: Turning the navigator: moving the cursor in the menu

a0013354-en

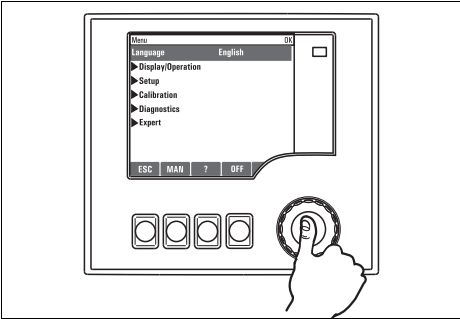

Fig. 3: Pressing the navigator: launching a function

a0013355-en

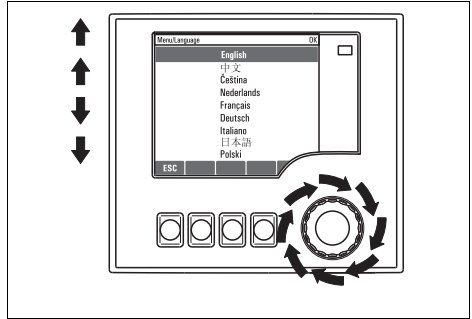

Fig. 4: Turning the navigator: selecting a value (e.g. from a list)

a0013356-en

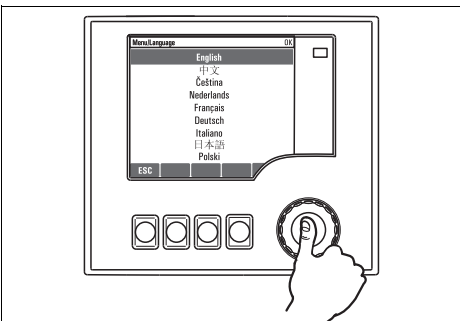

Fig. 5: Pressing the navigator: accepting the new value

a0013357-en

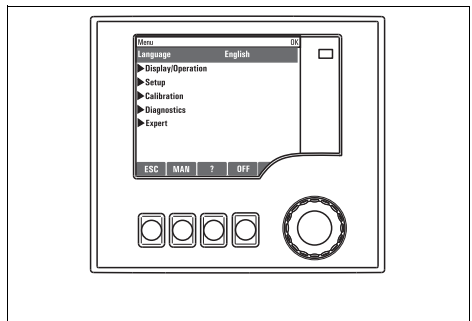



Fig. 6: Result: new setting is accepted

a0013358-en

## Locking/unlocking operating keys

Press the navigator for longer than 2 s. A context menu appears which you can use to lock or unlock the operating keys. The  symbol appears in the softkey display if the keys are locked.

---

# Table of contents

<b>1</b>	<b>About this manual</b>	<b>5</b>	<b>8</b>	<b>Information on sensors with the Memosens protocol.</b>	<b>97</b>
<b>2</b>	<b>General settings</b>	<b>6</b>	<b>9</b>	<b>Inputs: General</b>	<b>98</b>
2.1	Basic settings	6	9.1	Configuration	98
2.2	Date and time	7	9.2	Frequently occurring functions	98
2.3	Automatic hold (optional)	8	<b>10</b>	<b>Inputs: pH/ORP</b>	<b>104</b>
2.4	Logbooks	8	10.1	Basic settings	104
2.5	Configuring the sampling depending on the device version	13	10.2	Extended setup	105
2.6	Extended setup	18	<b>11</b>	<b>Inputs: Conductivity</b>	<b>113</b>
<b>3</b>	<b>Inputs</b>	<b>24</b>	11.1	Basic settings	113
3.1	Binary inputs	24	11.2	Extended setup	119
3.2	Current inputs	28	<b>12</b>	<b>Inputs: Oxygen</b>	<b>123</b>
<b>4</b>	<b>Programming</b>	<b>31</b>	12.1	Basic settings	123
4.1	Overview of the possible program types	32	12.2	Extended setup	124
4.2	Program type: Basic	35	<b>13</b>	<b>Inputs: Chlorine</b>	<b>133</b>
4.3	Program types: Standard and Advanced	50	13.1	Basic settings	133
4.4	Executing the program	74	13.2	Extended setup	134
<b>5</b>	<b>Outputs</b>	<b>75</b>	<b>14</b>	<b>Inputs: Turbidity and solids</b>	<b>141</b>
5.1	Binary outputs	75	14.1	Basic settings	141
5.2	Current outputs (optional)	78	14.2	Extended setup	142
5.3	<b>Alarm relays</b>	80	<b>15</b>	<b>Inputs: SAC</b>	<b>146</b>
5.4	HART	83	15.1	Basic settings	146
<b>6</b>	<b>Additional functions</b>	<b>84</b>	15.2	Extended setup	147
6.1	Limit switch	84	<b>16</b>	<b>Inputs: Nitrate</b>	<b>151</b>
6.2	Cleaning programs (only for version with sensors with the Memosens protocol)	87	16.1	Basic settings	151
6.3	Mathematical functions	88	16.2	Extended setup	152
<b>7</b>	<b>Communication</b>	<b>93</b>	<b>17</b>	<b>Inputs: ISE</b>	<b>156</b>
7.1	Web server	93	17.1	Basic settings	156
7.2	Service interface	94	17.2	Extended setup	157
7.3	Fieldbuses	96	17.3	Electrode slot menus	158
			17.4	Limits operating hours	165

---

<b>18</b>	<b>Inputs: Interface</b>	<b>166</b>
18.1	Basic settings	166
18.2	Manual hold	166
18.3	Tank configuration	167
18.4	Sensor signal	168
18.5	Extended setup	169
	<b>Index</b>	<b>172</b>

# 1 About this manual

This manual gives a detailed account of all the configuration options **in the "Setup" menu**.

A description of the following menus is provided here:

- Inputs
  - Input configuration
  - Split into separate sections based on the different types of sensor that can be connected
  -  Some submenus are identical for all sensor types.  
These submenus are repeated in each input-specific section to make sure you can find the information you need quickly and easily.
- Outputs
  - Output configuration
  - Split into separate sections based on the different output types
- Sampling programs
  - Creating sampling programs
  - Configuring different types of programs
- Additional functions
  - Settings for the alarm sensor
  - Cleaning program configuration
- Data management
  - Firmware updates
  - Saving and loading configurations

**This manual does not include the following:**

- Setup/General settings
  - Operating Instructions BA00443C "Commissioning"
- Display/Operation
  - Operating Instructions BA00443C "Commissioning"
- Calibration
  - Operating Instructions BA00467C "Calibration"
- Diagnostics
  - Operating Instructions BA00463C "Maintenance & diagnostics"
- Expert
  - Internal Service Manual

## 2 General settings

 Many settings are not visible when a program is running.  
If a program is running, stop the program before making any settings!

### 2.1 Basic settings

Path: Menu/Setup/General settings

Function	Options	Info
Device tag	Customized text, 32 characters	Select any name for your controller. Use the TAG name for example.
Temperature unit	Options <ul style="list-style-type: none"> <li>■ °C</li> <li>■ °F</li> <li>■ K</li> </ul> <b>Factory setting</b> °C	
Current output range	Options <ul style="list-style-type: none"> <li>■ 0 to 20 mA</li> <li>■ 4 to 20 mA</li> </ul> <b>Factory setting</b> 4 to 20 mA	In accordance with Namur NE43, the linear range is from 3.8 to 20.5 mA (Current output range="4 to 20 mA") or from 0 to 20.5 mA (Current output range="0 to 20 mA"). If the range is exceeded or undershot, the current value stops at the range limit and a diagnostics message (460 or 461) is output. You <b>must</b> select the "4 to 20 mA" range for HART communication.
Error current	0.0 to 23.0 mA <b>Factory setting</b> 21.5 mA	The function meets NAMUR NE43. Set the current value that should be output at the current outputs in the event of an error.
<p> The value for "Error current" should be outside the measuring range. If you decided that your Current output range = "0 to 20 mA", you should set an error current between 20.1 and 23 mA. If the Current output range = "4 to 20 mA" you could also define a value &lt; 4 mA as the error current. The device allows an error current within the measuring range. In such instances pay attention to possible affects this may have on your process.</p>		
Alarm delay	0 to 9999 s <b>Factory setting</b> 0 s	The system only displays the errors that are present longer than the set delay time. This makes it possible to suppress error messages that only occur briefly and are caused by normal process-specific fluctuations.

## 2.2 Date and time

Path: Menu/Setup/General settings/Date/Time

Function	Options	Info
Set date	Depends on the format	Editing mode: DD (day): 01 to 31 MM (month): 01 to 12 YYYY (year): 1970 to 2106
Set time	Depends on the format	Editing mode: hh (hour): 00 to 23 / 0 am to 12 pm mm (minutes): 00 to 59 ss (seconds): 00 to 59
▶ Extended setup		
Date format	Options <ul style="list-style-type: none"> <li>■ DD.MM.YYYY</li> <li>■ YYYY-MM-DD</li> <li>■ MM-DD-YYYY</li> </ul> <b>Factory setting</b> DD.MM.YYYY	Decide which date format you want to use.
Time format	Options <ul style="list-style-type: none"> <li>■ HH:MM am (12h)</li> <li>■ HH:MM (24h)</li> <li>■ HH:MM:SS (24h)</li> </ul> <b>Factory setting</b> HH:MM:SS (24h)	Decide whether you want to use the 12-hour or 24-hour clock. Seconds can also be displayed with the latter version.
Time zone	Options <ul style="list-style-type: none"> <li>■ None</li> <li>■ Choice of 35 time zones</li> </ul> <b>Factory setting</b> None	If no time zone is selected, then Greenwich Mean Time is used (London).
DST	Options <ul style="list-style-type: none"> <li>■ Off</li> <li>■ Europe</li> <li>■ USA</li> <li>■ Manual</li> </ul> <b>Factory setting</b> Off	The controller adapts the summertime/normal time changeover automatically if you choose European or American daylight saving time. Manual means that you can specify the start and end of daylight saving time yourself. Here, two additional submenus are displayed in which you specify the changeover date and time.

## 2.3 Automatic hold (optional)

Path: Menu/Setup/General settings/Automatic hold

Function	Options	Info
▶ Device specific hold		
Setup menu	Options	Decide whether a hold should be output at the current output when the particular menu is opened.
Diagnostics menu	<ul style="list-style-type: none"> <li>■ Disabled</li> <li>■ Enabled</li> </ul> <b>Factory setting</b> Disabled	
Calibration menu	<b>Factory setting</b> Enabled	
Hold delay	0 to 600 s <b>Factory setting</b> 0 s	The hold is maintained for the duration of the delay time when you switch to the measuring mode.

## 2.4 Logbooks

Logbooks record the following events:

- Calibration/adjustment events
- Operation events
- Diagnostic events
- Programming events

Here you define how the logbooks should store the data.

In addition, you are also able to define individual data logbooks. Assign the logbook name and select the measured value to be recorded. You can configure the recording rate (Scan time) individually for every data logbook.

More information on the logbooks is provided in BA00463C "Maintenance & diagnostics", "Diagnostics menu" section.

Path: Menu/Setup/General settings/Logbooks

Function	Options	Info
Logbook ident	Customized text	Part of the file name when exporting a logbook
Event logbook	Options <ul style="list-style-type: none"> <li>■ Off</li> <li>■ Ring buffer</li> <li>■ Fill up buffer</li> </ul> <b>Factory setting</b> Ring buffer	All diagnostic messages are recorded  <b>Ring buffer</b> If the memory is full, the latest entry automatically overwrites the oldest entry.  <b>Fill up buffer</b> If the memory is 80% full, the device displays a diagnostic message.  If the memory is full, there is an overflow, i.e. no new values can be saved. The controller displays a corresponding diagnostic message. The memory then has to be cleared manually.



## Path: Menu/Setup/General settings/Logbooks

Function	Options	Info
Logbook program	Options <ul style="list-style-type: none"> <li>■ Off</li> <li>■ Ring buffer</li> <li>■ Fill up buffer</li> </ul> <b>Factory setting</b> Ring buffer	All program messages are recorded <b>Ring buffer</b> If the memory is full, the latest entry automatically overwrites the oldest entry. <b>Fill up buffer</b> If the memory is 80% full, the device displays a diagnostic message. If the memory is full, there is an overflow, i.e. no new values can be saved. The controller displays a corresponding diagnostic message. The memory then has to be cleared manually.
▶ Overflow warnings <i>Event logbook="Fill up buffer"</i>		
Calibration logbook	Options <ul style="list-style-type: none"> <li>■ Off</li> <li>■ On</li> </ul> <b>Factory setting</b> Off	Decide whether you want to receive a diagnostic message from the controller in the event of memory overrun of the logbook in question.
Diagnostic logbook		
Configuration logbook		
Overflow warnings <i>Logbook program="Fill up buffer"</i>	Options <ul style="list-style-type: none"> <li>■ Off</li> <li>■ On</li> </ul> <b>Factory setting</b> Off	If the fill-up buffer overruns, you can decide whether you want to receive a diagnostic message from the controller or not for each individual logbook.
▶ Data logbooks		
▶ New		You can create a maximum of 8 data logbooks.
Logbook name	Customized text, 20 characters	
Source of data	Options <ul style="list-style-type: none"> <li>■ None</li> <li>■ Binary input 1</li> <li>■ Binary input 2</li> <li>■ Analog input 1</li> <li>■ Analog input 2</li> <li>■ Temperature</li> </ul> <b>Factory setting</b> None	Select the input that should be the data source of the logbook entries.
Measured value	Options <ul style="list-style-type: none"> <li>■ Depends on Source of data</li> </ul> <b>Factory setting</b> None	You can record different measured values depending on the source of data.
Scan time	00:00:01 to 01:00:00 <b>Factory setting</b> 00:01:00	Minimum interval between two entries Format: HH:MM:SS

**Path: Menu/Setup/General settings/Logbooks**

Function	Options	Info
Data logbook	Options <ul style="list-style-type: none"> <li>■ Off</li> <li>■ Ring buffer</li> <li>■ Fill up buffer</li> </ul> <b>Factory setting</b> Off	<b>Ring buffer</b> If the memory is full, the latest entry automatically overwrites the oldest entry. <b>Fill up buffer</b> If the memory is 80% full, the device displays a diagnostic message. If the memory is full, there is an overflow, i.e. no new values can be saved. The controller displays a corresponding diagnostic message. The memory then has to be cleared manually.
Overflow warning <i>Data logbook= "Fill up buffer"</i>	Options <ul style="list-style-type: none"> <li>■ Off</li> <li>■ On</li> </ul> <b>Factory setting</b> Off	If the fill-up buffer overruns, you can decide whether you want to receive a diagnostic message from the controller or not for each individual logbook.
▷ Add another logbook	Action	<i>Only if you want to create another data logbook immediately.</i> You add a new data logbook at a later data using ▶ New.
▷ Finished	Action	This allows you to exit the menu ▶ New.
▷ Start/stop simultaneously	Action	Appears if you have created more than one data logbook. With one click, you can start or stop recording for all the data logbooks.
▶ "Logbook name"		The name of this submenu is based on the name of the logbook and only appears once you have created a logbook.
 This menu appears several times if you have several data logbooks.		
Source of data	Read only	This is for information purposes only. If you want to record another value, delete this logbook and create a new data logbook.
Measured value		
Log time left <i>Data logbook= "Fill up buffer"</i>	Read only	Displays the days, hours and minutes remaining until the logbook is full.
Log size <i>Data logbook= "Ring buffer"</i>	Read only	Displays the number of entries remaining until the logbook is full.
Logbook name	Customized text, 20 characters	You can change the name here again.
Scan time	00:00:01 to 01:00:00 <b>Factory setting</b> 00:01:00	As above Minimum interval between two entries Format: HH:MM:SS

## Path: Menu/Setup/General settings/Logbooks

Function	Options	Info
Data logbook	Options <ul style="list-style-type: none"> <li>■ Off</li> <li>■ Ring buffer</li> <li>■ Fill up buffer</li> </ul> <b>Factory setting</b> Off	<b>Ring buffer</b> If the memory is full, the latest entry automatically overwrites the oldest entry. <b>Fill up buffer</b> If the memory is 80% full, the device displays a diagnostic message. If the memory is full, there is an overflow, i.e. no new values can be saved. The controller displays a corresponding diagnostic message. The memory then has to be cleared manually.
▶ Line plotter		Menu to define the graphic display
Axes	Options <ul style="list-style-type: none"> <li>■ Off</li> <li>■ On</li> </ul> <b>Factory setting</b> On	Should the axes (x, y) be displayed (On) or not (Off)?
Orientation	Options <ul style="list-style-type: none"> <li>■ Horizontal</li> <li>■ Vertical</li> </ul> <b>Factory setting</b> Horizontal	You can choose whether the value curves should be displayed from left to right ("Horizontal") or from top to bottom ("Vertical"). If you want to display two data logbooks simultaneously, make sure that both logbooks have the same settings here.
X-Description	Options <ul style="list-style-type: none"> <li>■ Off</li> <li>■ On</li> </ul> <b>Factory setting</b> On	Decide whether a description should be displayed for the axes and whether grids should be shown. In addition, you can also decide whether a pitch should be displayed.
Y-Description		
Grids		
Pitches		
X Pitch/Grid distance	10 to 50%	Specify the pitch.
Y Pitch/Grid distance	<b>Factory setting</b> 10 %	
▷ Remove	Action	This action removes the data logbook. Any data that have not been saved are lost.

### **Example for setting up a new data logbook**

1. Menu/Setup/General settings/Logbooks/Data logbooks/New:
  - a. Logbook name: Assign a name, e.g. "01".
  - b. Source of data: Select a data source, e.g. the sensor connected to binary input 1.
  - c. Measured value: Select the measured value that you want to record.
  - d. Scan time: Specify the interval between two logbook entries.
  - e. Data logbook: Activate the logbook. Specify the type of memory, "Ring buffer" or "Fill up buffer".
2. ../Finished: Execute this action.  
—> Your new logbook now appears in the list of data logbooks.
3. Select the data logbook with the name "01".
4. If you selected "Fill up buffer", you can also decide whether you want to receive a diagnostic message in the event of memory overrun.
5. Depending on the type of memory selected, you receive information about the memory space (for "Ring buffer") or the time remaining until memory overrun (for "Fill up buffer").
6. Define the graphic display mode in the "Line plotter" submenu.

## 2.5 Configuring the sampling depending on the device version



The list of functions displayed depends on the device version selected.

Functions marked <sup>1)</sup> are available in device versions with a vacuum pump.

Functions marked <sup>2)</sup> are available in device versions with a peristaltic pump.

Functions marked <sup>3)</sup> are available in device versions with a distribution arm drive.

Functions marked <sup>4)</sup> are available in device versions with a sampling assembly.

**Path: Menu/Setup/General settings**

Function	Options	Info
▶ Sampling		
Number of bottles	Choice of all possible bottle combinations	The bottle configuration you ordered is preset in the device.
Bottle volume	0 to 100000 ml <b>Factory setting</b> Depends on the bottle configuration	
Distribution reference <sup>3)</sup>	Options <ul style="list-style-type: none"> <li>■ Pre sampling</li> <li>■ Pre bottle change</li> <li>■ Pre program start</li> </ul> <b>Factory setting</b> Pre sampling	The distribution arm goes through a reference point depending on the option selected. <b>Pre sampling:</b> This means that the distribution arm performs a reference test before each individual sampling. <b>Pre bottle change:</b> This means that the distribution arm performs a reference test in every subprogram. <b>Pre program start:</b> This means that a single reference test is performed before the program starts.
Power failure	Options <ul style="list-style-type: none"> <li>■ Resume program</li> <li>■ Stop program</li> </ul> <b>Factory setting</b> Stop program	Decide how the sampler should react when it is energized after a power failure. <b>Resume program:</b> <ul style="list-style-type: none"> <li>■ Time and flow-paced The program calculates the omitted samples and enters them in the logbook as failed. When the program is restarted, it continues where it was interrupted.</li> <li>■ Flow-paced No samples are entered in the logbook during the power failure. When the program is restarted, it continues where it was interrupted.</li> </ul>
Sample retries <sup>1), 2), 3)</sup>	0 to 3 <b>Factory setting</b> 0	If sampling is started and no sample is drawn in, sampling can be repeated up to 3 times.
Sampling delay	0 to 99 s <b>Factory setting</b> 0 s	The start of the sampling cycle can be delayed by up to 99 s. The binary output is switched without any delay.

## Path: Menu/Setup/General settings

Function	Options	Info
Liquid detection <sup>1)</sup>	Options <ul style="list-style-type: none"> <li>■ Automatic</li> <li>■ Semi automatic</li> </ul> <b>Factory setting</b> Automatic	If "Semiautomatic" is selected, the purge times and intake times can be defined separately.
Dosing volume <sup>1), 4)</sup>	<sup>1)</sup> 20 to 350 ml <b>Factory setting</b> 200 ml  <sup>4)</sup> Options <ul style="list-style-type: none"> <li>■ 10 ml</li> <li>■ 30 ml</li> <li>■ 50 ml</li> </ul> <b>Factory setting</b> 10 ml	<sup>1)</sup> Adjust the dosing tube in the dosing chamber to change the dosing volume. The level in the bottle is calculated using the set dosing volume.  <sup>4)</sup> Selection of the sample volume for the CSA420 assembly
Conductive sensor <sup>1)</sup>	Options <ul style="list-style-type: none"> <li>■ Low sensitivity</li> <li>■ Medium sensitivity</li> <li>■ High sensitivity</li> </ul> <b>Factory setting</b> Medium sensitivity	The switching behavior can be set with the liquid detection function. Use the high sensitivity setting if the sample has a low conductivity, for example.
Dosing chamber <sup>1)</sup>	Options <ul style="list-style-type: none"> <li>■ Dose without pressure (A)</li> <li>■ Dose with pressure (B)</li> </ul> <b>Factory setting</b> Dose without pressure (A)	Dosing with pressure e.g. in conditions with low suction heights and slight counterpressure or low volumes.
Liquid detection <sup>2)</sup>	Options <ul style="list-style-type: none"> <li>■ Automatic</li> <li>■ Semi automatic</li> <li>■ Off</li> </ul> <b>Factory setting</b> Automatic	If "Semiautomatic" is selected, the purge times and intake times can be defined separately. <b>Off:</b> The definition of the purge times and intake times is completely time-controlled. <b>Automatic:</b> The last intake time determined is the new purge time. <b>Semi automatic:</b> If the suction heights tend to vary greatly.
Rinse cycles <sup>2)</sup>	0 to 3 <b>Factory setting</b> 0	The suction line is rinsed with the sample up to 3 times.
Safety interlock <sup>2)</sup> (optional)	Options <ul style="list-style-type: none"> <li>■ Off</li> <li>■ On</li> </ul> <b>Factory setting</b> Off	If the peristaltic pump is opened, the safety interlock stops all the functions.
Sampling time <sup>4)</sup>	5 to 20 s <b>Factory setting</b> 5 s	Enter the time during which the injected piston is located in the sample.

## Path: Menu/Setup/General settings

Function	Options	Info
Dosing time <sup>4)</sup>	5 to 100 s <b>Factory setting</b> 5 s	Enter the time until the sample is dosed.
Dosing mode <sup>4)</sup>	Options <ul style="list-style-type: none"> <li>■ Dose without pressure (A)</li> <li>■ Dose with pressure (B)</li> </ul> <b>Factory setting</b> Dose without pressure (A)	<b>Dose with pressure (B):</b> The sample is conveyed with pressure from the sample compartment of the assembly into the sampler. This function is only possible if the compressed air valve is connected to binary output 1.
Time after sampling <sup>4)</sup> (is only displayed if more than one bottle is present)	1 to 100 s <b>Factory setting</b> 5 s	The time the tap waits in the bottle position when dosing has finished
Sample pre shots <sup>4)</sup> (is only displayed if more than one bottle is present)	0 to 10 <b>Factory setting</b> 0	Enter the sample rinsing cycles with the current sample.
Assembly cleaning <sup>4)</sup> (is only displayed if more than one bottle is present)	Options <ul style="list-style-type: none"> <li>■ Off</li> <li>■ with air</li> <li>■ with water</li> </ul> <b>Factory setting</b> Off	Select the purge medium: air connected to binary output 1 or water connected to binary output 2. If "Off" is selected, the binary outputs can be used as in the standard version.
▶ Diagnostics settings		
▶ Sensor fouling <sup>1)</sup>		
Warning	0 to 10 <b>Factory setting</b> 7	Indicates maintenance work must be performed on the conductivity sensors. If there is conductive fouling between the conductivity 1 and conductivity 2 electrode, a diagnostic message is displayed when this level of fouling is reached.
Alarm	7 to 10 <b>Factory setting</b> 10	If there is conductive fouling between the conductivity 1 and conductivity 2 electrode, a diagnostic message is displayed when this level of fouling is reached.
▶ Pump tube life <sup>2)</sup>		
Control	Options <ul style="list-style-type: none"> <li>■ Off</li> <li>■ On</li> </ul> <b>Factory setting</b> On	Indicates the pump hose has to be exchanged.
Warning	10 to 50 h <b>Factory setting</b> 30 h	When the tube has been in operation for this length of time, a diagnostic message is displayed to indicate that the tube should be replaced in time.
Alarm	30 to 200 h <b>Factory setting</b> 50 h	

## Path: Menu/Setup/General settings

Function	Options	Info
Totalizer	00-00:00 to 49710-06:28 <b>Factory setting</b> 00-00:00	Operating time of the current pump hose in days, hours and minutes
▷ Reset	Action	The tube life counter is reset to 0:00 h.
▶ Process sealing <sup>4)</sup>		
Control	Options <input type="checkbox"/> Off <input type="checkbox"/> On <b>Factory setting</b> On	Monitoring of the process seal
Warning	100 to 80000 <b>Factory setting</b> 50000	Enter the number of samples until a warning is issued.
Alarm	50000 to 1000000 <b>Factory setting</b> 80000	Enter the number of samples until an alarm is issued.
Totalizer	Read only	Settings for the sample totalizer
▷ Reset	Action	
▶ Armature lock position <sup>4)</sup>		Assembly is set to the lock position.
▶ Sample temperature (optional)		
Temp. control	Options <input type="checkbox"/> Off <input type="checkbox"/> On <b>Factory setting</b> On	Switch the temperature control of the sample compartment on or off here.
Economy operation	Options <input type="checkbox"/> Off <input type="checkbox"/> On <b>Factory setting</b> Off	On: Cooling is not enabled until the program takes the first sample. After this, the cooling regulator runs until the program is restarted.
Sample temperature	2 to 20 °C <b>Factory setting</b> 4 °C	Set the sample compartment temperature.
Cooling control	Options <input type="checkbox"/> Standard operation <input type="checkbox"/> Quick cool down <b>Factory setting</b> Standard operation	The temperature regulator is switched off for a certain time if quick cool-down is selected.



## Path: Menu/Setup/General settings

Function	Options	Info
▶ Defrosting		
 The automatic defrosting function is preset at the factory. The following changes may only be made by experts.		
Mode	Options <ul style="list-style-type: none"> <li>■ Off</li> <li>■ On</li> </ul> <b>Factory setting</b> On	Configuration of the automatic defrosting function
Interval	Options <ul style="list-style-type: none"> <li>■ Hourly</li> <li>■ Daily</li> <li>■ Weekly</li> <li>■ Monthly</li> </ul> <b>Factory setting</b> Hourly	Select the defrosting interval
Time	00-01:00 to 00-23:59  <b>Factory setting</b> 00-04:00	
Duration	00:01 to 02:00  <b>Factory setting</b> 00:05	

## 2.6 Extended setup

### 2.6.1 Diagnostics settings

The list of diagnostic messages displayed depends on the path selected. There are device-specific messages, and messages that depend on what sensor is connected.

**Path:** ... /Extended setup/Diagnostics settings/Diag. behavior (optional)

Function	Options	Info
List of diagnostic messages		Select the message to be changed. Only then can you make the settings for this message.
Diag. code	Read only	
Diagnostic message	Options <ul style="list-style-type: none"> <li>■ On</li> <li>■ Off</li> </ul> <b>Factory setting</b> Depends on the message	You can deactivate or reactivate a diagnostic message here.  Deactivating means: <ul style="list-style-type: none"> <li>■ No error message in the measuring mode</li> <li>■ No error current at the current output</li> </ul>
Error current	Options <ul style="list-style-type: none"> <li>■ On</li> <li>■ Off</li> </ul> <b>Factory setting</b> Depends on the message	Decide whether an error current should be output at the current output if the diagnostic message display is activated.   If general device errors occur, the error current is output at all the current outputs. In the case of channel-specific errors, the error current is only output at the specific current output.
Status signal	Options <ul style="list-style-type: none"> <li>■ Maintenance (M)</li> <li>■ Out of specification (S)</li> <li>■ Function check (C)</li> <li>■ Failure (F)</li> </ul> <b>Factory setting</b> Depends on the message	The messages are divided into different error categories in accordance with NAMUR NE 107. → BA00463C "Maintenance & diagnostics"
Diag. output	Options <ul style="list-style-type: none"> <li>■ None</li> <li>■ Alarm relay</li> <li>■ Relay 1 to n (depends on the device version)</li> </ul> <b>Factory setting</b> None	You can use this function to select a relay output and/or binary output to which the diagnostic message should be assigned.  For sensors with the Memosens protocol: You first have to configure a relay output before being able to assign the message to an output (Menu/Setup/Outputs, assign "Diagnostics" function and set Operating mode to "as assigned").
Cleaning program(optional)	Options <ul style="list-style-type: none"> <li>■ None</li> <li>■ Cleaning 1</li> <li>■ Cleaning 2</li> <li>■ Cleaning 3</li> <li>■ Cleaning 4</li> </ul> <b>Factory setting</b> None	Decide whether the diagnostic message should trigger a cleaning program. You can define the cleaning programs under: Menu/Setup/Additional functions/Cleaning.
Detail information	Read only	Here you can find more information on the diagnostic message and instructions on how to resolve the problem.

## 2.6.2 HART bus address

If Multidrop is active (Bus address > 0), the current at current output 1 is fixed at 4 mA. Here, it does not matter what function has been assigned to the output (measured value/controller etc.). Current simulation is no longer possible.

**Path: Menu/Setup/General settings/Extended setup/HART**

Function	Options	Info
Bus address	0 to 63 <b>Factory setting</b> 0	You can change the device address to integrate several HART devices in a network (Multidrop mode).

 If you reset the device to the factory settings (Diagnostics/Systemtest/Reset/Factory default), the bus address is not reset. Your setting is retained.

## 2.6.3 PROFIBUS DP

**Path: Menu/Setup/General settings/Extended setup/Profibus**

Function	Options	Info
Enable	Options <ul style="list-style-type: none"> <li>■ Off</li> <li>■ On</li> </ul> <b>Factory setting</b> Off	You can switch off PROFIBUS communication at this point. The software can then only be accessed via local operation.
Termination	Read only	If the device is the last in the bus, you can terminate via the hardware. → BA00443C, "Wiring" section
Bus address	1 to 125	If you have addressed the bus via hardware (DIP switches on the module, → BA00443C), you can only read the address here. If an invalid address is set via the hardware, you have to assign a valid address for your device either here or via the bus.
Ident number	Options <ul style="list-style-type: none"> <li>■ Automatic</li> <li>■ PA-Profile 3.02 (9760)</li> <li>■ Liquiline CM44x (155D)</li> <li>■ Liquistation CSFxx (155C)</li> <li>■ Liquiport CSPxx (155E)</li> </ul> <b>Factory setting</b> Automatic	

## 2.6.4 Modbus

Path: Menu/Setup/General settings/Extended setup/Modbus

Function	Options	Info
Enable	Options <ul style="list-style-type: none"> <li>■ Off</li> <li>■ On</li> </ul> <b>Factory setting</b> Off	You can switch off Modbus communication at this point. The software can then only be accessed via local operation.
Termination	Read only	If the device is the last in the bus, you can terminate via the hardware. → BA00443C, "Wiring" section
Settings		
Transmission Mode	Options <ul style="list-style-type: none"> <li>■ TCP</li> <li>■ RTU</li> <li>■ ASCII</li> </ul>	The transmission mode is displayed depending on the version ordered. In the case of RS485 transmission, you can choose between "RTU" and "ASCII".
Watchdog	0 to 999 s <b>Factory setting</b> 5 s	If no data transmission takes place for longer than the time set, this is an indicator that communication has been interrupted. After this time, input values received via the Modbus are considered to be invalid.

## 2.6.5 Ethernet

Path: Menu/Setup/General settings/Extended setup/Ethernet

Function	Options	Info
Enable	Options <ul style="list-style-type: none"> <li>■ Off</li> <li>■ On</li> </ul> <b>Factory setting</b> Off	You can switch ethernet communication on and off at this point.
Settings		
Webserver	Options <ul style="list-style-type: none"> <li>■ Off</li> <li>■ On</li> </ul> <b>Factory setting</b> On	You can switch the internal web server on and off at this point. <b>Off:</b> It is then not possible to access the device via the web browser.
DHCP	Options <ul style="list-style-type: none"> <li>■ Off</li> <li>■ On</li> </ul> <b>Factory setting</b> Off	The Dynamic Host Configuration Protocol (DHCP) makes it possible to assign the network configuration to clients via a server. With DHCP, it is possible to automatically integrate the device into an existing network without the need for manual configuration. Normally, the client need only be configured for automatic retrieval of the IP addresses. During startup, the IP address, the netmask and the gateway are retrieved from a DHCP server.

**Path: Menu/Setup/General settings/Extended setup/Ethernet**

Function	Options	Info
IP-Address	xxx.xxx.xxx.xxx	An IP address is an address in computer networks which are based on the Internet protocol (IP).
Netmask	xxx.xxx.xxx.xxx	On the basis of the IP address of a device, the netmask specifies which IP addresses this device searches for in its own network and which addresses it could access in other networks via a router. It therefore divides the IP address into a network part (network prefix) and a device part. The network part must be identical for all devices in the individual network, and the device part must be different for every device within the network.
Gateway	x.x.x.x	A gateway (protocol converter) enables communication between networks that are based on completely different protocols.
MAC-Address	Read only	The MAC address (Media Access Control address) is the hardware address of every individual network adapter which is used to uniquely identify the device in a computer network.
Modbus TCP port	Read only	The Transmission Control Protocol (TCP) is an arrangement (protocol) as to how data should be exchanged between computers. A port is a part of an address which assigns data segments to a network protocol.
Webserver TCP port	Read only	

## 2.6.6 Data management

### Firmware update

Please contact your local sales office for information on firmware updates available for your controller and its compatibility with earlier versions.

Your **current firmware version** can be found at: Menu/Diagnostics/System information/Software version.



First save your current setup on an SD card since a firmware update overwrites your settings with the factory settings. After updating the firmware, you can restore your setup by uploading it from the SD card.

To install a firmware update, you must have the update available on an SD card.

1. Insert the SD card into the controller card reader.
2. Go to: Menu/Setup/General settings/Extended setup/Data management/Firmware update.  
→ The update files on the SD card are displayed.
3. Select the desired update and select yes when the following question is displayed: The current firmware will be overwritten. After this the device will reboot. Do you want to proceed?  
→ The firmware is loaded and the device is then started with the new firmware.

## **Saving the setup**

Saving the setup gives you the following advantages:

- Quick and easy to restore a setup following a firmware update
- Copying settings for other devices
- Quick and easy switching between various setups, e.g. for different user groups or for recurring sensor type change
- Restoring a tried-and-tested setup, e.g. if you have changed a lot of settings and no longer know what the original settings were

1. Insert the SD card into the controller card reader.
2. Go to: Menu/Setup/General settings/Extended setup/Data management/Save setup.
3. Assign a file name (Name).
4. Then select "Save".
5. If you have already assigned the file name, you will be asked whether you want to overwrite the existing setup.  
Select "OK" to confirm, or cancel the action and give the file a new name.

→ Your setup is stored on the SD card and you can upload it quickly to the device at a later date.

## **Loading the setup**

You can load a setup you have saved quickly and easily:

1. Insert the SD card into the controller card reader.
2. Go to: Menu/Setup/General settings/Extended setup/Data management/Load setup.  
→ A list of all the setups on the SD card is displayed.
3. Select the desired setup.  
The device then displays the following message: The current parameters will be overwritten and the device will reboot. Do you want to proceed?
4. Select "OK" to confirm or cancel the action.

→ The desired setup is restored after restarting the device.

## **Exporting the setup**

Exporting the setup gives you the following advantages

- Export in xml format
- Import the data e.g. into MS Excel (drag&drop the xml file in an open Excel window)

1. Insert the SD card into the controller card reader.
2. Go to: Menu/Setup/General settings/Extended setup/Data management/Export setup.
3. Assign a file name (Name).
4. Then select "Export".
5. If you have already assigned the file name, you will be asked whether you want to overwrite the existing setup.  
Select "OK" to confirm, or cancel the action and give the file a new name.

→ Your setup is saved on the SD card.

## Activation code

You require activation codes for:

- Additional functions, e.g. fieldbus communication
- Software upgrades

Enter the activation code:

- ▶ Menu/Setup/General settings/Extended setup/Data management/Activation code.
- ▶ Confirm your entry. Your new hardware or software function is then activated and can be configured.

-  If activation codes are available for your device, these codes are provided on the inner nameplate. The corresponding device functions are activated at the factory. You only require the codes if servicing the device.

**The table below tells you what functions an activation code enables:**

Function	Activation code beginning with
Second Memosens input	062...
Two current outputs (BASE-E module only)	081...
HART	0B1...
PROFIBUS DP	0B3...
Modbus TCP	0B4...
Modbus RS485	0B5...

### 3 Inputs

Liquistation CSF48 has 2 binary inputs and 2 current inputs as standard. All inputs are galvanically isolated from one another.

#### 3.1 Binary inputs

The binary inputs are used to control the sampler using external signals. With the CSF48, the auxiliary voltage of 24 V DC from the terminal block in the connection compartment of the sampler can be used for floating contacts (see BA00443C "Commissioning").

**Path: Menu/Setup/Inputs**

Function	Options	Info
▶ Binary input S:x		
Mode	Options <ul style="list-style-type: none"> <li>■ Off</li> <li>■ On</li> </ul> <b>Factory setting</b> Off	Switches the function on or off
Input mode	Options <ul style="list-style-type: none"> <li>■ Flow rate</li> <li>■ Rainfall</li> <li>■ External event</li> </ul> <b>Factory setting</b> Flow rate	<ul style="list-style-type: none"> <li>■ Pulse input for connected flowmeters or rain gages</li> <li>■ Control of sampling functions via external signals</li> </ul>
If Input mode <b>Flow rate</b> is selected:		
Signal slope	Options <ul style="list-style-type: none"> <li>■ Low-High</li> <li>■ High-Low</li> </ul> <b>Factory setting</b> Low-High	Preselect the level change of the signal.
Unit	Options <ul style="list-style-type: none"> <li>■ m<sup>3</sup></li> <li>■ l</li> <li>■ cf</li> <li>■ gal</li> </ul> <b>Factory setting</b> m <sup>3</sup>	Select the unit.
Meas. value format	<b>Factory setting</b> #.#	Specify the number of decimal places for the flow.
1 Impulse =	0 to 1000 m <sup>3</sup> <b>Factory setting</b> 10 m <sup>3</sup>	Definition of the pulse value, limits are calculated depending on the unit



## Path: Menu/Setup/Inputs

Function	Options	Info
▶ Unit of totalized flow		
Current totalized flow	--	The totalized flow values are displayed.
Reset totalizer	Options <ul style="list-style-type: none"> <li>■ Manual</li> <li>■ Automatic</li> <li>■ At program start</li> </ul> <b>Factory setting</b> Manual	<b>Manual:</b> Reset the counter manually. <b>Automatic:</b> The counter is reset automatically at intervals. <b>At program start:</b> The counter is reset at program start.
If counter reset <b>Manual</b> is selected:		
▷ Reset totalized flow	Action	The totalized flow currently calculated is set to zero when the counter is reset.
If counter reset <b>Automatic</b> is selected:		
Interval	Options <ul style="list-style-type: none"> <li>■ Daily</li> <li>■ Weekly</li> <li>■ Monthly</li> </ul> <b>Factory setting</b> Daily	<b>Daily:</b> If a daily interval is selected, set the Time in the menu item that follows. <b>Weekly:</b> If a weekly interval is selected, set the Day of week and the Time in the menu items that follow. <b>Monthly:</b> If a monthly interval is selected, set the Day of month and the Time in the menu items that follow.
Time	00:00:00 to 23:59:59 HH:MM:SS <b>Factory setting</b> 12:00:00 HH:MM:SS	
If Input mode <b>Rainfall</b> is selected:		
Signal slope	Options <ul style="list-style-type: none"> <li>■ Low-High</li> <li>■ High-Low</li> </ul> <b>Factory setting</b> Low-High	Preselect the level change of the signal.
Unit	Options <ul style="list-style-type: none"> <li>■ mm</li> <li>■ inch</li> </ul> <b>Factory setting</b> mm	Select the unit.
Meas. value format	<b>Factory setting</b> #.#	Specify the number of decimal places.
1 Impulse =	0.00 to 5.00 mm <b>Factory setting</b> 1.0 mm	Definition of the pulse value, limits are calculated depending on the unit. The correct switch value is provided in the Operating Instructions of your rain gage.

**Path: Menu/Setup/Inputs**

Function	Options	Info
Intensity	Options <ul style="list-style-type: none"> <li>■ mm/min</li> <li>■ mm/h</li> <li>■ mm/d</li> </ul> <b>Factory setting</b> mm/min	Select the intensity per minute, hour or day according to your requirements.
▶ Totalized rainfall		
Totalized rainfall	---	The totalized rainfall is displayed.
Reset totalizer	Options <ul style="list-style-type: none"> <li>■ Manual</li> <li>■ Automatic</li> <li>■ At program start</li> </ul> <b>Factory setting</b> Manual	<b>Manual:</b> Reset the counter manually.  <b>Automatic:</b> The counter is reset automatically at intervals.  <b>At program start:</b> The counter is reset at program start.
If counter reset <b>Manual</b> is selected:		
▶ Reset totalized rainfall	Action	The totalized rainfall currently calculated is set to zero when the meter is reset manually.
If counter reset <b>Automatic</b> is selected:		
Interval	Options <ul style="list-style-type: none"> <li>■ Daily</li> <li>■ Weekly</li> <li>■ Monthly</li> </ul> <b>Factory setting</b> Daily	<b>Daily:</b> If a daily interval is selected, set the Time in the menu item that follows.  <b>Weekly:</b> If a weekly interval is selected, set the Day of week and the Time in the menu items that follow.  <b>Monthly:</b> If a monthly interval is selected, set the Day of month and the Time in the menu items that follow.
Time	00:00:00 to 23:59:59 HH:MM:SS  <b>Factory setting</b> 12:00:00 HH:MM:SS	

## Path: Menu/Setup/Inputs

Function	Options	Info
If Input mode <b>External event</b> is selected:		
Operation	Options <ul style="list-style-type: none"> <li>■ No operation</li> <li>■ Start sampling</li> <li>■ Program start</li> <li>■ Program stop</li> <li>■ Program duration</li> <li>■ Program pause</li> <li>■ Partprogram activation</li> <li>■ Change bottle</li> <li>■ Bottle synchronization</li> <li>■ External hold</li> </ul> <b>Factory setting</b> No operation	<b>No operation:</b> No action is executed.  <b>Start sampling:</b> A pulse triggers sampling.  <b>Program start:</b> A pulse starts a program.  <b>Program stop:</b> A pulse stops the program running.  <b>Program duration:</b> A program is active as long as the input signal is present. The signal is a level signal, i.e. the action takes effect as long as the level is present. The level that triggers the action is configured in the Signal slope menu item that follows.  <b>Program pause:</b> The input signal stops the program running. The programs continue running when the signal disappears. The signal is a level signal, i.e. the action takes effect as long as the level is present. The level that triggers the action is configured in the Signal slope menu item that follows.  <b>Partprogram activation:</b> A pulse triggers a subprogram.  <b>Change bottle:</b> A pulse triggers a changeover to the next bottle.  <b>Bottle synchronization:</b> A pulse triggers a changeover to the set bottle position. —> Then select the bottle position (depends on the bottle configuration).  <b>External hold:</b> The input signal triggers an external hold. The signal is a level signal, i.e. the action takes effect as long as the level is present. The level that triggers the action is configured in the Signal slope menu item that follows.
Signal slope	Options <ul style="list-style-type: none"> <li>■ Low-High</li> <li>■ High-Low</li> </ul> <b>Factory setting</b> Low-High	Preselect the level change of the signal. —> If Low-High is selected, the high level brings about the corresponding setting.

## 3.2 Current inputs

The current input must be assigned an analog signal for the functions described. Active and passive current inputs are available to connect two-wire or four-wire devices.

For the correct wiring of the current inputs, see:  
BA00443C "Commissioning"

### Path: Menu/Setup/Inputs

Function	Options	Info
▶ Current input S:x		
Mode	Options <ul style="list-style-type: none"> <li>■ Off</li> <li>■ 0..20 mA</li> <li>■ 4..20 mA</li> </ul> <b>Factory setting</b> Off	Enter the output signal of the connected device: 0 to 20 mA or 4 to 20 mA.
Input mode	Options <ul style="list-style-type: none"> <li>■ Flow rate</li> <li>■ Parameter</li> <li>■ Current</li> </ul> <b>Factory setting</b> Current	Select the input variable. <b>Flow rate:</b> The input can be used as the source for time/flow-paced or flow-paced sampling programs. <b>Parameter:</b> The input can be used as the source for limit switches, logbooks and enabling and disabling events for sampling programs. <b>Current:</b> The input can be used as the source for limit switches, logbooks and enabling and disabling events for sampling programs. A unit name cannot be specified.
If Input mode <b>Flow rate</b> is selected:		
Unit of flow	Options <ul style="list-style-type: none"> <li>■ l/s</li> <li>■ m<sup>3</sup>/s</li> <li>■ m<sup>3</sup>/h</li> <li>■ m<sup>3</sup>/d</li> <li>■ cfs</li> <li>■ cfm</li> <li>■ gpm</li> <li>■ gph</li> <li>■ mgd</li> </ul> <b>Factory setting</b> l/s	Select the unit.
Unit of totalized flow	Options <ul style="list-style-type: none"> <li>■ l</li> <li>■ m<sup>3</sup></li> <li>■ cf</li> <li>■ gal</li> </ul> <b>Factory setting</b> m <sup>3</sup>	Select the unit for the totalized flow.

## Path: Menu/Setup/Inputs

Function	Options	Info
Meas. value format	<b>Factory setting</b> #.#	Specify the number of decimal places for the flow.
Minimum flow	0 to 10000 l/s <b>Factory setting</b> 0 l/s	The set limit value prevents sampling if the flow falls below this value (only for time/flow-paced sampling).
Lower range value	0 to 10000 l/s <b>Factory setting</b> 0 l/s	Enter a value for the start of the measuring range. 0/4 mA is assigned to this value as per your specifications.
Upper range value	0 to 10000 l/s <b>Factory setting</b> 100000 l/s	Enter a value for the end of the measuring range. 20 mA is assigned to this value as per your specifications.
Damping	0 to 60 s <b>Factory setting</b> 0 s	The damping causes a floating average curve of the measured values over the time specified.
<p>► Totalized flow</p> <p> The totalized flow is calculated when the program is started if you use a sampling program with volume, flow-paced sampling or time/flow-paced sampling as the start condition. The samples are taken based on this value. The current totalizer is used for calculating purposes if the totalized flow is used as the measured value for an enabling or disabling event.</p>		
Current totalized flow	---	The totalized flow values are displayed.
Reset totalizer	Options <ul style="list-style-type: none"> <li>■ Manual</li> <li>■ Automatic</li> <li>■ At program start</li> </ul> <b>Factory setting</b> Manual	<b>Manual:</b> Reset the counter manually. <b>Automatic:</b> The counter is reset automatically at intervals. <b>At program start:</b> The counter is reset at program start.
Flow rate	---	The current flow rate is displayed.
If counter reset <b>Manual</b> is selected:		
► Reset totalized flow	Action	The totalized flow currently calculated is set to zero when the counter is reset.
If counter reset <b>Automatic</b> is selected:		
Interval	Options <ul style="list-style-type: none"> <li>■ Daily</li> <li>■ Weekly</li> <li>■ Monthly</li> </ul> <b>Factory setting</b> Daily	<b>Daily:</b> If a daily interval is selected, set the Time in the menu item that follows. <b>Weekly:</b> If a weekly interval is selected, set the Day of week and the Time in the menu items that follow. <b>Monthly:</b> If a monthly interval is selected, set the Day of month and the Time in the menu items that follow.

**Path: Menu/Setup/Inputs**

Function	Options	Info
If Input mode <b>Parameter</b> is selected:		
Meas. value format	<b>Factory setting</b> #.#	Specify the number of decimal places.
Parameter name	Customized text	Assign a name.
Unit of measure	Customized text	Enter the engineering unit.
Lower range value	-20 to 10000 <b>Factory setting</b> 0	Enter a value for the start of the measuring range. 0/4 mA is assigned to this value as per your specifications.
Upper range value	-20 to 10000 <b>Factory setting</b> 10	Enter a value for the end of the measuring range. 20 mA is assigned to this value as per your specifications.
Damping	0 to 60 s <b>Factory setting</b> 0 s	The damping causes a floating average curve of the measured values over the time specified.
If Input mode <b>Current</b> is selected:		
Meas. value format	<b>Factory setting</b> #.#	Specify the number of decimal places.
Damping	0 to 60 s <b>Factory setting</b> 0 s	The damping causes a floating average curve of the measured values over the time specified.

## 4 Programming

The Liquistation CSF48 offers a wide range of options for configuring individual sampling programs. The 3 different program types (Basic, Standard and Advanced) make it easy for you to find the right program for your application.

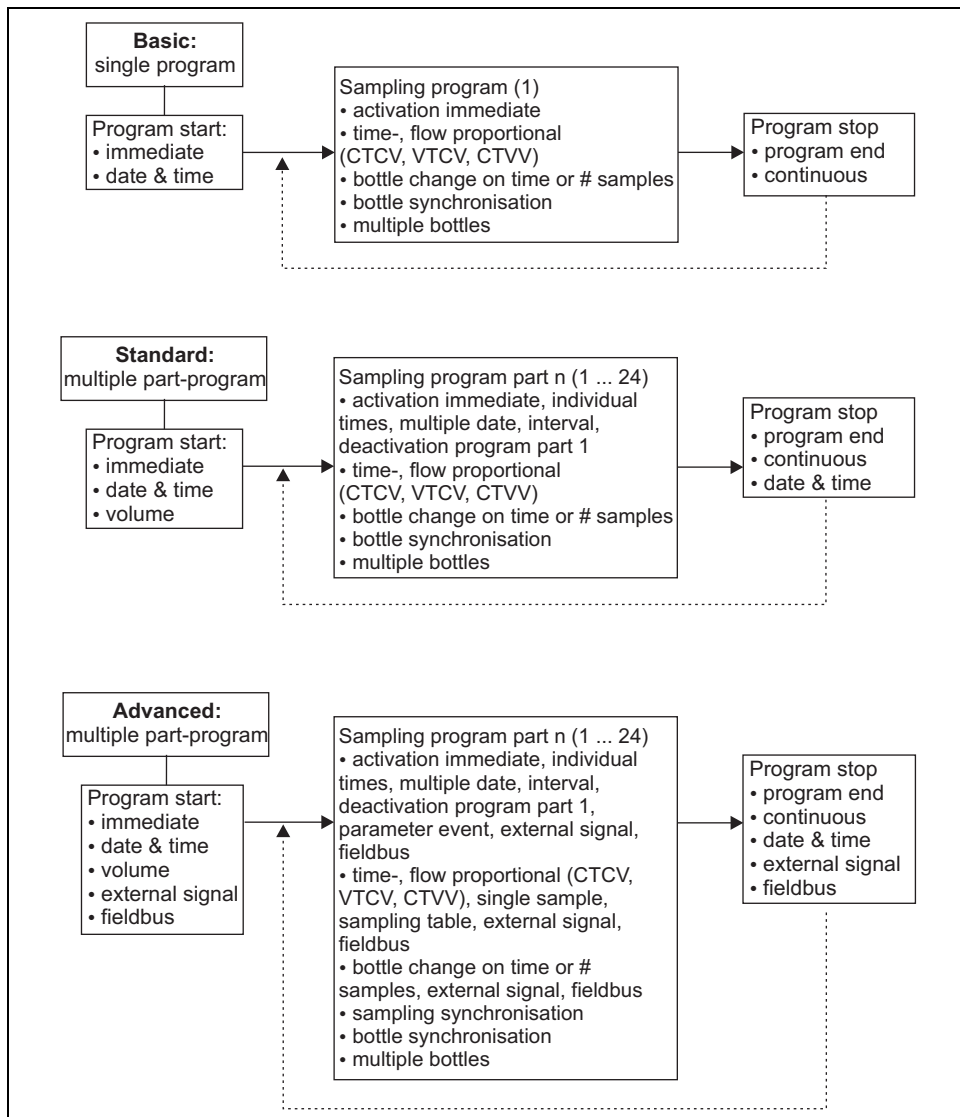

a0017981-en

## 4.1 Overview of the possible program types

Sampler version	Basic program type	Standard program type	Advanced program type
Vacuum/peristaltic pump, Sampling assembly	Time-paced	Time-paced	Time-paced
	Flow-paced	Flow-paced	Flow-paced
			Single sample
			Sampling table
			External signal
		Fieldbus (optional)	
Peristaltic pump	Time/flow-paced	Time/flow-paced	Time/flow-paced

The graphic below explains the various ways sampling can be controlled on the basis of a flow curve:

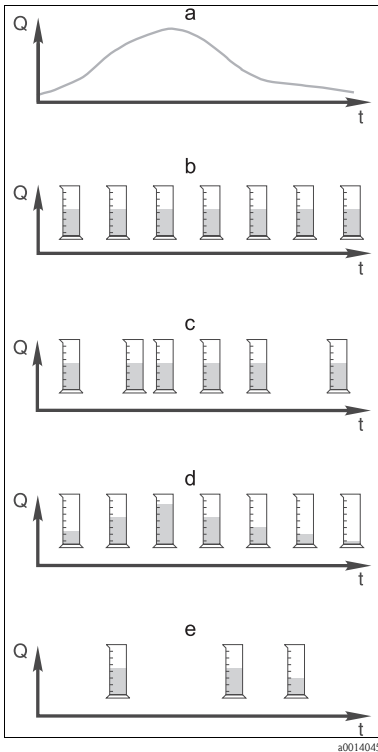

- a. Flow curve
- b. **Time-paced sampling**  
A constant sampling volume (e.g. 50 ml) is taken at steady intervals (e.g. every 5 min).
- c. **Flow-paced sampling**  
A constant sampling volume is taken at variable intervals (depending on the inflow volume).
- d. **Time/flow-paced sampling**  
A variable sampling volume (the sampling volume depends on the inflow) is taken at steady time intervals (e.g. every 10 min).
- e. **Event-controlled sampling**  
Sampling is triggered by an event (e.g. pH limit value). Sampling can be time-paced, flow-paced, or time/flow-paced, or single samples can be taken.

Fig. 7: Sampling control

a0014045



The following table explains the various types of sampling using specific examples.

Type of sampling	Example	Info
<b>Time-paced</b>	<ul style="list-style-type: none"> <li>■ Sampling interval: 5 min</li> <li>■ Sampling volume: 50 ml</li> <li>■ Bottle change mode: 2 h</li> </ul> <p>With this setting, a 50 ml sample is taken every 5 minutes. 12 samples are thus taken every hour. Each bottle is filled over a period of 2 hours. This results in a total sampling volume of 24 samples per bottles x 50 ml = 1200 ml.</p>	<p>This type of sampling remains constant over time and does not take changes in flow or polluting load into account. It is possible to take a representative sample if the intervals are brief (e.g. 5 min).</p>
<b>Flow-paced</b>	<p><b>Controlled via current input</b></p> <ul style="list-style-type: none"> <li>■ Signal: 0 to 20 mA = 0 to 600 m<sup>3</sup>/h</li> <li>■ Sampling volume: 50 ml</li> <li>■ Sampling interval: 20 m<sup>3</sup></li> <li>■ Bottle change mode: 2 h</li> </ul> <p>If 20 mA = 600 m<sup>3</sup>/h, a sample is taken every 2 minutes (smallest sampling interval with maximum flow). The total number of samples amounts to 60 samples per bottle. With a flow of 300 m<sup>3</sup>/h, a sample is taken every 4 minutes.</p> <p><b>Controlled via binary input</b></p> <ul style="list-style-type: none"> <li>■ Signal pulse: 5 m<sup>3</sup></li> <li>■ Sampling volume: 50 ml</li> <li>■ Sampling interval: 20 m<sup>3</sup></li> <li>■ Bottle change mode: 2 h</li> </ul> <p>The pulses are scaled at the flowmeter. By multiplying the pulses at the sampling interval, the shortest sampling interval at the maximum pulse frequency can be set.</p> <p>Example: Given a maximum flow of 600 m<sup>3</sup>/h, the pulse frequency at 5 m<sup>3</sup> is 120 pulses/h or 2 pulses/min. With a sampling interval of 20 m<sup>3</sup>, sampling takes place after 4 pulses = 2 minutes.</p>	<ul style="list-style-type: none"> <li>■ The current inputs can be configured for the current range of 0 to 20 mA or 4 to 20 mA.</li> <li>■ The binary inputs require power (24 V DC) for floating contacts.</li> </ul> <p>In the case of flow-paced sampling, the sampling interval is calculated on the basis of the volume flow. The same sampling volume is take at variable intervals.</p> <p><b>Advantage:</b> Good, representative results in the event of minor fluctuations in flow.</p> <p><b>Disadvantage:</b> Longer intervals when the level of water is low mean that malfunctions cannot be detected.</p>

Type of sampling	Example	Info
<p><b>Time/flow-paced</b> (only possible with peristaltic pump)</p>	<p><b>Controlled via current input</b></p> <ul style="list-style-type: none"> <li>■ Signal: 0 to 20 mA</li> <li>■ Sampling interval: 10 min</li> <li>■ Sampling volume: variable</li> </ul> <p>The maximum sampling volume is defined at the maximum flow rate.                      Example: The maximum flow rate at 20 mA at the current input is 160 l/s, and the maximum sampling volume is 200 ml. When transferring samples into a 30l mixed sample container, 144 samples are taken per day with a maximum sampling volume of 28.8 l. With a flow rate of 80 l/s, a sampling volume of only 100 ml would be grabbed, and a sampling volume of 50 ml would be grabbed at a flow rate of 40 l/s.                      The sampling volume is always calculated based on the flow.</p> <p><b>Controlled via binary input</b></p> <ul style="list-style-type: none"> <li>■ Binary input (pulse per flow unit)</li> <li>■ Sampling interval: 10 min</li> <li>■ Sampling volume: variable</li> </ul> <p>The sampling volume is defined for a flow pulse, e.g.: 1 pulse is 20 ml. For instance, if 5 flow pulses are counted between the sampling intervals, this results in a sampling volume of <math>5 \times 20 = 100</math> ml, and a volume of <math>8 \times 20 = 160</math> ml for 8 pulses.                      If a binary input is used for time/flow-paced sampling, the sampling volume is calculated per sample as a percentage of the specified sampling volume.</p>	<p>Samples are taken at set intervals with a variable sampling volume. The sampling volume is calculated from the <b>flow rate</b>. More volume is grabbed when the flow is high than when it is low. Since the flow normally fluctuates and the maximum flow is only rarely a constant variable, the sampling volume transferred to the container will depend on the daily average.</p> <p><b>Advantage:</b>                      Very good, representative sampling given large fluctuations in the flow and constant time intervals.</p> <p><b>Disadvantage:</b>                      Too little sampling volume is made available for analysis when the flow is low.</p> <p><b>Advantage with current input:</b>                      For the sampling interval, either the current flow rate or the average value between the last and current flow rate is used to calculate the exact sampling volume (depending on the presetting).</p> <p><b>Disadvantage with binary input:</b>                      For the sampling interval, the pulses counted since the last sampling are multiplied by a volume. If this is too high - e.g. 100 ml - the composition of the sample is not representative for analysis.</p>
<p><b>Event</b></p>	<p>Event-based sampling is controlled via the current input, binary input and/or sensor input. The subprogram created waits to be activated by an event that can consist of up to 3 individual events. Every possible condition can be created using logical "and" / "or" links. For example, the information from a flowmeter connected to the current input can be linked to a rain gage and a pH sensor signal connected to the binary input. An event is defined as limit value violation (exceeded or undershot), range monitoring within or outside a range, or a rate of change. Users can decide whether additional sampling is started when the event starts and/or ends. For the duration of the event, users can choose from time-paced, flow-paced or time/flow-paced sampling, or can take single samples, use a sampling table or the external control system.</p>	<p>The sampler waits for an event. This event takes place via internal sensor signal processing or via devices connected externally. As bottle assignment is possible when using several bottles, events can be assigned to individual bottles. A maximum of 24 subprograms can be started simultaneously and assigned to individual bottles.</p>

### 4.1.1 Bottle synchronization

The bottle synchronization setting is possible with all types of program. In addition, bottle synchronization can be switched via an external signal.

Bottle synchronization is only possible with a bottle change after a specific time and not with a bottle change after a number of samples.

Specific bottles can be assigned specific filling times with the bottle synchronization function. For example, bottle 1 is to be filled from midnight to 2 a.m., bottle 2 from 2 a.m. to 4 a.m. etc.. The following options are available for this:

- None: The time of sampling and bottle change are not synchronized.
- 1. bottle change time: Sampling starts with the first bottle. The changeover to the next bottles is synchronized. For example, a time of 2 hours was set for bottle changeover, and 00:00 was set for the synchronization. If the program is started at 5:23 a.m., for example, bottle 1 is initially filled. The system switches for the first time to bottle 2 at midnight (00:00), to bottle 3 at 2 a.m. etc.
- 1. Time of change + bottle number: A specific filling time is assigned to every bottle. For example, midnight to 2 a.m. for bottle 1; 2 a.m. to 4 a.m. for bottle 2; 4 a.m. to 6 a.m. for bottle 3 etc. If the program is started at 10 a.m., for example, the device starts filling bottle 6. It is also possible to start synchronization on a specific day of the week. For example, a time of 24 hours was set for bottle changeover, Monday 00:00 was the time set for synchronization, and Tuesday 8 a.m. was set for starting the program. The system fills bottle 2 until 00:00 on Wednesday and then switches to bottle 3.
- External signal: The system changes to the next bottle when an external signal is received. The external signal first has to be configured via the binary input. The binary input can then be selected as the source.

## 4.2 Program type: Basic

With the Basic program type, you can create simple sampling programs quickly based on time, volume and flow. In the case of volume- and flow-controlled sampling, the inputs have to be configured appropriately beforehand. If you want to create a program and use it immediately, you have to check the configuration of the sampler before programming. You can make the settings under "Menu/Setup/General settings/Sampling": e.g. the bottle configuration, and the bottle volume, as well as the correct dosing volume for the device version with a vacuum pump. The dosing volume setting makes it possible to correctly calculate the level in the bottle and is a reliable way of preventing the bottles from being overfilled.

-  You can go to the Setup program either via the overview under "Select sampling program" or via the path "Menu/Setup/Sampling programs".

**Path: Menu/Setup/Sampling programs**

Function	Options	Info
Current program:	Read only	The last sampling program to be created or used is displayed.
Status:	Read only	Display "Active": The sampling program has been started and the device takes a sample as per the set parameters. Display "Inactive": No sampling program has been started, or a program that was running has been paused. Display "Pause": Sampling program paused.
▶ Setup program		
New		A list of all the programs created is displayed. For this reason, it is often helpful to add a "B" for Basic in the program name.
	<p>Program 1, which is supplied with the device, is displayed, as is a list of all the programs already created (Basic, Standard or Advanced programs). You can either create a new program or select an existing one. You can edit, delete, start or duplicate an existing program.</p> <p>If you are creating a new program, select the Basic, Standard or Advanced program type.</p>	
▶ Basic		
Program name	Customized text	Use a distinct name for your sampling program. The program name can be up to 16 characters long.
Bottle configuration	<p>Choice of all possible bottle combinations</p> <p><b>Options:</b></p> <ul style="list-style-type: none"> <li>- 1x - PE direct distribution</li> <li>- 2x - PE direct distribution</li> <li>- 4x - PE direct distribution</li> <li>- 4x - glass direct distribution</li> <li>- 12x - PE direct distribution</li> <li>- 12x - PE/glass distributor plate</li> <li>- 24x - PE direct distribution</li> <li>- 24x - PE/glass distributor plate</li> <li>- 6x+1x - PE/glass distributor plate</li> <li>- 6x+2x - PE+PE distributor plate</li> <li>- 6x+2x - PE+glass distributor plate</li> <li>- 12x+1x - PE/glass distributor plate</li> <li>- 12x+2x - PE+PE distributor plate</li> <li>- 12x+2x - PE+glass distributor plate</li> <li>- 12x+6x PE direct distribution</li> <li>- 12x+6x PE/glass distributor plate</li> </ul>	The ordered bottle configuration is preset or the configuration selected in the setup is displayed.

**Path: Menu/Setup/Sampling programs**

Function	Options	Info
Bottle volume	0 to 100000 ml <b>Factory setting</b> 30000 ml	Set the bottle volume. The preset value depends on the bottle configuration configured. The bottle volume is always 30 l for individual containers.  In the case of asymmetric distribution, e.g. $6 \times 3 \text{ l} + 2 \times 13 \text{ l}$ , you can set the bottle volume on the left and right in the menu items that follow.
Sampling mode	Options <ul style="list-style-type: none"> <li>■ Time paced CTCV</li> <li>■ Flow paced VTCV</li> <li>■ Time/flow paced CTVV</li> </ul> <b>Factory setting</b> Time paced CTCV	The following functions depend on the option selected. These versions are illustrated individually in the following section to provide a clearer understanding of the options. <b>Time paced CTCV:</b> A constant sampling volume is taken at steady intervals. <b>Flow paced VTCV:</b> A constant sampling volume is taken at variable intervals. <b>Time/flow paced CTVV only for version with peristaltic pump:</b> A variable sampling volume is taken at steady intervals.

#### 4.2.1 Settings with a time-paced Basic program



##### Settings with the Basic program type with 1 bottle

Sampling mode = "Time paced CTCV"

**Path: Menu/Setup/Sampling programs/Setup program/New/Basic**

Function	Options	Info
Sampling interval (for version with vacuum pump or peristaltic pump)	00:01:00 to 99:59:00 HH:MM:SS <b>Factory setting</b> 00:10:00 HH:MM:SS	Set the sampling interval.
Sampling interval (for version with sampling assembly)	00:00:10 to 99:59:00 HH:MM:SS <b>Factory setting</b> 00:10:00 HH:MM:SS	

**Path: Menu/Setup/Sampling programs/Setup program/New/Basic**

Function	Options	Info
Dosing volume (for version with vacuum pump or sampling assembly) Sampling volume(for version with peristaltic pump)	Vacuum pump: 20 to 350 ml  Peristaltic pump: 10 to 10000 ml or maximum bottle volume  Sampling assembly: 10, 30, 50 ml  <b>Factory setting</b> Vacuum pump: 200 ml Peristaltic pump: 100 ml Sampling assembly: 10 ml	Set the dosing volume or the sampling volume.  In the version with a vacuum pump or sampling assembly, the volume is taken from the setup and can only be modified there.  The dosing accuracy and the repeatability of a sample volume < 20 ml can vary, depending on the specific application.
Multiplier (for version with vacuum pump or sampling assembly)	1 to 10  <b>Factory setting</b> 1	You can change the sampling volume using the multiplier. For example, if the dosing volume is set to 200 ml, set the multiplier to 2 for a sampling volume of 400 ml. 2 samples are taken in succession when sampling.
Bottle change mode	Options <ul style="list-style-type: none"> <li>■ Number of samples</li> <li>■ Time</li> </ul> <b>Factory setting</b> Number of samples	The bottle is changed either after a specific number of samples or after a time.
Samples per bottle	1 to 9999  <b>Factory setting</b> 1	Set the number of samples. If the bottle is full beforehand based on the calculated level, the system prevents more samples being added to the bottle. Such samples are logged as failed samples in the program logbook. At the same time, the diagnostics message "Overfill check" (F353) is also triggered.
Start condition	Options <ul style="list-style-type: none"> <li>■ Immediate</li> <li>■ Date/time</li> </ul> <b>Factory setting</b> Immediate	The sampling program can be started either immediately or at a specific, configurable time.
If Start condition <b>Date/time</b> is selected:		
Start date	01.01.2000 to 31.12.2099  <b>Factory setting</b> DD.MM.YYYY	Set the start date for the sampling program. The format depends on the option configured under general settings.
Start time	00:00:00 to 23:59:59  <b>Factory setting</b> HH:MM:SS (24h)	Set the time when the sampling program is started. The format depends on the option configured under general settings.



**Path: Menu/Setup/Sampling programs/Setup program/New/Basic**

Function	Options	Info
Stop condition	Options <ul style="list-style-type: none"> <li>■ Program end</li> <li>■ Continuous</li> </ul> <b>Factory setting</b> Program end	<b>Program end:</b> The device stops sampling automatically once it has run through the set program.  <b>Continuous:</b> The device runs through the set program continuously in an infinite loop. Do not forget to empty the bottles.
Assignment bin. output	Options <ul style="list-style-type: none"> <li>■ No binary output config. for state reporting</li> <li>■ Binary output S:x</li> </ul> <b>Factory setting</b> No binary output config. for state reporting	Assignment of the binary output to the program cycle.



**Settings with the Basic program type with multiple bottles**

Sampling mode = "Time paced CTCV"

**Path: Menu/Setup/Sampling programs/Setup program/New/Basic**

Function	Options	Info
Sampling interval (for version with vacuum pump or peristaltic pump)	00:01:00 to 99:59:00 HH:MM:SS  <b>Factory setting</b> 00:10:00 HH:MM:SS	Set the sampling interval.
Sampling interval (for version with sampling assembly)	00:00:10 to 99:59:00 HH:MM:SS  <b>Factory setting</b> 00:10:00 HH:MM:SS	
Dosing volume (for version with vacuum pump or sampling assembly) Sampling volume(for version with peristaltic pump)	Vacuum pump: 20 to 350 ml  Peristaltic pump: 10 to 10000 ml or maximum bottle volume  Sampling assembly: 10, 30, 50 ml  <b>Factory setting</b> Vacuum pump: 200 ml Peristaltic pump: 100 ml Sampling assembly: 10 ml	Set the dosing volume or the sampling volume.   The volume is taken from the setup in the version with a vacuum pump or sampling assembly.   The dosing accuracy and the repeatability of a sample volume < 20 ml can vary, depending on the specific application.
Multiplier (only for version with vacuum pump or sampling assembly)	1 to 10  <b>Factory setting</b> 1	You can change the sampling volume using the multiplier. For example, if the dosing volume is set to 200 ml, set the multiplier to 2 for a sampling volume of 400 ml. 2 samples are taken in succession when sampling.

**Path: Menu/Setup/Sampling programs/Setup program/New/Basic**

Function	Options	Info
Bottle change mode	Options <ul style="list-style-type: none"> <li>■ Number of samples</li> </ul> <b>Factory setting</b> Number of samples	The bottle is changed either after a specific number of samples or after a time.
If Bottle change mode <b>Number of samples</b> is selected:		
Samples per bottle	1 to 9999 <b>Factory setting</b> 1	Set the number of samples.  If the bottle is full beforehand based on the calculated level, the system prevents more samples being added to the bottle. Such samples are logged as failed samples in the program logbook.
If Bottle change mode <b>Time</b> is selected:		
Time interval	00-00:02 to 31-00:00 DD-HH:MM <b>Factory setting</b> 00-01:00 DD-HH:MM	Set the time (days, hours and minutes) after which the system should change to the next bottle.
Multiple bottles	0 to 23  The configuration options depend on the current number of bottles <b>Factory setting</b> 0	Multiple bottles: "Simultaneous" transfer of two samples to separate bottles.
Bottle synchronization	Options <ul style="list-style-type: none"> <li>■ None</li> <li>■ 1. bottle change time</li> <li>■ 1. Time of change + bottle number</li> </ul> <b>Factory setting</b> None	None: The time of sampling and bottle change are not synchronized.  1. bottle change time: Sampling starts with the first bottle. Set the synchronization time.  1. Time of change + bottle number: Each bottle is assigned to a specific fill time. Set the synchronization time and the weekday.
Start condition	Options <ul style="list-style-type: none"> <li>■ Immediate</li> <li>■ Date/time</li> </ul> <b>Factory setting</b> Immediate	The sampling program can be started either immediately or at a specific, configurable time.
If Start condition <b>Date/time</b> is selected:		
Start date	01.01.2000 to 31.12.2099 <b>Factory setting</b> DD.MM.YYYY	Set the start date for the sampling program. The format depends on the option configured under general settings.
Start time	00:00:00 to 23:59:59 <b>Factory setting</b> HH:MM:SS (24h)	Set the time when the sampling program is started. The format depends on the option configured under general settings.



---

**Path: Menu/Setup/Sampling programs/Setup program/New/Basic**



Function	Options	Info
Stop condition	Options <ul style="list-style-type: none"> <li>■ Program end</li> <li>■ Continuous</li> </ul> <b>Factory setting</b> Program end	<b>Program end:</b> The device stops sampling automatically once it has run through the set program.  <b>Continuous:</b> The device runs through the set program continuously in an infinite loop. Do not forget to empty the bottles. The bottle level is reset once a program loop has been run through.
Assignment bin. output	Options <ul style="list-style-type: none"> <li>■ No binary output config. for state reporting</li> <li>■ Binary output S:x</li> </ul> <b>Factory setting</b> No binary output config. for state reporting	Assignment of the binary output to the program cycle.

## 4.2.2 Settings with a flow-paced Basic program

### Settings with the Basic program type with 1 bottle

Sampling mode = "Flow paced VTCV"

Path: Menu/Setup/Sampling programs/Setup program/New/Basic

Function	Options	Info
Flowmeter input	Options <ul style="list-style-type: none"> <li>■ No flow input configured</li> <li>■ Binary input S:x</li> <li>■ Current input S:x</li> </ul> <b>Factory setting</b> No flow input configured	Select the flow input. The binary input or the current input must be configured for this function. Only the inputs configured as a flow input are displayed.
Sampling interval (for versions with vacuum pump or peristaltic pump)	1.000 to 9999.000 m <sup>3</sup> <b>Factory setting</b> 10.000 m <sup>3</sup>	Set the sampling interval. The unit and the number of decimal places are displayed as configured under Setup/Inputs.
Dosing volume (for version with vacuum pump or sampling assembly) Sampling volume(for version with peristaltic pump)	Vacuum pump: 20 to 350 ml  Peristaltic pump: 10 to 10000 ml or maximum bottle volume  Sampling assembly: 10, 30, 50 ml  <b>Factory setting</b> Vacuum pump: 200 ml Peristaltic pump: 100 ml Sampling assembly: 10 ml	Set the dosing volume or the sampling volume.  The volume is taken from the setup in the version with a vacuum pump or sampling assembly.   The dosing accuracy and the repeatability of a sample volume < 20 ml can vary, depending on the specific application.
Multiplier (only for version with vacuum pump or sampling assembly)	1 to 10 <b>Factory setting</b> 1	You can change the sampling volume using the multiplier. For example, if the dosing volume is set to 200 ml, set the multiplier to 2 for a sampling volume of 400 ml. 2 samples are taken in succession when sampling.
Bottle change mode	Options <ul style="list-style-type: none"> <li>■ Number of samples</li> <li>■ Time</li> </ul> <b>Factory setting</b> Number of samples	The bottle is changed either after a specific number of samples or after a time.
Samples per bottle	1 to 9999 <b>Factory setting</b> 1	Set the number of samples.
Start condition	Options <ul style="list-style-type: none"> <li>■ Immediate</li> <li>■ Date/time</li> </ul> <b>Factory setting</b> Immediate	The sampling program can be started either immediately or at a specific, configurable time.



**Path: Menu/Setup/Sampling programs/Setup program/New/Basic**

Function	Options	Info
If Start condition <b>Date/time</b> is selected:		
Start date	01.01.2000 to 31.12.2099 <b>Factory setting</b> DD.MM.YYYY	Set the start date for the sampling program. The format depends on the option configured under general settings.
Start time	00:00:00 to 23:59:59 <b>Factory setting</b> HH:MM:SS (24h)	Set the time when the sampling program is started. The format depends on the option configured under general settings.
Stop condition	Options <ul style="list-style-type: none"> <li>■ Program end</li> <li>■ Continuous</li> </ul> <b>Factory setting</b> Program end	<b>Program end:</b> The device stops sampling automatically once it has run through the set program.  <b>Continuous:</b> The device runs through the set program continuously in an infinite loop. Do not forget to empty the bottles.
Assignment bin. output	Options <ul style="list-style-type: none"> <li>■ No binary output config. for state reporting</li> <li>■ Binary output S:x</li> </ul> <b>Factory setting</b> No binary output config. for state reporting	Assignment of the binary output to the program cycle.

## Settings with the Basic program type with multiple bottles

Sampling mode = "Flow paced VTCV"

Path: Menu/Setup/Sampling programs/Setup program/New/Basic

Function	Options	Info
Flowmeter input	Options <ul style="list-style-type: none"> <li>■ No flow input configured</li> <li>■ Binary input S:x</li> <li>■ Current input S:x</li> </ul> <b>Factory setting</b> No flow input configured	Select the flow input. The binary input or the current input must be configured for this function. Only the inputs configured as a flow input are displayed.
Sampling interval (for version with vacuum pump or peristaltic pump)	1.000 to 9999.000 m <sup>3</sup> <b>Factory setting</b> 10.000 m <sup>3</sup>	Set the sampling interval. The unit and the number of decimal places are displayed as configured under Setup/Inputs.
Dosing volume (for version with vacuum pump or sampling assembly) Sampling volume(for version with peristaltic pump)	Vacuum pump: 20 to 350 ml  Peristaltic pump: 10 to 10000 ml or maximum bottle volume  Sampling assembly: 10, 30, 50 ml  <b>Factory setting</b> Vacuum pump: 200 ml Peristaltic pump: 100 ml Sampling assembly: 10 ml	Set the dosing volume or the sampling volume.  The volume is taken from the setup in the version with a vacuum pump or sampling assembly.   The dosing accuracy and the repeatability of a sample volume < 20 ml can vary, depending on the specific application.
Multiplier (only for version with vacuum pump)	1 to 10 <b>Factory setting</b> 1	You can change the sampling volume using the multiplier. For example, if the dosing volume is set to 200 ml, set the multiplier to 2 for a sampling volume of 400 ml. 2 samples are taken in succession when sampling.
Bottle change mode	Options <ul style="list-style-type: none"> <li>■ Number of samples</li> <li>■ Time</li> </ul> <b>Factory setting</b> Number of samples	The bottle is changed either after a specific number of samples or after a time.
If Bottle change mode <b>Number of samples</b> is selected:		
Samples per bottle	1 to 9999 <b>Factory setting</b> 1	Set the number of samples.
If Bottle change mode <b>Time</b> is selected:		
Time interval	00-00:02 to 31-00:00 DD-HH:MM <b>Factory setting</b> 00-01:00 DD-HH:MM	Set the time (in days, hours and minutes) after which the system should change to the next bottle.

## Path: Menu/Setup/Sampling programs/Setup program/New/Basic



Function	Options	Info
Multiple bottles	0 to 23  The configuration options depend on the current number of bottles.  <b>Factory setting</b> 0	Multiple bottles: "Simultaneous" transfer of two samples to separate bottles.
Bottle synchronization	Options <ul style="list-style-type: none"> <li>■ None</li> <li>■ 1. bottle change time</li> </ul> <b>Factory setting</b> None	None: The time of sampling and bottle change are not synchronized.  1. bottle change time: Sampling starts with the first bottle.  1. Time of change + bottle number: Each bottle is assigned to a specific fill time.
Start condition	Options <ul style="list-style-type: none"> <li>■ Immediate</li> <li>■ Date/time</li> </ul> <b>Factory setting</b> Immediate	The sampling program can be started either immediately or at a specific, configurable time.
If Start condition <b>Date/time</b> is selected:		
Start date	01.01.2000 to 31.12.2099  <b>Factory setting</b> DD.MM.YYYY	Set the start date for the sampling program. The format depends on the option configured under general settings.
Start time	00:00:00 to 23:59:59  <b>Factory setting</b> HH:MM:SS (24h)	Set the time when the sampling program is started. The format depends on the option configured under general settings.
Stop condition	Options <ul style="list-style-type: none"> <li>■ Program end</li> <li>■ Continuous</li> </ul> <b>Factory setting</b> Program end	<b>Program end:</b> The device stops sampling automatically once it has run through the set program.  <b>Continuous:</b> The device runs through the set program continuously in an infinite loop. Do not forget to empty the bottles.
Assignment bin. output	Options <ul style="list-style-type: none"> <li>■ No binary output config. for state reporting</li> <li>■ Binary output S:x</li> </ul> <b>Factory setting</b> No binary output config. for state reporting	Assignment of the binary output to the program cycle.

### 4.2.3 Settings with a time/flow-paced Basic program (only for version with peristaltic pump)

#### Settings with the Basic program type with 1 bottle

Sampling mode = "Time/flow paced CTVV"

Path: Menu/Setup/Sampling programs/Setup program/New/Basic

Function	Options	Info
Sampling volume input	Options <ul style="list-style-type: none"> <li>■ No flow input configured</li> <li>■ Binary input S:x</li> <li>■ Current input S:x</li> </ul> <b>Factory setting</b> No flow input configured	Select the sampling volume input. The binary input or the current input must be configured for this function. Only the inputs configured as a sampling volume input are displayed.
Sampling interval	00:01:00 to 99:59:00 HH:MM:SS <b>Factory setting</b> 00:10:00 HH:MM:SS	Set the sampling interval.
If Sampling volume input <b>Binary input</b> is selected:		
Sampling volume / pulse	10 to 1000 ml or maximum bottle volume (depending on what is smaller) <b>Factory setting</b> 20 ml	Set what sampling volume should be grabbed per pulse.  The dosing accuracy and the repeatability of a sample volume < 20 ml can vary, depending on the specific application.
If Sampling volume input <b>Current input</b> is selected:		
Sampling volume 20mA	10 to 10000 ml or maximum bottle volume (depending on what is smaller) <b>Factory setting</b> 100 ml	Set what sampling volume should be grabbed at 20 mA.  The dosing accuracy and the repeatability of a sample volume < 20 ml can vary, depending on the specific application.
Flow calculation	Options <ul style="list-style-type: none"> <li>■ Current</li> <li>■ Average flow</li> </ul> <b>Factory setting</b> Current	<b>Current:</b> The current flow is converted to the sampling volume at the time of sampling. <b>Average flow:</b> The system calculates the mean between the last and the current sample and sets the sampling volume accordingly.
Samples per bottle	1 to 9999 <b>Factory setting</b> 1	Set the number of samples.
Start condition	Options <ul style="list-style-type: none"> <li>■ Immediate</li> <li>■ Date/time</li> </ul> <b>Factory setting</b> Immediate	The sampling program can be started either immediately or at a specific, configurable time.

**Path: Menu/Setup/Sampling programs/Setup program/New/Basic**

Function	Options	Info
If Start condition <b>Date/time</b> is selected:		
Start date	01.01.2000 to 31.12.2099 <b>Factory setting</b> DD.MM.YYYY	Set the start date for the sampling program. The format depends on the option configured under general settings.
Start time	00:00:00 to 23:59:59 <b>Factory setting</b> HH:MM:SS (24h)	Set the time when the sampling program is started. The format depends on the option configured under general settings.
Stop condition	Options <ul style="list-style-type: none"> <li>■ Program end</li> <li>■ Continuous</li> </ul> <b>Factory setting</b> Program end	<b>Program end:</b> The device stops sampling automatically once it has run through the set program.  <b>Continuous:</b> The device runs through the set program continuously in an infinite loop. Do not forget to empty the bottles.
Assignment bin. output	Options <ul style="list-style-type: none"> <li>■ No binary output config. for state reporting</li> <li>■ Binary output S:x</li> </ul> <b>Factory setting</b> No binary output config. for state reporting	Assignment of the binary output to the program cycle.



**Settings with the Basic program type with multiple bottles**

Sampling mode = "Time/flow paced CTVV"

**Path: Menu/Setup/Sampling programs/Setup program/New/Basic**

Function	Options	Info
Sampling volume input	Options <ul style="list-style-type: none"> <li>■ No flow input configured</li> <li>■ Binary input S:x</li> <li>■ Current input S:x</li> </ul> <b>Factory setting</b> No flow input configured	Select the sampling volume input. The binary input or the current input must be configured for this function. Only the inputs configured as a sampling volume input are displayed.
Sampling interval	00:01:00 to 99:59:00 HH:MM:SS <b>Factory setting</b> 00:10:00 HH:MM:SS	Set the sampling interval.

**Path: Menu/Setup/Sampling programs/Setup program/New/Basic**

Function	Options	Info
If Sampling volume input <b>Binary input</b> is selected:		
Sampling volume / pulse	10 to 1000 ml or maximum bottle volume (depending on what is smaller)  <b>Factory setting</b> 20 ml	Set what sampling volume should be grabbed per pulse.  The dosing accuracy and the repeatability of a sample volume < 20 ml can vary, depending on the specific application.
If Sampling volume input <b>Current input</b> is selected:		
Sampling volume 20mA	10 to 10000 ml or maximum bottle volume (depending on what is smaller)  <b>Factory setting</b> 100 ml	Set what sampling volume should be grabbed at 20 mA.  The dosing accuracy and the repeatability of a sample volume < 20 ml can vary, depending on the specific application.
Flow calculation	Options <ul style="list-style-type: none"> <li>■ Current</li> <li>■ Average flow</li> </ul> <b>Factory setting</b> Current	<b>Current:</b> The current flow is converted to the sampling volume at the time of sampling.  <b>Average flow:</b> The system calculates the mean between the last and the current sample and sets the sampling volume accordingly.
Bottle change mode	Options <ul style="list-style-type: none"> <li>■ Number of samples</li> <li>■ Time</li> </ul> <b>Factory setting</b> Number of samples	The bottle is changed either after a specific number of samples or after a time.
If Bottle change mode <b>Number of samples</b> is selected:		
Samples per bottle	1 to 9999  <b>Factory setting</b> 1	Set the number of samples.
If Bottle change mode <b>Time</b> is selected:		
Time interval	00-00:02 to 31-00:00 DD-HH:MM  <b>Factory setting</b> 00-01:00 DD-HH:MM	Set the time (in days, hours and minutes) after which the system should change to the next bottle.
Multiple bottles	0 to 23  The configuration options depend on the current number of bottles  <b>Factory setting</b> 0	Multiple bottles: "Simultaneous" transfer of two samples to separate bottles.



**Path: Menu/Setup/Sampling programs/Setup program/New/Basic**

Function	Options	Info
Start condition	Options <ul style="list-style-type: none"> <li>■ Immediate</li> <li>■ Date/time</li> </ul> <b>Factory setting</b> Immediate	The sampling program can be started either immediately or at a specific, configurable time.
If Start condition <b>Date/time</b> is selected:		
Start date	01.01.2000 to 31.12.2099 <b>Factory setting</b> DD.MM.YYYY	Set the start date for the sampling program. The format depends on the option configured under general settings.
Start time	00:00:00 to 23:59:59 <b>Factory setting</b> HH:MM:SS (24h)	Set the time when the sampling program is started. The format depends on the option configured under general settings.
Stop condition	Options <ul style="list-style-type: none"> <li>■ Program end</li> <li>■ Continuous</li> </ul> <b>Factory setting</b> Program end	<b>Program end:</b> The device stops sampling automatically once it has run through the set program.  <b>Continuous:</b> The device runs through the set program continuously in an infinite loop. Do not forget to empty the bottles.
Assignment bin. output	Options <ul style="list-style-type: none"> <li>■ No binary output config. for state reporting</li> <li>■ Binary output S:x</li> </ul> <b>Factory setting</b> No binary output config. for state reporting	Assignment of the binary output to the program cycle.

### 4.3 Program types: Standard and Advanced

A Standard program can comprise a maximum of 5 subprograms. An Advanced program can comprise a maximum of 24 subprograms. These subprograms can be run simultaneously or consecutively.

Each event subprogram can consist of up to 3 conditions.

As the device contains dual bottle trays, you can assign a program easily, and easily detect a change in the program.

#### 4.3.1 Settings for the Standard program

Path: Menu/Setup/Sampling programs

Function	Options	Info
▶ Setup program		
New		A list of all the programs created is displayed. For this reason, it is often helpful to add an "S" for Standard in the program name.
▶ Standard		
Program name	Customized text	Use a distinct name for your sampling program. The program name can be up to 16 characters long.
Bottle configuration	Choice of all possible bottle combinations	The ordered bottle configuration is preset or the configuration selected in the setup is displayed.
Bottle volume	0 to 100000 ml <b>Factory setting</b> 30000 ml	Set the bottle volume. The preset value depends on the bottle configuration configured. The bottle volume is always 30 l for individual containers.  In the case of asymmetric distribution, e.g. $6 \times 3 \text{ l} + 2 \times 13 \text{ l}$ , you can set the bottle volume on the left and right in the menu items that follow.
Start condition	Options <ul style="list-style-type: none"> <li>■ Immediate</li> <li>■ Date/time</li> <li>■ Volume</li> </ul> <b>Factory setting</b> Immediate	The sampling program can be started either immediately, at a specific, configurable time, or when a certain totalized flow is reached.
If Start condition <b>Date/time</b> is selected:		
Start date	01.01.2000 to 31.12.2099 <b>Factory setting</b> DD.MM.YYYY	Set the start date for the sampling program. The format depends on the option configured under general settings.
Start time	00:00:00 to 23:59:59 <b>Factory setting</b> HH:MM:SS (24h)	Set the time when the sampling program is started. The format depends on the option configured under general settings.

## Path: Menu/Setup/Sampling programs

Function	Options	Info
If Start condition <b>Volume</b> is selected:		
Start volume input	Options <ul style="list-style-type: none"> <li>■ No flow input configured</li> <li>■ Binary input S:x</li> <li>■ Current input S:x</li> </ul> <b>Factory setting</b> No flow input configured	Select the start volume input. The binary input or the current input must be configured for this function. Only the inputs configured for flow measurement are displayed.
Start flow sum	1.000 to 9999.000 m <sup>3</sup> <b>Factory setting</b> 10.000 m <sup>3</sup>	Set the start volume.
If Stop condition <b>Date/time</b> is selected:		
Stop condition	Options <ul style="list-style-type: none"> <li>■ Program end</li> <li>■ Continuous</li> <li>■ Date/time</li> </ul> <b>Factory setting</b> Program end	<b>Program end:</b> The device stops sampling automatically once it has run through the set program. All the assigned bottles are filled. <b>Continuous:</b> The device runs through the set program continuously in an infinite loop. Do not forget to empty the bottles. <b>Date/time:</b> The device stops the set program at a specific time.
If Stop condition <b>Date/time</b> is selected:		
Stop date	01.01.2000 to 31.12.2099 <b>Factory setting</b> DD.MM.YYYY	Set the stop date for the sampling program. The format depends on the option configured under general settings.
Stop time	00:00:00 to 23:59:59 <b>Factory setting</b> HH:MM:SS (24h)	Set the time when the sampling program is stopped. The format depends on the option configured under general settings.
▶ Setup subprogram		
New		
Programpart		Use a distinct name for your subprogram. The program name can be up to 16 characters long.
Sampling mode	Options <ul style="list-style-type: none"> <li>■ Time paced CTCV</li> <li>■ Flow paced VTCV</li> <li>■ Time/flow paced CTVV</li> </ul> <b>Factory setting</b> Time paced CTCV	<b>Time paced CTCV:</b> A constant sampling volume is taken at steady intervals. <b>Flow paced VTCV:</b> A constant sampling volume is taken at variable intervals. <b>Time/flow paced CTVV(only for version with peristaltic pump):</b> A variable sampling volume is taken at steady intervals.
 The settings that depend on the sampling mode are listed in the "Program type: Basic" section.		



**Path: Menu/Setup/Sampling programs**

Function	Options	Info
Enable subprogram	<p>Options</p> <ul style="list-style-type: none"> <li>■ Immediate</li> <li>■ Individual dates</li> <li>■ Repeating date</li> <li>■ Interval</li> <li>■ Deactivation</li> </ul> <p><b>Factory setting</b> Immediate</p>	<p><b>Immediate:</b> The subprogram is enabled immediately.</p> <p><b>Individual dates:</b> Set the start and stop dates for enabling the subprogram.</p> <p><b>Repeating date:</b> Set the start condition, activity time and repetition interval for the subprogram.</p> <p><b>Interval:</b> Set the start condition, activity time and inactivity time for the subprogram.</p> <p><b>Deactivation:</b> Only visible if there is more than one subprogram</p>
If Enable subprogram <b>Individual dates</b> is selected:		
<p>▶ Individual dates</p> <p>Set the start and stop times for the subprogram. Enter a new date via "INSERT". Delete a date via "DELETE". You can assign a maximum of 25 start and stop dates.</p>		
If Enable subprogram <b>Repeating date</b> is selected:		
Start condition	<p>Options</p> <ul style="list-style-type: none"> <li>■ No delay</li> <li>■ Date/Time</li> <li>■ Time</li> </ul> <p><b>Factory setting</b> No delay</p>	<p><b>No delay:</b> The subprogram is started when the program is enabled.</p> <p><b>Date/Time:</b> Set the start date and start time for enabling the subprogram.</p> <p><b>Time:</b> Set the start time for enabling the subprogram.</p>
Activity time	<p>00:01 to 99:59 HH:MM</p> <p><b>Factory setting</b> 00:01 HH:MM</p>	<p>Specify how long the subprogram should be active in hours and minutes. The time to be selected depends on the setting for the repetition mode.</p>
▶ Multiple date		
Repetition mode	<p>Options</p> <ul style="list-style-type: none"> <li>■ Daily interval</li> <li>■ Weekly interval</li> <li>■ Days of week</li> </ul> <p><b>Factory setting</b> Daily interval</p>	<p><b>Daily interval:</b> Specify whether the subprogram should be repeated every day.</p> <p><b>Weekly interval:</b> Specify whether the subprogram should be repeated every week.</p> <p><b>Days of week:</b> Specify whether the subprogram should be repeated on certain days of the week. -&gt; Select the days of the week in the subsequent menu item.</p>

**Path: Menu/Setup/Sampling programs**

Function	Options	Info
Repetition interval (only for Daily interval and Weekly interval)	1 to 999 <b>Factory setting</b> 1	Specify for how many days or weeks the subprogram should be active. Example: Repetition mode = daily interval Repetition interval = 2 The subprogram is enabled every second day from the start condition.
If Enable subprogram <b>Interval</b> is selected:		
Start condition	Options <ul style="list-style-type: none"> <li>■ No delay</li> <li>■ Date/Time</li> <li>■ Time</li> </ul> <b>Factory setting</b> Date/Time	<b>No delay:</b> The subprogram is started when the program is enabled. <b>Date/Time:</b> Set the start date and start time for enabling the subprogram. <b>Time:</b> Set the start time for enabling the subprogram.
Start date	01.01.2000 to 31.12.2099 <b>Factory setting</b> DD.MM.YYYY	Set the start date for the 1st interval. The format depends on the option configured under general settings.
Start time	00:00:00 to 23:59:59 <b>Factory setting</b> HH:MM:SS (24h)	Set the time for the 1st interval. The format depends on the option configured under general settings.
Activity time	00-00:01 to 31-00:00 DD-HH:MM <b>Factory setting</b> 00-00:01 DD-HH:MM	Specify how long the subprogram should be active in days, hours and minutes. The subprogram always begins with an activation.
Inactivity time	00-00:01 to 31-00:00 DD-HH:MM <b>Factory setting</b> 00-00:01 DD-HH:MM	Specify how long the subprogram should be inactive in days, hours and minutes.
Sample at enable	Options <ul style="list-style-type: none"> <li>■ No</li> <li>■ Yes</li> </ul> <b>Factory setting</b> Yes	Specify whether the first sample should be taken directly when the subprogram is enabled. For example, with intervals, a sample is taken at the start of every activation interval.
Sample at disable	Options <ul style="list-style-type: none"> <li>■ No</li> <li>■ Yes</li> </ul> <b>Factory setting</b> No	Specify whether a sample should be taken when the subprogram is disabled. For example, with intervals, a sample is taken at the end of every activation interval.

**Path: Menu/Setup/Sampling programs**

Function	Options	Info
<p>New bottle at disable</p>	<p>Options</p> <ul style="list-style-type: none"> <li>■ No</li> <li>■ Yes</li> </ul> <p><b>Factory setting</b> Yes</p>	
<p>Bottle synchronization</p>	<p>Options</p> <ul style="list-style-type: none"> <li>■ None</li> <li>■ 1. bottle change time</li> <li>■ 1. Time of change + bottle number</li> <li>■ External BC sync input</li> </ul> <p><b>Factory setting</b> None</p>	<p>Specific bottles can be assigned specific filling times with the bottle synchronization function. For example, bottle 1 is to be filled from midnight to 2 a.m., bottle 2 from 2 a.m. to 4 a.m. etc..</p> <p><b>None</b> The time of sampling and bottle change are not synchronized.</p> <p><b>1. bottle change time</b> Sampling starts with the first bottle. The changeover to the next bottles is synchronized.</p> <p><b>1. Time of change + bottle number</b> A specific fill time is assigned to each bottle.</p> <p><b>External BC sync input</b> The system changes to the next bottle when an external signal is received. The external signal first has to be configured via the binary input. The binary input can then be selected as the source.</p>
<p>Assignment bin. output</p>	<p>Options</p> <ul style="list-style-type: none"> <li>■ No binary output config. for state reporting</li> <li>■ Binary output S:x</li> </ul> <p><b>Factory setting</b> No binary output config. for state reporting</p>	<p>Assignment of the binary output to the program cycle.</p>
<p>Use "SAVE" to save the subprogram setup. Then press "ESC" to return to the main program. A prompt to save the program appears if you have not yet saved the subprogram. You can avoid saving the program by pressing "ESC".</p>		
<p>Bottle assignment (only possible with multiple bottles)</p> <p> This menu item appears when more than one bottle is available, regardless of the number of subprograms.</p>	<p>Options</p> <ul style="list-style-type: none"> <li>■ No bottle assignment</li> <li>■ Dynamical bottle assignment</li> <li>■ Statical bottle assignment</li> </ul> <p><b>Factory setting</b> Dynamical bottle assignment</p>	<p><b>No bottle assignment:</b> Each subprogram fills the same bottle until the bottle is full. All the subprograms then change to the next bottle. Only visible if there is more than one subprogram.</p> <p><b>Dynamical bottle assignment:</b> When the subprogram changes, the system switches to the next empty bottle.</p> <p><b>Statical bottle assignment:</b> A table can be used to assign a subprogram to each bottle.</p>
<p> Via the "Bottle change" menu item, the bottle change can be configured after a certain time or number of samples if bottle distribution with more than one bottle has been selected and either dynamic or static bottle assignment has been selected.</p>		

---

**Path: Menu/Setup/Sampling programs**

Function	Options	Info
If Bottle assignment <b>Statical bottle assignment</b> is selected:		
<p>▶ Bottle assignment table</p> <p>Select a bottle and assign it a subprogram.</p>		

### 4.3.2 Programming example: Program switchover

The following example explains how to program a program change with flow-paced sampling as the daily average sample from Monday to Friday and time-paced sampling to a composite container on Saturday and Sunday.

**Path: Menu/Setup/Sampling programs/Setup program/New**

Function	Entry for sample program
▶ Standard	
Program name	TDVT 6+20
Bottle configuration	6x + 1x
Bottle volume left	3000 ml
Bottle volume right	20000 ml
Start condition	Date/time
Start date	DD.MM.YYYY e.g. 03.06.2010
Start time	HH:MM:SS e.g. 12:00:00
Stop condition	Continuous
▶ Setup subprogram	
Programpart	MO - FR
"SAVE" - saves the "MO - FR" subprogram	
▶ Setup subprogram	
Programpart	SAT - SUN
"SAVE" - saves the "SAT - SUN" subprogram	
"ESC" - the main program is displayed	
Bottle assignment	Statical bottle assignment
▶ Setup subprogram: MO - FR	
▶ Edit	
Sampling mode	Flow paced VTCV
Flowmeter input	Current input S:1
Sampling interval	1000 m <sup>3</sup>
Sampling volume	80 ml
Bottle change mode	Time
Time interval	04:00
Multiple bottles	0
Enable subprogram	Multiple date



## Path: Menu/Setup/Sampling programs/Setup program/New

Function	Entry for sample program
Start condition	No delay
Activity time	24:00
▶ Repeating date	
Repetition mode	Days of week
Monday	Yes
Tuesday	Yes
Wednesday	Yes
Thursday	Yes
Friday	Yes
Saturday	No
Sunday	No
Sample at enable	Yes
Sample at disable	No
"SAVE" - saves the "MO - FR" subprogram	
"ESC" - "ESC"	
▶ Setup subprogram: SAT - SUN	
▶ Edit	
Sampling mode	Time paced CTCV
Sampling interval	15 min
Sampling volume	100 ml
Bottle change mode	Time
Time interval	48:00
Multiple bottles	0
Enable subprogram	Multiple date
Start condition	No delay
Activity time	24:00
▶ Repeating date	
Repetition mode	Days of week
Monday	No
Tuesday	No
Wednesday	No

**Path: Menu/Setup/Sampling programs/Setup program/New**

Function	Entry for sample program
Thursday	No
Friday	No
Saturday	Yes
Sunday	Yes
Sample at enable	Yes
Sample at disable	No
"SAVE" - saves the "SAT - SUN" subprogram	
"ESC" - "ESC"	
▶ Bottle assignment table	
Bottle 1 ... Bottle 6	MO - FR
Bottle 7	SAT - SUN

Press the "SAVE" soft key to save the program. In the overview, you can start the program created under "Select sampling program".

### 4.3.3 Settings for the Advanced program

Path: Menu/Setup/Sampling programs

Function	Options	Info
▶ Setup program		
New		A list of all the programs created is displayed. For this reason, it is often helpful to add an "A" for Advanced in the program name.
▶ Advanced		
Program name	Customized text	Use a distinct name for your sampling program. The program name can be up to 16 characters long.
Bottle configuration	Choice of all possible bottle combinations	The ordered bottle configuration is preset or the configuration selected in the setup is displayed.
Bottle volume	10 to 100000 ml <b>Factory setting</b> 30000 ml	Set the bottle volume. The preset value depends on the bottle configuration configured. The bottle volume is always 30 l for individual containers.  In the case of asymmetric distribution, e.g. 6 x 3 l + 2 x 13 l, you can set the bottle volume on the left and right in the menu items that follow.
Start condition	Options <ul style="list-style-type: none"> <li>■ Immediate</li> <li>■ Date/time</li> <li>■ Volume</li> <li>■ External start</li> <li>■ External duration</li> <li>■ Fieldbus(optional)</li> </ul> <b>Factory setting</b> Immediate	<b>Immediate</b> The sampling program is started immediately. <b>Date/time</b> The sampling program is started at a specific time that can be configured. <b>Volume</b> The sampling program is started when a certain totalized flow is reached. <b>External start</b> The sampling program is started by a pulse at the configured binary input. <b>External duration</b> The sampling program is active as long as the configured input has the corresponding level. <b>Fieldbus(optional):</b> The sampling program is started by a signal from the control system.
If Start condition <b>Date/time</b> is selected:		
Start date	01.01.2000 to 31.12.2099 <b>Factory setting</b> DD.MM.YYYY	Set the start date for the sampling program. The format depends on the option configured under general settings.
Start time	00:00:00 to 23:59:59 <b>Factory setting</b> HH:MM:SS (24h)	Set the time when the sampling program is started. The format depends on the option configured under general settings.



**Path: Menu/Setup/Sampling programs**

Function	Options	Info
If Start condition <b>Volume</b> is selected:		
Start volume input	Options <ul style="list-style-type: none"> <li>■ No flow input configured</li> <li>■ Binary input S:x</li> <li>■ Current input S:x</li> </ul> <b>Factory setting</b> No flow input configured	Select the start volume input. The binary input or the current input must be configured for this function. Only the inputs configured for flow measurement are displayed.
Start flow sum	1.000 to 9999.000 m <sup>3</sup>  <b>Factory setting</b> 10.000 m <sup>3</sup>	Set the start volume.
If Start condition <b>External start</b> is selected:		
Start signal input	Options <ul style="list-style-type: none"> <li>■ No program start input configured</li> <li>■ Binary input S:x</li> </ul> <b>Factory setting</b> No program start input configured	Select the program start input. The binary input must be configured for this function. Only the inputs configured as a program start input are displayed.
If Start condition <b>External duration</b> is selected:		
Start signal input	Options <ul style="list-style-type: none"> <li>■ No program duration input configured</li> <li>■ Binary input S:x</li> </ul> <b>Factory setting</b> No program duration input configured	Select the program duration input. The binary input must be configured for this function. Only the inputs configured as a program duration input are displayed.
If Start condition <b>Profibus DP</b> or <b>Modbus</b> is selected:		
Start signal input	Options <ul style="list-style-type: none"> <li>■ None</li> <li>■ DO 01 (Digital Output)</li> <li>■ DO 02 (Digital Output)</li> <li>■ DO 03 (Digital Output)</li> <li>■ DO 04 (Digital Output)</li> <li>■ DO 05 (Digital Output)</li> <li>■ DO 06 (Digital Output)</li> <li>■ DO 07 (Digital Output)</li> <li>■ DO 08 (Digital Output)</li> </ul> <b>Factory setting</b> None	Select the program start input.

## Path: Menu/Setup/Sampling programs

Function	Options	Info
Stop condition (not for External start)	Options <ul style="list-style-type: none"> <li>■ Program end</li> <li>■ Continuous</li> <li>■ Date/time</li> <li>■ External signal</li> <li>■ Fieldbus(optional)</li> </ul> <b>Factory setting</b> Program end	<b>Program end:</b> The device stops sampling automatically once it has run through the set program.  <b>Continuous:</b> The device runs through the set program continuously in an infinite loop. Do not forget to empty the bottles.  <b>Date/time:</b> The device stops the set program at a specific time.  <b>External signal:</b> The device stops the set program if a pulse is sent to a binary input configured accordingly.  <b>Fieldbus:</b> The sampling program is stopped by a signal from the control system.
If Stop condition <b>Date/time</b> is selected:		
Stop date	01.01.2000 to 31.12.2099 <b>Factory setting</b> DD.MM.YYYY	Set the stop date for the sampling program. The format depends on the option configured under general settings.
Stop time	00:00:00 to 23:59:59 <b>Factory setting</b> HH:MM:SS (24h)	Set the time when the sampling program is stopped. The format depends on the option configured under general settings.
If Stop condition <b>External signal</b> is selected:		
Stop signal input	Options <ul style="list-style-type: none"> <li>■ No program stop input configured</li> <li>■ Binary input S:x</li> </ul> <b>Factory setting</b> No program stop input configured	Select the program stop input. The binary input must be configured for this function. Only the inputs configured as a program stop input are displayed.
If Stop condition <b>Profibus DP</b> or <b>Modbus</b> is selected:		
Stop signal input	Options <ul style="list-style-type: none"> <li>■ None</li> <li>■ DO 01 (Digital Output)</li> <li>■ DO 02 (Digital Output)</li> <li>■ DO 03 (Digital Output)</li> <li>■ DO 04 (Digital Output)</li> <li>■ DO 05 (Digital Output)</li> <li>■ DO 06 (Digital Output)</li> <li>■ DO 07 (Digital Output)</li> <li>■ DO 08 (Digital Output)</li> </ul> <b>Factory setting</b> None	Select the program stop input.
▶ Setup subprogram		
New		

**Path: Menu/Setup/Sampling programs**

Function	Options	Info
Programpart		Use a distinct name for your subprogram. The program name can be up to 16 characters long.
Sampling mode	<p>Options</p> <ul style="list-style-type: none"> <li>■ Time paced CTCV</li> <li>■ Flow paced VTCV</li> <li>■ Time/flow paced CTVV</li> <li>■ Single sample</li> <li>■ Sampling table</li> <li>■ External signal</li> <li>■ Fieldbus(optional)</li> </ul> <p><b>Factory setting</b> Time paced CTCV</p>	<p><b>Time paced CTCV:</b> A constant sampling volume is taken at steady intervals.</p> <p><b>Flow paced VTCV:</b> A constant sampling volume is taken at variable intervals.</p> <p><b>Time/flow paced CTVV (only for version with peristaltic pump):</b> A variable sampling volume is taken at steady intervals.</p> <p><b>Single sample:</b> The device takes a single sample with a specific volume.</p> <p><b>Sampling table:</b> The time and the sampling volume is assigned to a certain bottle in the sampling table.</p> <p><b>External signal:</b> A sample is taken when an external signal is received.</p> <p><b>Fieldbus:</b> The sampling cycle is triggered via the control system.</p>
<p> The settings that depend on the sampling mode (time-paced, flow-paced and time/flow-paced sampling) are listed in the "Program type: Basic" section.</p>		
<p>If Sampling mode <b>Single sample</b> is selected:</p>		
<p>Dosing volume (for version with vacuum pump or sampling assembly) Sampling volume (for version with peristaltic pump)</p>	<p>Vacuum pump: 20 to 350 ml</p> <p>Peristaltic pump: 10 to 10000 ml or maximum bottle volume</p> <p>Sampling assembly: 10, 30, 50 ml</p> <p><b>Factory setting</b> Vacuum pump: 200 ml Peristaltic pump: 100 ml Sampling assembly: 10 ml</p>	<p>Depending on the version, set the dosing volume or the sampling volume.</p> <p> The volume is taken from the setup in the version with a vacuum pump or sampling assembly.</p> <p> The dosing accuracy and the repeatability of a sample volume &lt; 20 ml can vary, depending on the specific application.</p>
<p>If Sampling mode <b>Sampling table</b> is selected:</p>		
<p>▶ Sampling table</p> <p>Assign the time and sampling volume to a certain bottle. Add a new entry via "INSERT". Delete an entry via "DELETE". You can make a maximum of 24 entries.</p>		

## Path: Menu/Setup/Sampling programs

Function	Options	Info
<p><b>Example:</b></p> <ul style="list-style-type: none"> <li>- Bottle: 1</li> <li>- Bottle: 2</li> <li>...</li> </ul> <p>1st sampling one hour after program start: 100 ml in bottle 1 2nd sampling 10 minutes later: 100 ml in bottle 2</p> <p>The sampling table indicates: After the defined "Delta time" (column 2) the volume of column 3 will be dosed into the bottle of column 1.</p>	<ul style="list-style-type: none"> <li>- Delta (=waiting time): 01:00:00</li> <li>- Delta (=waiting time): 00:10:00</li> </ul>	<ul style="list-style-type: none"> <li>- Volume: 100 ml</li> <li>- Volume: 100 ml</li> </ul>
If Sampling mode <b>External signal</b> is selected:		
Sampling signal input	<p>Options</p> <ul style="list-style-type: none"> <li>■ No sampling input configured</li> <li>■ Binary input S:x</li> </ul> <p><b>Factory setting</b> No sampling input configured</p>	Select the input for the sampling signal. The binary input must be configured for this function. Only the configured inputs are displayed.
If Sampling mode <b>Profibus DP</b> or <b>Modbus</b> is selected:		
Sampling signal input	<p>Options</p> <ul style="list-style-type: none"> <li>■ None</li> <li>■ DO 01 (Digital Output)</li> <li>■ DO 02 (Digital Output)</li> <li>■ DO 03 (Digital Output)</li> <li>■ DO 04 (Digital Output)</li> <li>■ DO 05 (Digital Output)</li> <li>■ DO 06 (Digital Output)</li> <li>■ DO 07 (Digital Output)</li> <li>■ DO 08 (Digital Output)</li> </ul> <p><b>Factory setting</b> None</p>	Select the input for the sampling signal. The fieldbus must be configured for this function.
<p>Change signal</p>  This item only appears if bottle changeover is set to fieldbus.	<p>Options</p> <ul style="list-style-type: none"> <li>■ None</li> <li>■ DO 01 (Digital Output)</li> <li>■ DO 02 (Digital Output)</li> <li>■ DO 03 (Digital Output)</li> <li>■ DO 04 (Digital Output)</li> <li>■ DO 05 (Digital Output)</li> <li>■ DO 06 (Digital Output)</li> <li>■ DO 07 (Digital Output)</li> <li>■ DO 08 (Digital Output)</li> </ul> <p><b>Factory setting</b> None</p>	Select the input for the bottle change signal.

**Path: Menu/Setup/Sampling programs**

Function	Options	Info
Enable subprogram	<p>Options</p> <ul style="list-style-type: none"> <li>■ Immediate</li> <li>■ Individual dates</li> <li>■ Repeating date</li> <li>■ Interval</li> <li>■ Event</li> <li>■ External start</li> <li>■ Deactivation</li> <li>■ Fieldbus(optional)</li> </ul> <p><b>Factory setting</b> Immediate</p>	<p><b>Immediate:</b> The subprogram is enabled immediately.</p> <p><b>Individual dates:</b> Set the start and stop dates for enabling the subprogram.</p> <p><b>Repeating date:</b> Set the start condition, activity time and repetition interval for the subprogram.</p> <p><b>Interval:</b> Set the start condition, activity time and inactivity time for the subprogram.</p> <p><b>Event:</b> The subprogram is enabled by an event. Up to 3 measuring signals are linked to form a start signal using And/Or logic.</p> <p><b>External start:</b> The subprogram is enabled by a pulse at a binary input configured accordingly.</p> <p><b>Deactivation:</b> Subprogram 2 or 2+n is started as soon as subprogram 1 is disabled. (Only possible with multiple subprograms)</p> <p><b>Fieldbus:</b> The subprogram is enabled by a signal from the control system.</p>

 The settings (Immediate, Individual dates, Repeating date and Interval) that depend on the activation of the subprogram are listed in the "Program type: Standard" section.

If Enable subprogram **Event** is selected:

Start condition	<p>Options</p> <ul style="list-style-type: none"> <li>■ No delay</li> <li>■ Date/Time</li> <li>■ Time</li> </ul> <p><b>Factory setting</b> No delay</p>	<p><b>No delay:</b> The subprogram is started when the program is enabled.</p> <p><b>Date/Time:</b> Set the start date and start time for enabling the subprogram.</p> <p><b>Time:</b> Set the start time for enabling the subprogram.</p>
-----------------	---	--

► Activation event

Number of events	<p>Options</p> <ul style="list-style-type: none"> <li>■ 1</li> <li>■ 2</li> <li>■ 3</li> </ul> <p><b>Factory setting</b> 1</p>	Specify how many measuring inputs (1-3) you want to link to generate an activation signal.
------------------	--	--

► Event Editor 1

 If you have more than one event editor, the "Event editor" menu item appears often. Use the "Link" menu item to configure the logical link between the signals.



## Path: Menu/Setup/Sampling programs

Function	Options	Info
Source of data	Options <ul style="list-style-type: none"> <li>■ None</li> <li>■ Binary input S:x</li> <li>■ Current input S:x</li> <li>■ Temperature input</li> <li>■ Fieldbus</li> </ul> (depending on the version and sensor) <b>Factory setting</b> None	Select the input via which the activation event is to be output. The inputs are configured in the "Setup/Inputs" menu. The binary inputs are only visible if they have been configured accordingly (rainfall or flow).
Measured value	Options (depends on sensor/data source) <ul style="list-style-type: none"> <li>■ None</li> <li>■ Totalized flow</li> <li>■ AO 01 (Analog Output)</li> <li>■ AO 02 (Analog Output)</li> <li>■ AO 03 (Analog Output)</li> <li>■ AO 04 (Analog Output)</li> <li>■ DO 01 (Digital Output)</li> <li>■ DO 02 (Digital Output)</li> <li>■ DO 03 (Digital Output)</li> <li>■ DO 04 (Digital Output)</li> <li>■ DO 05 (Digital Output)</li> <li>■ DO 06 (Digital Output)</li> <li>■ DO 07 (Digital Output)</li> <li>■ DO 08 (Digital Output)</li> </ul> <b>Factory setting</b> None	
Operating mode	Options <ul style="list-style-type: none"> <li>■ Upper limit</li> <li>■ Lower limit</li> <li>■ Within range</li> <li>■ Out of range</li> <li>■ Rate of change</li> </ul> <b>Factory setting</b> Upper limit	Type of limit value monitoring: <ul style="list-style-type: none"> <li>■ Limit value overshoot or undershoot</li> <li>■ Measured value within or outside a range</li> <li>■ Rate of change</li> </ul>
Limit value	<b>Range of adjustment and factory setting</b> Depends on the measured value	<i>Operating mode= "Above limit check" or "Below limit check"</i> <ul style="list-style-type: none"> <li>■ The event is triggered if the limit value + hysteresis is exceeded for the switch-on duration.</li> <li>■ The event is reset again if the limit value - hysteresis is undershot for the duration of the switch-off delay at least.</li> </ul>
Range lower value	<b>Range of adjustment and factory setting</b> Depends on the measured value	<i>Operating mode= "In range check" or "Out of range check"</i> <ul style="list-style-type: none"> <li>■ The event is triggered if the range lower value + hysteresis is exceeded for the switch-on duration.</li> <li>■ The event is reset again if the range upper value - hysteresis is undershot for the duration of the switch-off delay at least.</li> </ul>
Range upper value		



**Path: Menu/Setup/Sampling programs**

Function	Options	Info
Hysteresis	<b>Range of adjustment and factory setting</b> Depends on the measured value	The hysteresis is the difference between the switch-on point and the switch-off point if values, which cause the limit switch to pick up, become closer or move further apart. It is needed to ensure a stable switching behavior.
Start delay	0 to 9999 s	Synonyms: pick-up and drop-out delay
Switch off delay	<b>Factory setting</b> 0 s	
Delta value	<b>Range of adjustment and factory setting</b> Depends on the measured value	<i>Operating mode="Change rate"</i>  The event is triggered if the measured value changes by at least the delta value (both positive and negative) within the set delta time. The event is deleted as soon as the rate of change is lower than the set value and the auto confirmation time has elapsed.
Delta time	00:01 to 23:59 <b>Factory setting</b> 01:00	
Auto Confirm	00:01 to 23:59 <b>Factory setting</b> 00:01	
If Enable subprogram <b>External start</b> is selected:		
Activation input	Options <ul style="list-style-type: none"> <li>■ No program part start input configured</li> <li>■ Binary input S:x</li> </ul> <b>Factory setting</b> No program part start input configured	Select the input for start of the subprogram. The binary input must be configured for this function. Only the configured inputs are displayed.
If Enable subprogram <b>Profibus DP</b> or <b>Modbus</b> is selected:		
Activation signal	Options <ul style="list-style-type: none"> <li>■ None</li> <li>■ DO 01 (Digital Output)</li> <li>■ DO 02 (Digital Output)</li> <li>■ DO 03 (Digital Output)</li> <li>■ DO 04 (Digital Output)</li> <li>■ DO 05 (Digital Output)</li> <li>■ DO 06 (Digital Output)</li> <li>■ DO 07 (Digital Output)</li> <li>■ DO 08 (Digital Output)</li> </ul> <b>Factory setting</b> None	Enable subprogram via fieldbus.
Sample at enable (not for single sample and sampling table)	Options <ul style="list-style-type: none"> <li>■ No</li> <li>■ Yes</li> </ul> <b>Factory setting</b> Yes	Specify whether the first sample should be taken directly when the subprogram is enabled.

## Path: Menu/Setup/Sampling programs

Function	Options	Info
Sample at disable (not for single sample and sampling table and also not for "Immediate" and event)	Options <ul style="list-style-type: none"> <li>■ No</li> <li>■ Yes</li> </ul> <b>Factory setting</b> No	Specify whether a sample should be taken when the subprogram is disabled.
Deactivation	Options <ul style="list-style-type: none"> <li>■ Bottles full</li> <li>■ Enable invalid</li> <li>■ Deactivation with event</li> </ul> <b>Factory setting</b> Enable invalid	Select the disable function of the subprogram: <b>Bottles full</b> The subprogram is disabled once all the assigned bottles have been filled. <b>Enable invalid</b> Disable via limit value <b>Deactivation with event</b> New parameter can be defined
Bottle change mode	Options <ul style="list-style-type: none"> <li>■ No</li> <li>■ Yes</li> </ul> <b>Factory setting</b> Yes	<b>No:</b> The bottle is changed following a disable/enable <b>Yes:</b> When the cycle is finished, the system continues filling the last bottle.
Synchronize samplings	Options <ul style="list-style-type: none"> <li>■ To subprogram start</li> <li>■ To clock</li> </ul> <b>Factory setting</b> To subprogram start	<b>To subprogram start</b> The intervals defined in the sampling mode are enabled when the subprogram is started. <b>To clock</b> The intervals defined in the sampling mode are enabled after a specific time. For example, if 30 min is entered this means that the interval is only activated at a time of xx:30. → You configure this time in the "Offset synchronization" menu item.
Bottle synchronization	Options <ul style="list-style-type: none"> <li>■ None</li> <li>■ 1. bottle change time</li> <li>■ 1. Time of change + bottle number</li> <li>■ External BC sync input</li> </ul> <b>Factory setting</b> None	Specific bottles can be assigned specific filling times with the bottle synchronization function. For example, bottle 1 is to be filled from midnight to 2 a.m., bottle 2 from 2 a.m. to 4 a.m. etc.. <b>None</b> The time of sampling and bottle change are not synchronized. <b>1. bottle change time</b> Sampling starts with the first bottle. The changeover to the next bottles is synchronized. <b>1. Time of change + bottle number</b> A specific fill time is assigned to each bottle. <b>External BC sync input</b> The system changes to the next bottle when an external signal is received. The external signal first has to be configured via the binary input. The binary input can then be selected as the source.

**Path: Menu/Setup/Sampling programs**

Function	Options	Info
Assignment bin. output	Options <ul style="list-style-type: none"> <li>■ No binary output config. for state reporting</li> <li>■ Binary output S:x</li> </ul> <b>Factory setting</b> No binary output config. for state reporting	Assignment of the binary output to the program cycle.
Use "SAVE" to save the subprogram setup. Then press "ESC" to return to the main program.		
Bottle assignment (only possible with multiple bottles)  This menu item does not appear unless 2 or more bottles are available.	Options <ul style="list-style-type: none"> <li>■ No bottle assignment</li> <li>■ Dynamical bottle assignment</li> <li>■ Statical bottle assignment</li> </ul> <b>Factory setting</b> No bottle assignment	<b>No bottle assignment:</b> Each subprogram fills the same bottle until the bottle is full. All the subprograms then change to the next bottle.  <b>Dynamical bottle assignment:</b> When the subprogram changes, the system switches to the next bottle.  <b>Statical bottle assignment:</b> A table can be used to assign a subprogram to each bottle.
 Via the "Bottle change" menu item, the bottle change can be configured after a certain time or number of samples if more than 1 subprogram is available and either dynamic or static bottle assignment has been selected.		
If Bottle assignment <b>Statical bottle assignment</b> is selected:		
<p>▶ Bottle assignment table</p> <p>Select a bottle and assign it a subprogram.</p>		

### 4.3.4 Programming example: Event program

Event-controlled sampling is only possible for the version with digital sensors with Memosens technology. The following example explains how to program an event program with time-paced sampling into a composite container and time-paced sampling into individual bottles. The composite container is emptied daily.

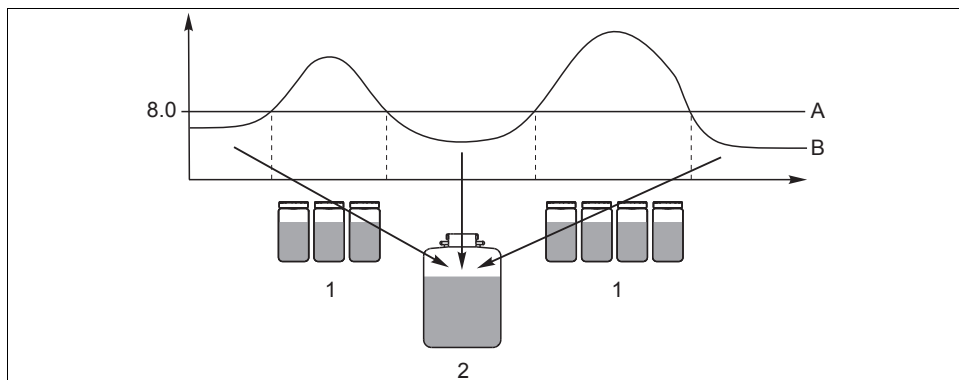

Fig. 8: Event-controlled sampling

- A pH value: 8.0  
 B pH value  
 1 Sampling into individual bottles when pH value > 8.0  
 2 Sampling into composite container when pH value < 8.0

a0014120s

Path: Menu/Setup/Sampling programs/Setup program/New

Function	Entry for sample program
▶ Advanced	
Program name	TDTE 12+20
Bottle configuration	12x + 1x
Bottle volume left	1000 ml
Bottle volume right	2000 ml
Start condition	Immediate
Stop condition	Continuous
Bottle assignment	Static bottle assignment
▶ Setup subprogram: New	
Programpart	TD1
Sampling mode	Time paced CTCV
Sampling interval	15 min

## Path: Menu/Setup/Sampling programs/Setup program/New

Function	Entry for sample program
Sampling volume	100 ml
Multiple bottles	1
Enable subprogram	Immediate
Sample at enable	Yes
Synchronize samplings	To subprogram start
-> "SAVE" -> "ESC"	
▶ Setup subprogram: New	
Programpart	EE1
Sampling mode	Time paced CTCV
Sampling interval	6 min
Sampling volume	100 ml
Bottle change mode <i>Only if Bottle assignment = "Statical bottle assignment" is selected in the main program</i>	Number of samples
Samples per bottle	10
Multiple bottles	0
Enable subprogram	Event
Start condition	No delay
▶ Activation event	
Number of events	1
▶ Event Editor 1	
Source of data	CH1: 1:1 pH glass
Measured value	pH
Operating mode	Upper limit
Limit value	pH 8.00
Hysteresis	pH 0.20
Start delay	0 s
Switch off delay	0 s
Sample at enable	Yes
Sample at disable	No
Deactivation	Enable invalid

**Path: Menu/Setup/Sampling programs/Setup program/New**

Function	Entry for sample program
Synchronize samplings	To subprogram start
-> "SAVE" -> "ESC" -> "ESC"	
Bottle assignment	Statical bottle assignment
▶ Bottle assignment table	
Bottle 1 ... Bottle 12 Bottle 13	EE1  EE1 TD1
-> "ESC"	

Press the "SAVE" soft key to save the program. In the overview, you can start the program created under "Select sampling program".

**4.3.5 Programming example: Limit value-controlled program**

The following example explains how to program a limit value-controlled sampling program with flow-paced sampling into individual bottles above the limit value and time-paced sampling into individual bottles below the limit value. When the subprogram changes, the system switches to the next bottle.

**Path: Menu/Setup/Sampling programs/Setup program/New**

Function	Entry for sample program
▶ Advanced	
Program name	UVT 12x3
Bottle configuration	12x
Bottle volume	3000 ml
Start condition	Date/time
Start date	DD.MM.YYYY e.g. 03.06.2010
Start time	HH:MM:SS e.g. 12:00:00
Stop condition	Continuous
▶ Setup subprogram: New	
Programpart	VD1
"SAVE" - saves the "VD1" subprogram	
▶ Setup subprogram: New	
Programpart	ZD1

**Path: Menu/Setup/Sampling programs/Setup program/New**

Function	Entry for sample program
"SAVE" - saves the "ZD1" subprogram	
"ESC" - the main program is displayed	
Bottle assignment	Dynamical bottle assignment
▶ Setup subprogram: VD 1	
▶ Edit	
Sampling mode	Flow paced VTCV
Flowmeter input	Current input S:1 (max. 15 samples/h = 4 min)
Sampling interval	50 m <sup>3</sup>
Sampling volume	100 ml
Bottle change mode	Time
Time interval	06:00
Multiple bottles	0
Enable subprogram	External activation
Start condition	No delay
▶ Activation event	
Number of events	1
▶ Event Editor 1	
Source of data	Current input S:1
Measured value	Flow rate
Operating mode	Upper limit
Limit value	155 l/s
Hysteresis	5 l/s
Start delay	0 s
Switch off delay	0 s
"ESC" - "ESC"	
Sample at enable	Yes
Sample at disable	No
Stop condition	Enable invalid
Synchronize samplings	To subprogram start
"SAVE" - "ESC"	
▶ Setup subprogram: ZD 1	



## Path: Menu/Setup/Sampling programs/Setup program/New

Function	Entry for sample program
▶ Edit	
Sampling mode	Time paced CTCV
Sampling interval	15 min
Sampling volume	100 ml
Bottle change mode	Time
Time interval	06:00
Multiple bottles	0
Enable subprogram	Event
Start condition	No delay
▶ Activation event	
Number of events	1
▶ Event Editor 1	
Source of data	Current input S:1
Measured value	Flow rate
Operating mode	Lower limit
Limit value	150 l/s
Hysteresis	5 l/s
Start delay	0 s
Switch off delay	0 s
"ESC" - "ESC"	
Sample at enable	Yes
Sample at disable	No
Stop condition	Enable invalid
Synchronize samplings	To subprogram start
"SAVE" - "ESC"	

Press the "SAVE" soft key to save the program. In the overview, you can start the program created under "Select sampling program".

## 4.4 Executing the program

In the overview, you can see all the programs created under "Select sampling program". Here, you also have the possibility of creating a new program with "New". Using the navigator, you can select the program you want to execute here and then choose from the following items: "Edit", "Delete", "Start", "Duplicate or "Cancel".

**Path: Setup program**

Function	Info
▶ Edit	The selected program is displayed and can be edited. Press the "SAVE" key to save the changes.
▶ Delete	The selected program is deleted following a confirmation prompt.
▶ Start	The selected program is started immediately. The program can be canceled or paused by pressing the "OFF" key.  If there are differences between the setup and the selected program, the "Program configuration contains errors!" message appears, e.g. the bottle configuration in the program does not match the configuration in the setup. The program is not started. In this example, the actual bottle configuration must be checked against the configuration in the setup and the program and changed accordingly. Only the bottle configuration entered in the setup is valid for the program to be executed.
▶ Duplicate	The selected program is duplicated and saved with an ID.
▶ Cancel	Back to the overview.

The "Setup program" display contains the "ESC", "MAN", "?" and "OFF" soft keys.

**Path: Setup program**

Function	Info
▶ ESC	Back to the overview. Any program currently running is canceled.
▶ MAN	Manual sampling can be configured and started here. Any program currently running is paused. -> See BA00443C "Commissioning", Sampling program/Manual sampling section
▶ ?	A help text is displayed for the item.
▶ OFF	If no program is enabled, the device can be switched off here. If a program is enabled, the following options appear:  <b>Power down sampler:</b> Following a confirmation prompt, the device is set to the standby mode. Power continues to be supplied to the device and the LED flashes green.  <b>Stop program %0V:</b> Stops a program currently running following a confirmation prompt. The overview display appears.  <b>Pause program %0V:</b> Is selected if maintenance work is pending. The program is paused and the pause time is entered in the logbook. The current program is resumed when the "Resume program" button is pressed.

## 5 Outputs

### 5.1 Binary outputs

The basic version of the device always has two binary outputs.

Possible application

→ For outputting a manipulated variable to connected actuators

 The binary output must be assigned in the program or subprogram before it can be activated.

**Path: Menu/Setup/Outputs**

Function	Options	Info
▶ OutputBinary		
Function	Options <ul style="list-style-type: none"> <li>■ Off</li> <li>■ Event</li> <li>■ Limit value</li> <li>■ Diagnostics message</li> <li>■ Cleaning (only for version with sensors with the Memosens protocol)</li> </ul> <b>Factory setting</b> Off	The following functions depend on the option selected. Function = "Off" switches off the function of the binary output and means no further settings are required.   For Cleaning: The outputs can only switch 100mA. A relay must be added to control valves or motors.
If Function: <b>Event</b> is selected:		
Signal slope	Options <ul style="list-style-type: none"> <li>■ Low-High</li> <li>■ High-Low</li> </ul> <b>Factory setting</b> Low-High	Select the level change of the signal

**Path: Menu/Setup/Outputs**

Function	Options	Info
Event	Options <ul style="list-style-type: none"> <li>■ Program enabled</li> <li>■ End of program</li> <li>■ Sampling start</li> <li>■ End of sampling</li> <li>■ Dosing</li> <li>■ Sampling cycle</li> <li>■ Bottle change</li> <li>■ External stop</li> <li>■ No sample</li> </ul> <b>Factory setting</b> Sampling cycle	<b>Program enabled:</b> A permanent signal is switched when the sampling program starts. <b>End of program:</b> A pulse or permanent signal is switched when the sampling program ends. <b>Sampling start:</b> A pulse is switched when a sample is taken. <b>End of sampling:</b> A pulse is switched when sampling has ended. <b>Dosing:</b> A pulse is switched while the device doses a sample. <b>Sampling cycle:</b> The output signal is switched for the duration of the sampling cycle. <b>Bottle change:</b> A pulse is switched when a bottle is changed. <b>External stop:</b> A pulse is switched when an external stop is performed. <b>No sample:</b> The output signal is switched if no sample was taken.
If Function: <b>Limit value</b> is selected:		
Signal slope	Options <ul style="list-style-type: none"> <li>■ Low-High</li> <li>■ High-Low</li> </ul> <b>Factory setting</b> Low-High	Select the level change of the signal
Source of data	Options <ul style="list-style-type: none"> <li>■ None</li> <li>■ Limit switch 1-8</li> </ul> <b>Factory setting</b> None	Select the limit switch via which the status of the relay is to be output. The limit switches are configured in the "Setup/Additional functions/LimitSwitch" menu.
If Function: <b>Diagnostics message</b> is selected:		
Signal slope	Options <ul style="list-style-type: none"> <li>■ Low-High</li> <li>■ High-Low</li> </ul> <b>Factory setting</b> Low-High	Select the level change of the signal

## Path: Menu/Setup/Outputs

Function	Options	Info
Operating mode	Options <ul style="list-style-type: none"> <li>■ as assigned</li> <li>■ Namur M</li> <li>■ Namur S</li> <li>■ Namur C</li> <li>■ Namur F</li> </ul> <b>Factory setting</b> as assigned	<b>as assigned:</b> If this option is selected, the diagnostics messages which you have individually assigned to the binary output are output via the binary output.  <b>Namur M - F:</b> If you decided to use one of the Namur classes, all the messages that are assigned to the individual class are output via the binary output. You can also change the Namur class assignment for every diagnostics message. (Menu/Setup/General settings/Diagnostics/Device behavior or Menu/Setup/Inputs/././Diagnostics settings/Diag. behavior)
▷ Attributed diagnostic messages	Read only List of diagnostic messages	All the messages assigned to the relay output appear on the display. You do not have the option of editing the information here.
If Function: <b>Cleaning</b> is selected: (only for version with sensors with the Memosens protocol)		
Signal slope	Options <ul style="list-style-type: none"> <li>■ Low-High</li> <li>■ High-Low</li> </ul> <b>Factory setting</b> Low-High	Select the level change of the signal
Assignment	Options <ul style="list-style-type: none"> <li>■ None</li> <li>■ Cleaning 1-4</li> </ul> <b>Factory setting</b> None	Use this function to choose the cleaning instance which should be started when the binary output is active.

## 5.2 Current outputs (optional)

Two optional current outputs are available on Basic module L.  
Set the current range from 0 to 20 mA or 4 to 20 mA under Menu/Setup/General settings.

Possible applications

- For outputting a measured value to a process control system or an external recorder
- For outputting a manipulated variable to connected actuators

 The current output curve is always linear.

**Path: Menu/Setup/Outputs/Current output**

Function	Options	Info
Current output	Options <ul style="list-style-type: none"> <li>■ On</li> <li>■ Off</li> </ul> <b>Factory setting</b> Off	Use this function to activate and deactivate a variable being output at the current output
Source of data	Options <ul style="list-style-type: none"> <li>■ None</li> <li>■ Connected inputs</li> <li>■ Temperature sensors</li> </ul> <b>Factory setting</b> None	The sources of data on offer depend on your device version. All the sensors and controllers connected to inputs are available for selection.
Measured value	Options <ul style="list-style-type: none"> <li>■ None</li> <li>■ Depends on theSource of data</li> </ul> <b>Factory setting</b> None	The measured value you can select depends on the option selected under "Source of data".
<p> The table on the next page lists the measured values available depending on the data source. In the "Additional functions" menu, you can also select and configure the current output for outputting the controlled variable.</p>		
Range lower value	Selection range and factory settings depend on: "Measured value"	You can output the entire measuring range of the "Measured value" or just some of it at the current output. For this purpose, specify the start and end of the range in accordance with your requirements.
Range upper value		
Hold behavior	Options <ul style="list-style-type: none"> <li>■ Freeze</li> <li>■ Fixed value</li> <li>■ None</li> </ul> <b>Factory setting</b> Depends on the channel:output	<p><b>Freeze</b> The device freezes the last current value.</p> <p><b>Fixed value</b> You define a fixed current value that is output at the output.</p> <p><b>None</b> A hold does not affect this current output.</p>
Hold current <i>Hold behavior="Fixed value"</i>	0.0 to 23.0 mA <b>Factory setting</b> 22.0 mA	Specify which current should be output at this current output in the event of a hold.

## Measured value depending on the Source of data

Source of data	Measured value
pH Glass	Options
pH ISFET	<ul style="list-style-type: none"> <li>■ Raw value mV</li> <li>■ pH</li> <li>■ Temperature</li> </ul>
ORP	Options <ul style="list-style-type: none"> <li>■ Temperature</li> <li>■ ORP mV</li> <li>■ ORP %</li> </ul>
Oxygen (amp.)	Options
Oxygen (opt.)	<ul style="list-style-type: none"> <li>■ Temperature</li> <li>■ Partial pressure</li> <li>■ Concentration liquid</li> <li>■ Saturation</li> <li>■ Raw value nA (only Oxygen (amp.))</li> <li>■ Raw value <math>\mu</math>s (only Oxygen (opt.))</li> </ul>
Cond i	Options
Cond c	<ul style="list-style-type: none"> <li>■ Temperature</li> <li>■ Conductivity</li> <li>■ Resistance (only Cond c)</li> <li>■ Concentration (only Cond i)</li> </ul>
Chlorine	Options <ul style="list-style-type: none"> <li>■ Temperature</li> <li>■ Current</li> <li>■ Concentration</li> </ul>
ISE	Options <ul style="list-style-type: none"> <li>■ Temperature</li> <li>■ pH</li> <li>■ Ammonium</li> <li>■ Nitrate</li> <li>■ Potassium</li> <li>■ Chloride</li> </ul>
TU/TS	Options <ul style="list-style-type: none"> <li>■ Temperature</li> <li>■ Turbidity g/l</li> <li>■ Turbidity FNU</li> </ul>
Nitrate	Options <ul style="list-style-type: none"> <li>■ Temperature</li> <li>■ NO<sub>3</sub></li> <li>■ NO<sub>3</sub>-N</li> </ul>
UIS (interface measurement)	Options <ul style="list-style-type: none"> <li>■ Interface</li> <li>■ Turbidity</li> </ul>

**Measured value depending on the Source of data**

Source of data	Measured value
SAC	Options <ul style="list-style-type: none"> <li>■ Temperature</li> <li>■ SAC</li> <li>■ Transm.</li> <li>■ Absorption</li> <li>■ COD</li> <li>■ BOD</li> </ul>
Current input 1-3	Options depend on the configuration
Temperature 1-3	
Mathematical functions	All the mathematical functions can also be used as a data source and the calculated value can be used as the measured value.

### 5.3 Alarm relays

 The alarm relay is not available in devices with a battery backup system. The alarm relay is required to switch off the device completely when operating with the storage battery.

**The following functions can be output via a relay**

- Limit switch status
- Diagnostics messages
- Status of a cleaning function in order to control a pump or a valve

 You can assign a relay to multiple inputs in order to clean several sensors with just one cleaning unit, for example.

**Path: Menu/Setup/Outputs/Alarm relay or relay at channel no.**

Function	Options	Info
Function	Options <ul style="list-style-type: none"> <li>■ Off</li> <li>■ LimitSwitch</li> <li>■ Diagnostics</li> <li>■ Cleaning</li> </ul> <b>Factory setting</b> Off	The following functions depend on the option selected. These versions are illustrated individually in the following section to provide a clearer understanding of the options.  Function="Off" switches off the relay function and means no further settings are required.



### 5.3.1 Outputting the status of a limit switch

Function="LimitSwitch"

Function	Options	Info
Source of data	Options <ul style="list-style-type: none"> <li>■ None</li> <li>■ Limit switch 1</li> <li>■ Limit switch 2</li> <li>■ Limit switch 3</li> <li>■ Limit switch 4</li> <li>■ Limit switch 5</li> <li>■ Limit switch 6</li> <li>■ Limit switch 7</li> <li>■ Limit switch 8</li> </ul> <b>Factory setting</b> None	Select the limit switch via which the status of the relay is to be output. The limit switches are configured in the "Setup/Additional functions/Limit switches" menu.

### 5.3.2 Outputting diagnostics messages via the relay

You can output two categories of diagnostics messages via the relay:

1. Diagnostics messages from one of the 4 Namur classes  
(→ BA00463C "Maintenance&diagnostics" for more information on the Namur classes)
2. Diagnostics messages which you have individually assigned to the relay output

A message is individually assigned to the relay output at 2 specific points in the menu:

- Menu/Setup/General settings/Diagnostics/Device behavior  
(device-specific messages)
- Menu/Setup/Inputs/././Diagnostics settings/Diag. behavior  
(sensor-specific messages)



Before being able to assign a special message to the relay output in "Device behavior", you must first configure Outputs/relay x:y or /Alarm relay/Function="Diagnostics".

**Function="Diagnostics"**

Function	Options	Info
Operating mode	<p>Options</p> <ul style="list-style-type: none"> <li>■ as assigned</li> <li>■ Namur M</li> <li>■ Namur S</li> <li>■ Namur C</li> <li>■ Namur F</li> </ul> <p><b>Factory setting</b> as assigned</p>	<p><b>as assigned</b> If this option is selected, the diagnostics messages which you have individually assigned to the relay are output via the relay.</p> <p><b>Namur M... F</b> If you decided to use one of the Namur classes, all the messages that are assigned to the individual class are output via the relay. You can also change the Namur class assignment for every diagnostics message. (Menu/Setup/General settings/Diagnostics/Device behavior or Menu/Setup/Inputs/././Diagnostics settings/Diag. behavior)</p>
Attributed diagnostic messages <i>Operating mode="as assigned"</i>	<p>Read only List of diagnostic messages</p>	<p>All the messages assigned to the relay output appear on the display. You do not have the option of editing the information here.</p>

**5.3.3 Outputting the status of a cleaning function**

**Function="Cleaning"**

Function	Options	Info
Assignment	<p>Options</p> <ul style="list-style-type: none"> <li>■ None</li> <li>■ Cleaning 1 - Water</li> <li>■ Cleaning 1 - Cleaner</li> <li>■ Cleaning 2 - Water</li> <li>■ Cleaning 2 - Cleaner</li> <li>■ Cleaning 3 - Water</li> <li>■ Cleaning 3 - Cleaner</li> <li>■ Cleaning 4 - Water</li> <li>■ Cleaning 4 - Cleaner</li> </ul> <p><b>Factory setting</b> None</p>	<p>Here you can specify how a cleaning function should be displayed for the alarm relay.</p> <p>You can define the cleaning programs under: Menu/Setup/Additional functions/Cleaning.</p>

---

## 5.4 HART

Specify which device variables should be output via HART communication.

You can define a maximum of 16 variables:

- ▶ Define the data source. You can choose from the sensor inputs and the controllers.
  - ▶ From the source, select the measured value that should be output.
  - ▶ Define how the device should behave in the event of a "Hold".
  - ▶ The configuration options for "Source of data", "Measured value" and "Hold behavior" are identical to those described in the "Outputs/Current outputs" section. Please refer to this section for more information.
  - ▶ Please note that if you select Hold behavior="Freeze", the system not only flags the status but also actually "freezes" the measured value.
-  More information is provided in BA00486C "HART communication".

## 6 Additional functions

### 6.1 Limit switch

There are different ways of configuring a limit switch:

- Assigning a switch-on and switch-off point
- Assigning a switch-on and switch-off delay for a relay
- Setting an alarm threshold and also outputting an error message
- Starting a cleaning function

**Path: Menu/Setup/Additional functions/Limit switches/Limit switches 1 to 8**

Function	Options	Info
Source of data	Options <ul style="list-style-type: none"> <li>■ None</li> <li>■ Connected sensors</li> <li>■ Connected inputs</li> <li>■ Temperature sensors</li> </ul> <b>Factory setting</b> None	Specify the input or output which should be the source of data for the limit switch.  The sources of data on offer depend on your device version. All the sensors and controllers connected to inputs are available for selection.
Measured value	Options <ul style="list-style-type: none"> <li>■ None</li> <li>■ Depends on theSource of data</li> </ul> <b>Factory setting</b> None	The measured value you can select depends on the option selected under "Source of data".

#### Measured value depending on theSource of data

Source of data	Measured value
pH Glass	Options <ul style="list-style-type: none"> <li>■ Raw value mV</li> <li>■ pH</li> <li>■ Temperature</li> </ul>
pH ISFET	
ORP	Options <ul style="list-style-type: none"> <li>■ Temperature</li> <li>■ ORP mV</li> <li>■ ORP %</li> </ul>
Oxygen (amp.)	Options <ul style="list-style-type: none"> <li>■ Temperature</li> <li>■ Partial pressure</li> <li>■ Concentration liquid</li> <li>■ Saturation</li> <li>■ Raw value nA (only Oxygen (amp.))</li> <li>■ Raw value <math>\mu</math>s (only Oxygen (opt.))</li> </ul>
Oxygen (opt.)	

**Measured value depending on the Source of data**

Source of data	Measured value
Cond i	Options <ul style="list-style-type: none"> <li>■ Temperature</li> <li>■ Conductivity</li> <li>■ Resistance (only Cond c)</li> <li>■ Concentration (only Cond i)</li> </ul>
Cond c	
Chlorine	Options <ul style="list-style-type: none"> <li>■ Temperature</li> <li>■ Current</li> <li>■ Concentration</li> </ul>
ISE	Options <ul style="list-style-type: none"> <li>■ Temperature</li> <li>■ pH</li> <li>■ Ammonium</li> <li>■ Nitrate</li> <li>■ Potassium</li> <li>■ Chloride</li> </ul>
TU/TS	Options <ul style="list-style-type: none"> <li>■ Temperature</li> <li>■ Turbidity g/l</li> <li>■ Turbidity FNU</li> </ul>
Nitrate	Options <ul style="list-style-type: none"> <li>■ Temperature</li> <li>■ NO3</li> <li>■ NO3-N</li> </ul>
UIS (interface measurement)	Options <ul style="list-style-type: none"> <li>■ Interface</li> <li>■ Turbidity</li> </ul>
SAC	Options <ul style="list-style-type: none"> <li>■ Temperature</li> <li>■ SAC</li> <li>■ Transm.</li> <li>■ Absorption</li> <li>■ COD</li> <li>■ BOD</li> </ul>
Current input 1-3	Options depend on the configuration
Temperature 1-3	
Mathematical functions	All the mathematical functions can also be used as a data source and the calculated value can be used as the measured value.

**Path: Menu/Setup/Additional functions/Limit switches/Limit switches 1 to 8**

Function	Options	Info
Cleaning program	Options <ul style="list-style-type: none"> <li>■ None</li> <li>■ Cleaning 1</li> <li>■ Cleaning 2</li> <li>■ Cleaning 3</li> <li>■ Cleaning 4</li> </ul> <b>Factory setting</b> None	Use this function to choose the cleaning instance which should be started when the limit switch is active.
Function	Options <ul style="list-style-type: none"> <li>■ On</li> <li>■ Off</li> </ul> <b>Factory setting</b> Off	Activating/deactivating the limit switch
Operating mode	Options <ul style="list-style-type: none"> <li>■ Above limit check</li> <li>■ Below limit check</li> <li>■ In range check</li> <li>■ Out of range check</li> <li>■ Change rate</li> </ul> <b>Factory setting</b> Above limit check	Type of limit value monitoring: <ul style="list-style-type: none"> <li>■ Limit value overshoot or undershoot</li> <li>■ Measured value within or outside a range</li> <li>■ Rate of change</li> </ul>
Limit value	<b>Range of adjustment and factory setting</b> Depends on the measured value	<i>Operating mode="Above limit check" or "Below limit check"</i>
<ul style="list-style-type: none"> <li>■ If the measured values are increasing, the relay contact is closed when the on-value is exceeded ("Limit value" + ½ "Hysteresis") and the start delay has elapsed ("Start delay").</li> <li>■ If the measured values are decreasing, the relay contact is reset when the off-value is undershot ("Limit value" - ½ "Hysteresis") and following the release delay ("Switch off delay").</li> </ul>		
Range lower value	<b>Range of adjustment and factory setting</b> Depends on the measured value	<i>Operating mode="In range check" or "Out of range check"</i>
Range upper value		
<ul style="list-style-type: none"> <li>■ If the measured values are increasing, the relay contact is closed when the on-value is exceeded ("Range lower value" + ½ "Hysteresis") and the start delay has elapsed ("Start delay").</li> <li>■ If the measured values are decreasing, the relay contact is reset when the off-value is undershot ("Range upper value" - ½ "Hysteresis") and following the release delay ("Switch off delay").</li> </ul>		
Hysteresis	<b>Range of adjustment and factory setting</b> Depends on the measured value	The hysteresis is the difference between the switch-on point and the switch-off point if values, which cause the limit switch to pick up, become closer or move further apart. It is needed to ensure a stable switching behavior.
Start delay	0 to 9999 s	Synonyms: pick-up and drop-out delay
Switch off delay	<b>Factory setting</b> 0 s	

Path: Menu/Setup/Additional functions/Limit switches/Limit switches 1 to 8

Function	Options	Info
Delta value	<b>Range of adjustment and factory setting</b> Depends on the measured value	<i>Operating mode="Change rate"</i>
Delta time	00:01 to 23:59 <b>Factory setting</b> 01:00	
Auto Confirm	00:01 to 23:59 <b>Factory setting</b> 00:01	

## 6.2 Cleaning programs (only for version with sensors with the Memosens protocol)

Path: Menu/Setup/Additional functions/Cleaning/Cleaning 1 to 4

Function	Options	Info
Cleaning type	Options <ul style="list-style-type: none"> <li>■ Standard clean</li> <li>■ Chemoclean</li> </ul> <b>Factory setting</b> Standard clean	
Cleaning time	5 to 600 s <b>Factory setting</b> 10 s	Cleaning time... Cleaning duration The cleaning duration and interval depend on the process and sensor. Determine the variables empirically or based on experience.
Cleaning interval	00-00:01 to 07-00:00 (DD-hh:mm) <b>Factory setting</b> 01-00:00	The interval value can be between 1 minute and 7 days. Example: You have set the value "01-00:00". Each day, the cleaning cycle starts at the same time you started the first cleaning cycle.

**Path: Menu/Setup/Additional functions/Cleaning/Cleaning 1 to 4**

Function	Options	Info
Hold behavior	Options <ul style="list-style-type: none"> <li>■ On</li> <li>■ Off</li> </ul> <b>Factory setting</b> Off	Decide whether there should be a hold for the assigned sensor during the cleaning process.
▶ Output selection		Goes to the "Outputs" menu You can assign the cleaning program directly to one or more outputs. → "Outputs" section
▷ Start cycle	Action	Start the cyclical cleaning process with the settings above
▷ Start manually	Action	Start an individual cleaning process If cyclical cleaning is enabled, there are times in which it is not possible to manually start the process.
▷ Stop	Action	End the cleaning process (cyclically or manually)
State of cleaning	Read only	Indicates whether cleaning is currently taking place or not
Time to next clean	Read only	Countdown to the next cleaning process (only if cyclical cleaning has been started)

### 6.3 Mathematical functions

In addition to "real" process values which are delivered by analog inputs or physical sensors connected to the device, you can also calculate a maximum of 6 "virtual" process values using mathematical functions.

The "virtual" process values can be:

- Output via a current output or a fieldbus
- Used as a controlled variable
- Assigned as a measured variable to a limit contactor
- Used as a measured variable to trigger cleaning
- Displayed in user-defined measuring menus.



### 6.3.1 Difference

You can subtract the measured values of two sensors and use the result to detect incorrect measurements, for example.

To calculate a difference, you must use two measured values with the same engineering unit.

**Path: Menu/Setup/Additional functions/Mathematical functions/MF 1 to 6/Mode/Difference**

Function	Options	Info
Calculation	Options <ul style="list-style-type: none"> <li>■ Off</li> <li>■ On</li> </ul> <b>Factory setting</b> Off	On/off switch for the function
Y1	The options depend on the sensors connected	Select the sensors and the measured variables that should be used as the minuend (Y1) or subtrahend (Y2).
Measured value		
Y2		
Measured value		
Difference value	Read only	View this value in a user-defined measuring screen or output the value via the current output.

### 6.3.2 Redundancy

Use this function to monitor two or three sensors with redundant measurements. The arithmetic average of the two closest measured values is calculated and output as the redundancy value.

**Path: Menu/Setup/Additional functions/Mathematical functions/MF 1 to 6/Mode/Redundancy**

Function	Options	Info
Calculation	Options <ul style="list-style-type: none"> <li>■ Off</li> <li>■ On</li> </ul> <b>Factory setting</b> Off	On/off switch for the function
Y1	The options depend on the sensors connected	You can select different types of sensor that output the same measured value.  <b>Example for temperature redundancy:</b> You have a pH sensor and an oxygen sensor at inputs 1 and 2. Select both as "Y1" and "Y2". For "Measured value" select the temperature.
Measured value		
Y2		
Measured value		
Y3 (optional)		
Measured value		

**Path: Menu/Setup/Additional functions/Mathematical functions/MF 1 to 6/Mode/Redundancy**

Function	Options	Info
Deviation control	Options <ul style="list-style-type: none"> <li>■ Off</li> <li>■ On</li> </ul> <b>Factory setting</b> Off	You can monitor the redundancy. Specify an absolute limit value that may not be exceeded.
Deviation limit	Depends on the selected measured value	
Redundancy	Read only	View this value in a user-defined measuring screen or output the value via the current output.

**6.3.3 rH value**

To calculate the rH value, a pH sensor and an ORP sensor must be connected. It is irrelevant whether you are using a pH glass sensor, an ISFET sensor or the pH electrode of an ISE sensor.

**Path: Menu/Setup/Additional functions/Mathematical functions/MF 1 to 6/Mode/rH calculation**

Function	Options	Info
Calculation	Options <ul style="list-style-type: none"> <li>■ Off</li> <li>■ On</li> </ul> <b>Factory setting</b> Off	On/off switch for the function
pH source	Connected pH sensor	Set the input for the pH sensor and the input for the ORP sensor. Measured value interrogation is obsolete as you must select pH or ORP mV.
ORP source	Connected ORP sensor	
Calculated rH	Read only	View this value in a user-defined measuring screen or output the value via the current output.

**6.3.4 Degassed conductivity**

Carbon dioxide from the air can be a contributing factor to the conductivity of a medium. The degassed conductivity is the conductivity of the medium excluding the conductivity caused by carbon dioxide.

In the power station industry, for example, it is advantageous to use the degassed conductivity:

- The percentage of conductivity caused by corrosion products or fouling in the feed water can be determined as early as when the turbines are started. The system excludes the initially high conductivity values resulting from the ingress of air.
- If carbon dioxide is regarded as non-corrosive, the live steam can be directed to the turbine far earlier during startup.
- If the conductivity value increases during normal operation, it is possible to immediately determine an ingress of coolant or air by calculating the degassed conductivity.

**Path: Menu/Setup/Additional functions/Mathematical functions/MF 1 to 6/Mode/Degassed conductivity**

Function	Options	Info
Calculation	Options <ul style="list-style-type: none"> <li>■ Off</li> <li>■ On</li> </ul> <b>Factory setting</b> Off	On/off switch for the function
Cation conductivity	Connected conductivity sensor	"Cation conductivity" is the sensor downstream from the cation exchanger and upstream from the "degassing module", "Degassed conductivity" is the sensor at the outlet of the degassing module. Measured value interrogation is obsolete as you can only choose conductivity.
Degassed conductivity	Connected conductivity sensor	
CO2 concentration	Read only	View this value in a user-defined measuring screen or output the value via the current output.

**6.3.5 Dual conductivity**

You can subtract two conductivity values and use the result, for example, to monitor the efficiency of an ion exchanger.

**Path: Menu/Setup/Additional functions/Mathematical functions/MF 1 to 6/Mode/Dual conductivity**

Function	Options	Info
Calculation	Options <ul style="list-style-type: none"> <li>■ Off</li> <li>■ On</li> </ul> <b>Factory setting</b> Off	On/off switch for the function
Inlet	The options depend on the sensors connected	Select the sensors that should be used as the minuend (Inlet, e.g. sensor upstream from the ion exchanger) and subtrahend (Outlet, e.g. sensor downstream from the ion exchanger).
Measured value		
Outlet		
Measured value		
Main value format	Options <ul style="list-style-type: none"> <li>■ Auto</li> <li>■ #</li> <li>■ #.#</li> <li>■ #.##</li> <li>■ #.###</li> </ul> <b>Factory setting</b> Auto	

**Path: Menu/Setup/Additional functions/Mathematical functions/MF 1 to 6/Mode/Dual conductivity**

Function	Options	Info
Cond. unit	Options <ul style="list-style-type: none"> <li>■ Auto</li> <li>■ <math>\mu\text{S}/\text{cm}</math></li> <li>■ <math>\text{mS}/\text{cm}</math></li> <li>■ <math>\text{S}/\text{cm}</math></li> <li>■ <math>\mu\text{S}/\text{m}</math></li> <li>■ <math>\text{mS}/\text{m}</math></li> <li>■ <math>\text{S}/\text{m}</math></li> </ul> <b>Factory setting</b> Auto	
Dual conductivity	Read only	View this value in a user-defined measuring screen or output the value via the current output.

**6.3.6 Calculated pH value**

The pH value can be calculated from the measured values of two conductivity sensors under certain conditions. Areas of application include power stations, steam generators and boiler feedwater.

**Path: Menu/Setup/Additional functions/Mathematical functions/MF 1 to 6/Mode/pH calculation from conductivity**

Function	Options	Info
Calculation	Options <ul style="list-style-type: none"> <li>■ Off</li> <li>■ On</li> </ul> <b>Factory setting</b> Off	On/off switch for the function
Method	Options <ul style="list-style-type: none"> <li>■ NaOH</li> <li>■ NH3</li> </ul> <b>Factory setting</b> NaOH	The calculation is performed on the basis of Guideline VGB-R-450L of the Technical Association of Large Power Plant Operators (Verband der Großkesselbetreiber, (VGB)).  <b>NaOH</b> $\text{pH} = 8.60 + \log(\kappa_{\text{direct}} - 1/3 \kappa_{\text{acid}})$ <b>NH3</b> $\text{pH} = 8.56 + \log(\kappa_{\text{direct}} - 1/3 \kappa_{\text{acid}})$  $\kappa_{\text{direct}} \dots$ "Inlet" $\kappa_{\text{acid}} \dots$ "Outlet"
Inlet	Choice of conductivity sensor	Inlet
Outlet		Sensor upstream from the cation exchanger, "direct conductivity" Outlet Sensor downstream from the cation exchanger, "acid conductivity" The choice of measured value is obsolete since it must always be "Conductivity".
Calculated pH	Read only	View this value in a user-defined measuring screen or output the value via the current output.

## 7 Communication

### 7.1 Web server

#### 7.1.1 Connection

- ▶ Connect the PC communication cable to the RJ45 port of module 485.

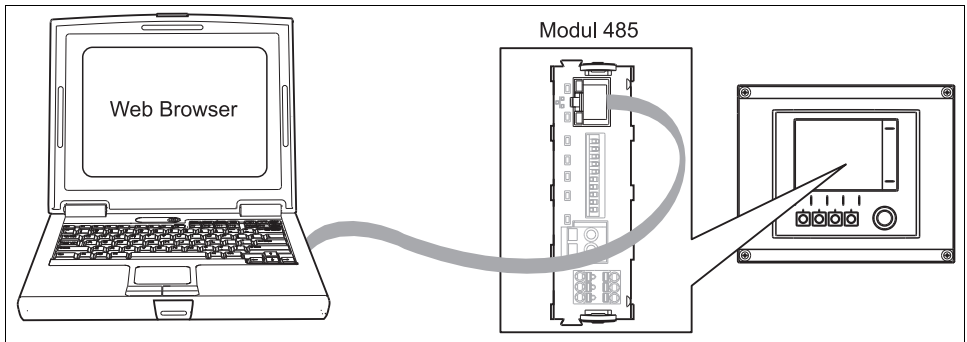

Fig. 9: Ethernet connection

40016226

#### 7.1.2 Creating the data connection

1. Start your PC.
2. First, set a manual IP address in the network connection settings of the operating system. This address must be in the same subnetwork as the IP address of the device.
 

**Example:**

  - IP address Liquiline: 192.168.1.212 (Diagnostics/System information/Ethernet/IP-Address)
  - IP address for the PC: 192.168.1.**213**
3. Start the Internet browser.
4. If you use a proxy server to connect to the Internet: Disable the proxy (browser settings under "Connections/LAN settings").
5. Enter the IP address of your device in the address line.
 

→ The system takes a few moments to establish the connection and then the CM44 web server starts.
6. Enter the following address(es) to download logbooks:
  - 192.168.1.212/logbooks\_csv.fhtml (for logbooks in CSV format)
  - 192.168.1.212/logbooks\_fdm.fhtml (for logbooks in FDM format)

### 7.1.3 Operation

The menu structure of the web server corresponds to the onsite operation.

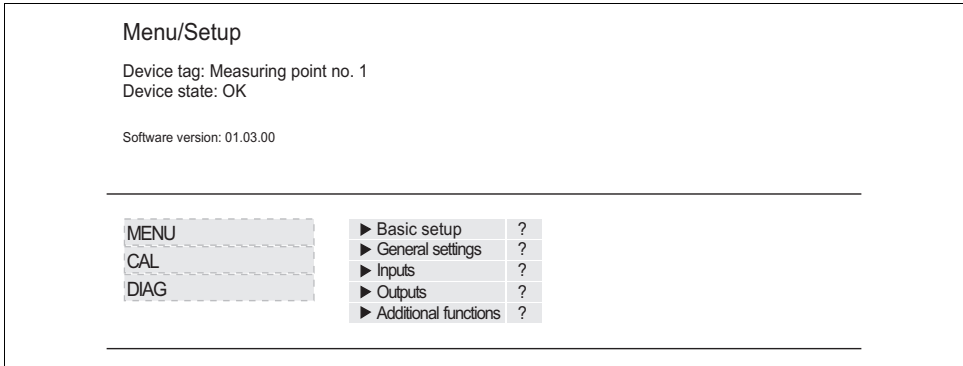



Fig. 10: Example of web server (menu/language=English)

a0016397

- Clicking a menu name or a function corresponds to pressing the navigator.
- You can make your settings conveniently via the computer keyboard.

 Instead of using an Internet browser, you can also use FieldCare for configuration via ethernet. The ethernet DTM required for this purpose can be downloaded from the product page.

## 7.2 Service interface

You can connect the device to a computer via the service interface and configure it using "FieldCare". Furthermore, configurations can also be saved, transferred and documented.

### 7.2.1 Connection

- ▶ Connect the service port on the controller housing to the Commubox (FXA291).
- ▶ Via the USB port, connect the Commubox to the computer.
- ▶ Commubox is supplied with a CD which contains USB drivers that must be installed when connecting for the first time.
- ▶ FieldCare must be installed on the computer for the application. The software can either be downloaded from [www.de.endress.com](http://www.de.endress.com) or ordered on a CD.

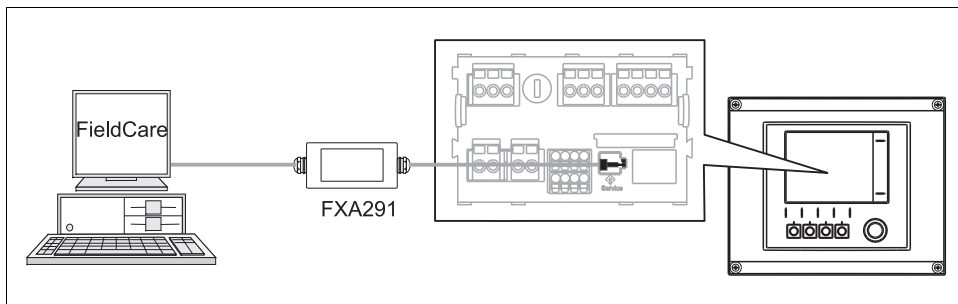

Fig. 11: Connection overview

40015904

### 7.2.2 Creating the data connection

- ▶ Start Fieldcare.
- ▶ Establish the connection to the Commubox.
- ▶ For this purpose, under "Host PC" click "Add device" and select "CDI Communication FXA291".
- ▶ Click "Configuration" to select the serial interface for FXA291 and to set the baud rate (115200).
- ▶ Click "Link connection" to start communicating with the FXA291 (<|> are green).
- ▶ Click "Add device" again and select your device type.
- ▶ Click "Link connection" to start communicating with the device (<|> are green).
- ▶ Select "Online parameterize" to be able to communicate with the device online.

You can now start online configuration via the DTM.

Online configuration competes with onsite operation, i.e. each of the two options blocks the other one. Either side is able to prevent access from the other side.

### 7.2.3 Operation

- In the DTM the menu structure corresponds to the onsite operation. The functions of the Liquiline softkeys are located on the left in the main window. Here is where you also navigate through the software.
- Clicking a menu name or a function corresponds to pressing the navigator.
- You can make your settings conveniently via the computer keyboard.
- Via Fieldcare, you can save logbooks, make backups of configurations and transfer the configurations to other devices.
- To start exporting the logbook click "Operating devices", "Device functions" and "Further functions". Select ".dat" to save the file in a protected format for processing with the Field Data Manager.
- You can also print out configurations or save them as PDFs.

## 7.3 Fieldbuses

### 7.3.1 HART

You can communicate via current output 1 using the HART protocol.

- ▶ Connect the HART modem or handheld to current output 1 (communication load 230 - 500 Ohm).
- ▶ Establish the connection via your HART device.
- ▶ Operate Liquiline via the HART device. To do so, follow the instructions in the manual.

 All the information on HART communication with Liquiline is provided on the CD (→ BA00486C).

### 7.3.2 PROFIBUS DP

With the fieldbus module 485 and the appropriate device version, you can communicate via PROFIBUS DP.

Connect the PROFIBUS data cable to the terminals of the fieldbus module as described (→ BA00443C "Commissioning").

### 7.3.3 Modbus

With the fieldbus module 485 and the appropriate device version, you can communicate via Modbus RS485 or Modbus TCP.

Connect the Modbus data cable to the terminals of the fieldbus module (RS 485) or to the RJ45 (TCP) port as described (→ BA00443C "Commissioning").



## 8 Information on sensors with the Memosens protocol

The following options are only available for versions with at least one digital sensor with Memosens technology.

Sensors with the Memosens protocol have integrated electronics that save calibration data and other information. The sensor data are automatically communicated to the transmitter when the sensor is connected and are used to calculate the measured value.

Data digital sensors save include:

- Manufacturer data
  - Serial number
  - Order code
  - Date of manufacture
- Calibration data
  - Date of calibration
  - Calibration values
  - Number of calibrations
  - Serial number of the transmitter used to perform the last calibration
- Operating data
  - Date of initial commissioning
  - Hours of operation under extreme operating conditions
  - Sensor monitoring data

 The specific data that are recorded and communicated to the transmitter depend on the sensor used. Differences can also occur within a sensor type. This causes different menu items to be displayed or hidden depending on the sensor connected. Pay attention to specific information in this manual.

### Example:

The amperometric oxygen sensor COS51D cannot be sterilized. For this reason, you will not be able to define limit values for sterilization in the diagnostics settings for this sensor. On the other hand, these menu items are displayed for a sterilizable amperometric sensor, such as COS22D.

## 9 Inputs: General

### 9.1 Configuration

An input can be configured in one of two ways:

1. Configuration where a sensor is not connected
  - ▶ Select the appropriate channel.
  - ▶ From the list of sensor types, select the sensor which you want to configure.
  - ▶ Configure the channel as explained in the following sections.
  - ▶ Connect the selected sensor type later on.
2. Configuration where a sensor is connected
  - ▶ Configure the channel as explained in the following sections.

The following applies when configuring without a sensor:

- Some settings require sensor communication.  
You cannot make these settings if a sensor is not connected.
- It is also possible to save a setup and transfer it to another device (see "Data management" in the "General settings" section). This function might be a better option than performing a configuration when a sensor is not connected.

### 9.2 Frequently occurring functions

Some submenus are identical for all sensor types.

These submenus are explained below so you can find a description of these menus in one central location. Instead of repeating the description, the sensor-specific section then only contains a reference to this chapter.

#### 9.2.1 Damping

The damping causes a floating average curve of the measured values over the time specified.

**Path:** Menu/Setup/Inputs/<Sensor type>

Function	Options	Info
Damping <Sensor type>	0 to 600 s	You specify the damping of the main measured value of the connected sensor and that of the integrated temperature sensor.
Damping temp.	<b>Factory setting</b> 0 s	

## 9.2.2 Manual hold

Path: Menu/Setup/Inputs/<Sensor type>

Function	Options	Info
Manual hold	Options <ul style="list-style-type: none"> <li>■ On</li> <li>■ Off</li> </ul> <b>Factory setting</b> Off	<b>On</b> You can use this function to set the channel manually to "Hold". <b>Off</b> No hold

## 9.2.3 Cleaning

Path: Menu/Setup/Inputs/<Sensor type>/Extended setup

Function	Options	Info
Cleaning	Options <ul style="list-style-type: none"> <li>■ None</li> <li>■ Cleaning 1</li> <li>■ Cleaning 2</li> <li>■ Cleaning 3</li> <li>■ Cleaning 4</li> </ul> <b>Factory setting</b> None	Select a cleaning program.  This program is executed if: <ul style="list-style-type: none"> <li>■ A diagnostics message is present at the channel <b>and</b></li> <li>■ A cleaning process has been specified for this message (→ "Inputs/Diagnostics settings/Diag. behavior").</li> </ul>

 You define the cleaning programs in the "Setup/Additional functions/Cleaning" menu.

## 9.2.4 Calibration timer and calibration expiration date

You can specify the calibration interval for the sensor here.

Once the time configured elapses, the "Calibration timer" diagnostics message appears on the display.

 The timer is reset automatically if you recalibrate the sensor.

Path: Menu/Setup/Inputs/<Sensor type>/Extended setup/Calib. settings

Function	Options	Info
Calibration timer	Options <ul style="list-style-type: none"> <li>■ Off</li> <li>■ On</li> </ul> <b>Factory setting</b> Off	Switches the function on or off
Calibration timer value <i>Calibration timer="On"</i>	14 to 365 d (chlorine sensor) 1 to 10000 h (all others) <b>Factory setting</b> 180 d (chlorine sensor) 1000 h (all others)	Specify the time after which the timer should have timed out. Once this time has elapsed, the "Calib. Timer" diagnostics message, along with the code 102, appears on the display.

**Path: Menu/Setup/Inputs/<Sensor type>/Extended setup/Calib. settings**

Function	Options	Info
Calib. expiration date	Options <ul style="list-style-type: none"> <li>■ Off</li> <li>■ On</li> </ul> <b>Factory setting</b> Off	The function checks whether the calibration of a sensor is still valid. Example: You install a precalibrated sensor. The function checks how much time has elapsed since the sensor was last calibrated. A diagnostics message is displayed if the time since the last calibration is longer than the predefined warning and alarm limit.
▶ Calib. expiration date		
Warning limit	<b>Factory setting</b> 11 months	Diagnostics message: 105 "Calib. validity"
Alarm limit	<b>Factory setting</b> 12 months	Diagnostics message: 104 "Calib. validity"

Warning and alarm limits mutually affect each other's possible ranges for adjustment.  
 Range of adjustment which must include both limits: 1 to 24 months  
 Generally the following applies: alarm limit > warning limit

**9.2.5 Process check system (PCS)**

The process check system (PCS) checks the measuring signal for stagnation. An alarm is triggered if the measuring signal does not change over a certain period (several measured values).

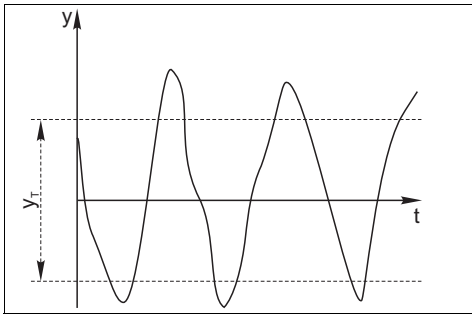

Fig. 12: Normal measuring signal, no alarm

$y$  Measuring signal  
 $y_T$  Set value for "Tolerance width"

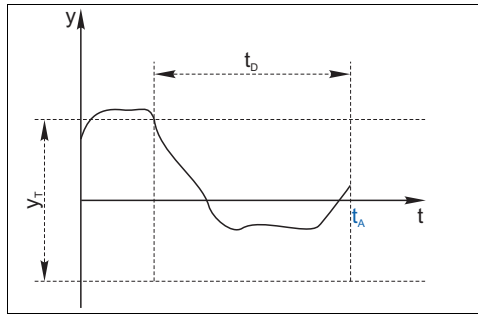

Fig. 13: Stagnating signal, alarm is triggered

$t_D$  Set value for "Duration"  
 $t_A$  Time when the alarm is triggered

The main causes of stagnating measured values are:

- Sensor fouled or outside the medium
- Sensor failure
- Process error (e.g. through control system)

Remedial action

- ▶ Clean the sensor.

- ▶ Check the position of the sensor in the medium.
- ▶ Check the electrode system.
- ▶ Switch off the controller and switch it back on again.

**Path: Menu/Setup/Inputs/<Sensor type>/Extended setup/Diagnostics settings**

Function	Options	Info
▶ Process Check System		Diagnostics code and associated message text: 904 "Process check"
Function	Options <ul style="list-style-type: none"> <li>■ On</li> <li>■ Off</li> </ul> <b>Factory setting</b> Off	
Duration	1 to 240 min <b>Factory setting</b> 60 min	The measured value must change during this time. Otherwise the error message is triggered.
Tolerance width <i>Not available for pH/ORP</i>	The range depends on the sensor <b>Factory setting</b> Depends on the sensor	Interval around the measuring signal (raw value) for detecting stagnation. Measured values within the set interval are regarded as stagnating.

## 9.2.6 Diagnostic behavior

The list of diagnostic messages displayed depends on the path selected. There are device-specific messages, and messages that depend on what sensor is connected.

**Path: ... /Extended setup/Diagnostics settings/Diag. behavior (optional)**

Function	Options	Info
List of diagnostic messages		Select the message to be changed. Only then can you make the settings for this message.
Diag. code	Read only	
Diagnostic message	Options <ul style="list-style-type: none"> <li>■ On</li> <li>■ Off</li> </ul> <b>Factory setting</b> Depends on the message	You can deactivate or reactivate a diagnostic message here. Deactivating means: <ul style="list-style-type: none"> <li>■ No error message in the measuring mode</li> <li>■ No error current at the current output</li> </ul>
Error current	Options <ul style="list-style-type: none"> <li>■ On</li> <li>■ Off</li> </ul> <b>Factory setting</b> Depends on the message	Decide whether an error current should be output at the current output if the diagnostic message display is activated. <p> If general device errors occur, the error current is output at all the current outputs. In the case of channel-specific errors, the error current is only output at the specific current output.</p>

**Path: ... /Extended setup/Diagnostics settings/Diag. behavior (optional)**

Function	Options	Info
Status signal	Options <ul style="list-style-type: none"> <li>■ Maintenance (M)</li> <li>■ Out of specification (S)</li> <li>■ Function check (C)</li> <li>■ Failure (F)</li> </ul> <b>Factory setting</b> Depends on the message	The messages are divided into different error categories in accordance with NAMUR NE 107. → BA00463C "Maintenance & diagnostics"
Diag. output	Options <ul style="list-style-type: none"> <li>■ None</li> <li>■ Alarm relay</li> <li>■ Relay 1 to n (depends on the device version)</li> </ul> <b>Factory setting</b> None	You can use this function to select a relay output and/or binary output to which the diagnostic message should be assigned.  For sensors with the Memosens protocol: You first have to configure a relay output before being able to assign the message to an output (Menu/Setup/Outputs, assign "Diagnostics" function and set Operating mode to "as assigned").
Cleaning program(optional)	Options <ul style="list-style-type: none"> <li>■ None</li> <li>■ Cleaning 1</li> <li>■ Cleaning 2</li> <li>■ Cleaning 3</li> <li>■ Cleaning 4</li> </ul> <b>Factory setting</b> None	Decide whether the diagnostic message should trigger a cleaning program. You can define the cleaning programs under: Menu/Setup/Additional functions/Cleaning.
Detail information	Read only	Here you can find more information on the diagnostic message and instructions on how to resolve the problem.

**9.2.7 Sterilizations**

The system counts the number of operating hours in which the sensor is exposed to a temperature that is typical for a sterilization. This temperature depends on the sensor.

**Path: Menu/Setup/Inputs/<Sensor type>/Extended setup/Diagnostics settings**

Function	Options	Info
► Sterilizations	0 to 99	Specify the limit values for the number of sensor sterilizations.
Function	Options <ul style="list-style-type: none"> <li>■ On</li> <li>■ Off</li> </ul> <b>Factory setting</b> Off	
Warning limit	<b>Factory setting</b> 30 <sup>1)</sup>	Diagnostics code and associated message text: 108 "Sterilization"

1) For oxygen: 25

## 9.2.8 Tag control

With this function, you specify which sensors are accepted at your device.



"Tag" stands for the name of a measuring point, and is used in many areas of process measuring technology.

Path: Menu/Setup/Inputs/<Sensor type>/Extended setup

Function	Options	Info
▶ Tag control		Additional information on the display: tag control currently used
Operating mode	Options <ul style="list-style-type: none"> <li>■ Off</li> <li>■ Tag</li> <li>■ Group</li> </ul> <b>Factory setting</b> Off	<b>Off</b> No tag control, all sensors are accepted. <b>Tag</b> Only sensors with the same tag are accepted. <b>Group</b> Only sensors in the same tag group are accepted.
Tag	Customized text <b>Factory setting</b> EH_CSF48_	Enter the tag name. The controller checks every sensor to be connected as to whether this sensor belongs to the measuring point, and only accepts the sensors that have the same tag.
Group	Numerical <b>Factory setting</b> 0	

## 9.2.9 Sensor replacement

When the sensor is replaced, the last measured value is retained via the "hold" function. A diagnostics message is not triggered.

### 9.2.10 Data processing factory setting

Here you can restore the factory settings for the sensor input. For this purpose, simply press the navigator button to select "OK" when the prompt for the device software appears. Only the factory settings for this particular input are restored. All other settings remain unchanged.

### 9.2.11 Sensor factory setting

Here you can restore the sensor factory settings. For this purpose, simply press the navigator button to select "OK" when the prompt for the device software appears. Only the factory settings for the sensor are restored. The settings for the input remain unchanged.

# 10 Inputs: pH/ORP

## 10.1 Basic settings

### 10.1.1 Sensor identification

Path: Menu/Setup/Inputs/<Sensor type>

Function	Options	Info
Channel	Options <ul style="list-style-type: none"> <li>■ On</li> <li>■ Off</li> </ul> <b>Factory setting</b> On	<b>On</b> The channel display is switched on in the measuring mode <b>Off</b> The channel is not displayed in the measuring mode, regardless of whether a sensor is connected or not.
Sensor type	Read only (Only available if a sensor is connected)	Connected sensor type
Order code		Order code of the connected sensor

### 10.1.2 Main value

Path: Menu/Setup/Inputs/pH or ORP

Function	Options	Info
Main value	Options <ul style="list-style-type: none"> <li>■ pH (only pH sensor)</li> <li>■ mV</li> <li>■ % (only ORP sensor)</li> </ul> <b>Factory setting</b> pH (pH sensor) mV (ORP sensor)	Select how the main measured value should be displayed. You can display the main measured value of a pH sensor as a pH value or as a raw value in mV. If using an ORP sensor, here you decide which ORP mode to use: mV or %. Subsequent configuration options depend on the option selected here.

### 10.1.3 Damping

→ "Inputs: General/Frequently occurring functions" section → 98

### 10.1.4 Manual hold



→ "Inputs: General/Frequently occurring functions" section → 98



## 10.2 Extended setup

### 10.2.1 Temperature and medium compensation (only pH)

Path: Menu/Setup/Inputs/pH/Extended setup

Function	Options	Info
Temp. compensation	Options <ul style="list-style-type: none"> <li>■ Off</li> <li>■ Automatic</li> <li>■ Manual</li> </ul> <b>Factory setting</b> Automatic	Decide how you want to compensate the medium temperature: <ul style="list-style-type: none"> <li>■ Automatically using the temperature sensor of your sensor (ATC)</li> <li>■ Manually by entering the medium temperature</li> <li>■ Not at all.</li> </ul>
 This setting only refers to compensation during measurement. You enter the compensation for calibration in the calibration settings.		
Medium comp.	Options <ul style="list-style-type: none"> <li>■ Off</li> <li>■ 2-point</li> <li>■ Table</li> </ul> <b>Factory setting</b> Off	Take a sample from the medium and determine its pH value at different temperatures in the lab. Decide whether you want to compensate using two points or several points in a table.
 The dissociation of water changes with increasing temperature. The balance shifts towards the protons; the pH value drops. You can balance out this effect with the "Medium compensation" function.		
Internal buffer <i>(only pH glass)</i>	pH 0 to 14 <b>Factory setting</b> pH 7.00	Only change the value if you are using a sensor with an internal buffer other than pH 7.

### 10.2.2 Measured value formats

Path: Menu/Setup/Inputs/pH or ORP/Extended setup

Function	Options	Info
Main value format <i>(only pH)</i>	Options <ul style="list-style-type: none"> <li>■ #.#</li> <li>■ #.##</li> </ul> <b>Factory setting</b> #.#	Specify the number of decimal places for displaying the main measured value.
Temperature format	Options <ul style="list-style-type: none"> <li>■ #.#</li> <li>■ #.##</li> </ul> <b>Factory setting</b> #.#	Select how many decimal places should be used to display the temperature.

### 10.2.3 Cleaning

→ "Inputs: General/Frequently occurring functions" section →  98

## 10.2.4 Calibration settings

### Stability criteria

You define the permitted measured value fluctuation which must not be exceeded in a certain timeframe during calibration.

If the permitted difference is exceeded, calibration is not permitted and is aborted automatically.

**Path:** Menu/Setup/Inputs/<Sensor type>/Extended setup/Calib. settings

Function	Options	Info
▶ Stability criteria		
Delta mV	1 to 10 mV <b>Factory setting</b> 1 mV	Permitted measured value fluctuation during calibration
Duration	10 to 60 s <b>Factory setting</b> 20 s	Timeframe within which the permitted range for measured value fluctuation should not be exceeded

### Buffer recognition (only pH)

#### *Automatic buffer recognition*

To ensure a buffer is detected correctly, the measuring signal may deviate by a maximum of 30 mV from the value stored in the buffer table. This is approx. 0.5 pH at a temperature of 25°C. If both buffers - 9.00 and 9.20 - were used, this would cause the signal intervals to overlap and buffer recognition would not work. For this reason, the device would recognize a buffer with a pH of 9.00 as a pH of 9.20. → Do not use the buffer with a pH of 9.00 for automatic buffer recognition.

**Path:** Menu/Setup/Inputs/pH/Extended setup/Calib. settings

Function	Options	Info
Temp. compensation	Options <ul style="list-style-type: none"> <li>■ Off</li> <li>■ Automatic</li> <li>■ Manual</li> </ul> <b>Factory setting</b> Automatic	Decide how you want to compensate the buffer temperature: <ul style="list-style-type: none"> <li>■ Automatically using the temperature sensor of your sensor (ATC)</li> <li>■ Manually by entering the buffer temperature</li> <li>■ Not at all.</li> </ul>
Temperature <i>Temp. compensation="Manual"</i>	-50 to 250 °C (-58 to 482 °F) <b>Factory setting</b> 25 °C (77 °F)	Specify the buffer temperature.
 This setting only refers to compensation during calibration, not in measuring mode. You perform the compensation in the measuring mode further down in the menu.		

**Path: Menu/Setup/Inputs/pH/Extended setup/Calib. settings**

Function	Options	Info
Buffer recognition	Options <ul style="list-style-type: none"> <li>■ Fixed</li> <li>■ Automatic (<i>only pH glass</i>)</li> <li>■ Manual</li> </ul> <b>Factory setting</b> Fixed	<b>Fixed</b> You choose values from a list. This list depends on the setting for "Buffer manufacturer".  <b>Automatic (<i>only pH glass</i>)</b> The device recognizes the buffer automatically. The recognition depends on the setting for "Buffer manufacturer".  <b>Manual</b> You enter any two buffer values. These must differ in terms of their pH value.
Buffer manufacturer	Options <ul style="list-style-type: none"> <li>■ Endress+Hauser</li> <li>■ Ingold/Mettler</li> <li>■ DIN 19266</li> <li>■ DIN 19267</li> <li>■ Merck/Riedel</li> <li>■ Hamilton</li> <li>■ Special buffer</li> </ul> <b>Factory setting</b> Endress+Hauser	Temperature tables are stored internally in the unit for the following pH values: <ul style="list-style-type: none"> <li>■ Endress+Hauser 2.00 / 4.00 / 7.00 / (9.00) / 9.20 / 10.00 / 12.00</li> <li>■ Ingold/Mettler 2.00 / 4.01 / 7.00 / 9.21</li> <li>■ DIN 19266 1.68 / 4.01 / 6.86 / 9.18</li> <li>■ DIN 19267 1.09 / 4.65 / 6.79 / 9.23 / 12.75</li> <li>■ Merck/Riedel 2.00 / 4.01 / 6.98 / 8.95 / 12.00</li> <li>■ Hamilton 1.09 / 1.68 / 2.00 / 3.06 / 4.01 / 5.00 / 6.00 / 7.00 / 8.00 / 9.21 / 10.01 / 11.00 / 12.00</li> </ul>

 You have the possibility of defining two buffers of your own with the "Special buffer" option. For this purpose, two tables are displayed in which you can enter pH value/temperature value pairs.

**Calibration timer and calibration expiration date**

→ "Inputs: General/Frequently occurring functions" section →  98

**10.2.5 Diagnostics settings**

This menu branch is used for specifying warning limits, and for defining whether and how diagnostics tools should be used.

The associated diagnostics code is displayed for every setting.

**Sensor check system (only pH glass)**

The sensor check system (SCS) monitors the high impedance of the pH glass.

An alarm is issued if a minimum impedance value is undershot or a maximum impedance is exceeded.

- Glass breakage is the main reason for a drop in high impedance values.
- The reasons for increasing impedance values include:
  - Dry sensor
  - Worn pH glass membrane.

**Path: Menu/Setup/Inputs/pH/Extended setup/Diagnostics settings**

Function	Options	Info
▶ Glass impedance (SCS)	0 to 10000 MΩ	Specify your limit values for monitoring the impedance of the pH glass.
Function	Options <ul style="list-style-type: none"> <li>■ On</li> <li>■ Off</li> </ul> <b>Factory setting</b> On	<b>On</b> SCS operates with the following settings for the warning and alarm limits. <b>Off</b> SCS is switched off.
Upper alarm limit	<b>Factory setting</b> 2000 MΩ	Diagnostics code and associated message text: 124 "Sensor glass"
Upper warning limit	<b>Factory setting</b> 1600 MΩ	Diagnostics code and associated message text: 125 "Sensor glass"
Lower warning limit	<b>Factory setting</b> 1 MΩ	Diagnostics code and associated message text: 123 "Sensor glass"
Lower alarm limit	<b>Factory setting</b> 0 MΩ	Diagnostics code and associated message text: 122 "Sensor glass"

**Slope (only pH)**

The slope characterizes the sensor condition. The bigger the deviation from the ideal value (59 mV/pH) the poorer the condition of the sensor.

**Path: Menu/Setup/Inputs/pH/Extended setup/Diagnostics settings**

Function	Options	Info
▶ Slope	5.00 to 99.00 mV/pH	Specify your limit values for slope monitoring.
Warning limit	<b>Factory setting</b> 55.00 mV/pH	Associated diagnostics code and message text: 509 "Sensor calib."

## Zero point (only pH glass) or Operating point (only pH ISFET)

### *pH glass sensors*

The zero point characterizes the condition of the sensor reference. The bigger the deviation from the ideal value (pH 7.00) the poorer the condition. This can be caused by KCl dissolving away or reference contamination.

**Path: Menu/Setup/Inputs/pH/Extended setup/Diagnostics settings**

Function	Options	Info
▶ Zero point ( <i>pH glass</i> ) Operating point ( <i>pH ISFET</i> )	<b>pH glass</b> -2.00 to 16.00  <b>pH ISFET</b> -950 mV to 950 mV	Specify your limit values for zero point or operating point monitoring.
Upper warning limit	<b>Factory setting</b> pH 8.00 / 300 mV	Associated diagnostics code and message text: 505 "Sensor calib." (pH glass) 515 "Sensor calib." (pH ISFET)
Lower warning limit	<b>Factory setting</b> pH 6.00 / -300 mV	Associated diagnostics code and message text: 507 "Sensor calib." (pH glass) 517 "Sensor calib." (pH ISFET)

## Sensor condition check (only pH glass)

Sensor condition check (SCC) monitors the electrode status and the degree of electrode aging. The electrode status is updated after every calibration.

The main reasons for a deteriorating electrode status are:

- Glass membrane blocked or dry
- Diaphragm (reference) blocked

Remedial action

- ▶ Clean or regenerate the sensor.
- ▶ Replace the sensor if this does not have the desired effect.

**Path: Menu/Setup/Inputs/pH/Extended setup/Diagnostics settings**

Function	Options	Info
▶ Sensor Condition Check		The function can only be switched on or off. It uses internal limit values.
Function	Options <ul style="list-style-type: none"> <li>■ On</li> <li>■ Off</li> </ul> <b>Factory setting</b> On	Diagnostics code and associated message text: 127 "SCC sufficient" 126 "SCC bad"

## ORP-Meas value (only ORP)

You can specify limit values in order to monitor your process. A diagnostics message is displayed if the limits are exceeded or undershot.

**Path:** Menu/Setup/Inputs/ORP/Extended setup/Diagnostics settings

Function	Options	Info
▶ ORP-Meas value		Specify your limit values for monitoring the measured value.
Upper warning limit	<b>Factory setting</b> 900 mV	Diagnostics code and associated message text: 942 "Process value"
Lower warning limit	<b>Factory setting</b> -900 mV	Diagnostics code and associated message text: 943 "Process value"

## Process check system

→ "Inputs: General/Frequently occurring functions" section →  98

## Limits operating hours

The total operating time of the sensor and its use under extreme conditions is monitored. If the operating time exceeds the defined threshold values, the device issues a corresponding diagnostics message.

 Each sensor has a limited life expectancy which heavily depends on the operating conditions. If you specify warning limits for operating times under extreme conditions, you can guarantee the operation of your measuring point without any downtime by performing maintenance tasks in time.

**Path:** Menu/Setup/Inputs/pH or ORP/Extended setup/Diagnostics settings

Function	Options	Info
▶ Limits operating hours		Specify your limit values for monitoring the number of operating hours under extreme conditions.
 The range of adjustment for the operating hours alarm and warning limits is generally 1 to 50000 h.		
Function	Options <ul style="list-style-type: none"> <li>■ On</li> <li>■ Off</li> </ul> <b>Factory setting</b> On	<b>On</b> The operation of the sensor under extreme conditions is monitored, recorded in the sensor and diagnostics messages are displayed on the controller. <b>Off</b> No diagnostics messages. However, the time the sensor operates under extreme conditions is recorded in the sensor and can be read in the sensor information in the diagnostics menu.

**Path: Menu/Setup/Inputs/pH or ORP/Extended setup/Diagnostics settings**

Function	Options	Info
▶ Operating time		Total operating time of the sensor
Warning limit	<b>Factory setting</b> 10000 h	Diagnostics code and associated message text: 199 "Operating time"
▶ Operation > 80°C		
Warning limit	<b>Factory setting</b> 10000 h	Diagnostics code and associated message text: 193 "Operating time"
▶ Operation > 100°C		
Warning limit	<b>Factory setting</b> 10000 h	Diagnostics code and associated message text: 194 "Operating time"
▶ Operation < -300 mV		<i>only pH</i>
Warning limit	<b>Factory setting</b> 10000 h	Diagnostics code and associated message text: 180 "Operating time"
▶ Operation > 300 mV		<i>only pH</i>
Warning limit	<b>Factory setting</b> 10000 h	Diagnostics code and associated message text: 179 "Operating time"

**Delta slope (only pH)**

The device determines the difference in slope between the last calibration and the penultimate calibration, and issues a warning or an alarm depending on the setting configured. The difference is an indicator for the condition of the sensor. The greater the change, the greater the wear experienced by the pH-sensitive glass membrane as a result of chemical corrosion or abrasion.

**Path: Menu/Setup/Inputs/pH/Extended setup/Diagnostics settings**

Function	Options	Info
▶ Delta slope	0.10 to 10.00 mV/pH	Specify your limit values for monitoring the slope differential.
Function	Options <input type="checkbox"/> On <input type="checkbox"/> Off <b>Factory setting</b> Off	
Warning limit	<b>Factory setting</b> 5.00 mV/pH	Diagnostics code and associated message text: 518 "Sensor calib."

## Delta zero point (only pH glass) or Delta operating point (only pH ISFET)

The device determines the difference between the last calibration and the penultimate calibration, and issues a warning or an alarm depending on the setting configured. The difference is an indicator for the condition of the sensor. The following applies to pH glass electrodes: The greater the change, the greater the wear experienced by the reference as a result of contaminating ions or KCl dissolving away.

**Path: Menu/Setup/Inputs/pH/Extended setup/Diagnostics settings**

Function	Options	Info
<ul style="list-style-type: none"> <li>▶ Delta zero point (<i>pH glass</i>)</li> <li>▶ Delta operating point (<i>pH ISFET</i>)</li> </ul>	<p><b>pH glass</b> pH 0.00 to 2.00</p> <p><b>pH ISFET</b> 0 to 950 mV</p>	Specify your limit values for monitoring the zero point or operating point differential.
Function	<p>Options</p> <ul style="list-style-type: none"> <li>■ On</li> <li>■ Off</li> </ul> <p><b>Factory setting</b> Off</p>	
Warning limit	<p><b>Factory setting</b> pH 0.50 / 25 mV</p>	<p>Diagnostics code and associated message text:</p> <p>520 "Sensor calib." (pH glass)</p> <p>522 "Sensor calib." (pH ISFET)</p>

## Sterilizations

→ "Inputs: General/Frequently occurring functions" section → 98

## Diagnostic behavior

→ "Inputs: General/Frequently occurring functions" section → 98

### 10.2.6 Tag control

→ "Inputs: General/Frequently occurring functions" section → 98

### 10.2.7 Sensor replacement

→ "Inputs: General/Frequently occurring functions" section → 98

### 10.2.8 Data processing factory setting

→ "Inputs: General/Frequently occurring functions" section → 98



# 11 Inputs: Conductivity

## 11.1 Basic settings

### 11.1.1 Sensor identification

Path: Menu/Setup/Inputs/<Sensor type>

Function	Options	Info
Channel	Options <ul style="list-style-type: none"> <li>■ On</li> <li>■ Off</li> </ul> <b>Factory setting</b> On	<b>On</b> The channel display is switched on in the measuring mode <b>Off</b> The channel is not displayed in the measuring mode, regardless of whether a sensor is connected or not.
Sensor type	Read only (Only available if a sensor is connected)	Connected sensor type
Order code		Order code of the connected sensor

### 11.1.2 Damping

→ "Inputs: General/Frequently occurring functions" section →  98

### 11.1.3 Manual hold

→ "Inputs: General/Frequently occurring functions" section →  98

### 11.1.4 Operating mode and cell constant

Path: Menu/Setup/Inputs/Conductivity

Function	Options	Info
Operating mode	Options <ul style="list-style-type: none"> <li>■ Conductivity</li> <li>■ Resistance <i>(only Cond c)</i></li> <li>■ Concentration <i>(only Cond i)</i></li> <li>■ TDS <i>(only Cond c)</i></li> </ul> <b>Factory setting</b> Conductivity	Alternatively to the conductivity, you can also measure the resistivity and the total dissolved solids (TDS) parameter with a <b>conductive conductivity sensor</b> . Alternatively to the conductivity, you can determine the concentration of the medium with an <b>inductive conductivity sensor</b> . <b>TDS</b> TDS stands for all the organic and inorganic substances in the water in ionic, molecular or microgranular (<2 µm) form. Compared with laboratory methods (gravimetric analysis), TDS measurement via the conductivity value delivers a maximum measured error of less than 10%.
Cell constant	Read only (Only available if a sensor is connected)	The cell constant of the connected sensor is displayed (→ sensor certificate)

### 11.1.5 Installation factor (only inductive sensors)

Path: Menu/Setup/Inputs/Conductivity

Function	Options	Info
Inst. factor	Read only (Only available if a sensor is connected)	Displays the current value. Only changes with a calibration.

In confined installation conditions, the wall affects conductivity measurement in the liquid. The installation factor compensates for this effect. The transmitter corrects the cell constant by multiplying by the installation factor.

The size of the installation factor depends on the diameter and the conductivity of the pipe nozzle, as well as the distance between the sensor and the wall.

If there is a sufficient distance between the wall and the sensor ( $a > 15 \text{ mm}$  (0.59"), from DN 80) the installation factor  $f$  does not have to be taken into consideration ( $f = 1.00$ ).

If distances from the wall are smaller, the installation factor is bigger for electrically insulating pipes ( $f > 1$ ), and smaller for electrically conductive pipes ( $f < 1$ ).

It can be measured using calibration solutions, or a close approximation determined from the following diagram.

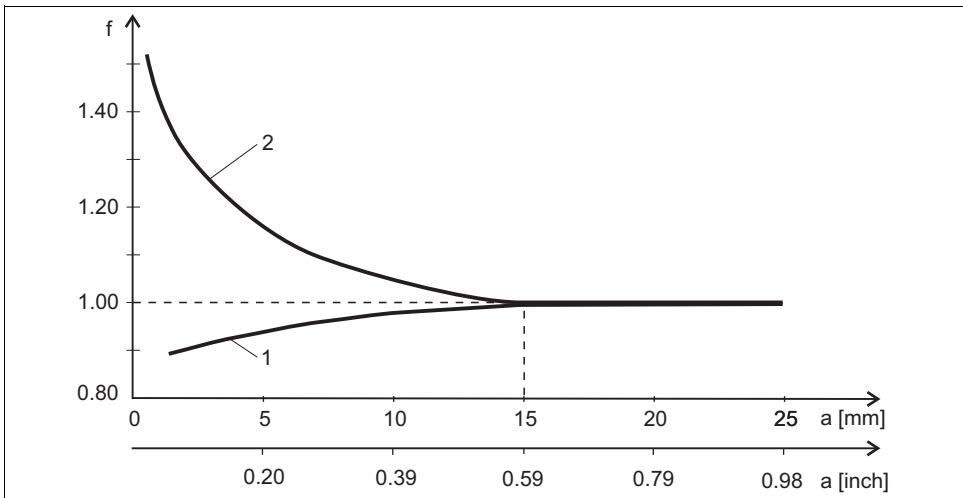

Fig. 14: Relation between the installation factor  $f$  and the wall distance

- 1 Electrically conductive pipe wall
- 2 Electrically insulating pipe wall

### 11.1.6 Concentration table (only inductive sensors)

Path: Menu/Setup/Inputs/Conductivity

Function	Options	Info
Conc. Table ( <i>Operating mode=Concentration</i> )	Options <ul style="list-style-type: none"> <li>■ NaOH 0..15%</li> <li>■ HCl</li> <li>■ HNO3</li> <li>■ H2SO4 0..30%</li> <li>■ H3PO4</li> <li>■ User table 1</li> <li>■ User table 2</li> <li>■ User table 3</li> <li>■ User table 4</li> </ul> <b>Factory setting</b> NaOH 0..15%	Concentration tables saved at the factory: NaOH: 0 to 15%, 0 to 100 °C HCl: 0 to 20%, 0 to 80 °C HNO <sub>3</sub> : 0 to 25%, 0 to 90 °C H <sub>2</sub> SO <sub>4</sub> : 0 to 25%, 0 to 100 °C H <sub>3</sub> PO <sub>4</sub> : 0 to 40%, 0 to 90 °C
Temp. comp. mode ( <i>Operating mode=Concentration</i> )	Options <ul style="list-style-type: none"> <li>■ with temp. comp</li> <li>■ without temp. comp</li> </ul> <b>Factory setting</b> with temp. comp	Only select "without temp. comp" in very small temperature ranges. In all other cases, select "with temp. comp".
Table name ( <i>Conc. Table=one of the user tables</i> )	Customized text, 16 characters	Assign a meaningful name to the selected table.
▶ Edit table ( <i>Conc. Table=one of the user tables</i> )	3-column table	Assign conductivity and concentration value pairs for a specific temperature.
Conc. unit ( <i>Operating mode=Concentration</i> )	<b>Read only</b> %	This is for information purposes only. No options are available.

Example of a concentration table:

Conductivity (uncompensated)	Concentration	Temperature
1.000 mS/cm	0.000 mg/l	0.00 °C
2.000 mS/cm	0.000 mg/l	100.00 °C
100.0 mS/cm	3.000 mg/l	0.00 °C
300.0 mS/cm	3.000 mg/l	100.00 °C



Values must be constantly increasing or decreasing.

### 11.1.7 Unit and format

Path: Menu/Setup/Inputs/Conductivity

Function	Options	Info
Main value format	Options <ul style="list-style-type: none"> <li>■ Auto</li> <li>■ #</li> <li>■ #.#</li> <li>■ #.##</li> <li>■ #.###</li> </ul> <b>Factory setting</b> Auto	Specify the number of decimal places.
Cond. unit <i>(Operating mode=Conductivity)</i>  Unit <i>(Operating mode=Resistance)</i>	Options Conductivity/resistance <ul style="list-style-type: none"> <li>■ Auto / Auto</li> <li>■ <math>\mu\text{S}/\text{cm}</math> / <math>\text{M}\Omega\text{m}</math></li> <li>■ <math>\text{mS}/\text{cm}</math> / <math>\text{M}\Omega\text{cm}</math></li> <li>■ <math>\text{S}/\text{cm}</math> / <math>\text{k}\Omega\text{cm}</math></li> <li>■ <math>\mu\text{S}/\text{m}</math> / <math>\text{k}\Omega\text{m}</math></li> <li>■ <math>\text{mS}/\text{m}</math> / <math>\Omega\text{m}</math></li> <li>■ <math>\text{S}/\text{m}</math> / <math>\Omega\text{cm}</math></li> </ul> <b>Factory setting</b> Auto / Auto	The picklist depends on the operating mode. You can either choose from units for conductivity or units for resistivity. Since there are no options for concentration measurement, this function is not displayed for such measurements.

### 11.1.8 Temperature compensation

Temperature coefficient  $\alpha$  = change in the conductivity per degree of temperature change:

$$\kappa(T) = \kappa(T_0)(1 + \alpha(T - T_0))$$

$\kappa(T)$  ... conductivity at process temperature T

$\kappa(T_0)$  ... conductivity at reference temperature  $T_0$

The temperature coefficient depends both on the chemical composition of the solution and the temperature itself.

Path: Menu/Setup/Inputs/Conductivity

Function	Options	Info
Alpha ref. temp.	-5.0 to 100.0 °C (23.0 to 212.0 °F) <b>Factory setting</b> 25.0 °C (77.0 °F)	Reference temperature for calculating the temperature-compensated conductivity  The alpha coefficients and alpha reference temperatures of Endress+Hauser calibration solutions can be found in the documentation enclosed.
Temp. source	Options <ul style="list-style-type: none"> <li>■ Sensor</li> <li>■ Manual</li> </ul> <b>Factory setting</b> Sensor	Decide how you want to compensate the medium temperature: <ul style="list-style-type: none"> <li>■ Automatically using the temperature sensor of your sensor</li> <li>■ Manually by entering the medium temperature</li> </ul>

## Path: Menu/Setup/Inputs/Conductivity

Function	Options	Info
Medium temperature (Temp. source=Manual)	-50.0 to 250.0 °C (-58.0 to 482.0 °F)  <b>Factory setting</b> 25.0 °C (77 °F)	Enter the temperature of your medium.
Compensation (Operating mode=Conductivity)	Options <ul style="list-style-type: none"> <li>■ None</li> <li>■ Linear</li> <li>■ NaCl (IEC 746-3)</li> <li>■ Water ISO7888</li> <li>■ UPW NaCl</li> <li>■ UPW HCl</li> <li>■ User table 1</li> <li>■ User table 2</li> <li>■ User table 3</li> <li>■ User table 4</li> </ul> <b>Factory setting</b> Linear	Various methods are available to compensate for the temperature dependency. Depending on your process, decide which type of compensation you want to use. Alternatively, you can also select "None" and thus measure uncompensated conductivity.

**Linear temperature compensation**

The change between two temperature points is taken to be constant, i.e.  $\alpha = \text{const}$ . The value for alpha is stored in the sensor and is recalculated for each calibration. You already specified the related reference temperature in this menu.

**NaCl compensation**

In the case of NaCl compensation (as per IEC 60746), a fixed non-linear curve specifying the relationship between the temperature coefficient and temperature is saved in the device. This curve applies to low concentrations of up to approx. 5 % NaCl.

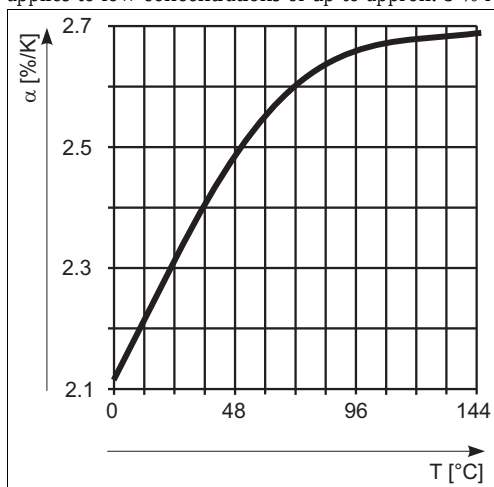

### Compensation for natural water

A non-linear function in accordance with ISO 7888 is saved in the device for temperature compensation in natural water.

### Ultrapure water compensation (for conductive sensors)

Algorithms for pure and ultrapure water are stored in the device. These algorithms take the dissociation of the water and its temperature dependency into account. They are used for conductivity values up to approx. 100 µS/cm.

- UPW NaCl: Optimized for pH-neutral contamination.
- UPW HCl: Optimized for measuring the acid conductivity downstream of a cation exchanger. Also suitable for ammonia (NH<sub>3</sub>) and caustic soda (NaOH).

### User-defined tables

You can save a function that takes the properties of your specific process into account. To do so, determine the value pairs made up of the temperature T and conductivity κ with:

- κ(T<sub>0</sub>) for the reference temperature T<sub>0</sub>
- κ(T) for the temperatures that occur in the process

Use the following formula to calculate the α values for the temperatures that are relevant in your process:

$$\alpha = \frac{100\%}{\kappa(T_0)} \cdot \frac{\kappa(T) - \kappa(T_0)}{T - T_0}; T \neq T_0$$

Values must be constantly increasing or decreasing.

#### Path: Menu/Setup/Inputs/Conductivity

Function	Options	Info
Temp. comp. mode <i>(Compensation=one of the user tables)</i>	Options <ul style="list-style-type: none"> <li>■ Conductivity</li> <li>■ Coeff. Alpha</li> </ul> Factory setting Conductivity	<b>Conductivity</b> You specify the temperature, conductivity and uncompensated conductivity. Recommended for large measuring ranges and small measured values. <b>Coeff. Alpha</b> As the value pairs, you specify an alpha value and the related temperature.
Table name <i>(Compensation=one of the user tables)</i>	Customized text, 16 characters	Assign a meaningful name to the selected table.
▶ Edit table <i>(Compensation=one of the user tables)</i>	<ul style="list-style-type: none"> <li>■ Temperature</li> <li>■ Conductivity</li> <li>■ Temperature comp. cond.</li> </ul> or <ul style="list-style-type: none"> <li>■ Temperature</li> <li>■ Coefficient alpha</li> </ul>	Maximum number of rows: 25 The type of table depends on the option under "Temp. comp. mode".

## 11.2 Extended setup

### 11.2.1 Temperature format

Path: Menu/Setup/Inputs/<Sensor type>/Extended setup

Function	Options	Info
Temperature format	Options <ul style="list-style-type: none"> <li>■ #.#</li> <li>■ #.##</li> </ul> Factory setting #.#	Select how many decimal places should be used to display the temperature.

### 11.2.2 Cleaning

→ "Inputs: General/Frequently occurring functions" section →  98

### 11.2.3 Diagnostics settings

This menu branch is used for specifying warning limits, and for defining whether and how diagnostics tools should be used.

The associated diagnostics code is displayed for every setting.

#### Process check system

→ "Inputs: General/Frequently occurring functions" section →  98

#### Limits operating hours

The total operating time of the sensor and its use under extreme conditions is monitored. If the operating time exceeds the defined threshold values, the device issues a corresponding diagnostics message.

-  Each sensor has a limited life expectancy which heavily depends on the operating conditions. If you specify warning limits for operating times under extreme conditions, you can guarantee the operation of your measuring point without any downtime by performing maintenance tasks in time.

**Path: Menu/Setup/Inputs/Conductivity/Extended setup/Diagnostics settings**

Function	Options	Info
▶ Limits operating hours		
 The range of adjustment for the operating hours alarm and warning limits is generally 1 to 50000 h.		
Function	Options ■ On ■ Off  <b>Factory setting</b> Off	<b>On</b> The operation of the sensor under extreme conditions is monitored, recorded in the sensor and diagnostics messages are displayed on the controller.  <b>Off</b> No diagnostics messages. However, the time the sensor operates under extreme conditions is recorded in the sensor and can be read in the sensor information in the diagnostics menu.
▶ Operating time		Total operating time of the sensor
Warning limit	<b>Factory setting</b> 10000 h	Diagnostics code and associated message text: 199 "Operating time"
▶ Operation > 80°C		
Warning limit	<b>Factory setting</b> 10000 h	Diagnostics code and associated message text: 193 "Operating time"
▶ Operation > 120°C		
<i>Only conductive sensors</i>		
Warning limit	<b>Factory setting</b> 10000 h	Diagnostics code and associated message text: 195 "Operating time"
▶ Operation > 125°C		
<i>Only inductive sensors</i>		
Warning limit	<b>Factory setting</b> 10000 h	Diagnostics code and associated message text: 196 "Operating time"
▶ Operation > 140°C		
<i>Only conductive sensors</i>		
Warning limit	<b>Factory setting</b> 10000 h	Diagnostics code and associated message text: 197 "Operating time"
▶ Operation > 150°C		
<i>Only inductive sensors</i>		
Warning limit	<b>Factory setting</b> 10000 h	Diagnostics code and associated message text: 198 "Operating time"
▶ Operation > 80°C < 100nS/cm		
<i>Only conductive sensors</i>		
Warning limit	<b>Factory setting</b> 10000 h	Diagnostics code and associated message text: 187 "Operating time"
▶ Operation < 5°C		
<i>Only inductive sensors</i>		
Warning limit	<b>Factory setting</b> 10000 h	Diagnostics code and associated message text: 188 "Operating time"



## Sterilizations

→ "Inputs: General/Frequently occurring functions" section →  98

## Diagnostic behavior

→ "Inputs: General/Frequently occurring functions" section →  98

### Polarization detection (only conductive sensors)

As a result of flow through the electrolyte/electrode interface, reactions take place here which result in additional voltage. These polarization effects limit the measuring range of conductive sensors. Sensor-specific compensation increases the level of accuracy at the measuring range limits.



The controller recognizes the Memosens sensor and automatically uses suitable compensation. You can view the measuring range limits of the sensor under Diagnostics/Sensor information/Sensor specifications.

**Path: Menu/Setup/Inputs/Conductivity/Extended setup/Diagnostics settings/Polarization detected**

Function	Options	Info
Polarization detected	Options <ul style="list-style-type: none"> <li>■ On</li> <li>■ Off</li> </ul> <b>Factory setting</b> Off	Diagnostics code and associated message text: 168 "Polarization"

### 11.2.4 Pharmaceutical water

Here you can make settings for monitoring pharmaceutical water in accordance with the United States Pharmacopeia (USP) or European Pharmacopeia (EP). The uncompensated conductivity value and the temperature are measured for the limit functions. The measured values are compared with the tables defined in the standards. If the limit is exceeded, an alarm is triggered. Furthermore, you can also set a preliminary alarm (warning limit) which signals undesired operating states before they occur.

**Path: Menu/Setup/Inputs/Conductivity/Extended setup/Diagnostics settings/Pharmacy-water**

Function	Options	Info
Function	Options <ul style="list-style-type: none"> <li>■ Off</li> <li>■ EP</li> <li>■ USP</li> </ul> <b>Factory setting</b> Off	The alarm values are stored in the device in accordance with USP or EP specifications. You define the warning limit as a % of the alarm value.
Warning limit	10.0 to 99.9 % <b>Factory setting</b> 80.0 %	Diagnostics code and associated message text: 915 "USP warning" If the value exceeds the USP or EP alarm values saved in the software, diagnostics message 914 "USP alarm" is displayed.

### **11.2.5 Tag control**

→ "Inputs: General/Frequently occurring functions" section →  98

### **11.2.6 Sensor replacement**

→ "Inputs: General/Frequently occurring functions" section →  98

### **11.2.7 Data processing factory setting**

→ "Inputs: General/Frequently occurring functions" section →  98

### **11.2.8 Sensor factory setting (only CLS50D)**

→ "Inputs: General/Frequently occurring functions" section →  98

## 12 Inputs: Oxygen

### 12.1 Basic settings

#### 12.1.1 Sensor identification

Path: Menu/Setup/Inputs/<Sensor type>

Function	Options	Info
Channel	Options <ul style="list-style-type: none"> <li>■ On</li> <li>■ Off</li> </ul> <b>Factory setting</b> On	<b>On</b> The channel display is switched on in the measuring mode <b>Off</b> The channel is not displayed in the measuring mode, regardless of whether a sensor is connected or not.
Sensor type	Read only (Only available if a sensor is connected)	Connected sensor type
Order code		Order code of the connected sensor

#### 12.1.2 Main value

Path: Menu/Setup/Inputs/DO

Function	Options	Info
Main value	Options <ul style="list-style-type: none"> <li>■ Concentration liquid</li> <li>■ Concentration gaseous</li> <li>■ Saturation</li> <li>■ Partial pressure</li> <li>■ Raw value nA (only Oxygen (amp.))</li> <li>■ Raw value <math>\mu</math>s (only Oxygen (opt.))</li> </ul> <b>Factory setting</b> Concentration liquid	Decide how you want to display the main value. Other functions, such as the setting for the unit, depend on this setting.

#### 12.1.3 Damping

→ "Inputs: General/Frequently occurring functions" section →  98

## 12.1.4 Unit

Path: Menu/Setup/Inputs/DO

Function	Options	Info
Unit <i>Main value="Concentration liquid" or "Concentration gaseous"</i>	Options ( <i>Main value="Concentration liquid"</i> ) <ul style="list-style-type: none"> <li>■ mg/l</li> <li>■ µg/l</li> <li>■ ppm</li> <li>■ ppb</li> </ul> Options ( <i>Main value="Concentration gaseous"</i> ) <ul style="list-style-type: none"> <li>■ %Vol</li> <li>■ ppmVol (<i>Main value="Concentration gaseous"</i>)</li> </ul> <b>Factory setting</b> mg/l %Vol	

## 12.1.5 Manual hold

→ "Inputs: General/Frequently occurring functions" section → 98

## 12.2 Extended setup

### 12.2.1 Temperature compensation (only amperometric sensors)

Path: Menu/Setup/Inputs/DO/Extended setup

Function	Options	Info
Temp. compensation	Options <ul style="list-style-type: none"> <li>■ Automatic</li> <li>■ Manual</li> </ul> <b>Factory setting</b> Automatic	Decide how you want to compensate the medium temperature: <ul style="list-style-type: none"> <li>■ Automatically using the temperature sensor of your sensor This means that the temperature is always compensated based on the current temperature value.</li> <li>■ Manually by entering the medium temperature This means that the measured value is always compensated against the value entered, e.g. for inlet and outlet monitoring in a cooling facility.</li> </ul>
Temperature ( <i>Temp. compensation=Manual</i> )	0.0 to 80.0 °C (32.0 to 176.0 °F) <b>Factory setting</b> 20.0 °C (68 °F)	Enter the temperature of your medium, or another temperature which you want to use as a reference temperature.

## 12.2.2 Measured value formats

Path: Menu/Setup/Inputs/DO or Chlorine/Extended setup<sup>1)</sup>

Function	Options	Info
Main value format	Options <ul style="list-style-type: none"> <li>■ #.#</li> <li>■ #.##</li> <li>■ #.###</li> <li>■ #</li> </ul> <b>Factory setting</b> #.#	Specify the number of decimal places for displaying the main measured value.
Temperature format	Options <ul style="list-style-type: none"> <li>■ #.#</li> <li>■ #.##</li> </ul> <b>Factory setting</b> #.#	Select how many decimal places should be used to display the temperature.

1) In the case of chlorine, the sequence of the two menu functions is reversed

## 12.2.3 Medium compensation (in the process)

Path: Menu/Setup/Inputs/DO/Extended setup

Function	Options	Info
Medium pressure	Options <ul style="list-style-type: none"> <li>■ Process pressure</li> <li>■ Air pressure</li> <li>■ Altitude</li> </ul> <b>Factory setting</b> Air pressure	
Altitude <i>Medium pressure="Altitude"</i>	-300 to 4000 m <b>Factory setting</b> 0 m	Enter the altitude <b>or</b> the average air pressure (mutually dependent values). If you specify the altitude, the average air pressure is calculated from the barometric altitude formula and vice versa. If you are compensating using the process pressure, enter the pressure in your process here. The pressure is then independent of the altitude.
Air pressure or Process pressure	<i>Medium pressure="Air pressure"</i> 500 to 1200 hPa  <i>Medium pressure="Process pressure"</i> 500 to 9999 hPa <b>Factory setting</b> 1013 hPa	
Salinity	0 to 40 g/kg <b>Factory setting</b> 0 g/kg	The influence of salt content on oxygen measurement is compensated with this function. Example: sea water measurement as per Copenhagen Standard (30 g/kg).

## 12.2.4 Cleaning

Path: Menu/Setup/Inputs/<Sensor type>/Extended setup

Function	Options	Info
Cleaning	Options <ul style="list-style-type: none"> <li>■ None</li> <li>■ Cleaning 1</li> <li>■ Cleaning 2</li> <li>■ Cleaning 3</li> <li>■ Cleaning 4</li> </ul> <b>Factory setting</b> None	Select a cleaning program.  This program is executed if: <ul style="list-style-type: none"> <li>■ A diagnostics message is present at the channel <b>and</b></li> <li>■ A cleaning process has been specified for this message (→ "Inputs/Diagnostics settings/Diag. behavior").</li> </ul>

 You define the cleaning programs in the "Setup/Additional functions/Cleaning" menu.

## 12.2.5 Calibration settings

### Stability criteria

You define the permitted measured value fluctuation which must not be exceeded in a certain timeframe during calibration.

If the permitted difference is exceeded, calibration is not permitted and is aborted automatically.

Path: Menu/Setup/Inputs/Oxygen/Extended setup/Calib. settings

Function	Options	Info
▶ Stability criteria		
Delta signal	0.1 to 2.0 %  <b>Factory setting</b> 0.2 %	Permitted measured value fluctuation during calibration. Referenced to the raw value in nA in the case of amperometric sensors, and referenced to the partial pressure in the case of optical sensors.
Delta temperature	0.10 to 2.00 K  <b>Factory setting</b> 0.50 K	Permitted temperature fluctuation during calibration
Duration	5 to 60 s  <b>Factory setting</b> 20 s	Timeframe within which the permitted range for measured value fluctuation should not be exceeded

## Medium compensation (during calibration)

Path: Menu/Setup/Inputs/DO/Extended setup/Calib. settings

Function	Options	Info
Medium pressure	Options <ul style="list-style-type: none"> <li>■ Process pressure</li> <li>■ Air pressure</li> <li>■ Altitude</li> </ul> <b>Factory setting</b> Air pressure	
Altitude <i>Medium pressure="Altitude"</i>	-300 to 4000 m <b>Factory setting</b> 0 m	Enter the altitude <b>or</b> the average air pressure (mutually dependent values). If you specify the altitude, the average air pressure is calculated from the barometric altitude formula and vice versa.
Air pressure or Process pressure	<i>Medium pressure="Air pressure"</i> 500 to 1200 hPa  <i>Medium pressure="Process pressure"</i> 500 to 9999 hPa <b>Factory setting</b> 1013 hPa	If you are compensating using the process pressure, enter the pressure in your process here. The pressure is then independent of the altitude.
Rel. hum. (air variable)	0 to 100 % <b>Factory setting</b> 100 %	

### Calibration timer and calibration expiration date

→ "Inputs: General/Frequently occurring functions" section →  98

#### 12.2.6 Diagnostics settings

This menu branch is used for specifying warning limits, and for defining whether and how diagnostics tools should be used.

The associated diagnostics code is displayed for every setting.

## Slope

The (relative) slope characterizes the sensor condition. Decreasing values indicate electrolyte exhaustion. You can control when the electrolyte should be replaced by specifying limit values and the diagnostics messages these limit values trigger.

**Path: Menu/Setup/Inputs/DO/Extended setup/Diagnostics settings**

Function	Options	Info
► Slope	0.0 to 200.0 %	Specify the limit values for slope monitoring in your sensor.
Upper warning limit	<b>Factory setting</b> 140.0 %	Diagnostics code and associated message text: 511 "Sensor calib."
Lower warning limit	<b>Factory setting</b> 60.0 %	Diagnostics code and associated message text: 509 "Sensor calib."

## Delta slope (only amperometric sensors)

The device determines the difference in slope between the last calibration and the penultimate calibration, and issues a warning or an alarm depending on the setting configured. The difference is an indicator for the condition of the sensor. An increasing change indicates the formation of buildup on the sensor diaphragm or electrolyte contamination. Replace the diaphragm and electrolyte as specified in the instructions in the sensor operating manual.

**Path: Menu/Setup/Inputs/DO/Extended setup/Diagnostics settings**

Function	Options	Info
► Delta slope	0.0 to 50.0 %	Specify the limit values for monitoring the slope differential.
Function	Options <ul style="list-style-type: none"> <li>■ On</li> <li>■ Off</li> </ul> <b>Factory setting</b> On	
Warning limit	<b>Factory setting</b> 5.0 %	Diagnostics code and associated message text: 518 "Sensor calib."



## Zero point (only amperometric sensors)

-  The zero point corresponds to the sensor signal that is measured in a medium in the absence of oxygen. You can calibrate the zero point in water that is free from oxygen or in high-purity nitrogen. This improves accuracy in the trace range.

**Path: Menu/Setup/Inputs/DO/Extended setup/Diagnostics settings**

Function	Options	Info
▶ Zero point	0.0 to 10.0 nA	Specify the limit values for zero point monitoring in your sensor.
Warning limit	<b>Factory setting</b> 3.0 nA	Diagnostics code and associated message text: 513 "Zero Warn"

## Delta zero point (only amperometric sensors)

The device determines the difference between the last calibration and the penultimate calibration, and issues a warning or an alarm depending on the setting configured. The difference is an indicator for the condition of the sensor. Increasing differences indicate the formation of buildup on the cathode. Clean or replace the cathode as specified in the instructions in the sensor operating manual.

**Path: Menu/Setup/Inputs/DO/Extended setup/Diagnostics settings**

Function	Options	Info
▶ Delta zero point	0.0 to 10 nA	Specify your limit values for monitoring the zero point differential.
Function	Options <ul style="list-style-type: none"> <li>■ On</li> <li>■ Off</li> </ul> <b>Factory setting</b> Off	
Warning limit	<b>Factory setting</b> 1.0 nA	Diagnostics code and associated message text: 520 "Sensor calib."

### Cap calibrations (only amperometric sensors)

 The calibration counters in the sensor make a distinction between sensor calibrations and calibrations with the membrane cap currently used. If this cap is replaced, only the (cap) counter is reset.

**Path: Menu/Setup/Inputs/DO/Extended setup/Diagnostics settings**

Function	Options	Info
▶ Number of cap calibrations		Specify how many calibrations may be performed with a membrane cap before the cap has to be replaced. The number depends heavily on the process and must be determined individually.
Function	Options <ul style="list-style-type: none"> <li>■ On</li> <li>■ Off</li> </ul> <b>Factory setting</b> Off	
Warning limit	0 to 1000 <b>Factory setting</b> 6	Diagnostics code and associated message text: 535 "Sensor check"

### Cap sterilizations (only sterilizable, amperometric sensors)

 The sterilization counters in the sensor make a distinction between the sensor and the membrane cap currently used. If this cap is replaced, only the (cap) counter is reset.

**Path: Menu/Setup/Inputs/DO/Extended setup/Diagnostics settings**

Function	Options	Info
▶ Number of cap sterilizations		Specify how many sterilizations may be performed with a membrane cap before the cap has to be replaced. The number depends heavily on the process and must be determined individually.
Function	Options <ul style="list-style-type: none"> <li>■ On</li> <li>■ Off</li> </ul> <b>Factory setting</b> Off	
Warning limit	0 to 100 <b>Factory setting</b> 25	Diagnostics code and associated message text: 109 "Sterilizat. cap"

### Sterilizations (only sterilizable sensors)

→ "Inputs: General/Frequently occurring functions" section →  98

### Process check system

→ "Inputs: General/Frequently occurring functions" section →  98

## Limits operating hours

The total operating time of the sensor and its use under extreme conditions is monitored. If the operating time exceeds the defined threshold values, the device issues a corresponding diagnostics message.

-  Each sensor has a limited life expectancy which heavily depends on the operating conditions. If you specify warning limits for operating times under extreme conditions, you can guarantee the operation of your measuring point without any downtime by performing maintenance tasks in time.

**Path: Menu/Setup/Inputs/DO/Extended setup/Diagnostics settings**

Function	Options	Info
▶ Limits operating hours		
 The range of adjustment for the operating hours alarm and warning limits is generally 1 to 50000 h.		
Function	Options <ul style="list-style-type: none"> <li>■ On</li> <li>■ Off</li> </ul> <b>Factory setting</b> Off	<b>On</b> The operation of the sensor under extreme conditions is monitored, recorded in the sensor and diagnostics messages are displayed on the controller. <b>Off</b> No diagnostics messages. However, the time the sensor operates under extreme conditions is recorded in the sensor and can be read in the sensor information in the diagnostics menu.
▶ Operating time		Total operating time of the sensor
Warning limit	<b>Factory setting</b> 10000 h	Diagnostics code and associated message text: 199 "Operating time"
▶ Operation < 5°C		
Warning limit	<b>Factory setting</b> 10000 h	Diagnostics code and associated message text: 188 "Operating time"
▶ Operation > 5°C		
Warning limit	<b>Factory setting</b> 10000 h	Diagnostics code and associated message text: 189 "Operating time"
▶ Operation > 25°C		
Warning limit	<b>Factory setting</b> 10000 h	Diagnostics code and associated message text: 190 "Operating time"
▶ Operation > 30°C		
Warning limit	<b>Factory setting</b> 10000 h	Diagnostics code and associated message text: 191 "Operating time"
▶ Operation > 40°C		
Warning limit	<b>Factory setting</b> 10000 h	Diagnostics code and associated message text: 192 "Operating time"

**Path: Menu/Setup/Inputs/DO/Extended setup/Diagnostics settings**

Function	Options	Info
▶ Operation > 80°C		<i>Only COS22D</i>
Warning limit	<b>Factory setting</b> 10000 h	Diagnostics code and associated message text: 193 "Operating time"
▶ (Operation above first specified nA value)		<i>Only amperometric sensors, sensor-specific limit</i> – COS22D: >15 nA – COS51D: >30 nA
Warning limit	<b>Factory setting</b> 10000 h	Diagnostics code and associated message text: 183 "Operating time" (COS22D) 184 "Operating time" (COS51D)
▶ (Operation above second specified nA value)		<i>Only amperometric sensors, sensor-specific limit</i> – COS22D: >50 nA – COS51D: >160 nA
Warning limit	<b>Factory setting</b> 10000 h	Diagnostics code and associated message text: 185 "Operating time" (COS22D) 186 "Operating time" (COS51D)
▶ Operation < 25 μs		<i>Only optical sensors (μS = fluorescence decay time, raw value of optical measurement)</i>
Warning limit	<b>Factory setting</b> 10000 h	Diagnostics code and associated message text: 181 "Operating time"
▶ Operation > 40 μs		<i>Only optical sensors</i>
Warning limit	<b>Factory setting</b> 10000 h	Diagnostics code and associated message text: 182 "Operating time"

**Diagnostic behavior**

→ "Inputs: General/Frequently occurring functions" section →  98

**12.2.7 Tag control**

→ "Inputs: General/Frequently occurring functions" section →  98

**12.2.8 Sensor replacement**

→ "Inputs: General/Frequently occurring functions" section →  98

**12.2.9 Data processing factory setting**

→ "Inputs: General/Frequently occurring functions" section →  98

**12.2.10 Sensor factory setting (only COS61D)**

→ "Inputs: General/Frequently occurring functions" section →  98

## 13 Inputs: Chlorine

### 13.1 Basic settings

#### 13.1.1 Sensor identification

Path: Menu/Setup/Inputs/<Sensor type>

Function	Options	Info
Channel	Options <ul style="list-style-type: none"> <li>■ On</li> <li>■ Off</li> </ul> <b>Factory setting</b> On	<b>On</b> The channel display is switched on in the measuring mode <b>Off</b> The channel is not displayed in the measuring mode, regardless of whether a sensor is connected or not.
Sensor type	Read only (Only available if a sensor is connected)	Connected sensor type
Order code		Order code of the connected sensor

#### 13.1.2 Main value

Path: Menu/Setup/Inputs/Chlorine

Function	Options	Info
Main value	Options <ul style="list-style-type: none"> <li>■ Concentration</li> <li>■ Sensor current (nA)</li> </ul> <b>Factory setting</b> Concentration	Decide how you want to display the main value.

#### 13.1.3 Damping

→ "Inputs: General/Frequently occurring functions" section →  98

#### 13.1.4 Manual hold

→ "Inputs: General/Frequently occurring functions" section →  98

## 13.1.5 Unit

Path: Menu/Setup/Inputs/Chlorine

Function	Options	Info
Unit <i>Main value="Concentration liquid"</i>	Options <ul style="list-style-type: none"> <li>■ mg/l</li> <li>■ µg/l</li> <li>■ ppm</li> <li>■ ppb</li> </ul> <b>Factory setting</b> mg/l	

## 13.2 Extended setup

### 13.2.1 Measured value formats

Path: Menu/Setup/Inputs/DO or Chlorine/Extended setup<sup>1)</sup>

Function	Options	Info
Main value format	Options <ul style="list-style-type: none"> <li>■ #.#</li> <li>■ #.##</li> <li>■ #.###</li> <li>■ #</li> </ul> <b>Factory setting</b> #.##	Specify the number of decimal places for displaying the main measured value.
Temperature format	Options <ul style="list-style-type: none"> <li>■ #.#</li> <li>■ #.##</li> </ul> <b>Factory setting</b> #.#	Select how many decimal places should be used to display the temperature.

1) In the case of chlorine, the sequence of the two menu functions is reversed

## 13.2.2 Medium compensation (in the process)

Path: Menu/Setup/Inputs/Chlorine/Extended setup

Function	Options	Info
Medium comp. (pH)	Options <ul style="list-style-type: none"> <li>■ Off</li> <li>■ On</li> </ul> <b>Factory setting</b> On	<b>Off</b> The concentration measured value is calculated as HClO (=free available chlorine).  <b>On</b> The pH value is used to calculate a cumulative concentration value from HClO and ClO <sup>-</sup> (=total chlorine).
Mode <i>Medium comp. (pH) = "On"</i>	Options <ul style="list-style-type: none"> <li>■ Fixed value</li> <li>■ Measured value</li> </ul> <b>Factory setting</b> Fixed value	Decide whether you want to specify a fixed pH value for calculating the total chlorine or whether the measured value of a pH sensor attached to another input should be used.
Fixed pH <i>Mode = "Fixed value"</i>	4.00 to 9.00 pH <b>Factory setting</b> 7.20 pH	Useful for media with constant pH values  Enter the pH value of your medium which you determined with a reference measurement.
Associated pH-sensor <i>Mode = "Measured value"</i>	Select the pH sensor <b>Factory setting</b> None	Preferred method for media with varying pH values  Select the sensor input with the connected pH sensor. The measured value of the sensor is then continuously used to calculate the total chlorine.
Temp. compensation	Options <ul style="list-style-type: none"> <li>■ Off</li> <li>■ Automatic</li> <li>■ Manual</li> </ul> <b>Factory setting</b> Automatic	Decide whether and how you want to compensate the medium temperature: <ul style="list-style-type: none"> <li>■ No compensation</li> <li>■ Automatically using the temperature sensor of your sensor</li> <li>■ Manually by entering the medium temperature</li> </ul>
Medium temperature <i>(Temp. compensation = Manual)</i>	-5.0 to 50.0 °C (23.0 to 122.0 °F) <b>Factory setting</b> 20.0 °C (68 °F)	Enter the temperature of your medium.

### 13.2.3 Cleaning

→ "Inputs: General/Frequently occurring functions" section →  98

### 13.2.4 Calibration settings

#### Calibration timer and calibration expiration date

→ "Inputs: General/Frequently occurring functions" section →  98

## Stability criteria

You define the permitted measured value fluctuation which must not be exceeded in a certain timeframe during calibration.

If the permitted difference is exceeded, calibration is not permitted and is aborted automatically.

**Path: Menu/Setup/Inputs/Chlorine/Extended setup/Calib. settings**

Function	Options	Info
▶ Stability criteria		
Delta signal	0.1 to 5.0 % <b>Factory setting</b> 1 %	Permitted measured value fluctuation during calibration. (referenced to the raw value in nA)
Delta temperature	0.10 to 2.00 K <b>Factory setting</b> 0.50 K	Permitted temperature fluctuation during calibration
Duration	5 to 100 s <b>Factory setting</b> 20 s	Timeframe within which the permitted range for measured value fluctuation should not be exceeded

## 13.2.5 Diagnostics settings

This menu branch is used for specifying warning limits, and for defining whether and how diagnostics tools should be used.

The associated diagnostics code is displayed for every setting.

### Slope

The (relative) slope characterizes the sensor condition. Decreasing values indicate electrolyte exhaustion. You can control when the electrolyte should be replaced by specifying limit values and the diagnostics messages these limit values trigger.

**Path: Menu/Setup/Inputs/Chlorine/Extended setup/Diagnostics settings**

Function	Options	Info
▶ Slope	3.0 to 500.0 %	Specify the limit values for slope monitoring in your sensor.
Upper warning limit	<b>Factory setting</b> 200.0 %	Diagnostics code and associated message text: 511 "Sensor calib."
Lower warning limit	<b>Factory setting</b> 25.0 %	Diagnostics code and associated message text: 509 "Sensor calib."



## Delta slope

The device determines the difference in slope between the last calibration and the penultimate calibration, and issues a warning or an alarm depending on the setting configured. The difference is an indicator for the condition of the sensor. An increasing change indicates the formation of buildup on the sensor diaphragm or electrolyte contamination. Replace the diaphragm and electrolyte as specified in the instructions in the sensor operating manual.

**Path: Menu/Setup/Inputs/Chlorine/Extended setup/Diagnostics settings**

Function	Options	Info
▶ Delta slope	1 to 15 %	Specify the limit values for monitoring the slope differential.
Function	Options <ul style="list-style-type: none"> <li>■ On</li> <li>■ Off</li> </ul> <b>Factory setting</b> Off	
Warning limit	<b>Factory setting</b> 5 %	Diagnostics code and associated message text: 518 "Sensor calib."

## Zero point

The zero point corresponds to the sensor signal that is measured in a medium in the absence of chlorine. You can calibrate the zero point in water that is free from chlorine. This improves accuracy in the trace range.

**Path: Menu/Setup/Inputs/Chlorine/Extended setup/Diagnostics settings**

Function	Options	Info
▶ Zero point	0.0 to 3.2 nA	Specify the limit values for zero point monitoring in your sensor.
Warning limit	<b>Factory setting</b> 2.0 nA	Diagnostics code and associated message text: 513 "Zero Warn"

## Delta zero point

The device determines the difference between the last calibration and the penultimate calibration, and issues a warning or an alarm depending on the setting configured. The difference is an indicator for the condition of the sensor. Increasing differences indicate the formation of buildup on the cathode. Clean the cathode as specified in the instructions in the sensor operating manual.

**Path:** Menu/Setup/Inputs/Chlorine/Extended setup/Diagnostics settings

Function	Options	Info
▶ Delta zero point	0.0 to 3.2 nA	Specify your limit values for monitoring the zero point differential.
Function	Options <ul style="list-style-type: none"> <li>■ On</li> <li>■ Off</li> </ul> <b>Factory setting</b> On	
Warning limit	<b>Factory setting</b> 1.0 nA	Diagnostics code and associated message text: 520 "Sensor calib."

## Number of cap calibrations

**Path:** Menu/Setup/Inputs/Chlorine/Extended setup/Diagnostics settings

Function	Options	Info
▶ Number of cap calibrations		Specify how many calibrations may be performed with a membrane cap before the cap has to be replaced. The number depends heavily on the process and must be determined individually.
Function	Options <ul style="list-style-type: none"> <li>■ On</li> <li>■ Off</li> </ul> <b>Factory setting</b> Off	
Warning limit	1 to 20 <b>Factory setting</b> 6	Diagnostics code and associated message text: 535 "Sensor check"

## Process check system

→ "Inputs: General/Frequently occurring functions" section →  98

## Limits operating hours

The total operating time of the sensor and its use under extreme conditions is monitored. If the operating time exceeds the defined threshold values, the device issues a corresponding diagnostics message.

-  Each sensor has a limited life expectancy which heavily depends on the operating conditions. If you specify warning limits for operating times under extreme conditions, you can guarantee the operation of your measuring point without any downtime by performing maintenance tasks in time.

### Path: Menu/Setup/Inputs/Chlorine/Extended setup/Diagnostics settings

Function	Options	Info
▶ Limits operating hours		
 The range of adjustment for the operating hours alarm and warning limits is generally 1 to 100000 h.		
Function	Options <ul style="list-style-type: none"> <li>■ On</li> <li>■ Off</li> </ul> <b>Factory setting</b> Off	<b>On</b> The operation of the sensor under extreme conditions is monitored, recorded in the sensor and diagnostics messages are displayed on the controller. <b>Off</b> No diagnostics messages. However, the time the sensor operates under extreme conditions is recorded in the sensor and can be read in the sensor information in the diagnostics menu.
▶ Operating time		Total operating time of the sensor
Warning limit	<b>Factory setting</b> 10000 h	Diagnostics code and associated message text: 199 "Operating time"
▶ Operation > 15°C		
Warning limit	<b>Factory setting</b> 10000 h	Diagnostics code and associated message text: 178 "Operating time"
▶ Operation > 30°C		
Warning limit	<b>Factory setting</b> 10000 h	Diagnostics code and associated message text: 191 "Operating time"
▶ Operation > 20 nA		
Warning limit	<b>Factory setting</b> 10000 h	Diagnostics code and associated message text: 177 "Operating time"
▶ Operation > 100 nA		
Warning limit	<b>Factory setting</b> 10000 h	Diagnostics code and associated message text: 176 "Operating time"

## Electrolyte counter

The electrolyte consumption is calculated on the basis of the amount of charge that penetrates the sensor diaphragm.

### The following applies for the sensor CCS142D gilt:

Half the chloride would be consumed and the entire dihydrogen phosphate would be converted to monohydrogen phosphate in an electrolyte filling (4 ml) at 20 000 000  $\mu\text{As}$  (=20 As). This would render the electrolyte and the sensor unusable.

In the interests of predictive maintenance, you should replace the electrolyte at 10 000 000  $\mu\text{As}$ , and preferably at 5 000 000  $\mu\text{As}$ . 25%-50% of the dihydrogen phosphate is then consumed.

The calculation presumes that the buffer of the electrolyte is only changed by the electrochemical conversion of hypochlorous acid. It does not take the penetration of acids and bases into the sensor into account.

Depending on the application it can be necessary to change the electrolyte before a charge of 5 As is reached.

**Path: Menu/Setup/Inputs/Chlorine/Extended setup/Diagnostics settings**

Function	Options	Info
▶ Electrolyte counter	0 to 2000000 $\mu\text{As}$	
Function	Options <ul style="list-style-type: none"> <li>■ On</li> <li>■ Off</li> </ul> <b>Factory setting</b> On	
Warning limit	<b>Factory setting</b> 1000000 $\mu\text{As}$	Diagnostics code and associated message text: 534 "Sensor calib."

## Diagnostic behavior

→ "Inputs: General/Frequently occurring functions" section →  98

### 13.2.6 Tag control

→ "Inputs: General/Frequently occurring functions" section →  98

### 13.2.7 Sensor replacement

→ "Inputs: General/Frequently occurring functions" section →  98

### 13.2.8 Data processing factory setting

→ "Inputs: General/Frequently occurring functions" section →  98

## 14 Inputs: Turbidity and solids

### 14.1 Basic settings

#### 14.1.1 Sensor identification

Path: Menu/Setup/Inputs/<Sensor type>

Function	Options	Info
Channel	Options <ul style="list-style-type: none"> <li>■ On</li> <li>■ Off</li> </ul> <b>Factory setting</b> On	<b>On</b> The channel display is switched on in the measuring mode <b>Off</b> The channel is not displayed in the measuring mode, regardless of whether a sensor is connected or not.
Sensor type	Read only (Only available if a sensor is connected)	Connected sensor type
Order code		Order code of the connected sensor

#### 14.1.2 Application

The sensor is precalibrated on leaving the factory. As such, it can be used in a wide range of applications (e.g. clear water measurement) without the need for additional calibration. The factory calibration is based on a three-point calibration of a reference sample.

The factory calibration cannot be deleted and can be retrieved at any time. All other calibrations - performed as customer calibrations - are referenced to this factory calibration.



Calibration data records are saved under an individual name. You can add your own data records during each calibration. These are then available for selection under "Application".

Path: Menu/Setup/Inputs/Turbidity

Function	Options	Info
Application type	Options <ul style="list-style-type: none"> <li>■ Clear water</li> <li>■ Solid</li> </ul> <b>Factory setting</b> Clear water	Preselection for saved calibration data records
Application	Depends on the sensor	Select a saved calibration data record

#### 14.1.3 Damping

→ "Inputs: General/Frequently occurring functions" section → 98

#### 14.1.4 Manual hold

→ "Inputs: General/Frequently occurring functions" section → 98

## 14.2 Extended setup

### 14.2.1 Measured value formats

Path: Menu/Setup/Inputs/Turbidity/Extended setup

Function	Options	Info
Temperature format	Options <ul style="list-style-type: none"> <li>■ #.#</li> <li>■ #.##</li> </ul> <b>Factory setting</b> #.#	Select how many decimal places should be used to display the temperature.
Main value format	Options <ul style="list-style-type: none"> <li>■ #.#</li> <li>■ #.##</li> <li>■ #.###</li> <li>■ #</li> </ul> <b>Factory setting</b> #.#	Specify the number of decimal places for the main value.
Unit	Options Application="Formacine" <ul style="list-style-type: none"> <li>■ FNU</li> <li>■ NTU</li> </ul> Options All apart from "Formacine" <ul style="list-style-type: none"> <li>■ g/l</li> <li>■ ppm</li> <li>■ %TS</li> </ul> <b>Factory setting</b> FNU g/l	Select the unit for the main measured value.

### 14.2.2 Cleaning

→ "Inputs: General/Frequently occurring functions" section → 98

### 14.2.3 Calibration settings

#### Calibration timer and calibration expiration date

→ "Inputs: General/Frequently occurring functions" section → 98

## Stability criteria

You define the permitted measured value fluctuation which must not be exceeded in a certain timeframe during calibration.

If the permitted difference is exceeded, calibration is not permitted and is aborted automatically.

**Path: Menu/Setup/Inputs/Turbidity/Extended setup/Calib. settings**

Function	Options	Info
▶ Stability criteria		
Delta turbidity	0.1 to 5.0 % <b>Factory setting</b> 2.0 %	Permitted measured value fluctuation during calibration
Delta temperature	0.10 to 2.00 K <b>Factory setting</b> 0.50 K	Permitted temperature fluctuation during calibration
Duration	0 to 100 s <b>Factory setting</b> 20 s	Timeframe within which the permitted range for measured value fluctuation should not be exceeded

### 14.2.4 Diagnostics settings

This menu branch is used for specifying warning limits, and for defining whether and how diagnostics tools should be used.



The associated diagnostics code is displayed for every setting.

#### Limits operating hours

The total operating time of the sensor and its use under extreme conditions is monitored. If the operating time exceeds the defined threshold values, the device issues a corresponding diagnostics message.

-  Each sensor has a limited life expectancy which heavily depends on the operating conditions. If you specify warning limits for operating times under extreme conditions, you can guarantee the operation of your measuring point without any downtime by performing maintenance tasks in time.

**Path: Menu/Setup/Inputs/Turbidity/Extended setup/Diagnostics settings**

Function	Options	Info
▶ Limits operating hours		Specify your limit values for monitoring the number of operating hours under extreme conditions.
 The range of adjustment for the operating hours alarm and warning limits is generally 1 to 50000 h.		
Function	Options ■ On ■ Off  <b>Factory setting</b> Off	<b>On</b> The operation of the sensor under extreme conditions is monitored, recorded in the sensor and diagnostics messages are displayed on the controller.  <b>Off</b> No diagnostics messages. However, the time the sensor operates under extreme conditions is recorded in the sensor and can be read in the sensor information in the diagnostics menu.
▶ Operating time		Total operating time of the sensor
Warning limit	<b>Factory setting</b> 10000 h	Diagnostics code and associated message text: 199 "Operating time"
 The names of the menu functions in brackets depend on the sensor specification. For this reason, they cannot be specified here.		
▶ (Operation below specified temperature limit, e.g. < -5 °C)		
Warning limit	<b>Factory setting</b> 10000 h	Diagnostics code and associated message text: 935 "Process temp."
▶ (Operation above specified temperature limit, e.g. > 55 °C)		
Warning limit	<b>Factory setting</b> 10000 h	Diagnostics code and associated message text: 934 "Process temp."
▶ (Operation below specified limit value, e.g. < 0 FNU)		
Warning limit	<b>Factory setting</b> 10000 h	Diagnostics code and associated message text: 943 "Process value"
▶ (Operation above specified limit value e.g. > 10000 FNU)		
Warning limit	<b>Factory setting</b> 10000 h	Diagnostics code and associated message text: 942 "Process value"

**Process check system**

→ "Inputs: General/Frequently occurring functions" section →  98

**Sensor operating hours**

The data displayed here are the current hours the device has been in operation under extreme conditions. You cannot make any changes. You can only read the values.  
The same data can be found in the Diagnostics menu.



**Diagnostic behavior**

→ "Inputs: General/Frequently occurring functions" section →  98

**14.2.5 Tag control**

→ "Inputs: General/Frequently occurring functions" section →  98

**14.2.6 Sensor replacement**

→ "Inputs: General/Frequently occurring functions" section →  98

**14.2.7 Data processing factory setting**

→ "Inputs: General/Frequently occurring functions" section →  98

**14.2.8 Sensor factory setting**

→ "Inputs: General/Frequently occurring functions" section →  98

# 15 Inputs: SAC

## 15.1 Basic settings

### 15.1.1 Sensor identification

Path: Menu/Setup/Inputs/<Sensor type>

Function	Options	Info
Channel	Options <ul style="list-style-type: none"> <li>■ On</li> <li>■ Off</li> </ul> <b>Factory setting</b> On	<b>On</b> The channel display is switched on in the measuring mode <b>Off</b> The channel is not displayed in the measuring mode, regardless of whether a sensor is connected or not.
Sensor type	Read only (Only available if a sensor is connected)	Connected sensor type
Order code		Order code of the connected sensor

### 15.1.2 Application

 Calibration data records are saved under an individual name in the sensor. A new sensor is calibrated at the factory and thus already has appropriate data records. You can add your own data records during each calibration. These are then available for selection under "Application".

Path: Menu/Setup/Inputs/SAC

Function	Options	Info
Basic application	Options <ul style="list-style-type: none"> <li>■ SAC</li> <li>■ Transm.</li> <li>■ Absorption</li> <li>■ COD</li> <li>■ TOC</li> <li>■ DOC</li> <li>■ BOD</li> </ul> <b>Factory setting</b> SAC	Preselection for saved calibration data records
Application	Options <ul style="list-style-type: none"> <li>■ Factory calib.</li> <li>■ 5 other data records</li> </ul> <b>Factory setting</b> Factory calib.	Select a saved calibration data record

### 15.1.3 Damping

→ "Inputs: General/Frequently occurring functions" section →  98

### 15.1.4 Manual hold

→ "Inputs: General/Frequently occurring functions" section → 98

## 15.2 Extended setup

### 15.2.1 Measured value formats

Path: Menu/Setup/Inputs/SAC/Extended setup

Function	Options	Info
Temperature format	Options <ul style="list-style-type: none"> <li>■ #.#</li> <li>■ #.##</li> </ul> <b>Factory setting</b> #.#	Select how many decimal places should be used to display the temperature.
Main value format	Options <ul style="list-style-type: none"> <li>■ #.#</li> <li>■ #.##</li> <li>■ #.###</li> <li>■ #</li> </ul> <b>Factory setting</b> #.#	Specify the number of decimal places for the main value.
Unit	Options <ul style="list-style-type: none"> <li>■ None</li> <li>■ %</li> <li>■ mg/l</li> <li>■ ppm</li> <li>■ 1/m</li> </ul> <b>Factory setting</b> Depends on "Basic application"	The unit of the main value depends on the basic application selected. Depending on this setting only certain units are available for selection.

### 15.2.2 Cleaning

→ "Inputs: General/Frequently occurring functions" section → 98

### 15.2.3 Calibration settings

#### Calibration timer and calibration expiration date

→ "Inputs: General/Frequently occurring functions" section → 98

## Stability criteria

You define the permitted measured value fluctuation which must not be exceeded in a certain timeframe during calibration.

If the permitted difference is exceeded, calibration is not permitted and is aborted automatically.

**Path: Menu/Setup/Inputs/SAC/Extended setup/Calib. settings**

Function	Options	Info
▶ Stability criteria		
Delta SAC	0.1 to 5.0 % <b>Factory setting</b> 2.0 %	Permitted measured value fluctuation during calibration
Delta temperature	0.10 to 2.00 K <b>Factory setting</b> 0.50 K	Permitted temperature fluctuation during calibration
Duration	0 to 100 s <b>Factory setting</b> 10 s	Timeframe within which the permitted range for measured value fluctuation should not be exceeded

### 15.2.4 Diagnostics settings

This menu branch is used for specifying warning limits, and for defining whether and how diagnostics tools should be used.



The associated diagnostics code is displayed for every setting.

#### Limits operating hours

The total operating time of the sensor and its use under extreme conditions is monitored. If the operating time exceeds the defined threshold values, the device issues a corresponding diagnostics message.

 Each sensor has a limited life expectancy which heavily depends on the operating conditions. If you specify warning limits for operating times under extreme conditions, you can guarantee the operation of your measuring point without any downtime by performing maintenance tasks in time.

## Path: Menu/Setup/Inputs/SAC/Extended setup/Diagnostics settings

Function	Options	Info
▶ Limits operating hours		Specify your limit values for monitoring the number of operating hours under extreme conditions.
 The range of adjustment for the operating hours alarm and warning limits is generally 1 to 50000 h.		
Function	Options <ul style="list-style-type: none"> <li>■ On</li> <li>■ Off</li> </ul> <b>Factory setting</b> Off	<b>On</b> The operation of the sensor under extreme conditions is monitored, recorded in the sensor and diagnostics messages are displayed on the controller. <b>Off</b> No diagnostics messages. However, the time the sensor operates under extreme conditions is recorded in the sensor and can be read in the sensor information in the diagnostics menu.
▶ Operating time		Total operating time of the sensor
Warning limit	<b>Factory setting</b> 10000 h	Diagnostics code and associated message text: 199 "Operating time"
 The names of the menu functions in brackets depend on the sensor specification. For this reason, they cannot be specified here.		
▶ (Operation below specified temperature limit, e.g. < 5 °C)		
Warning limit	<b>Factory setting</b> 10000 h	Diagnostics code and associated message text: 935 "Process temp."
▶ (Operation above specified temperature limit, e.g. > 50 °C)		
Warning limit	<b>Factory setting</b> 10000 h	Diagnostics code and associated message text: 934 "Process temp."
▶ (Operation below specified limit value, e.g. < 50 mg/l)		
Warning limit	<b>Factory setting</b> 10000 h	Diagnostics code and associated message text: 170 "Process value"
▶ (Operation above specified limit value, e.g. > 200 mg/l)		
Warning limit	<b>Factory setting</b> 10000 h	Diagnostics code and associated message text: 169 "Process value"
▶ Filter change		
Warning limit	<b>Factory setting</b> 10000 h	Diagnostics code and associated message text: 157 "Filter change"
Alarm limit	<b>Factory setting</b> 15000 h	Diagnostics code and associated message text: 161 "Filter change"

**Path: Menu/Setup/Inputs/SAC/Extended setup/Diagnostics settings**

Function	Options	Info
▶ Lamp life		
Warning limit	<b>Factory setting</b> 35040 h	Diagnostics code and associated message text: 171 "Lamp change"
Alarm limit	<b>Factory setting</b> 36500 h	Diagnostics code and associated message text: 71 "Lamp change"

**Process check system**

→ "Inputs: General/Frequently occurring functions" section → 98

**Sensor operating hours**

The data displayed here are the current hours the device has been in operation under extreme conditions. You cannot make any changes. You can only read the values. The same data can be found in the Diagnostics menu.

**Diagnostic behavior**

→ "Inputs: General/Frequently occurring functions" section → 98

**15.2.5 Tag control**

→ "Inputs: General/Frequently occurring functions" section → 98

**15.2.6 Sensor replacement**

→ "Inputs: General/Frequently occurring functions" section → 98

**15.2.7 Data processing factory setting**

→ "Inputs: General/Frequently occurring functions" section → 98

**15.2.8 Sensor factory setting**

→ "Inputs: General/Frequently occurring functions" section → 98

## 16 Inputs: Nitrate

### 16.1 Basic settings

#### 16.1.1 Sensor identification

Path: Menu/Setup/Inputs/<Sensor type>

Function	Options	Info
Channel	Options <ul style="list-style-type: none"> <li>■ On</li> <li>■ Off</li> </ul> <b>Factory setting</b> On	<b>On</b> The channel display is switched on in the measuring mode <b>Off</b> The channel is not displayed in the measuring mode, regardless of whether a sensor is connected or not.
Sensor type	Read only (Only available if a sensor is connected)	Connected sensor type
Order code		Order code of the connected sensor

#### 16.1.2 Application

 Calibration data records are saved under an individual name in the nitrate sensor. A new sensor is calibrated at the factory and always has a corresponding data record. You can add additional data records during each calibration. These are then available for selection under "Application".

Path: Menu/Setup/Inputs/Nitrate

Function	Options	Info
Application	Depends on the sensor	Select a saved calibration data record

#### 16.1.3 Damping

→ "Inputs: General/Frequently occurring functions" section →  98

#### 16.1.4 Manual hold

→ "Inputs: General/Frequently occurring functions" section →  98

## 16.2 Extended setup

### 16.2.1 Measured value formats

Path: Menu/Setup/Inputs/Nitrate/Extended setup

Function	Options	Info
Temperature format	Options <ul style="list-style-type: none"> <li>■ #.#</li> <li>■ #.##</li> </ul> <b>Factory setting</b> #.#	Select how many decimal places should be used to display the temperature.
Main value format	Options <ul style="list-style-type: none"> <li>■ #.#</li> <li>■ #.##</li> <li>■ #.###</li> <li>■ #</li> </ul> <b>Factory setting</b> #.#	Specify the number of decimal places.
Unit	Options <ul style="list-style-type: none"> <li>■ mg/l NO3-N</li> <li>■ mg/l NO3</li> <li>■ ppm NO3-N</li> <li>■ ppm NO3</li> </ul> <b>Factory setting</b> mg/l NO3-N	Select the unit for the main measured value.

### 16.2.2 Cleaning

→ "Inputs: General/Frequently occurring functions" section →  98

### 16.2.3 Calibration settings

#### Calibration timer and calibration expiration date

→ "Inputs: General/Frequently occurring functions" section →  98



## Stability criteria

You define the permitted measured value fluctuation which must not be exceeded in a certain timeframe during calibration.

If the permitted difference is exceeded, calibration is not permitted and is aborted automatically.

**Path: Menu/Setup/Inputs/Nitrate/Extended setup/Calib. settings**

Function	Options	Info
▶ Stability criteria		
Delta nitrate	0.1 to 5.0 % <b>Factory setting</b> 2.0 %	Permitted measured value fluctuation during calibration
Delta temperature	0.10 to 2.00 °C 0.18 to 3.60 °F <b>Factory setting</b> 0.50 °C 0.90 °F	Permitted temperature fluctuation during calibration
Duration	0 to 100 s <b>Factory setting</b> 10 s	Timeframe within which the permitted range for measured value fluctuation should not be exceeded

## 16.2.4 Diagnostics settings

This menu branch is used for specifying warning limits, and for defining whether and how diagnostics tools should be used.



The associated diagnostics code is displayed for every setting.

### Limits operating hours

The total operating time of the sensor and its use under extreme conditions is monitored. If the operating time exceeds the defined threshold values, the device issues a corresponding diagnostics message.

-  Each sensor has a limited life expectancy which heavily depends on the operating conditions. If you specify warning limits for operating times under extreme conditions, you can guarantee the operation of your measuring point without any downtime by performing maintenance tasks in time.

**Path: Menu/Setup/Inputs/Nitrate/Extended setup/Diagnostics settings**

Function	Options	Info
▶ Limits operating hours		Specify your limit values for monitoring the number of operating hours under extreme conditions.
 The range of adjustment for the operating hours alarm and warning limits is generally 1 to 50000 h.		
Function	Options <ul style="list-style-type: none"> <li>■ On</li> <li>■ Off</li> </ul> <b>Factory setting</b> Off	<b>On</b> The operation of the sensor under extreme conditions is monitored, recorded in the sensor and diagnostics messages are displayed on the controller. <b>Off</b> No diagnostics messages. However, the time the sensor operates under extreme conditions is recorded in the sensor and can be read in the sensor information in the diagnostics menu.
▶ Operating time		Total operating time of the sensor
Warning limit	<b>Factory setting</b> 10000 h	Diagnostics code and associated message text: 199 "Operating time"
 The names of the menu functions in brackets depend on the sensor specification. For this reason, they cannot be specified here.		
▶ (Operation below specified temperature limit, e.g. < 5 °C)		
Warning limit	<b>Factory setting</b> 10000 h	Diagnostics code and associated message text: 935 "Process temp."
▶ (Operation above specified temperature limit, e.g. > 50 °C)		
Warning limit	<b>Factory setting</b> 10000 h	Diagnostics code and associated message text: 934 "Process temp."
▶ (Operation below specified limit value, e.g. < 50 mg/l)		
Warning limit	<b>Factory setting</b> 10000 h	Diagnostics code and associated message text: 943 "Process value"
▶ (Operation above specified limit value, e.g. > 200 mg/l)		
Warning limit	<b>Factory setting</b> 10000 h	Diagnostics code and associated message text: 942 "Process value"
▶ Filter change		
Warning limit	<b>Factory setting</b> 10000 h	Diagnostics code and associated message text: 157 "Filter change"
Alarm limit	<b>Factory setting</b> 15000 h	Diagnostics code and associated message text: 161 "Filter change"

Path: Menu/Setup/Inputs/Nitrate/Extended setup/Diagnostics settings

Function	Options	Info
▶ Lamp life		
Warning limit	<b>Factory setting</b> 35000 h	Diagnostics code and associated message text: 171 "Lamp change"
Alarm limit	<b>Factory setting</b> 36500 h	Diagnostics code and associated message text: 71 "Lamp change"

## Process check system

→ "Inputs: General/Frequently occurring functions" section →  98

## Sensor operating hours

The data displayed here are the current hours the device has been in operation under extreme conditions. You cannot make any changes. You can only read the values. The same data can be found in the Diagnostics menu.

## Diagnostic behavior

→ "Inputs: General/Frequently occurring functions" section →  98

### 16.2.5 Tag control

→ "Inputs: General/Frequently occurring functions" section →  98

### 16.2.6 Sensor replacement

→ "Inputs: General/Frequently occurring functions" section →  98

### 16.2.7 Data processing factory setting

→ "Inputs: General/Frequently occurring functions" section →  98

### 16.2.8 Sensor factory setting

→ "Inputs: General/Frequently occurring functions" section →  98

# 17 Inputs: ISE

## 17.1 Basic settings

### 17.1.1 Sensor identification

Path: Menu/Setup/Inputs/<Sensor type>

Function	Options	Info
Channel	Options <ul style="list-style-type: none"> <li>■ On</li> <li>■ Off</li> </ul> <b>Factory setting</b> On	<b>On</b> The channel display is switched on in the measuring mode <b>Off</b> The channel is not displayed in the measuring mode, regardless of whether a sensor is connected or not.
Sensor type	Read only (Only available if a sensor is connected)	Connected sensor type
Order code		Order code of the connected sensor

### 17.1.2 Main value

The main value can be any parameter which is returned by one of the electrodes in the ISE sensor.

Path: Menu/Setup/Inputs/ISE

Function	Options	Info
Main value	Options <ul style="list-style-type: none"> <li>■ Ammonium</li> <li>■ Nitrate</li> <li>■ Potassium</li> <li>■ Chloride</li> <li>■ pH</li> <li>■ ORP</li> </ul> <b>Factory setting</b> pH	Decide which parameter you want to display as the main value for the ISE channel.  Here, you can only choose from the electrodes which you configured via the electrode slot menus. At the factory, this is equivalent to the types of electrode that are actually installed in the ISE sensor.

### 17.1.3 Damping of the temperature value

The damping causes a floating average curve of the measured values over the time specified.

Path: Menu/Setup/Inputs/ISE

Function	Options	Info
Damping temp.	0 to 300 s <b>Factory setting</b> 0 s	Specify the damping for the temperature measurement.

### 17.1.4 Manual hold

→ "Inputs: General/Frequently occurring functions" section →  98

## 17.2 Extended setup

### 17.2.1 Temperature format

Path: Menu/Setup/Inputs/<Sensor type>/Extended setup

Function	Options	Info
Temperature format	Options <ul style="list-style-type: none"> <li>■ #.#</li> <li>■ #.##</li> </ul> Factory setting #.#	Select how many decimal places should be used to display the temperature.

### 17.2.2 Cleaning

→ "Inputs: General/Frequently occurring functions" section →  98

### 17.2.3 Diagnostic behavior

→ "Inputs: General/Frequently occurring functions" section →  98

### 17.2.4 Tag control

→ "Inputs: General/Frequently occurring functions" section →  98

### 17.2.5 Sensor replacement

→ "Inputs: General/Frequently occurring functions" section →  98

### 17.2.6 Data processing factory setting

→ "Inputs: General/Frequently occurring functions" section →  98

## 17.3 Electrode slot menus

### 17.3.1 Electrode slot

A CAS40D sensor has 4 electrode slots in total. Consequently, each of these slots has its own menu.

Make settings:

- ▶ Define the parameter for the slot (only slots 2-4).  
The 1st slot is always designated to the pH electrode. There is no way you can select another parameter for this slot.
- ▶ You can complete and assign the other 3 slots as you prefer.
- ▶ Specify the measured variable that should be output. No options can be selected for pH which is why the "Measured variable" function is not available for this parameter.

Options displayed for "Measured variable" with the following parameters:				
pH	Ammonium	Nitrate	Potassium	Chloride
-	<ul style="list-style-type: none"> <li>■ NH4-N</li> <li>■ NH4</li> </ul>	<ul style="list-style-type: none"> <li>■ NO3-N</li> <li>■ NO3</li> </ul>	<ul style="list-style-type: none"> <li>■ K</li> </ul>	<ul style="list-style-type: none"> <li>■ Cl</li> </ul>

#### NOTICE

#### Electrode (hardware) incorrectly assigned to the software menu

Unreliable measured values and malfunctions in the measuring point could result

- ▶ When assigning the slot in the software, make sure it matches the assignment in the CAS40D sensor.
- ▶ Example: You have connected the ammonium electrode to cable No. 2 in the CAS40D. In the "Slot 2:1 (ISE)" software menu then configure the ammonium parameter.

### 17.3.2 Damping

The damping causes a floating average curve of the measured values over the time specified.

Path: Menu/Setup/Inputs/ISE/Electrode slot

Function	Options	Info
Damping	0 to 600 s  <b>Factory setting</b> 0 s	Specify the damping of the main value of the electrode assigned to the slot.

### 17.3.3 Extended setup

#### Main value format

If the measured variable of the electrode slot is not your main value for the ISE input, it will be displayed with all the measured values in the measuring mode.

**Path:** Menu/Setup/Inputs/ISE/Extended setup

Function	Options	Info
Main value format	Options <ul style="list-style-type: none"> <li>■ #</li> <li>■ #.#</li> <li>■ #.##</li> </ul> <b>Factory setting</b> #.##	Specify the number of decimal places for the measured variable of the electrode slot.

#### Compensation (only ammonium and nitrate)

Depending on the selectivity of the ion-selective electrode vis-à-vis other ions (interference ions), and the concentration of these ions, such ions could also be interpreted as part of the measuring signal and thus cause measuring errors.

When measuring in wastewater, the potassium ion which is chemically similar to the ammonium ion can cause higher measured values.

The measured values for nitrate can be too high due to high concentrations of chloride.

To reduce measuring errors resulting from such cross-interference, the concentration of the potassium or chloride interference ion can be measured and compensated for with a suitable additional electrode.

## Path: Menu/Setup/Inputs/ISE/Extended setup

Function	Options	Info
Compensation	Options <ul style="list-style-type: none"> <li>■ Off</li> <li>■ On</li> </ul> <b>Factory setting</b> Off	If you want to use the compensation function, you must have installed a compensation electrode (potassium or chloride) in another electrode slot and have configured it in the software.
Offset	-14.00 to 14.00 pH -100 to 100 mg/l <b>Factory setting</b> 0.00 pH 0.00 mg/l	The offset compensates for a difference between a laboratory measurement and an online measurement which is caused by interference ions. Enter this value manually. If you are using a compensation electrode, keep the offset at zero.
Compensation type	Options <ul style="list-style-type: none"> <li>■ Chloride</li> <li>■ pH</li> <li>■ Potassium</li> <li>■ pH and potassium</li> </ul> <b>Factory setting</b> Chloride Potassium	The options depend on the parameter to be compensated. You compensate for chloride when using a nitrate electrode, while you can compensate for potassium and pH when using the ammonium electrode. The factory setting depends on the electrode used.
Comp. electrode	Select the slot	If you have installed and configured several compensation electrodes of the same type in the CAS40D sensor, you have to define which electrode is used for compensation here. Generally, you have a potassium or chloride electrode and Liquiline recognizes the right slot.
Selectivity coefficient	-10.00 to 10.00 <b>Factory setting</b> -2.00 (chloride) -0.85 (potassium)	The coefficients are empirical values.
Mode	Options <ul style="list-style-type: none"> <li>■ +</li> <li>■ -</li> </ul> <b>Factory setting</b> -	The standard setting (-) corrects a measured value that is too high as a result of the effect of interference ions.



## Calibration settings

### Stability criteria

Path: Menu/Setup/Inputs/ISE/<Electrode slot>Extended setup/Calib. settings

Function	Options	Info
Stability criteria	Options <ul style="list-style-type: none"> <li>■ Off</li> <li>■ Weak</li> <li>■ Medium</li> <li>■ Hard</li> </ul> <b>Factory setting</b> Off	The stability criteria are usually switched off. However, in the event of standard addition it is advisable to select "Medium" in order to achieve the stable measured values required for this type of calibration.

### Buffer recognition (only pH)

Path: Menu/Setup/Inputs/ISE/<Electrode slot>Extended setup/Calib. settings

Function	Options	Info
Buffer recognition	Options <ul style="list-style-type: none"> <li>■ Fixed</li> <li>■ Manual</li> </ul> <b>Factory setting</b> Fixed	<b>Fixed</b> You choose values from a list. This list depends on the setting for "Buffer manufacturer".  <b>Manual</b> You enter any two buffer values. These must differ in terms of their pH value.
Buffer manufacturer	Options <ul style="list-style-type: none"> <li>■ Endress+Hauser</li> <li>■ Ingold/Mettler</li> <li>■ DIN 19266</li> <li>■ DIN 19267</li> <li>■ Merck/Riedel</li> <li>■ Hamilton</li> <li>■ Special buffer</li> </ul> <b>Factory setting</b> Endress+Hauser	Temperature tables are stored internally in the unit for the following pH values: <ul style="list-style-type: none"> <li>■ Endress+Hauser 2.00 / 4.00 / 7.00 / (9.00) / 9.20 / 10.00 / 12.00</li> <li>■ Ingold/Mettler 2.00 / 4.01 / 7.00 / 9.21</li> <li>■ DIN 19266 1.68 / 4.01 / 6.86 / 9.18</li> <li>■ DIN 19267 1.09 / 4.65 / 6.79 / 9.23 / 12.75</li> <li>■ Merck/Riedel 2.00 / 4.01 / 6.98 / 8.95 / 12.00</li> <li>■ Hamilton 1.09 / 1.68 / 2.00 / 3.06 / 4.01 / 5.00 / 6.00 / 7.00 / 8.00 / 9.21 / 10.01 / 11.00 / 12.00</li> </ul>

 You have the possibility of defining two buffers of your own with the "Special buffer" option. For this purpose, two tables are displayed in which you can enter pH value/temperature value pairs.

*Standard addition (all except for pH)*

Different types of calibration are available to calibrate an ion-selective electrode. Initial settings only have to be made for the standard addition method.

**Path: Menu/Setup/Inputs/ISE/<Electrode slot>Extended setup/Calib. settings**

Function	Options	Info
▶ Standard addition		
Sampling volume	0.00 to 5000.00 ml <b>Factory setting</b> 1000.00 ml	Here, specify the sample volume which you use during the calibration.
Standard volume	0.00 to 100.00 ml <b>Factory setting</b> 1.00 ml	Volume of the added standard solution per addition step
Standard concentration	0.00 to 10.00 mol/l <b>Factory setting</b> 1.00 mol/l	Concentration of the standard solution
No. of steps	1 to 4 <b>Factory setting</b> 3	Number of addition steps (=measuring points of the calibration function)

*Calibration timer*

You can specify the calibration interval for the sensor here.

Once the time configured elapses, the "Calibration timer" diagnostics message appears on the display.

 The timer is reset automatically if you recalibrate the sensor.

**Path: Menu/Setup/Inputs/ISE/<Slot>/Extended setup/Calib. settings**

Function	Options	Info
Calibration timer	Options <ul style="list-style-type: none"> <li>■ Off</li> <li>■ On</li> </ul> <b>Factory setting</b> Off	Switches the function on or off
Calibration timer <i>Calibration timer="On"</i>	1 to 10000 h <b>Factory setting</b> 1000 h	Specify the time after which the timer should have timed out. Once this time has elapsed, the "Calib. Timer" diagnostics message, along with the code 102, appears on the display.

## Diagnostics settings

This menu branch is used for specifying warning limits, and for defining whether and how diagnostics tools should be used.

The associated diagnostics code is displayed for every setting.

### *Process check system*

→ "Inputs: General/Frequently occurring functions" section → 98

### *Slope (only pH)*

The slope characterizes the sensor condition. The bigger the deviation from the ideal value (100%, corresponds to -59 mV/pH) the poorer the condition of the sensor.

**Path: Menu/Setup/Inputs/ISE/Extended setup/Diagnostics settings**

Function	Options	Info
▶ Slope	80.00 to 100.00 %	Specify your limit values for slope monitoring.
Warning limit	<b>Factory setting</b> 90.00 %	Associated diagnostics code and message text: 509 "Sensor calib."

### *Zero point (only pH)*

The zero point characterizes the condition of the sensor reference. The bigger the deviation from the ideal value (pH 7.00) the poorer the condition. This can be caused by KCl dissolving away or reference contamination.

**Path: Menu/Setup/Inputs/ISE/Extended setup/Diagnostics settings**

Function	Options	Info
▶ Zero point ( <i>pH glass</i> )	-10.00 to 10.00	Specify your limit values for zero point or operating point monitoring.
Upper warning limit	<b>Factory setting</b> 2.50	Associated diagnostics code and message text: 505 "Sensor calib."
Lower warning limit	<b>Factory setting</b> -2.50	Associated diagnostics code and message text: 507 "Sensor calib."

*Delta slope (only pH)*

The device determines the difference in slope between the last calibration and the penultimate calibration, and issues a warning or an alarm depending on the setting configured. The difference is an indicator for the condition of the sensor. The greater the change, the greater the wear experienced by the pH-sensitive glass membrane as a result of chemical corrosion or abrasion.

**Path: Menu/Setup/Inputs/ISE/Extended setup/Diagnostics settings**

Function	Options	Info
▶ Delta slope	0.50 to 10.00 %	Specify your limit values for monitoring the slope differential.
Function	Options <input type="checkbox"/> On <input type="checkbox"/> Off  <b>Factory setting</b> Off	
Warning limit	<b>Factory setting</b> 2.5 %	Diagnostics code and associated message text: 518 "Sensor calib."

*Delta zero point (only pH)*

The device determines the difference between the last calibration and the penultimate calibration, and issues a warning or an alarm depending on the setting configured. The difference is an indicator for the condition of the sensor. The following applies to pH glass electrodes: The greater the change, the greater the wear experienced by the reference as a result of contaminating ions or KCl dissolving away.

**Path: Menu/Setup/Inputs/ISE/Extended setup/Diagnostics settings**

Function	Options	Info
▶ Delta zero point	0.00 to 5.00	Specify your limit values for monitoring the zero point or operating point differential.
Function	Options <input type="checkbox"/> On <input type="checkbox"/> Off  <b>Factory setting</b> Off	
Warning limit	<b>Factory setting</b> 1.00	Diagnostics code and associated message text: 520 "Sensor calib."

## 17.4 Limits operating hours

The total operating time of the sensor and its use under extreme conditions is monitored. If the operating time exceeds the defined threshold values, the device issues a corresponding diagnostics message.

-  Each sensor has a limited life expectancy which heavily depends on the operating conditions. If you specify warning limits for operating times under extreme conditions, you can guarantee the operation of your measuring point without any downtime by performing maintenance tasks in time.

Path: Menu/Setup/Inputs/ISE

Function	Options	Info
▶ Limits operating hours		Specify your limit values for monitoring the number of operating hours under extreme conditions.
	The range of adjustment for the operating hours alarm and warning limits is generally 1 to 50000 h.	
Function	Options <ul style="list-style-type: none"> <li>■ On</li> <li>■ Off</li> </ul> <b>Factory setting</b> Off	<b>On</b> The operation of the sensor under extreme conditions is monitored, recorded in the sensor and diagnostics messages are displayed on the controller. <b>Off</b> No diagnostics messages. However, the time the sensor operates under extreme conditions is recorded in the sensor and can be read in the sensor information in the diagnostics menu.
▶ Operating time		Total operating time of the sensor
Warning limit	<b>Factory setting</b> 36000 h	Diagnostics code and associated message text: 199 "Operating time"
▶ Operation > 30°C		
Warning limit	<b>Factory setting</b> 36000 h	Diagnostics code and associated message text: 191 "Operating time"
▶ Operation > 40°C		
Warning limit	<b>Factory setting</b> 36000 h	Diagnostics code and associated message text: 192 "Operating time"

# 18 Inputs: Interface

## 18.1 Basic settings

 The CUS71D sensor is not detected automatically. It must be selected manually (Current sensor). During initial commissioning, data are recorded and calculated for 3 to 5 minutes before a measured value is displayed.

Path: Menu/Setup/Inputs/UIS

Function	Options	Info
Sensor operation	Options <ul style="list-style-type: none"> <li>■ Scan for memosens sensor</li> <li>■ Current sensor</li> </ul> <b>Factory setting</b> Current sensor	<b>Scan for memosens sensor</b> Searches for Memosens sensors  <b>Current sensor</b> Connected sensor is used
Wiper function	Options <ul style="list-style-type: none"> <li>■ Off</li> <li>■ On</li> </ul> <b>Factory setting</b> On	Only for sensor version with wiper function
Wiper timing	1 to 240 min <b>Factory setting</b> 10 min	Only for sensor version with wiper function
Turbidity measurement	Options <ul style="list-style-type: none"> <li>■ Off</li> <li>■ On</li> </ul> <b>Factory setting</b> On	Only for sensor version with integrated turbidity measurement and wiper function
Turbidity unit	Options <ul style="list-style-type: none"> <li>■ FNU</li> <li>■ NTU</li> </ul> <b>Factory setting</b> FNU	Only for sensor version with integrated turbidity measurement and wiper function

## 18.2 Manual hold

→ "Inputs: General/Frequently occurring functions" section →  98

## 18.3 Tank configuration

The mounting location is defined by the tank depth and the sensor zero point. The accuracy of the measurement results depends on the accuracy of these settings.

 Since the data in the sensor are overwritten with each change, data input might be delayed.

**Path: Menu/Setup/Inputs/UIS/Tank configuration**

Function	Options	Info
Blanket definition	Options <ul style="list-style-type: none"> <li>■ Interface level</li> <li>■ Interface range</li> </ul> <b>Factory setting</b> Interface level	Type of measurement that should be displayed and calculated:  <b>Interface level</b> Distance from the basin floor to the interface, measuring direction from bottom to top  <b>Interface range</b> Distance from the water line to the interface, measuring direction from top to bottom
Unit of measure	Options <ul style="list-style-type: none"> <li>■ m</li> <li>■ cm</li> <li>■ ft</li> <li>■ inch</li> </ul> <b>Factory setting</b> m	Any change to the unit is automatically accepted in all the displays.
Tank depth	0.4 to 10.0 m (1.4 to 32.8 ft)  <b>Factory setting</b> 8.0 m (26.2 ft)	Distance from the water level to the basin floor
Zero adjust	0.4 to 10.0 m (1.4 to 32.8 ft)  <b>Factory setting</b> 0.4 m (1.3 ft)	Distance from the water level to the sensor diaphragm
Blanking zone	Options <ul style="list-style-type: none"> <li>■ Off</li> <li>■ On</li> </ul> <b>Factory setting</b> Off	Permanent echo signals above and below a search window are blanked as interference signals.
Upper window limit	0.0 m to Lower window limit (1.4ft ...)  <b>Factory setting</b> 0.3 m (1.0 ft)	Distance to the water line below which the system should search for a separation zone. Permanent echo signals <b>above</b> this value are blanked out as interference signals.
Lower window limit	Upper window limit to 11.0 m (to 32.8 ft)  <b>Factory setting</b> 3.3 m (10.8 ft)	Distance to the water line Permanent echo signals <b>below</b> this value are blanked out as interference signals.

## 18.4 Sensor signal

Change the factory settings in this menu if you discover incorrect measurements.

**Path:** Menu/Setup/Inputs/UIS/Sensor signal

Function	Options	Info
Acoustic control	Options <ul style="list-style-type: none"> <li>■ Manual</li> <li>■ Automatic</li> </ul> <b>Factory setting</b> Automatic	Controls the graphic display of the echo signal <b>Automatic</b> The transmitter uses the gain value determined in the self-test (initialization). In the measuring mode, this value is automatically adapted to the current process conditions. <b>Manual</b> You can enter a fixed gain value for diagnostics or test purposes.
 Common gain values for applications involving relatively clear water and a "hard" separation zone are between 25 and 35. The values can be as high as 60 if the sludge/water transition is relatively "soft". If you require significantly higher gain values, this is an indication of overranging. It is then difficult or impossible to reliably evaluate the echo signal.		
Current gain	0 to 100 <b>Factory setting</b> 30	You can only configure the value for manual acoustic control. The value is read-only for automatic acoustic control.
Gain control set point <i>Acoustic control="Automatic"</i>	1 to 50 <b>Factory setting</b> 20	Horizontal position of the intersection of the separation zone line with the echo peak. The factory setting "20" corresponds to 20 % of the maximum display height.
Refresh rate	<ul style="list-style-type: none"> <li>■ 2 s</li> <li>■ 4 s</li> <li>■ 6 s</li> <li>■ 8 s</li> </ul> <b>Factory setting</b> 4 s	Time frame for data refresh
Damping	5 to 255 <b>Factory setting</b> 130	Number of averaged values until data refresh Select a low damping value if the height of the separation zone can change very quickly. Higher damping prevents the system from tracking echo signals that occur briefly (e.g. caused by material movement, a rake or a floor scraper).



## 18.5 Extended setup

### 18.5.1 Sensor signal

You can adapt the sensor signal to the measuring point in this menu.

**Path: Menu/Setup/Inputs/UIS/Extended setup/Sensor signal**

Function	Options	Info
Sound speed	300 to 2000 m/s (985 to 6561 ft/s) <b>Factory setting</b> 1482 m/s (4862 ft/s)	The sound speed depends on the medium temperature and the medium density. Since the temperature and density only fluctuate slightly in most water and wastewater applications, the factory setting of 1482 m/s proves to be a suitable value.
 Always speak to the manufacturer's service team before changing the setting for Sound speed.		
▶ Sedimentation area		
Gain band	5 to 30 <b>Factory setting</b> 20	Restricts the gain in automatic mode in order to prevent system overload.
Gain increment	0.1 to 0.5 <b>Factory setting</b> 0.1	Defines how quickly the gain can adapt to changing process conditions in the automatic mode.
▶ Bottom definition		
Range above bottom	0.0 to 1.0 m (0.0 to 3.2 ft) <b>Factory setting</b> 0.1 m (0.3 ft)	Zone around the basin floor in which extraneous signals can occur. Signals above your setting are masked out. This is needed for very low sludge levels or basins free from sludge.
Bottom signal set point	0 to 100 <b>Factory setting</b> 60	Restricts the gain in automatic mode in order to prevent system overload when the basin is empty or does not have an interface.

## 18.5.2 Calculation

Path: Menu/Setup/Inputs/UIS/Extended setup/Calculation

Function	Options	Info
Interface	Options <ul style="list-style-type: none"> <li>■ Top layer</li> <li>■ Lower interface</li> </ul> <b>Factory setting</b> Top layer	Defines which signal the system should track and display when several separation zones are calculated.  <b>Top layer</b> Determine the interface of thin material in the upper section  <b>Lower interface</b> Determine the interface of thicker material near the floor
Interface window	Options <ul style="list-style-type: none"> <li>■ Off</li> <li>■ On</li> </ul> <b>Factory setting</b> Off	You can open another window near the separation zone. Specify a distance above and below the separation zone. The system primarily focuses on the signal within this window. Any signal outside this window must meet the search criteria for a separation zone for an extended period before the system recognizes it as a separation zone.
Above interface <i>Interface window="On"</i>	0.0 to 10.0 m (0.0 to 32.8 ft)  <b>Factory setting</b> 0.6 m (2.0 ft)	The interface window is indicated by broken lines in the graphic mode. The window is 1.2 m wide in the factory setting for both parameters.
Below interface <i>Interface window="On"</i>		
Gate response rate	0 to 50  <b>Factory setting</b> 1	The response rate determines the speed at which the system updates the measuring window. A high value stands for a quick change.
Threshold	0 to 100  <b>Factory setting</b> 0	Filter for examining signals If a high value is selected, stronger signals are taken into account more. If a low value is selected, weaker signals are taken into account more.

## 18.5.3 Diagnostics settings

This menu branch is used for specifying warning limits, and for defining whether and how diagnostics tools should be used.

The associated diagnostics code is displayed for every setting.

### Alarm delay echo loss

Path: Menu/Setup/Inputs/UIS/Extended setup/Diagnostics settings

Function	Options	Info
Alarm delay echo loss	0 to 255 min  <b>Factory setting</b> 10 min	Delay time for an error message if the echo is lost

## **Diagnostic behavior**

→ "Inputs: General/Frequently occurring functions" section →  98

### **18.5.4 Restart the sensor signal**

The sensor is reinitialized with the "Restart sensor signal" action.

The sensor starts in the automatic mode and searches for the separation zone with the last sensor settings. The first measured value appears after around 3 to 5 minutes.

### **18.5.5 Sensor replacement**

→ "Inputs: General/Frequently occurring functions" section →  98

### **18.5.6 Data processing factory setting**

→ "Inputs: General/Frequently occurring functions" section →  98

### **18.5.7 Sensor factory setting**

→ "Inputs: General/Frequently occurring functions" section →  98

---

## Index

### A

Activation code	23
Additional functions	
Cleaning programs	87
Limit switch	84
Mathematical functions	88
Alarm relay	
Cleaning	82
Diagnostics message	81
Limit switch	81
Automatic hold	8

### B

Basic program	35
Basic settings	6
Chlorine	133
Conductivity	113
Interface measurement	166
ISE	156
Nitrate	151
Oxygen	123
pH/ORP	104
SAC	146
Turbidity	141
Binary inputs	24
Binary outputs	75
Bottle synchronization	35
Bus address	19

### C

Calibration settings	
Chlorine	135
ISE	161
Nitrate	152
Oxygen	126
pH/ORP	106
SAC	147
Turbidity	142
Calibration timer	99, 162
Calibrations	
Cap, chlorine	138

### Cap

Calibrations	130
Chlorine calibrations	138
Sterilizations	130
Cap calibrations	130
Cap sterilizations	130
Cell constant	113
Chloride compensation	159
Chlorine	
Basic settings	133
Calibration settings	135
Diagnostics settings	136
Extended setup	134
Main value	133
Medium compensation	135
Unit	134
Cleaning	99
Cleaning programs	87
Conductivity	
Diagnostics settings	119
Extended setup	119
Format	116
Temperature format	119
Unit	116
Current inputs	28

### D

Damping	98, 156
Data administration	
Firmware update	21
Loading the setup	22
Saving the setup	22
Data management	
Activation code	23
Exporting the setup	22
Data processing	103
Date and time	7
Delta slope	
Chlorine	137
ISE	164
Oxygen	128
pH	111

Delta zero point	
Chlorine	138
ISE	164
Oxygen	129
pH	112
Diagnostics settings	18
Chlorine	136
Chlorine slope	136
Conductivity	119
Delta slope chlorine	137
Delta slope ISE	164
Delta slope oxygen	128
Delta slope pH	111
Delta zero point chlorine	138
Delta zero point ISE	164
Delta zero point oxygen	129
Delta zero point pH	112
Diagnostic behavior	101
Interface	170
ISE	163
Nitrate	153
Operating hours conductivity	119
Operating hours ISE	165
Operating hours oxygen	131
Operating hours pH/ORP	110
Operating hours, chlorine	139
Operating hours, nitrate	153
Operating hours, SAC	148
Operating hours, turbidity	143
Oxygen	127
pH/ORP	107
Polarization detection	121
Process check system	119
SAC	148
Sensor check system	107
Sensor condition check	109–110
Slope ISE	163
Slope oxygen	128
Slope pH	108
Turbidity	143
Zero point chlorine	137
Zero point ISE	163
Zero point Oxygen	129
Zero point pH	109

## E

Electrode slot	158
Electrolyte counter	140
EP	121
Event program	69
Extended setup	
Chlorine	134
Conductivity	119
Data management	21
Diagnostics settings	18
HART bus address	19
Interface	169
ISE	157, 159
Nitrate	152
Oxygen	124
pH/ORP	105
SAC	147
Turbidity	142

## F

Factory setting	
Data processing	103
Sensor	103
Firmware update	
Controller	21
Flow-paced program	42

## G

General settings	
Automatic hold	8
Basic settings	6
Date and time	7
Extended setup	18
Logbooks	8

## I

Inputs	
Chlorine	133
Conductivity	113
General	98
Interface	166
ISE	156
Nitrate	151
Oxygen	123
pH/ORP	104
SAC	146
Turbidity and solids	141
Installation factor	114

Interface	
Alarm delay	170
Calculation	170
Diagnostics settings	170
Extended setup	169
Sensor signal	168–169
Signal restart	171
Tank configuration	167
Interface measurement	
Basic settings	166
ISE	
Basic settings	156
Calibration settings	161
Compensation K and Cl	159
Diagnostics settings	163
Electrode slot	158
Extended setup	157, 159
Main value	156
Standard addition	162
<b>L</b>	
Limit switch	81, 84
Limit value-controlled program	71
Logbooks	8
<b>M</b>	
Main value	
Chlorine	133
ISE	156
Oxygen	123
Manual hold	99
Mathematical functions	
Degassed conductivity	90
Difference	89
Dual conductivity	91
pH calculation	92
Redundancy	89
rH value	90
Measured value formats	
Nitrate	152
SAC	147
Turbidity	142
Medium compensation	
Chlorine	135
Oxygen	125, 127
pH	105

## N

Nitrate	
Basic settings	151
Calibration settings	152
Diagnostics settings	153
Extended setup	152
Formats	152
Stability criteria	153

## O

Operating hours	
Chlorine	139
Conductivity	119
ISE	165
Nitrate	153
Oxygen	131
pH/ORP	110
SAC	148
Turbidity	143
Operating mode	113
Outputs	
Alarm relays	80
Binary outputs	75
Current outputs	78
Oxygen	
Basic settings	123
Calibration settings	126
Diagnostics settings	127
Extended setup	124
Main value	123
Temperature compensation	124
Unit	124

---

## P

pH/ORP	
Basic settings	104
Calibration settings	106
Diagnostics settings	107
Extended setup	105
Tag control	103
Pharmaceutical water	121
Polarization detection	121
Potassium compensation	159
Process check system	100, 119
Program switchover	56
Program type	
Advanced	59
Basic	35
Flow-paced	42
Standard	50
Time/flow-paced	46
Time-paced	37
Program types	32

## R

Relay	
Cleaning	82
Diagnostics message	81
Limit switch	81

## S

SAC	
Basic settings	146
Calibration settings	147
Diagnostics settings	148
Extended setup	147
Formats	147
Stability criteria	148
Sampling methods	32
Sensor check system	107
Sensor condition check	109–110
Sensor factory setting	103
Sensor identification	104, 113, 123, 133, 141, 146, 151, 156
Sensor replacement	103
Sensor signal	168–169
Setup	
Export	22
Load	22
Save	22

Slope	
Chlorine	136
ISE	163
Oxygen	128
pH	108
Stability criteria	
Chlorine	136, 161
Nitrate	153
Oxygen	126
pH/ORP	106
SAC	148
Turbidity	143
Standard addition	162
Sterilizations	102

## T

Tag control	103
Tank configuration	167
Temperature compensation	116
Oxygen	124
Temperature format	119
Time/flow-paced program	46
Time-paced program	37
Turbidity	
Basic settings	141
Calibration settings	142
Diagnostics settings	143
Extended setup	142
Formats	142
Stability criteria	143

## U

Unit	
Chlorine	134
Oxygen	124
USP	121

## Z

Zero point	
Chlorine	137
ISE	163
Oxygen	129
pH	109

[www.addresses.endress.com](http://www.addresses.endress.com)

---

**Endress+Hauser**   
People for Process Automation

---

BA00464C/07/EN/16.12  
71185371  
FM9







