



Level



Pressure



Flow



Temperature



Liquid
Analysis



Registration



Systems
Components



Services



Solutions

Safety Instructions

Cerabar M

PMC51, PMP51, PMP55

4-20 mA HART

Ex ia IIC T6...T4 Ga/Gb

INMETRO IEE 11.0075



XA01035P-A

Safety instructions for electrical apparatus for explosion-hazardous areas according to ABNT NBR IEC 60079-0

Cerabar M

PMC51, PMP51, PMP55

4-20 mA HART

Associated Documentation

This document is an integral part of the following Operating Instructions:
BA00382P/00

The Operating Instructions which are supplied and correspond to the device type apply.

Supplementary Documentation

Explosion-protection brochure:
CP021Z/00

Designation

Explanation of the labelling and type of protection can be found in the explosion protection brochure.

**Designation of type of protection/
level of protection**

Ex ia IIC T6...T4 Ga/Gb

Applied standards

ABNT NBR IEC 60079-0 :2008
ABNT NBR IEC 60079-11 :2009
ABNT NBR IEC 60079-26 :2008

**Safety instructions:
Installation**

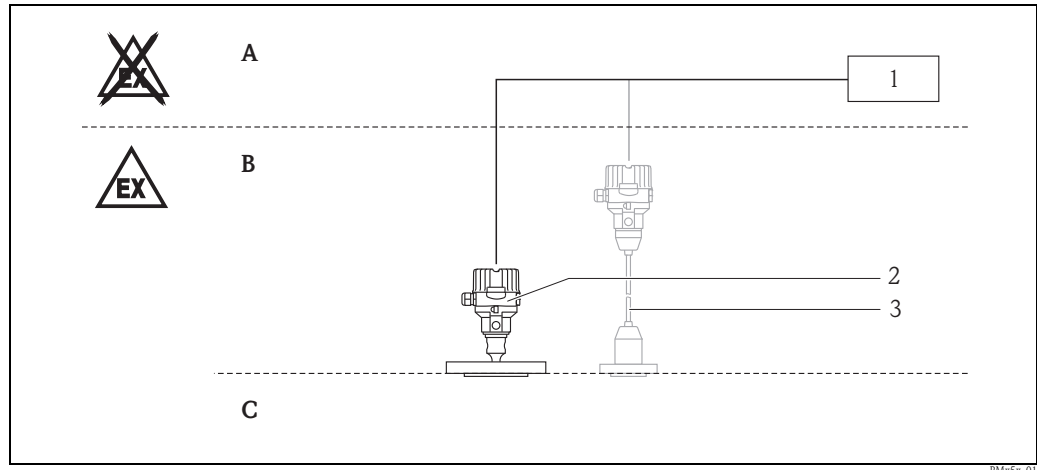

 1

- A** Power supply
B Zone 1, Electronic
C Zone 0, Process

- 1 Certified associated apparatus
 2 PMC51, PMP51 or PMP55
 3 Option: Separate housing

- Comply with the installation and safety instructions in the Operating Instructions.
- Install the device according to the manufacturer's instructions and any other valid standards and regulations.
- Only install the devices in media for which the wetted materials have sufficient durability.
- Execute inspection and maintenance of equipment according to requirements of ABNT NBR IEC 60079-17.
- Execute repair, overhaul and recovery of equipment according to requirements of ABNT NBR IEC 60079-19.
- Staff must meet the following conditions for mounting, electrical installation, commissioning and maintenance of the device:
 - Be suitably qualified for their role and the tasks they perform
 - Be trained in explosion protection
 - Be familiar with national regulations (e.g. ABNT NBR IEC 60079-14)
- Avoid electrostatic charging of the plastic surfaces, for plastic process connections or plastic coatings.
- When the device is connected to an intrinsically safe circuit Ex ib, the level of protection changes to Ex ib. Do not operate intrinsically safe circuits Ex ib in zone 0.
 When the device is connected to an intrinsically safe circuit Ex ic, the level of protection changes to Ex ic. Do not operate intrinsically safe circuits Ex ic in zone 0 or zone 1.
- The intrinsically safe input power circuit of the device is isolated from ground potential and has a dielectric strength of at least 500 V_{rms} with respect to it.
- After aligning (rotating) the housing, retighten the fixing screw.
- Avoid impact or friction sparks for light metal flanges or flange faces (e.g. titanium, zirconium).
- In case of additional or alternative special varnishing of the enclosure or other metallic parts the danger of an electrostatic charging must be observed. Do not rub surfaces with dry cloth.

**Safety instructions:
Zone 0**

- Only operate devices in potentially explosive vapour/air mixtures under atmospheric conditions:
 - 20 °C ≤ T ≤ +60 °C
 - 0.8 bar ≤ p ≤ 1.1 bar
- If no potentially explosive mixtures are present, or if additional protective measures have been taken, the transmitters may be operated under other atmospheric conditions in accordance with the manufacturer's specifications.
- Associated apparatus with galvanic isolation between the intrinsically safe and non-intrinsically safe circuits are preferred.

For PMC51, the following also applies:

- On installations requiring overvoltage protection to comply with national regulations or standards (e.g. ABNT NBR IEC 60079-14), this device shall be installed using an overvoltage protector (e.g. HAW560Z and HAW562Z from Endress+Hauser).

Temperature tables

Type of protection/ level of protection	Temperature class	Process temperature	Ambient temperature (Housing)
Ex ia IIC T6...T4 Ga/Gb	T6	$\leq 80\text{ °C}$	$-40\text{ °C} \leq T_a \leq +40\text{ °C}$
	T4	$\leq 125\text{ °C}$	$-40\text{ °C} \leq T_a \leq +70\text{ °C}$

The process temperatures refer to the temperature at the separation membrane of PMC51 and PMP51. For PMP55 higher temperatures are permitted depending on the type of diaphragm seal (do not exceed the max. ambient temperature at the housing).

Connection data

Electrical Data
$U_i \leq 30\text{ V DC}$ $I_i \leq 300\text{ mA}$ $P_i \leq 1\text{ W}$ $C_i \leq 10\text{ nF}$ $L_i = 0$

www.endress.com/worldwide

Endress + Hauser 
People for Process Automation

XA01035P-A/00/EN/01.12
71190987
CCS/FM 9.0

