

Safety Instructions

**Cerabar S**

**PMP71, PMP75**

**4-20 mA HART, PROFIBUS PA, FOUNDATION Fieldbus**

Ex d IIC T6 Gb

IECE<sub>x</sub> KEM 10.0031

**XA00510P-B**

Safety instructions for electrical apparatus for explosion-hazardous areas according to IEC standards



# Cerabar S PMP71, PMP75

## 4-20 mA HART, PROFIBUS PA, FOUNDATION Fieldbus

**Associated Documentation**

This document is an integral part of the following Operating Instructions:  
 HART: BA00271P/00, BA00274P/00  
 PROFIBUS PA: BA00295P/00, BA00296P/00  
 FOUNDATION Fieldbus: BA00302P/00, BA00303P/00  
 The Operating Instructions which are supplied and correspond to the device type apply.

**Supplementary Documentation**

Explosion-protection brochure:  
 CP021Z/00

**Designation**

Explanation of the labelling and type of protection can be found in the explosion protection brochure.

---

<b>Designation according to IECEx Equipment protection level (EPL)</b>	<b>Gb</b>
<b>Designation of type of protection</b>	<b>Ex d IIC T6 Gb Ex d IIC T4/T2 Gb</b>

**Applied standards**

**IEC60079-0: 2011  
 IEC60079-1: 2007**

**Safety instructions:  
Installation**

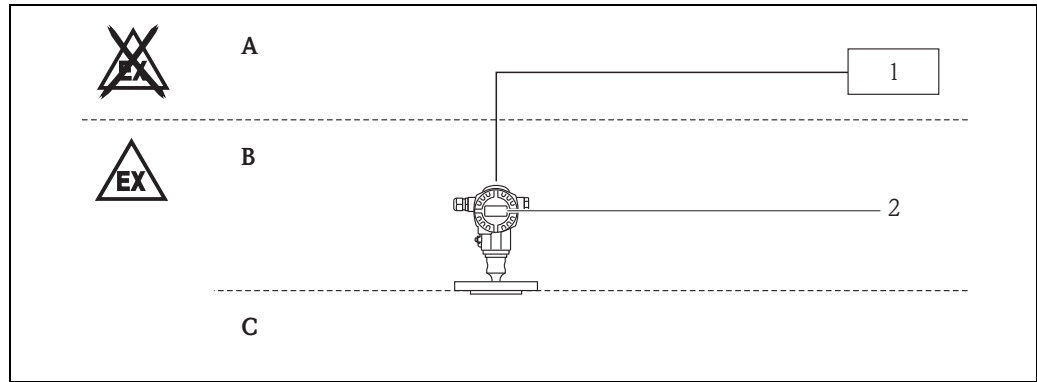

1

- A** Power supply  
**B** Zone 1, Electronic  
**C** Zone 1, Process
- 1 Power supply  
 2 PMP71, PMP75

- Comply with the installation and safety instructions in the Operating Instructions.
- Install the device according to the manufacturer's instructions and any other valid standards and regulations .
- Only install the devices in media for which the wetted materials have sufficient durability.
- Do not open the connection or electronics compartments under voltage in an explosive atmosphere.
- During operation, the cover must be screwed all the way in and the cover's safety catch must be fastened.
- Connect the device using suitable cable and wire entries or using piping systems of protection type "Pressure-tight Enclosure d".
- For connection through a conduit entry approved for this purpose the associated sealing facility shall be mounted directly to the housing.
- For ambient temperatures higher than +70 °C, use suitable heat-resisting cables or wires.
- Avoid electrostatic charging of the plastic surfaces, for plastic process connections or plastic coatings.
- Avoid impact or friction sparks for light metal flanges or flange faces (e.g. titanium, zirconium).
- After aligning (rotating) the housing, retighten the fixing screw.
- In case of additional or alternative special varnishing of the enclosure or other metallic parts the danger of an electrostatic charging must be observed. Do not rub surfaces with dry cloth.
- Seal unused entry glands with approved sealing plugs that correspond to the type of protection. The plastic transport sealing plug does not meet this requirement and must therefore be replaced during installation.
- Only use certified cable entries or sealing plugs. The metal sealing plugs supplied meet this requirement.
- Only use genuine spare parts from Endress+Hauser which are specified for the device.

**Instructions:  
Ex d joints**

**Specification according to IEC/EN 60079-1:2007, Chapter 5.1**

- If required or if in doubt: ask manufacturer for specifications.

**Temperature tables**

Type of protection/ level of protection	Type	Temperature class	Process temperature	Ambient temperature (Housing)
Ex d IIC T6 Gb	PMP71, PMP75	T6	≤ 80 °C	-40 °C ≤ Ta ≤ +75 °C
Ex d IIC T4/T2 Gb	PMP71	T4	≤ 120 °C	

The process temperatures refer to the temperature at the separation membrane of PMP71.  
For PMP75, higher temperatures are permitted depending on the type of diaphragm seal (do not exceed the max. ambient temperature at the housing).

**Connection data**

Electronic insert	Electrical data
4-20 mA HART	U ≤ 45 V DC P ≤ 3 W
PROFIBUS PA, FOUNDATION Fieldbus	U ≤ 32 V DC P ≤ 3 W





[www.endress.com/worldwide](http://www.endress.com/worldwide)

---

**Endress + Hauser**   
People for Process Automation

---

XA00510P-B/00/EN/13.13  
71204525  
CCS/FM 9.0

